

Regelverteiler / Control distributor SH-CD6-230 77420064, SH-CD6-230 77420065, SH-CD6-24 77420076, SH-CD6-24 77420077

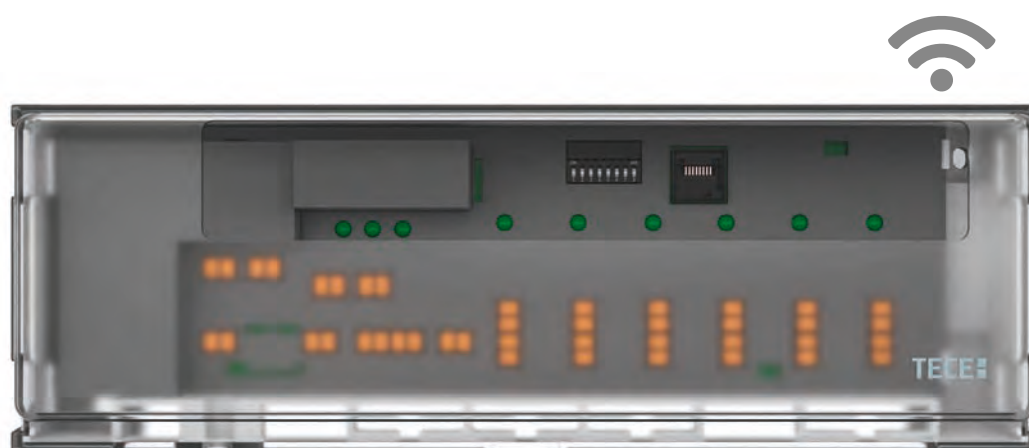

DE	BEDIENUNGSANLEITUNG	3
GB	USER GUIDE	17
FR	GUIDE D'UTILISATION	31
ES	GUIA DE USUARIO	45
IT	GUIDA UTENTE	59
NL	HANDLEIDING	73
NO	BRUKERHANDBOK	87
SE	BRUKSANVISNING	101
HR	PRIRUČNIK ZA RAD	115
RO	GHIDUL UTILIZATORULUI	129

Inhalt

1. Allgemeine Informationen	4
1.1 Sicherheitshinweise und Betriebsanleitung	4
1.2 Anwendung	4
2. Präsentation	4
2.1 Funktionen	4
2.2 Lieferumfang	5
2.3 Erstmalige Installation	5
3. Produktbeschreibung	5
3.1 LED-Farbbedeutungen	5
3.2 Tasten	5
3.3 DIP-Schalter-Konfiguration	6
3.4 USB-Stick	6
4. Eingänge/Ausgänge	7
4.1 Spannungsversorgung	7
4.2 Heizen/Kühlen (H&C) Eingang	7
4.3 Pumpen Ausgang	8
4.4 Kontakt für Temperaturbegrenzung	8
4.5 Eingang Feuchteerkennung	8
4.6 NC/NO-Stellantriebe	9
4.7 Externe Antenne	10
5. Konfiguration des Systems	10
5.1 Systemkonfiguration ohne Zentraleinheit	10
5.2 Systemkonfiguration mit Zentraleinheit	13
5.3 Steuerung eines Luftentfeuchters pro Raum	13
6. Weitere Merkmale	14
6.1 Anti-Grip-Funktion	14
6.2 Zurücksetzen	14
6.3 Fehlersuche	15
7. Technische Merkmale	15
7.1 Technische Daten	15
7.2 Abmessungen und Gewicht	16
8. Richtlinien	16

1. Allgemeine Informationen

1.1 Sicherheitshinweise und Betriebsanleitung

Dieses Produkt sollte vorzugsweise von einem qualifizierten Fachmann installiert werden. Vorbehaltlich der Einhaltung der oben genannten Bedingungen übernimmt der Hersteller die Haftung für das Gerät im Rahmen der gesetzlichen Bestimmungen. Alle Anweisungen in dieser Installations- und Betriebsanleitung sind bei der Arbeit mit dem Regler zu beachten. Fehler, die durch unsachgemäße Installation, unsachgemäßen Gebrauch oder mangelhafte Wartung verursacht werden, führen zum Erlöschen der Herstellerhaftung.



Jeder Reparaturversuch entbindet von der Verantwortung und der Verpflichtung zu Garantie und Ersatz durch den Hersteller. 2012/19/EU (WEEE-Richtlinie): Produkte, die mit diesem Symbol gekennzeichnet sind, dürfen in der Europäischen Union nicht als unsortierter Siedlungsabfall entsorgt werden. Für ein ordnungsgemäßes Recycling geben Sie dieses Produkt beim Kauf eines gleichwertigen Neugeräts an Ihren örtlichen Lieferanten zurück oder entsorgen Sie es an den dafür vorgesehenen Sammelstellen. Für weitere Informationen siehe: www.stiftung-ear.de.

1.2 Anwendung

Der Regler ist für den Einsatz in Wohnräumen, Büroräumen und Industrieanlagen konzipiert. Vergewissern Sie sich vor der Inbetriebnahme, dass die Installation den geltenden Vorschriften entspricht, um eine ordnungsgemäße Nutzung der Anlage zu gewährleisten.

2. Präsentation

Die Anschlussbox SH-CD ist speziell für die Steuerung Ihrer Flächenheizung und -kühlung konzipiert. Sie ermöglicht den einfachen und schnellen Anschluss von Thermostaten und Stellantrieben. Es sind vier Versionen verfügbar:

	230 V Ausführung	24 V Ausführung
6 Zonen	SH-CD6-230	SH-CD6-24 (Externer 230 V / 24 V Transformator erforderlich: SH-ST)
10 Zonen	SH-CD10-230	SH-CD10-24 (Externer 230V/24 V Transformator erforderlich: SH-ST)

2.1 Funktionen

Es hat mehrere Funktionen integriert:

- Wandmontage oder Halterung auf DIN-Schiene
- Steckbare Kabelverbindungen mit Zugentlastung
- LED-Statusanzeige und DIP-Schalter zur Geräteeinstellung
- Verwaltung von 6 oder 10 Zonen mit 2 Stellantrieben pro Zone
- Einfaches Gruppieren der Zonen auf demselben Thermostat
- Konfiguration mehrerer Systeme
- H&C-Eingang (230 V und spannungsfreies Signal)
- Messung der Wassertemperatur (Fühler nicht im Lieferumfang enthalten) zur Feuchterkennung
- Pumpen- oder Kesselausgang (230 V und spannungsfreies Signal)
- Anti-Grip-Management
- Kontakt für Temperaturbegrenzung
- Interne Funk-Antenne, optionale externe Antenne
- Arbeitet mit NC- und NO-Stellantrieben
- USB-Anschluss für Software-Update und Datenaufzeichnung

2.2 Lieferumfang



2.3 Erstmalige Installation

Es gibt zwei Möglichkeiten, den Regelverteiler zu installieren:

- Wandmontage mit zwei Schrauben
- Montage auf einer Hutschiene 35 x 7,5 (DIN EN 60715)

3. Produktbeschreibung

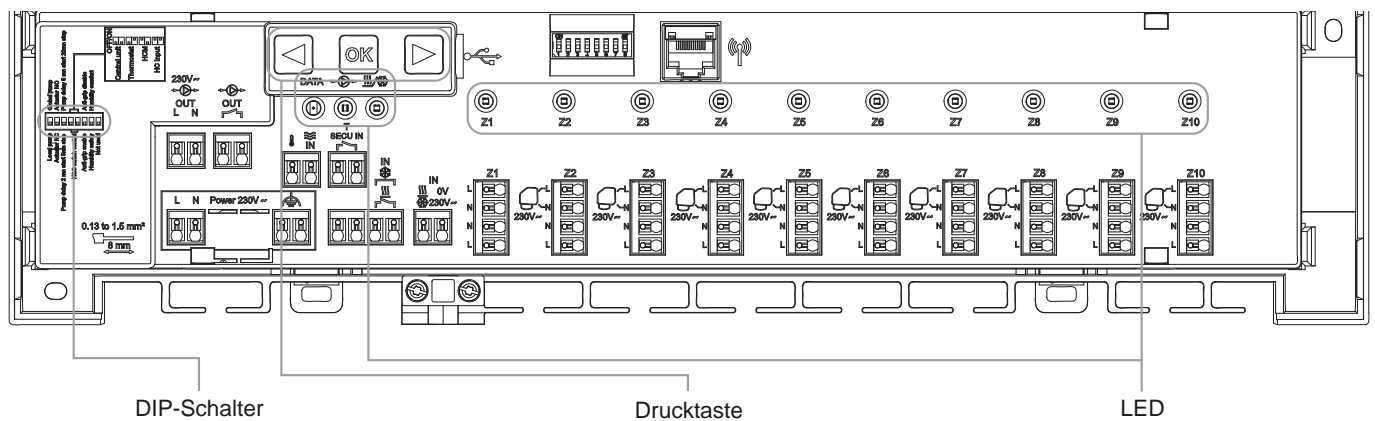

3.1 LED-Farbbedeutungen

LED	Bedeutung
LED Heizen und Kühlen (Rot/Blau)	Fix Rot = Heizbetrieb. Fix Blau = Kühlbetrieb. Rot blinkend (bei Heizung) oder Blau blinkend (bei Kühlung) = Sicherheitserkennung. Rot / blau blinkend = RF-Verlust (mit SH-CD, SH-HCM, SH-CU, interne Antenne). Im Falle eines RF-Verlusts schaltet das System in den Heizbetrieb.
LED Pumpe/Entfeuchter (Grün/Blau/Rot)	Fix Grün = Pumpe wird ausgelöst. Rot blinkend = Systemfehler (Sicherheitserkennung / Fehler Feuchtesensor/...) Blau blinkend = Globale Feuchteerkennung. Blau blinkend = Problem mit der Feuchtekonfiguration.
LED Datalog (Rot/Grün)	Grün blinkend = Laufende Datenaufzeichnung.
LED pro Zone (Rot/Grün)	Grünes Blinken = RF-Übertragung/Empfang. Fix Rot = Heiz- oder Kühlbedarf in der Zone. Rot blinkend = RF-Fehler Verbindung mit dem Thermostat. Rotes Blinken in allen Zonen = RF-Antennenfehler. Im Falle eines RF-Verlusts mit SH-HCM oder SH-CU, schaltet das System in den Heizbetrieb.

3.2 Tasten

Es sind drei kapazitive (berührungssensitive) Tasten verfügbar:



3.3 DIP-Schalter-Konfiguration

DIP-Schalter	Funktion	Wert (Standard: OFF)		Konfiguration	Beschreibung
DIP1	Einschaltanforderung Pumpe	OFF		Lokal (Anforderung an dieser Klemmleiste)	Siehe 4.3
		ON		Global (Anforderung von anderem Gerät im System)	
DIP2	Stellantrieb Type	OFF		NC-Stellantriebe	Siehe 4.6
		ON		NO-Stellantriebe	
DIP3	Pumpen-Start-Verzögerung (für den ersten angeforderten Antrieb) und Antrieb-Stopp-Verzögerung (für den letzten angeforderten Antrieb)	OFF		2 min / 5 min	Siehe 4.3 und 4.6
		ON		5 min / 20 min	
DIP4 / DIP5	Umschaltsignal Heizen/ Kühlen, Anforderung durch:	OFF	OFF	Zentraleinheit SH-CU	Siehe 4.2
		OFF	ON	Main Thermostat SH-DT	
		ON	OFF	Heizen-Kühlen Modul SH-HCM	
		ON	ON	Klemmleiste SH-CD	
DIP6	Anti-Grip (Pumpen und Ventil Festsitzschutz)	OFF		Aktiviert	Siehe 6.1
		ON		Deaktiviert	
DIP7	Feuchtemanagement	OFF		Sicherheits-Ansatz	Siehe 4.5
		ON		Komfort-Ansatz	
DIP8	Feuchtesensor	OFF		Potenzialfreier Kontakt	Siehe 4.5
		ON		NTC-Sensor	

3.4 USB-Stick

USB-Konnektivität ermöglicht:

- Aktualisieren der Regler Software.
- Aufzeichnung von Daten zur Systemüberwachung (Datalog).

Das Software-Update erhalten Sie auf www.tece.com, speichern Sie die Datei auf einen USB-Stick. Stecken Sie den USB-Stick in den Regler.

- Den Regler AUS / EIN schalten.
- Während der Aktualisierung,
 - Grüne LED schalten ein von Z1 bis Z6/Z10
 - Alle LED werden rot
 - Rote LED schalten aus von Z6/Z10 bis Z1
- Nach der Aktualisierung können Sie den USB-Stick entfernen.

Für die Fehlersuche ist Datalog nützlich. Dabei werden die Daten in einer ASCII-Datei auf dem USB-Stick gespeichert. Durch Drücken von für 5 Sekunden geht der Regler in das Menü Funktionen. Die LED der ersten Zone blinkt entweder rot (Datalog ist aktiviert) oder grün (Datalog ist deaktiviert).

Sie können den Datenlogger aktivieren oder deaktivieren, indem Sie auf klicken.

Langes Drücken auf ermöglicht das Verlassen des Funktionsmenüs (ansonsten gibt es ein Timeout von 10 s, bevor das Funktionsmenü automatisch verlassen wird).

Alle 14 Tage wird eine Protokolldatei erstellt. In der Datei wird alle 10 Minuten ein Eintrag vorgenommen.

4. Eingänge/Ausgänge

4.1 Spannungsversorgung

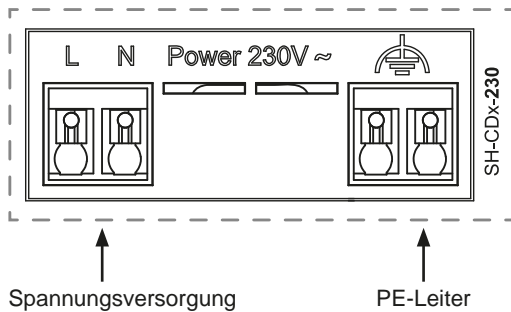

Erfordert die Verwendung eines von TECE gelieferten Transformators (4 Kabel): SH-ST

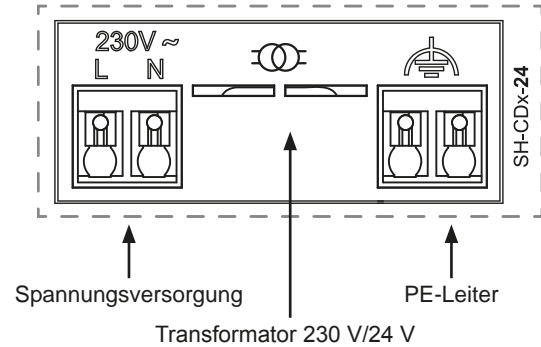

4.2 Heizen/Kühlen (H&C) Eingang

Zweck:

Dieser Eingang ermöglicht die Umschaltung des Systems: Heizen oder Kühlen.

Quelle des Signals:

- Ein manueller Schalter
- Eine Wärmepumpe
- Ein SH-SM, welcher mit der Zentraleinheit SH-CU als EIN/AUS-Gerät gekoppelt ist. Diese Lösung ermöglicht eine Fernsteuerung des Modus Heizen/Kühlen von der App bzw. aus dem Nutzerkonto heraus.

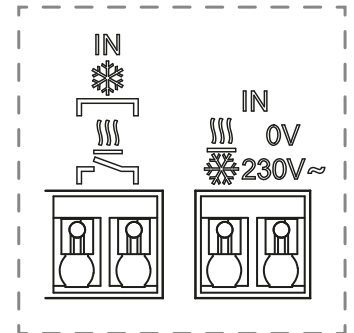

Format des Signals: Der Eingang kann potenzialfrei oder spannungsführend 230 V sein.

Modus	Freier Kontakt	Live-Kontakt
Heizen	Geöffnet	Kein Signal
Kühlen	Geschlossen	230 V AC

Nur ein Gerät im System sollte in der Lage sein, den H&C-Modus zu wählen. Andere mögliche Signalquellen zur Umschaltung Heizen/Kühlen (siehe 3.3):

- Zentraleinheit (manueller H&C-Modus im Menü der Zentrale einstellen), DIP4/DIP5 = OFF/OFF.
- SH-HCM mit integriertem H&C-Eingang, DIP4/DIP5 = ON/OFF.
- Digitaler Thermostat, konfiguriert als Master H&C Thermostat im manuellen oder automatischen Modus (nur ein Thermostat pro Installation), DIP4/DIP5 = OFF/ON.

Wenn mehrere Regelverteiler SH-CD im System vorhanden sind, sollte der H&C-Modus von nur einem Gerät gesteuert werden:

- Ohne Zentraleinheit betrachtet das System den als Main SH-CD festgelegten Regelverteiler (bitte 5.1.2 beachten), DIP4/DIP5 = ON/ON.
- Mit Zentraleinheit:
 - Regelverteiler steuert H&C-Modus, DIP4/DIP5 = DIP4/DIP5 = ON/ON.
 - Zentraleinheit steuert H&C-Modus, DIP4/DIP5 = DIP4/DIP5 = OFF/OFF.

DIP4	DIP5	Umschaltsignal H&C Anforderung durch
OFF	OFF	Zentraleinheit (SH-CU)
OFF	ON	Thermostat
ON	OFF	Heizen-Kühlen Modul (SH-HCM)
ON	ON	Regelverteiler (SH-CD)

4.3 Pumpen Ausgang

Es gibt zwei Ausgänge:

- Ausgang mit stromführendem Kontakt (230 Vac)
- Potenzialfreier Ausgang

Diese Ausgänge können folgende Geräte schalten:

- Ein Zonenventil
- Eine Pumpe
- Einen Heizkessel oder eine Wärmepumpe

Die zwei Ausgänge werden ausgelöst, wenn Heiz- oder Kühlbedarf besteht (siehe 3.3).

- Am Regler, wenn DIP-Schalter 1 = OFF = lokal
- Im System, wenn DIP-Schalter 1 = ON = global

Die Verzögerung zwischen dem Heiz- oder Kühlbedarf und der Aktivierung der Pumpe ist konfigurierbar (siehe 3.3).

- Pumpe startet 2 Minuten nach Heiz- oder Kühlbedarf, wenn DIP-Schalter 3 = OFF
- Pumpe startet 5 Minuten nach Heiz- oder Kühlbedarf, wenn DIP-Schalter 3 = ON

Damit soll die Öffnungszeit des Stellantriebs berücksichtigt werden.

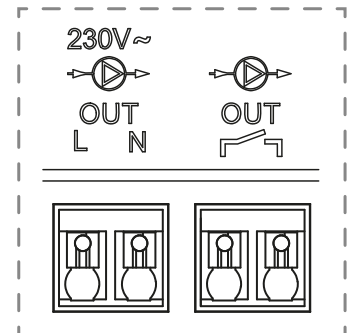

4.4 Kontakt für Temperaturbegrenzung

Dies ist ein Sicherheitseingang (freier Kontakt).

Kontakt geschlossen	Kontakt geöffnet
Keine Sicherheitserkennung	Erkennung von Übertemperatur (Heizen) oder Untertemperatur (Kühlen).

Der Sicherheitseingang sollte verwendet werden, wenn eine Pumpe am Regler angeschlossen ist.

Wenn der Kontakt geöffnet ist,

- wird der Ausgang der lokalen Pumpe gestoppt (auch wenn DIP1 = ON, d.h. globale Pumpe am Regler gewählt ist),
- werden die Antriebe geschlossen,
- blinkt die Pumpe/Trockner-LED rot,
- blinkt die Heiz- und Kühl-LED rot (im Heizbetrieb) oder blau (im Kühlbetrieb)
- und wenn es sich bei dem Regler um einen Sub-Regler handelt, wird der Heiz- oder Kühlbedarf nicht an den Main-Regler gesendet.

Sie können einen Kontaktthermostat für die Temperatursicherheit verwenden.

Sie können zwei Kontaktthermostate in Reihe schalten, um sowohl gegen Übertemperatur als auch gegen Untertemperatur zu schützen (der Sicherheitseingang ist dann sowohl im Heiz- als auch im Kühlbetrieb wirksam).

Das Produkt wird mit einer Kabelbrücke am Anschluss geliefert.

Bitte beachten Sie, dass die Pumpe am SH-HCM ausgelöst wird, wenn an mindestens einem im System installierten SH-CD eine Pumpe ausgelöst wird.

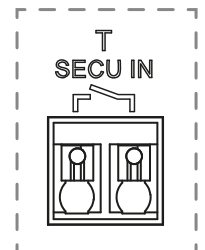

4.5 Eingang Feuchteerkennung

Das Produkt verfügt über einen Eingang zur Feuchteerkennung.

Zwei mögliche Signaltypen gemäß DIP8 (siehe 3.3)

- Ein Feuchtekontaktfühler (Taupunktregler)
- Wassertempersensoren (CTN 10 kΩ): Erfordert SH-DTH Thermostat (Funk-Hygrostat)

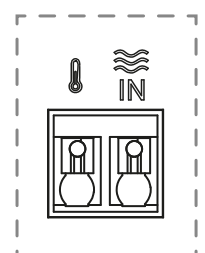

4.5.1 Feuchte Kontaktfühler (Taupunktregler)

DIP8 = OFF

Format des Signals: Der Eingang ist ein freier Kontakt

Keine Luftfeuchtigkeit	Luftfeuchtigkeit erkannt
Kontakt offen	Kontakt geschlossen

Im Kühlbetrieb, wenn Feuchte erkannt wird, wird der Regler

- das Pumpensignal stoppen,
- alle Antriebe der Zonen schließen,
- Feuchtealarm an weitere SH-CD im System senden,
- am SH-HCM den Ausgang Luftentfeuchter aktivieren.

Handelt es sich bei dem Regler um einen Sub-Regler, wird der Kühlbedarf nicht an den Main-Regler gesendet.

4.5.2 NTC-Sensor für die Wassertemperatur

DIP8 = ON

Es gibt zwei Verwendungen für die Wassertemperaturmessung.

Erkennung der Luftfeuchte

Im Kühlbetrieb berechnet der Regler für jede Zone den Taupunkt auf der Grundlage der Umgebungstemperatur und der relativen Luftfeuchte, die von jedem Thermostat gesendet werden (Funk-Hygrostat erforderlich).

Wenn die Wassertemperatur in einer Zone den Taupunkt erreicht, wird der Regler aktiviert:

Sicherheits-Ansatz DIP7 = OFF	Komfort-Ansatz DIP7 = ON
Schließt den Stellantrieb dieser Zone und stoppt die Kühlanforderung darin.	Lässt den Stellantrieb dieser Zone eine Stunde lang geöffnet, schließt dann den Stellantrieb und stoppt die Kühlanforderung in der Zone, wenn der Feuchtealarm weiterhin ausgelöst wird.

- Aktiviert den externen Luftentfeuchter der Zone.
- Fordert den SH-HCM an, den globalen Luftentfeuchter für mindestens 15 Minuten und bis zum Verschwinden des Alarms zu aktivieren, wenn in der Zone kein externer Luftentfeuchter verfügbar ist.

Handelt es sich bei dem Regler um einen Sub-Regler, wird der Kühlbedarf nicht an den Main-Regler gesendet.

Erkennung des Heiz- und Kühlmodus

Wenn DIP4/DIP5 = ON/ON (H&C Umschaltung = SH-CD) und DIP8 = ON wird die Wassertemperatur zur automatischen Erkennung des H&C-Modus verwendet.

- Beträgt die Wassertemperatur > 24 °C, ist das System im Heizbetrieb.
- beträgt die Wassertemperatur < 20 °C, ist das System im Kühlbetrieb.

Diese Funktion ist nützlich, wenn die Wärmepumpe automatisch in den Heiz- oder Kühlmodus schaltet und keinen Ausgang hat, um das System zu informieren.

- Wenn der SH-HCM die Wassertemperatur misst, wird dieser Wert an den SH-CD gesendet und verwendet, wenn dort kein Wassertempersensoren vorhanden ist.
- Wenn der H&C-Eingang = Kühlbetrieb ist, schaltet das System unabhängig von der Wassertemperatur in den Kühlbetrieb.

4.6 NC/NO-Stellantriebe

Anschluss eines NC- oder NO-Stellantriebs pro Anschluss

- 230 V-Antriebe für SH-CD-230
- 24 V-Antriebe für SH-CD-24

Die Stellantrieb Type wird durch DIP2 definiert.

Es ist notwendig, für alle Antriebe denselben Typ zu verwenden. Wenn in einer Zone ein Heiz- oder Kühlbedarf besteht, wird der Stellantrieb sofort aktiviert. Wenn die Heiz- oder Kühlanforderung gestoppt wird, wird der Stellantrieb sofort deaktiviert, es sei denn, es handelt sich um den zuletzt im Regler geöffneten Stellantrieb.

In diesem Fall ist die Verzögerung vor dem Schließen des Stellantriebs abhängig von DIP3 (siehe 3.3)

- wenn DIP3 = OFF, wartet das System 5 Minuten, bevor es den letzten Antrieb schließt
- wenn DIP3 = ON, wartet das System 20 Minuten, bevor es den letzten Antrieb schließt

Begründung: Viele Wärmepumpen haben eine eingebaute Ausschaltverzögerung (um ein aufeinanderfolgendes Aus- und Einschalten bzw. Takten zu vermeiden). Dabei läuft die Wärmepumpe x Minuten über den eigentlichen Ausschaltzeitpunkt weiter. Es ist wichtig, dass mindestens ein Kreislauf offenbleibt, es sei denn, es gibt einen Pufferspeicher, eine hydraulische Weiche oder einen Bypass in der Anlage.

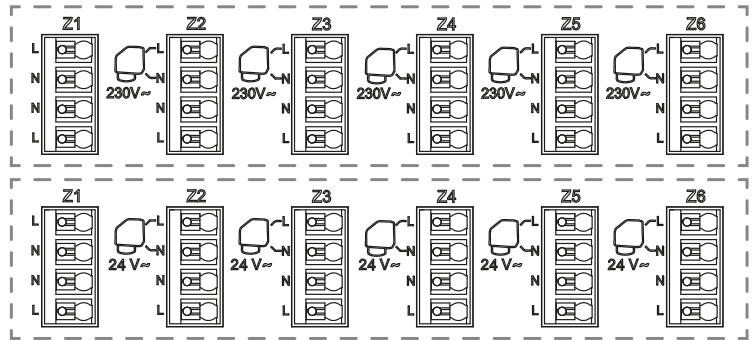

4.7 Externe Antenne

Im Regler ist eine interne Antenne eingebaut. Falls erforderlich, kann eine externe Antenne angeschlossen werden, um die RF-Kommunikation zu verbessern. Dies kann sinnvoll sein, wenn der Regler in einem Metallgehäuse installiert ist. In diesem Fall müssen Sie die externe Antenne außerhalb des Metallgehäuses installieren.

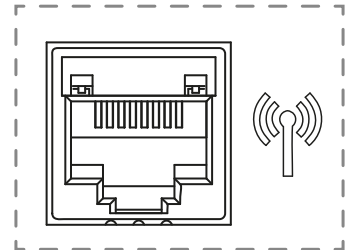

Bitte beachten Sie die Hinweise zur Montage, um die Reichweite zu optimieren und Funktionsstörungen zu vermeiden.

Die Antenne muss wie folgt installiert werden:

- außerhalb des Metallgehäuses
- in vertikaler Position und mindestens 50 cm von Metallteilen entfernt

Wenn Sie mehrere Antennen (mehrere Regler) haben, müssen diese in einem Abstand von mindestens 80 cm zueinander angebracht werden.

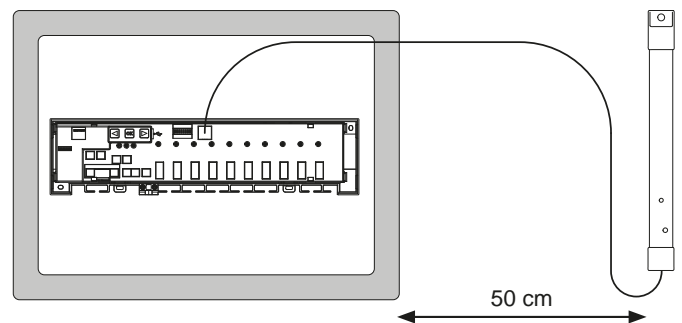





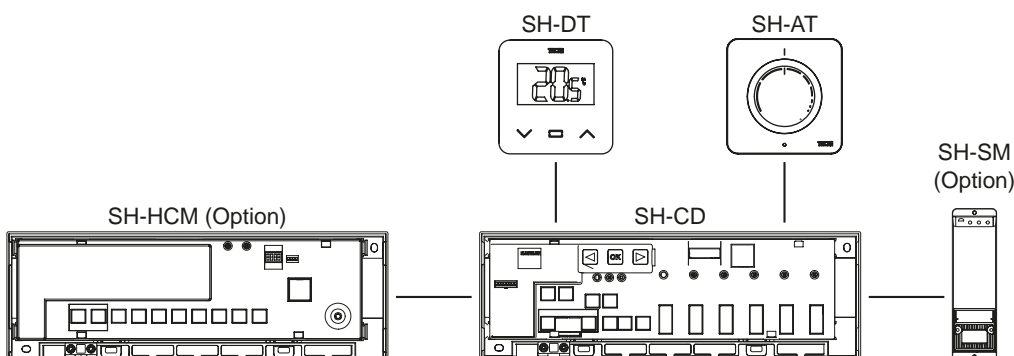

5. Konfiguration des Systems

5.1 Systemkonfiguration ohne Zentraleinheit

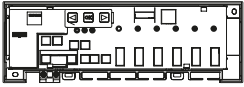
5.1.1 Eigenständige Installation

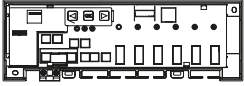
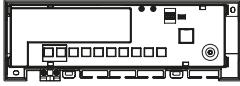
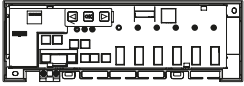
Nur ein Regler oder mehrere Regler ohne Zusammenschaltung

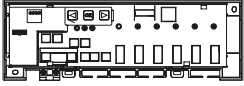

Gerät 1	Gerät 2	Bemerkungen
 <p>Durch Drücken von OK für 5 Sekunden, wechselt der Regler in den RF-Kopplungsmodus. Wählen Sie mit ◀ oder ▶ die Zone 1 (LED blinkt rot) und drücken Sie OK um in den Modus „Kopplung mit Thermostat“ zu gelangen. Hinweis: Eine grün blinkende LED ist eine Positionsanzeige. Bewegen Sie die grün blinkende LED mit ◀ oder ▶ um die zu koppelnde(n) Zone(n) auszuwählen. Wählen Sie die Zone mit OK aus bzw. heben Sie damit die Auswahl auf. Die gewählte Zone ist dauerhaft rot, blinkt aber weiterhin zusätzlich grün (Positionsanzeige). Eine bereits gekoppelte Zone ist dauerhaft grün.</p>	 <p>Thermostate: Versetzen Sie das Gerät in den RF-Kopplungsmodus (siehe Bedienungsanleitung des jeweiligen Gerätes).</p>	<p>Wenn die Funkkopplung erfolgt ist, erlöschen die LEDs der auf dem SH-CD ausgewählten Zonen und die Thermostate verlassen den Kopplungsmodus. Um ein anderes Thermostat zu koppeln, müssen Sie den Modus erneut aufrufen/starten. Verlassen des Kopplungsmodus: Drücken Sie lange auf ◀.</p>
 <p>Durch Drücken von OK für 5 Sekunden, wechselt der Regler in den RF-Kopplungsmodus. Wählen Sie mit ◀ oder ▶ die Zone 3 (LED blinkt rot) und drücken Sie OK um in den Modus „Kopplung mit Zusatzgerät“ zu gelangen. Alle LEDs blinken grün.</p>	 <p>Versetzen Sie SH-HCM in den RF-Kopplungsmodus. Drücken Sie dazu die Taste für 10 Sekunden. Weitere Hinweise entnehmen Sie der Anleitung des Gerätes.</p>	<p>Wenn die Verbindung hergestellt ist, kehrt der SH-CD in das Menü für die RF-Kopplung zurück, und der SH-HCM kehrt in den normalen Modus zurück. Verlassen des RF-Kopplungsmodus: Drücken Sie lange auf ◀. HINWEIS: nur ein Heizen-Kühlen Modul SH-HCM pro Anlage.</p>
 <p>Durch Drücken von OK für 5 Sekunden, wechselt der Regler in den RF-Kopplungsmodus. Wählen Sie mit ◀ oder ▶ die Zone 3 (LED blinkt rot) und drücken Sie OK um in den Modus „Kopplung mit Zusatzgerät“ zu gelangen. Alle LEDs blinken grün.</p>	 <p>Versetzen Sie SH-SM in den RF-Kopplungsmodus. Drücken Sie dazu die Taste für 5 Sekunden. Weitere Hinweise entnehmen Sie der Anleitung des Gerätes.</p>	<p>Wenn die Verbindung hergestellt ist, beendet SH-SM den Kopplungsmodus. SH-CD kehrt dagegen in den Kopplungsmodus zurück. Verlassen des RF-Kopplungsmodus: Drücken Sie lange auf ◀.</p>
 <p>Durch Drücken von OK für 5 Sekunden, wechselt der Regler in den RF-Kopplungsmodus. Wählen Sie mit ◀ oder ▶ die Zone 3 (LED blinkt rot) und drücken Sie OK um in den Modus „Kopplung mit Zusatzgerät“ zu gelangen. Alle LEDs blinken grün.</p>	 <p>Versetzen Sie SH-R in den RF-Kopplungsmodus. Drücken Sie dazu die Taste für 3 Sekunden. Weitere Hinweise entnehmen Sie der Anleitung des Gerätes.</p>	<p>Wenn die Verbindung hergestellt ist, beendet SH-R den Kopplungsmodus. Die LED leuchtet dauerhaft grün. SH-CD kehrt dagegen in den Kopplungsmodus zurück. Verlassen des RF-Kopplungsmodus: Drücken Sie lange auf ◀.</p>

5.1.2 Installation von mehreren Reglern

Bei mehreren miteinander verbundenen Reglern in der Anlage gibt es einen Hauptregler (Main SH-CD) und bis zu drei Nebenregler (Sub SH-CD).

Der Hauptregler zentralisiert die Informationen für die Nebenregler. Wenn ein Heizen-Kühlen Modul SH-HCM verwendet wird, sollte es mit dem Hauptregler gekoppelt werden.

- Der Hauptregler gibt den Heiz- und Kühlmodus an die Nebenregler weiter. Diese Information kann vom SH-HCM oder von einem Master-Digital-Thermostat kommen, je nach DIP4 und DIP5 (siehe 3.3)
- Der Hauptregler kann das Pumpensignal der gesamten Anlage gemäß DIP1 verarbeiten (siehe 3.3)

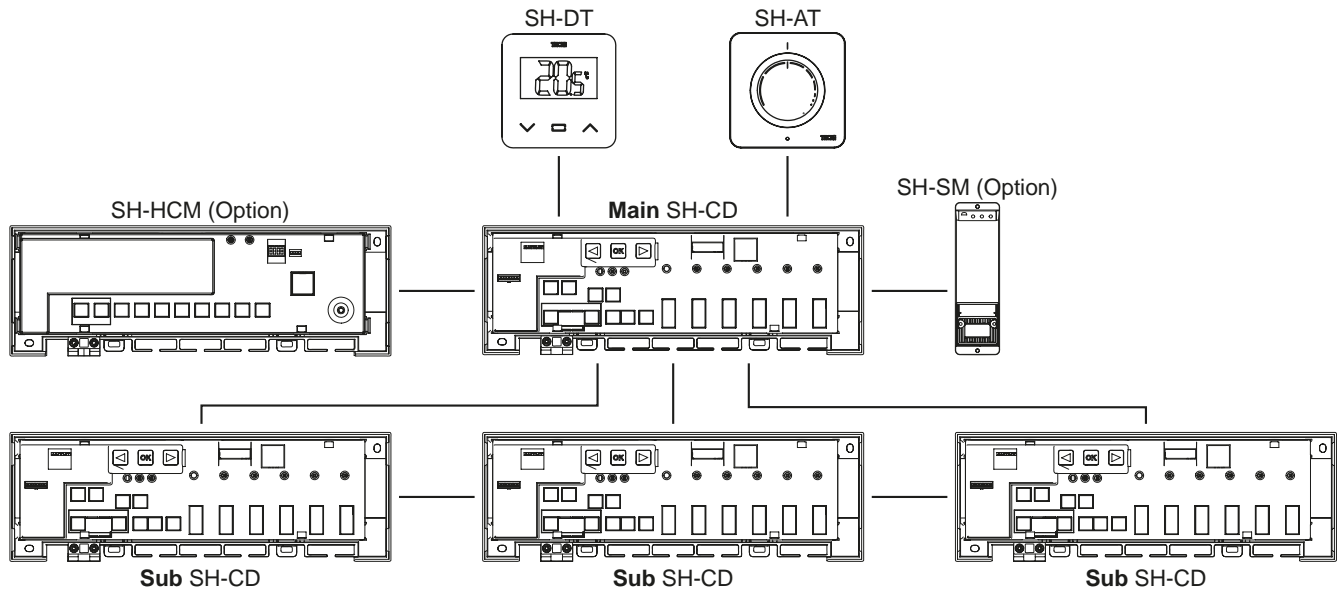

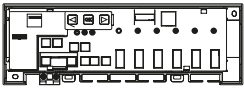
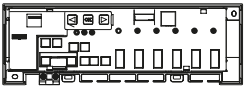
Gerät 1: Hauptregler (Main)	Gerät 2: Nebenregler (Sub)	Bemerkungen
Zunächst sind alle Funk-Thermostate mit den jeweiligen Funk-Regelverteilern SH-CD zu paaren! Siehe 5.1.1		
 <p>Durch Drücken von OK für 5 Sekunden, wechselt der Regler in den RF-Kopplungsmodus. Wählen Sie mit ◀ oder ▶ die Zone 3 (LED blinkt rot) und drücken Sie OK um in den Modus „Kopplung mit Zusatzgerät“ zu gelangen. Alle LEDs blinken grün.</p>	 <p>Durch Drücken von OK für 5 Sekunden, wechselt der Regler in den RF-Kopplungsmodus. Wählen Sie mit ◀ oder ▶ die Zone 2 (LED blinkt rot) und drücken Sie OK um in den Modus „Kopplung mit Hauptregler“ zu gelangen. Alle LEDs blinken rot.</p>	<p>Wenn die Verbindung hergestellt ist, kehren beide SH-CD in den Kopplungsmodus zurück. Verlassen des RF-Kopplungsmenüs: Drücken Sie lange auf ◀.</p>

5.2 Systemkonfiguration mit Zentraleinheit

Die Zentraleinheit zentralisiert die Kommunikation zwischen den Reglern.

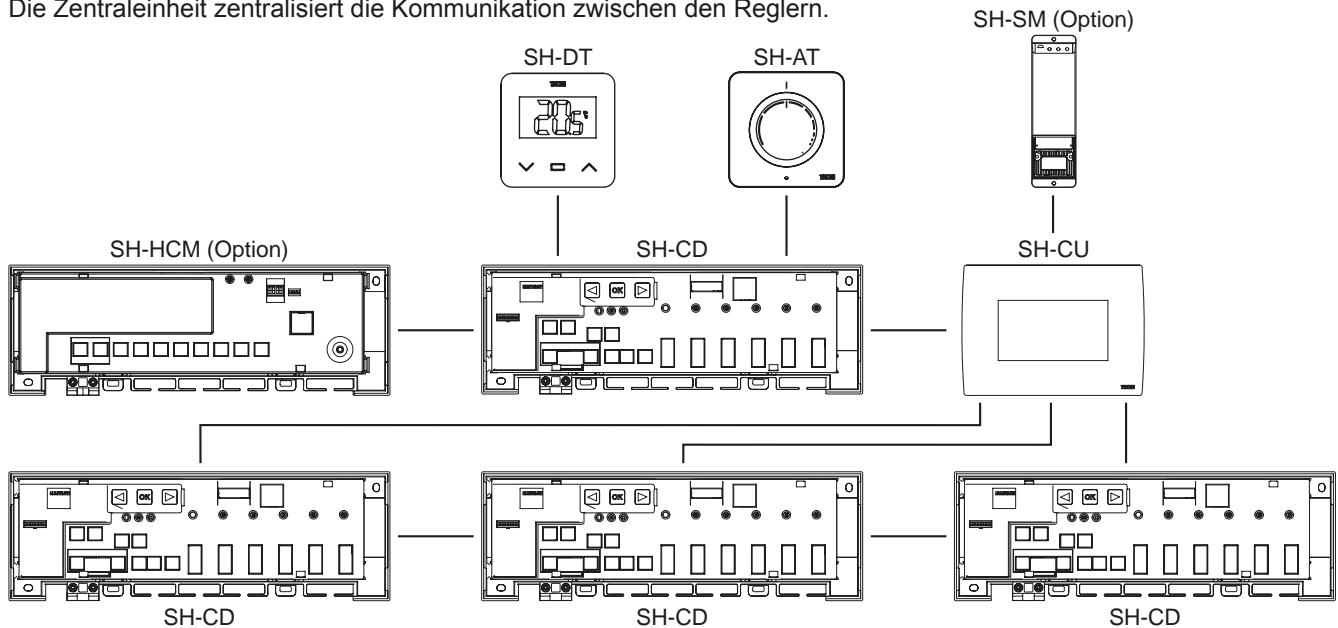

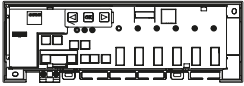
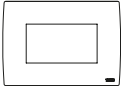
Gerät 1: SH-CD	Gerät 2: SH-CU	Bemerkungen
Zunächst sind alle Funk-Thermostate mit den jeweiligen Funk-Regelverteilern SH-CD zu paaren! Siehe 5.1.1		
 <p>Durch Drücken von OK für 5 Sekunden, wechselt der Regler in den RF-Kopplungsmodus. Wählen Sie mit ◀ oder ▶ die Zone 2 (LED blinkt rot) und drücken Sie OK um in den Modus „Kopplung mit Hauptregler“ zu gelangen. Alle LEDs blinken rot.</p>	 <p>Versetzen Sie das Gerät in den RF-Kopplungsmodus. Wählen Sie einen Raum (Raum 1). Beim Koppeln eines SH-CD mit SH-CU wird für jeden Funk-Thermostat ein Raum generiert. Die Räume dürfen deshalb nicht vorher in der Zentraleinheit angelegt werden.</p>	<p>Wenn die Verbindung hergestellt ist, verlassen sowohl SH-CD als auch SH-CU den Kopplungsmodus. Verlassen des RF-Kopplungsmodus: Drücken Sie lange auf ◀.</p>

5.3 Steuerung eines Luftentfeuchters pro Raum

Es gibt zwei Möglichkeiten, Feuchtigkeit zu erkennen:

- Auf der Ebene des Reglers mit Hilfe des Eingangs Feuchteerkennung (siehe 4.5).
- Auf Raumebene, wenn der Thermostat einen Sensor für die relative Luftfeuchte enthält (Funk-Hygrostat).

Wenn Feuchtigkeit erkannt wird, gibt es zwei Möglichkeiten, den Entfeuchter zu aktivieren:

- Ein globaler Luftentfeuchter wird durch den SH-HCM ausgelöst, wenn die Funktion auf dem SH-HCM aktiviert ist.
- Ein Luftentfeuchter wird auf der Ebene des Raumes ausgelöst, in dem die Feuchtigkeit festgestellt wird. In diesem Fall müssen Sie an jeder Zone des Reglers einen SH-SM-Empfänger koppeln, um einen Luftentfeuchter auszulösen.

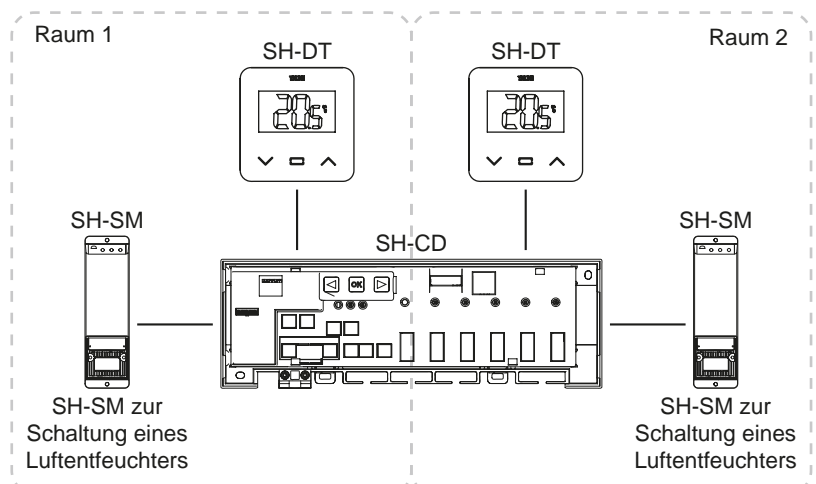

Gerät 1: SH-CD	Gerät 2: SH-SM	Bemerkungen
<p>Durch Drücken von für 5 Sekunden, wechselt der Regler in den RF-Kopplungsmodus. Wählen Sie mit oder die Zone 4 (LED blinkt rot) und drücken Sie um in den Modus „Kopplung mit Entfeuchter“ zu gelangen. Wählen Sie die Zonen mit oder . Zonen werden durch gepaarte Thermostate definiert.</p> <p>Beispiel: TH1 = Z1, TH2 = Z2+Z3 und TH3 = Z4+Z5+Z6. Die Navigation schlägt 3 Zonen vor, um einen Entfeuchter mit (Z1), (Z2+Z3) und (Z4+Z5+Z6) zu koppeln.</p> <p>Wählen Sie die Zone mit aus/ab. (Sie können nur eine Zone pro Entfeuchter auswählen). Der Cursor blinkt grün. Die ausgewählte Zone blinkt rot und grün Die bereits gepaarte Zone ist dauerhaft grün.</p> <p>(Um einen Luftentfeuchter zu entfernen, wählen Sie eine Zone mit grüner LED aus, drücken Sie dann gleichzeitig auf und , um die Zone grün blinken zu lassen).</p>	 <p>Versetzen Sie SH-SM in den RF-Kopplungsmodus. Drücken Sie dazu die Taste für 5 Sekunden. Weitere Hinweise entnehmen Sie der Anleitung des Gerätes.</p>	<p>Wenn die Verbindung hergestellt ist, beendet SH-SM den Kopplungsmodus. SH-CD kehrt dagegen in den Kopplungsmodus zurück.</p> <p>Verlassen des RF-Kopplungsmodus: Drücken Sie lange auf .</p>

6. Weitere Merkmale

6.1 Anti-Grip-Funktion

Die Funktion wird über DIP6 aktiviert (siehe 3.3). Wenn die Ventile während einer Woche nicht aktiv sind, wird eine komplette Übung ausgelöst (Stellantrieb + Pumpen Ausgänge + Heizen/Kühlen Anforderung, welche an den SH-HCM gesendet wird).

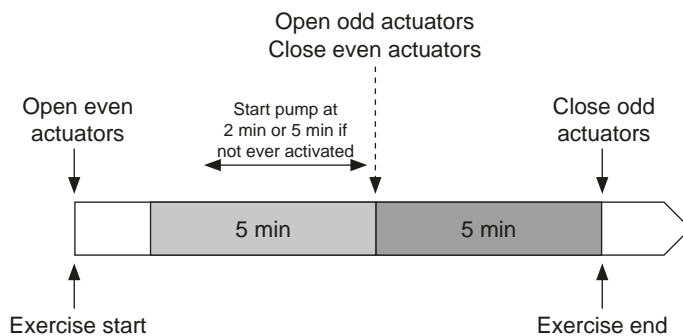

6.2 Zurücksetzen

Im Falle einer Störung kann es erforderlich sein, das Produkt auf die Werkseinstellungen zurückzusetzen.

Durch 5 Sekunden langes Drücken von wechselt der Regler in das Reset-Menü. Die LED der Zone1 blinkt rot und die LEDs der übrigen Zonen blinken grün.

Durch gleichzeitiges Drücken der Tasten , , und bis alle Zonen-LEDs rot leuchten, wird der Regler-Reset ausgelöst und das Produkt startet neu. Die LEDs erlöschen.

6.3 Fehlersuche

Symptom	Problem	Beschreibung	Fehlerbehebung
Rotes oder blaues Blinken der Heiz- und Kühl-LEDs und Rotes Blinken der Pumpe/ Trockner LED.	Erkennung der Sicherheit.	Der Kontakt des Sicherheitseingangs ist aktiviert.	Wenn Sie kein Sicherheitsthermostat verwenden, vergewissern Sie sich, dass Sie eine Brücke am Eingang Temperatur Sicherheit angebracht haben. Andernfalls kontrollieren Sie die Temperatur des Rohrs (zu heiß im Heizmodus, zu kalt im Kühlmodus).
Rotes/blauges Blinken der Heiz- und Kühl-LED.	RF-Problem.	Der Regler hat die Verbindung mit einem anderen RF-Gerät als einem Thermostat verloren.	Prüfen Sie den Abstand zwischen den Geräten. Wenn der Regler in einem Metallgehäuse installiert ist, verwenden Sie eine externe Antenne, die sich außerhalb des Metallgehäuses befindet. Ein RF-Repeater kann erforderlich sein.
Schnelles blaues Blinken der Pumpe/ Entfeuchter-LED.	Problem bei der Konfiguration der Luftfeuchtigkeit.	NTC-Messung am H&C-Eingang bei DIP8 = OFF. ON/OFF-Eingang am H&C-Eingang, während der DIP8 = ON.	NTC-Temperaturfühler und DIP-Schaltereinstellung prüfen.
Rot blinkend auf 1 Zone.	RF-Fehler mit dem Thermostat.	Der Regler hat die Verbindung mit dem Raumfühler verloren.	Prüfen Sie den Abstand zwischen dem Regler und dem Thermostaten. Ein RF-Repeater kann erforderlich sein.
Rotes Blinken auf allen Zonen.	RF-Antennenfehler.	Der Regler hat alle RF-Verbindungen verloren (Thermostat und andere Geräte).	Eventuell ist eine externe Antenne erforderlich.

7. Technische Merkmale

7.1 Technische Daten

	SH-CD6-24, SH-CD6-230, SH-CD10-24, SH-CD10-230
Elektrischer Schutz	Klasse II mit Schutzleiter
IP-Schutz	IP30
Versand- und Lagertemperatur	-10 °C bis 50 °C (14 °F bis 122 °F)
Spannungsversorgung	230 V AC ± 10 % 50 Hz
Maximale Ausgangslast (2 Ausgänge)	Relais: 5 A
Stellantriebe	230 V/24 V NC/NO bis zu 2 W
Kompatibilität	SH-AT, SH-DT, SH-DTP, SH-HCM, SH-CU, SH-SM

7.2 Abmessungen und Gewicht

SH-CD6-24 und SH-CD6-230:

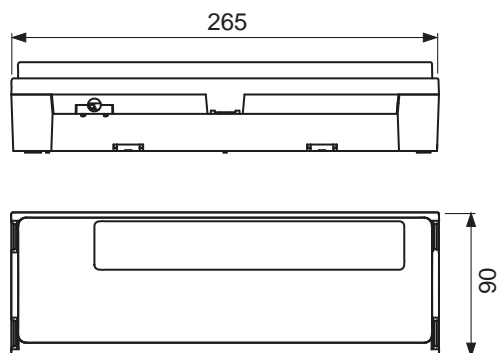

SH-CD10-24 und SH-CD10-v230:

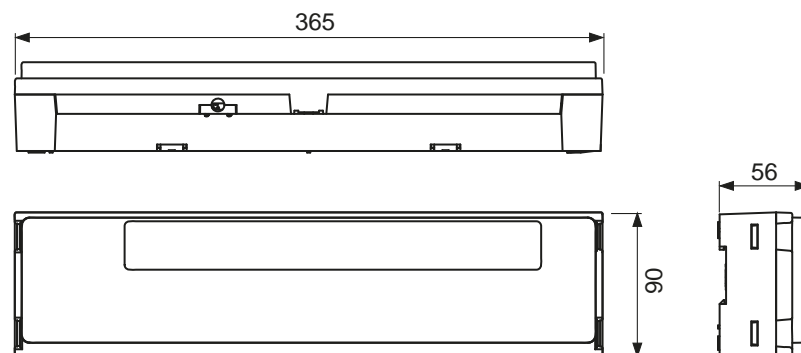

Gewicht: 840 g - SH-CD6
940 g - SH-CD10

8. Richtlinien

Bezeichnung	Beschreibung	Link
Niederspannungsrichtlinie (LVD)	Die Niederspannungsrichtlinie (2014/35/EU) stellt sicher, dass elektrische Betriebsmittel innerhalb bestimmter Spannungsgrenzen ein hohes Schutzniveau für die europäischen Bürgerinnen und Bürger bieten und die Vorteile des Binnenmarktes voll ausschöpfen.	2014/35/UE
Elektromagnetische Verträglichkeit (EMV) Richtlinie 2014/30/EU	Die Richtlinie 2014/30/EU über die elektromagnetische Verträglichkeit (EMV) stellt sicher, dass elektrische und elektronische Geräte keine elektromagnetischen Störungen erzeugen bzw. von diesen nicht beeinträchtigt werden.	2014/30/UE
Beschränkung der Verwendung bestimmter Richtlinie über gefährliche Stoffe (RoHS) 2011/65/ EU	Richtlinie zur Beschränkung der Verwendung bestimmter gefährliche Stoffe in elektrischen und elektronischen Geräten Ausrüstung.	2011/65/EU
Abfall Elektrisch & Elektronische Ausrüstung Richtlinie (WEEE)	Die WEEE-Richtlinie (2012/19/EU) zielt darauf ab, die Menge an Elektro- und Elektronik-Altgeräten zu reduzieren, die auf Deponien landen.	2012/19/EU
Kommission für Ökodesign Verordnung	Ökodesign-Anforderungen für lokale Raumheizgeräte.	2015/1188
Funkanlagenrichtlinie (RED) 2014/53/EU	Die Funkanlagenrichtlinie 2014/53/EU (RED) legt einen Rechtsrahmen für das Inverkehrbringen von Funkanlagen fest.	2014/53/EU

User guide

1. General information	18
1.1 Safety warnings and operating instructions	18
1.2 Application	18
2. Presentation	18
2.1 Functions	18
2.2 Box content	19
2.3 First installation	19
3. Product description	19
3.1 LED color meanings	19
3.2 Keys	19
3.3 DIP switch configuration	20
3.4 Usb stick	20
4. Inputs/outputs	21
4.1 Power supply	21
4.2 Heating/cooling (H&C) Input	21
4.3 Pump Output	22
4.4 Contact for temperature limitation	22
4.5 Humidity detection input	22
4.6 NC/NO actuators	23
4.7 External antenna	24
5. System configuration	24
5.1 System configuration without central unit	24
5.2 System configuration with central unit	27
5.3 Control a dehumidifier per room.	27
6. Other Features	28
6.1 Anti Grip Feature	28
6.2 Reset	28
6.3 Trouble shooting	29
7. Technical characteristics	29
7.1 Technical data	29
7.2 Dimensions and weight	30
8. Directives	30

1. General information

1.1 Safety warnings and operating instructions

This product should be installed preferably by a qualified professional. Subject to observation of the above terms, the manufacturer shall assume the liability for the equipment as provided by legal stipulations. All instructions in this Installation & Operation manual should be observed when working with the controller. Failures due to improper installation, improper use or poor maintenance are voiding manufacturer liability.



Any attempt to repair voids the responsibility and the obligation to guarantee and replacement from the manufacturer. 2012/19/EU (WEEE directive): Products marked with this symbol cannot be disposed of as unsorted municipal waste in the European Union. For proper recycling, return this product to your local supplier upon the purchase of equivalent new equipment, or dispose of it at designated collection points. For more information see: www.recyclethis.info

1.2 Application

The controller has been designed for use in residential rooms, office spaces and industrial facilities. Verify that the installation complies with existing regulations before operation to ensure proper use of the installation.

2. Presentation

The Connecting box SH-CD is especially designed to control your Under Floor Heating and Cooling system. It allows easy and quick connection of thermostats and actuators. 4 versions are available:

	230 V Ausführung	24 V Ausführung
6 zones	SH-CD6-230	SH-CD6-24 (Require external 230 V/24 V transformer: TRF03 230/24)
10 zones	SH-CD10-230	SH-CD10-24 (Require external 230 V/24 V transformer: TRF03 230/24)

2.1 Functions

It has integrated multiple functions:

- Wall mounted or mounter on DIN Rail.
- Push-in cable connections with strain relief.
- LED status indication and DIP switch for device setting.
- Manage 6 or 10 zones with 2 actuators per zone.
- Easy merging of the zones on the same thermostat.
- Multiple systems configuration.
- H&C input (230 V and volt free signal).
- Water temperature measurement (Probe not supplied) for humidity detection.
- Pump or boiler output (230 V and volt free signal).
- Anti-Grip management.
- contact for temperature limitation.
- Internal RF antenna, optional external antenna.
- Works with NC and NO actuators.
- USB connectivity for software update and data log.

2.2 Box content



2.3 First installation

There are 2 ways to install the controller:

1. Wall mounted using 2 screws.
2. Mounted on a DIN Rail 35 x 7,5 (DIN EN 60715).

3. Product description

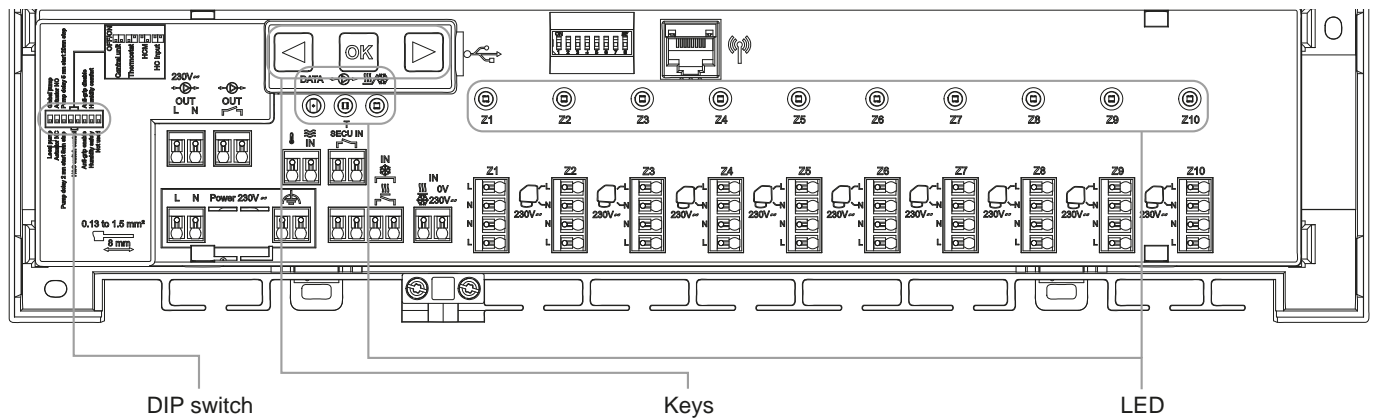

3.1 LED color meanings

LED	Meaning
Heat and Cool LED (Red/Blue)	Fix Red = Heating mode. Fix Blue = Cooling mode. Red blinking (in heating) or blue blinking (in cooling) = Security detection Red / Blue blinking = RF loss (with SH-CD, SH-HCM, SH-CU, internal antenna). In case of RF loss, the system switches in Heating mode.
Pump/Drier LED (Green/Blue/Red)	Fix Green = Pump is triggered. Red blinking = System error (security detection / humidity sensor error/...). Blue blinking = Global humidity detection. Blue flashing = Humidity configuration problem.
Data LED (Red/Green)	Green blinking = Ongoing data log.
LED per zone (Red/Green)	Green blinking = RF transmission/reception. Fix Red = Heating or cooling demand in the zone. Red blinking = RF error with the thermostat. Red blinking on all zones = RF antenna error. In case of RF error with SH-HCM or SH-CU, the system switches in Heating mode.

3.2 Keys

3 capacitive keys are available.



3.3 DIP switch configuration

DIP switch number	Function	Value (default: OFF)		Configuration	Description
DIP1	Controller function	OFF		Local pump	See 4.3
		ON		Global pump	
DIP2	Actuator types	OFF		NC actuator	See 4.6
		ON		NO actuator	
DIP3	Pumpen-Start-Verzögerung (für den ersten angeforderten Antrieb) und Antrieb-Stopp-Verzögerung (für den letzten angeforderten Antrieb)	OFF		2 min/5 min	See 4.3 and 4.6
		ON		5 min/20 min	
DIP4 and DIP5	H&C switch control	OFF	OFF	Central unit SH-CU	See 4.2
		OFF	ON	Master thermostat SH-DT	
		ON	OFF	SH-HCM	
			ON	SH-CD	
DIP6	Anti Grip	OFF		Enabled	See 6.1
		ON		Disabled	
DIP7	Humidity management	OFF		Safety approach	See 4.5
		ON		Comfort approach	
DIP8	Humidity sensor	OFF		ON/OFF sensor	See 4.5
		ON		Water temperature sensor	

3.4 Usb stick

Usb connectivity allows:

- To update the software of the controller.
- To record data for system monitoring (datalog).

For the software update, please refer to www.tece.com for getting the file, put the file on an usb stick.

- Insert the usb stick on the controller.
- Switch off/on the controller.
- During update,
 - Green led are power on from z1 to z6/z10
 - All led become red
 - Red led are power off from z6/z10 to z1
- After update, you can remove the usb stick.

For trouble shooting, datalog is useful to record data on an ascii file stored on the usb dongle for trouble shooting. By pressing for 5 seconds, the master goes in features menu. The led of the first zone blinks either in red (datalog is enable) or in green (datalog is disable). You can enable or disable the datalog by clicking on . Long press on allow to leave the feature menu (otherwise there is a timeout of 10 s before automatically leaving the feature menu)

One log file is created every 14 days. In the file, a record is made every 10 min.

4. Inputs/outputs

4.1 Power supply

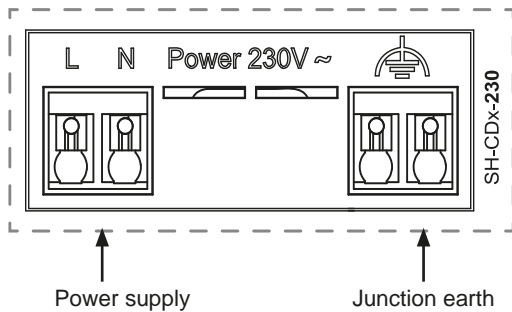

Require using transformer supplied by TECE (4 cables): SH-ST

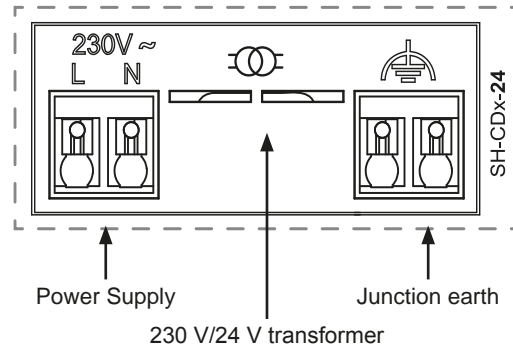

4.2 Heating/cooling (H&C) Input

Purpose: This input allows switching the regulation mode for the system: Heating or cooling.

Source of the signal:

- A mechanical switch
- A Heat Pump
- A SH-SM paired on the SH-CU central unit as an ON/OFF device.
This solution allows getting a remote control of the H&C mode from the application.

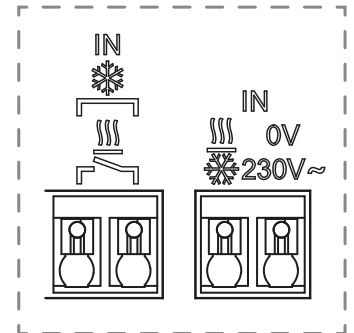

Format des Signals: Der Eingang kann potenzialfrei oder spannungsführend 230 V sein.

Mode	Free contact	Live contact
Heating	Opened	No signal
Cooling	Closed	230 Vac

Only one device in the system should be able to select the H&C mode. Other possible H&C switch signal source (See 3.3)

- Central unit (set manual H&C mode in the installer menu of the central) DIP4/DIP5 = OFF/OFF.
- SH-HCM which embeds a H&C input DIP4/DIP5 = ON/OFF.
- Digital thermostat configured as a Master H&C thermostat in manual or automatic mode (only one thermostat per installation) DIP4/DIP5 = OFF/ON.

If you have multiple connecting boxes SH-CD in the system, the H&C mode should be controlled by only one controller:

- Without central, the system considers the Connecting box set as Main SH-CD (please refer to 5.1.2) DIP4/DIP5 = ON/ON.
- With central:
 - If the Connecting box controls the H&C mode, DIP4/DIP5 = ON/ON.
 - If the Central unit controls the H&C mode, DIP4/DIP5 = OFF/OFF.

DIP4	DIP5	Changeover signal H&C request by
OFF	OFF	Central unit (SH-CU)
OFF	ON	Thermostat
ON	OFF	Heat&cool module (SH-HCM)
ON	ON	Connecting box (SH-CD)

4.3 Pump Output

There are 2 outputs:

- Live contact output (230 Vac)
- Free contact output

These outputs can be used to trigger:

- A zone valve
- A pump
- A boiler or heat pump

The 2 outputs are triggered when there are a heating or cooling demand:

- In the controller if DIP switch 1 = OFF = local
- In the system if DIP switch 1 = ON = global

See 3.3

The delay between the heating or cooling demand and the pump activation is configurable:

- Pump starts 2 minutes after heating or cooling demand if DIP switch 3 = OFF
- Pump starts 5 minutes after heating or cooling demand if DIP switch 3 = ON

See 3.3

The purpose is to consider the latency of the actuator.

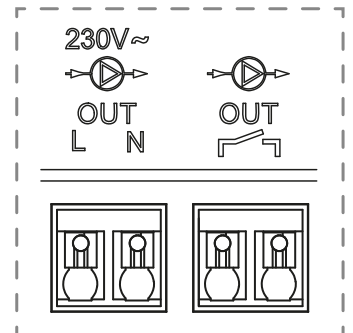

4.4 Contact for temperature limitation

This is a security input (Free contact).

Closed Contact	Opened Contact
No security detection	Overheating or overcooling detection

The security input should be used on a controller with a pump.

When the contact is opened:

- The local pump output is stopped (even if DIP1=ON, i.e. global pump on the controller).
- The actuators are closed.
- The Pump/Drier LED is red blinking.
- The Heat and Cool LED is red blinking (in heating) or blue blinking (in cooling).
- If the controller is a sub controller, the heating or cooling demand is not sent to the main controller.

You can use a contact thermostat for thermal security. You can install 2 contact thermostats in serial to protect against both overheating and overcooling (The security input is valid in both heating and cooling mode).

The product is delivered with a strap on the connector.

Please note that the pump of the SH-HCM is triggered when at least one pump of the multiple SH-CD installed in the system is triggered.

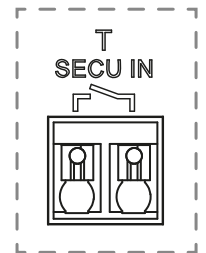

4.5 Humidity detection input

The product has a humidity detection input.

2 possible types of signal according to DIP8 (See 3.3):

- A humidity contact sensor.
- Water temperature sensor (CTN 10 kΩ): Require SH-DTH thermostat.

4.5.1 Humidity contact sensor (dew-point control)

DIP8 = OFF

Format of the signal: The input is a free contact.

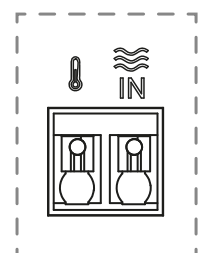

No Humidity	Humidity detected
Opened contact	Closed contact

In cooling mode, when humidity is detected, the controller:

- Stops the pump signal.
- Closes all actuators.
- Sends the humidity alarm to all other SH-CD in the system.
- Requests the SH-HCM to enable the dehumidifier.

If the controller is a sub controller, the cooling demand is not sent to the main controller.

4.5.2 Water temperature sensor

DIP8 = ON

There are 2 usages of the water temperature measurement.

Humidity detection

In cooling mode, for each zone, the controller computes the dew point based on the ambient temperature and relative humidity sent by each thermostat (Thermostat with relative humidity sensor is required).

When the water temperature reaches the dew point in one zone, the controller:

Safety approach DIP7 = OFF	Comfort approach DIP7 = ON
Close the actuator of the zone and stop the cooling demand of the zone.	Keep the actuator of the zone opened for one hour then close the actuator and stop the cooling demand in the zone if the humidity alarm is still triggered.

- Enable remote dehumidifier of the zone.
- Requests the heat&cool module SH-HCM to enable the global dehumidifier for at least 15 min and up the disappearance of the alarm if no remote dehumidifier is available in the zone.

If the controller is a sub controller, the cooling demand of the zone is not sent to the main controller.

Heating&Cooling mode detection

When DIP4 = ON and DIP5 = ON (H&C switch control = SH-CD) and DIP8 = ON the water temperature is used to automatically detect the H&C mode.

- If water temperature > 24°C, the system is in heating mode.
- If water temperature < 20°C, the system is in cooling mode.

This feature is useful when the Heat Pump switches automatically in heating or cooling mode and has no output to inform the system.

- If the SH-HCM measures a water temperature:
- The temperature is sent to the SH-CD which can be used if there is no water temperature sensor.
- If H&C input = cool mode: The system switches in cooling mode regardless the water temperature.

4.6 NC/NO actuators

Connect one NC or NO actuator per connector.

- 230 V actuators for SH-CD-230
- 24 V actuators for SH-CD-24

The type of actuators is defined by DIP2.

It is necessary to use the same type for all actuators.

When there is a heating or cooling demand in one zone, the actuator is triggered immediately.

When the heating or cooling demand is stopped, the actuator is closed immediately except if this is the last actuator opened in the controller. In that case,

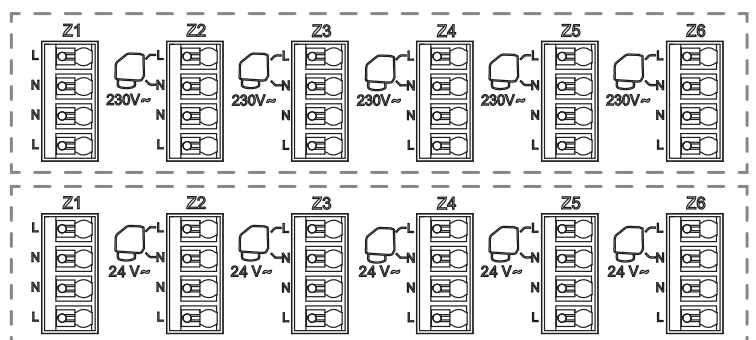

the delay before starting to close the actuator is dependent of DIP3 (See 3.3):

- If DIP3 = OFF, the system waits 5 min before closing the last actuator
- If DIP3 = ON, the system waits 20 min before closing the last actuator

Justification: Many heat pumps have a built-in turn-off delay (to avoid successive switch OFF/ON). In this case, the heat pump continues to run for x minutes beyond the actual switch-off time. It is important to keep at least one circuit open unless there is a buffer tank, hydraulic switch or bypass in the installation.

4.7 External antenna

The controller embeds an internal antenna. If require, an external antenna can be connected to improve the RF communication. It could be useful if the controller is installed inside a metallic box. In that case, you need to install the external antenna outside the metallic box.

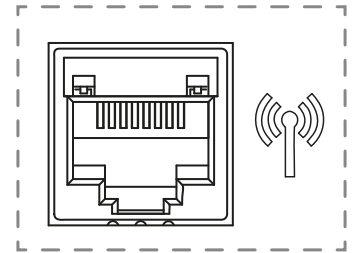

Please respect the mounting to optimize sensitivity and avoid any dysfunction.

Antenna must be installed:

- outside the metallic box
- in vertical position
- and at least at 50 cm of metallic parts.

If you have several antenna (several controllers), they must be placed at minimum 80 cm of each other.

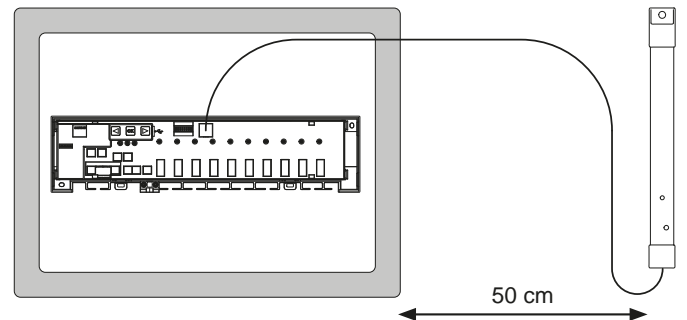



5. System configuration

5.1 System configuration without central unit

5.1.1. Standalone installation

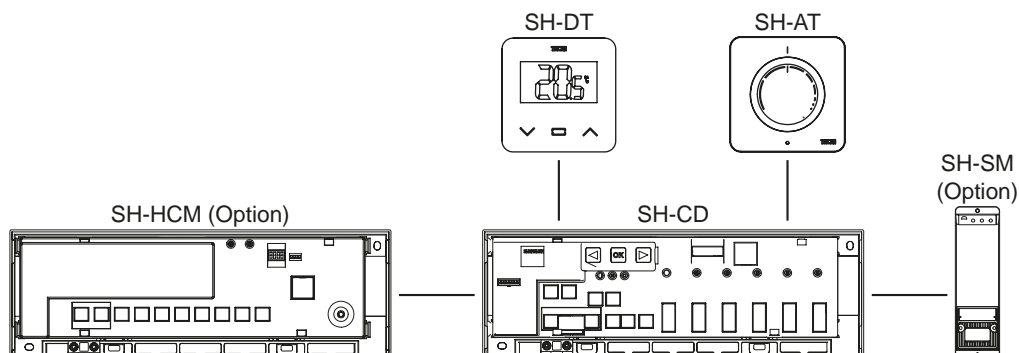
Only one controller or multiple controllers without interconnection.

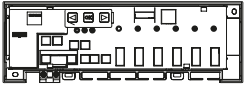
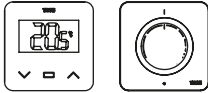
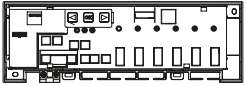
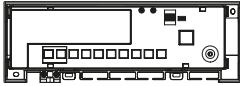
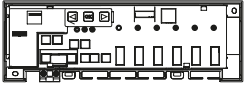

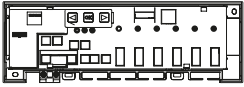
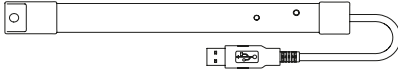
Device 1	Device 2	Remarks
 <p>By pressing OK for 5 seconds, the controller goes in RF pairing mode.</p> <p>By using ◀ or ▶ select zone 1 (LED blinks red), press OK to enter in Pairing with thermostat mode. A green blinking LED is a position indicator.</p> <p>Move the green blinking LED with ◀ or ▶ to select the zone(s) to be paired. Select/deselect the zone with OK. Selected zone is fix red but keeps blinking green (position indicator).</p> <p>Already paired zone is fix green.</p>	 <p>Thermostats: Set product in RF pairing mode (refer to corresponding instruction manual).</p>	<p>If RF pairing is done, the LEDs of the zones selected on the SH-CD must turn off and the thermostats must exit the pairing mode.</p> <p>To pair another thermostat, you need to enter/start the mode again.</p> <p>Exit of the controller coupling mode: Long press on ◀.</p>
 <p>By pressing OK for 5 seconds, the controller goes in RF pairing menu.</p> <p>By using ◀ or ▶ select zone 3 (LED blinks red), press OK to enter in Pairing with a slave device mode.</p> <p>All LEDs are blinking green.</p>	 <p>Set the device to RF coupling mode. Press the button for 10 seconds.</p> <p>For further information, refer to the manual of the respective device.</p>	<p>When link is done SH-CD returns to coupling mode and SH-HCM returns to normal mode.</p> <p>Exit of the controller coupling mode: Long press on ◀.</p> <p>REMARK: only one heat-cool module SH-HCM per installation.</p>
 <p>By pressing OK for 5 seconds, the controller goes in RF pairing menu.</p> <p>By using ◀ or ▶ select zone 3 (LED blinks red), press OK to enter in Pairing with a slave device mode.</p> <p>All LEDs are blinking green.</p>	 <p>Set the SH-SM to RF coupling mode. Press the button for 5 seconds</p> <p>For further information, refer to the manual of the device.</p>	<p>When link is done SH-SM exits coupling mode.</p> <p>SH-CD returns to coupling mode.</p> <p>Exit of the controller coupling mode: Long press on ◀.</p>
 <p>By pressing OK for 5 seconds, the controller goes in RF pairing menu.</p> <p>By using ◀ or ▶ select zone 3 (LED blinks red), press OK to enter in Pairing with a slave device mode.</p> <p>All LEDs are blinking green.</p>	 <p>Set the SH-R to RF coupling mode. Press the button for 3 seconds.</p> <p>For further information, refer to the manual of the device.</p>	<p>When link is done SH-R exits coupling mode.</p> <p>SH-CD returns to coupling mode.</p> <p>Exit of the controller coupling mode: Long press on ◀.</p>

5.1.2. Multiple controller's installation

If there are multiple interconnected controllers in the installation, there are 1 main-controller (Main SH-CD) and up to 3 sub-controllers (Sub SH-CD).

The main controller centralizes the information for the sub-controllers. If a heat-cool module SH-HCM is used, it should be paired to the main-controller.

- The main controller propagates the Heat and Cool mode to the sub-controllers. This information could come from the SH-HCM or from a Master Digital thermostat according to the DIP4 and DIP5 (See 3.3)
- The main controller could handle the pump signal of the whole installation according to DIP1 (See 3.3)

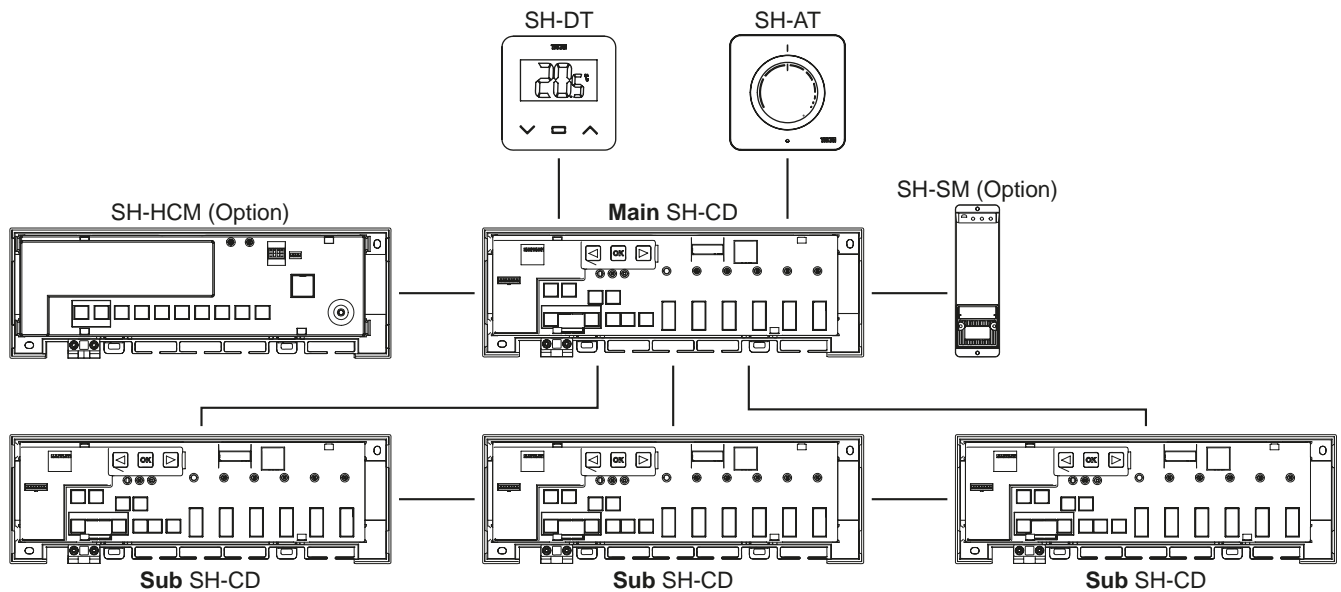

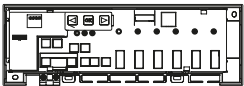
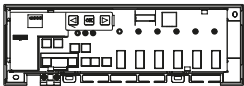
Device 1: Main Controller	Device 2: Sub Controller	Remarks
First, all radio thermostats must be paired with the respective SH-CD controller! See 5.1.1		
 <p>By pressing OK for 5 seconds, the controller goes in RF pairing menu. By using ◀ or ▶ select zone 3 (LED blinks red), press OK to enter in Pairing with a slave device mode. All LEDs are blinking green.</p>	 <p>By pressing OK for 5 seconds, the controller goes in RF pairing menu. By using ◀ or ▶ select zone 2 (LED blinks red), press OK to enter in Pairing with a master device mode. All LEDs are blinking red.</p>	<p>When RF pairing is done, both SH-CD return to pairing mode. Exit of the controller pairing menu: Long press on ◀.</p>

5.2 System configuration with central unit

The central unit centralizes the communication between controllers.

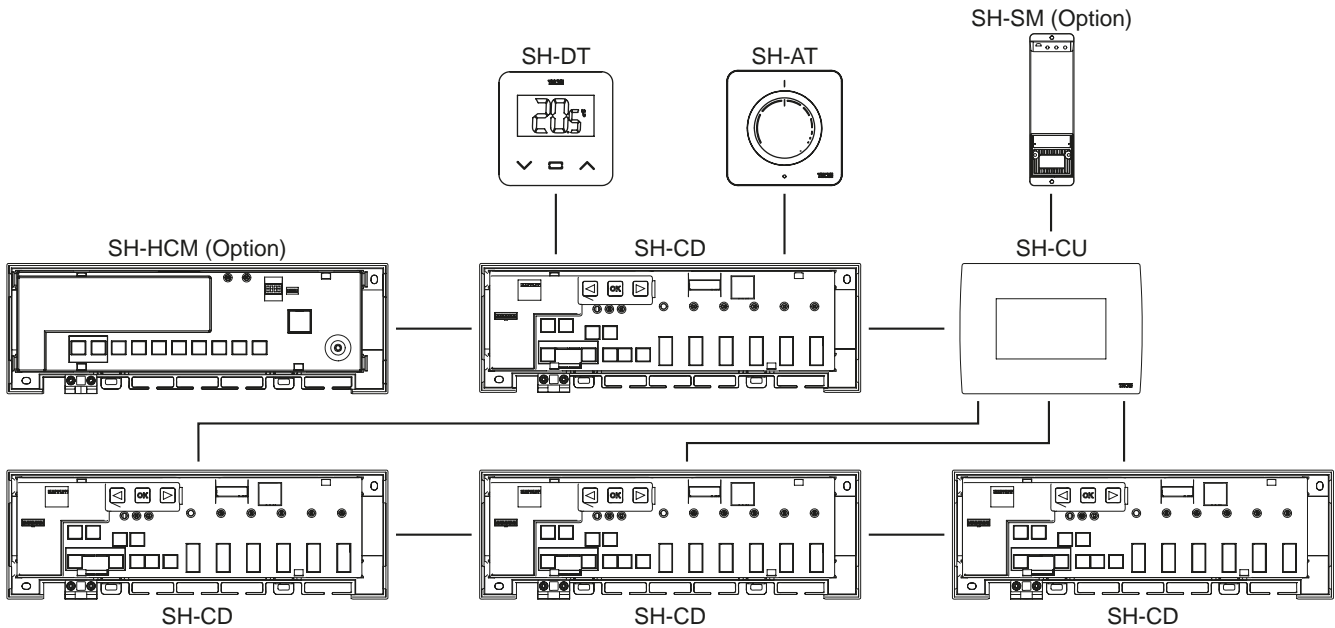

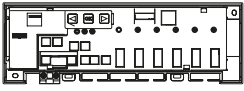
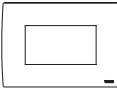
Device 1: SH-CD	Device 2: SH-CU	Remarks
First, all radio thermostats must be paired with the respective SH-CD controller! See 5.1.1		
 <p>By pressing OK for 5 seconds, the controller goes in RF pairing menu. By using ◀ or ▶ select zone 2 (LED blinks red), press OK to enter in Pairing with a master device mode. All LEDs are blinking red.</p>	 <p>Put the device into RF pairing mode. Select a room (Room 1). When pairing a SH-CD with SH-CUF, a room is generated for each wireless thermostat. Therefore, the rooms must not be created in the central unit beforehand.</p>	<p>When RF pairing is done, both SH-CD and SH-CU exit the pairing mode. Exit of the controller pairing menu: Long press on ◀.</p>

5.3 Control a dehumidifier per room.

There are 2 ways to detect humidity:

- At controller level using the humidity detection input (See 4.5).
- At the room level if the thermostat embeds a relative humidity sensor.

When humidity is detected, there are 2 ways to trigger dehumidifier:

- A global dehumidifier is triggered by the SH-HCM if the feature is activated on SH-HCM.
- A dehumidifier is triggered on the room level where the humidity is detected.

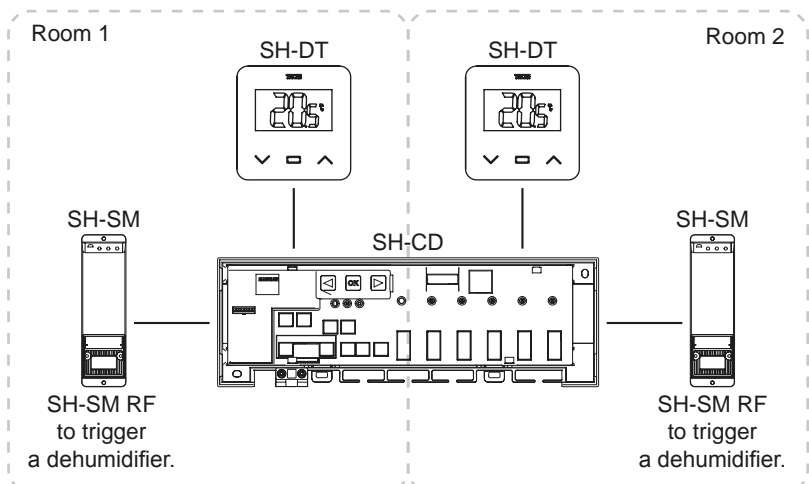

For that case, you need to pair a SH-SM receiver on each zone of the controller to trigger a dehumidifier.

Device 1: SH-CD	Device 2: SH-SM	Remarks
<p>By pressing OK for 5 seconds, the controller goes in RF pairing menu.</p> <p>By using ◀ or ▶ select zone 4 (LED blinks red), press OK to enter in dehumidifier Pairing mode.</p> <p>Choose the zones with ◀ or ▶.</p> <p>Zones are defined by paired thermostat channels.</p> <p>For example: TH1 = Z1, TH2 = Z2+Z3 and TH3 = Z4+Z5+Z6. Navigation proposes 3 zones to pair a dehumidifier on (Z1), (Z2+Z3) and (Z4+Z5+Z6).</p> <p>Select/deselect the zone with OK. (You can select only one zone per dehumidifier). Cursor blinks green.</p> <p>Selected zone is blinking red and green</p> <p>Already paired zone is fix green.</p> <p>(To remove a dehumidifier, select a zone in green, then press simultaneously on ◀ and ▶ up to get the zone blinking in green)</p>	 <p>Set the SH-SM to RF coupling mode.</p> <p>Press the button for 5 seconds.</p> <p>For further information, refer to the manual of the device.</p>	<p>When link is done SH-SM exits coupling mode.</p> <p>SH-CD returns to coupling mode.</p> <p>Exit of the controller coupling mode: Long press on ◀.</p>

6. Other Features

6.1 Anti Grip Feature

The feature is enable using DIP6 (See 3.3). If the valves are not active during a week, a complete exercise is triggered (actuator + pump outputs+ Heat/cool demand sent to the SH-HCM).

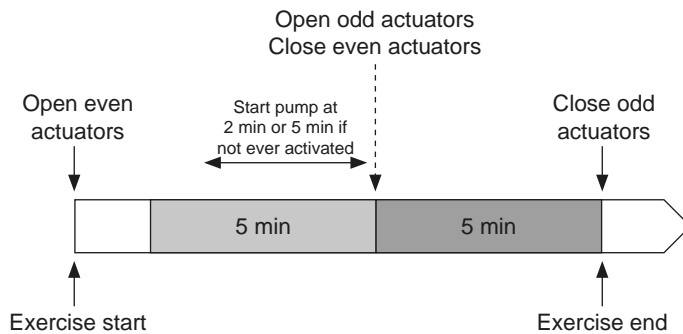

6.2 Reset

In case of dysfunction, it may be required to reset the product to factory setting.

By pressing **▶** for 5 seconds, the master goes in Reset menu. LED of zone 1 starts red blinking, the remaining zone LED start green blinking.

Then by pressing simultaneously on **◀**, **OK** and **▶** up to getting all zone LED in red, the controller reset is triggered and the product restarts. LEDs switch off.

6.3 Trouble shooting

Symptom	Trouble	Description	Trouble shooting
Red or blue blinking on Heat and Cool LED and Red blinking on Pump/Drier LED	Security detection	The contact of the security input is opened	If you not using a security thermostat, make sure, you have installed a strap on the security thermostat input. Otherwise control the temperature of the pipe (too hot in heating mode, too cold in cooling mode)
Red / Blue blinking on Heat and Cool LED	RF Issue	The controller has lost the connection with a RF device other than a thermostat	Check distance between devices. If the controller is installed within a metallic box, use an external antenna located outside the metallic box. A RF repeater may be required.
Fast Blue flashing on Pump/Drier LED	Humidity configuration problem	NTC measurement on H&C input whereas the DIP8 = OFF. ON/OFF input on H&C input whereas the DIP8 = ON	Check if NTC-sensor and DIP switch setting
Red blinking on 1 zone	RF error with the thermostat	The controller has lost the connection with the thermostat.	Check distance between the controller and the thermostat. A RF repeater may be required.
Red blinking on all zones	RF antenna error	The controller has lost all RF connections (Thermostat and other devices)	External antenna may be required.

7. Technical characteristics

7.1 Technical data

	SH-CD6-24, SH-CD6-230, SH-CD10-24, SH-CD10-230
Electrical protection	Class II with functional earth
IP Protection	IP30
Shipping and storage temperature	-10 °C à 50 °C (14 °F à 122 °F)
Power supply	230 V AC ± 10 % 50 Hz
Output maximum load (2 outputs)	Relay : 5 A
Actuators	230 V /24 V NC/NO up to 2 W
Compatibility	SH-AT, SH-DT, SH-DTP, SH--HCM, SH-CU, SH-SM

7.2 Dimensions and weight

SH-CD6-24 and SH-CD6-230:

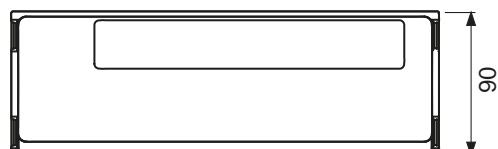
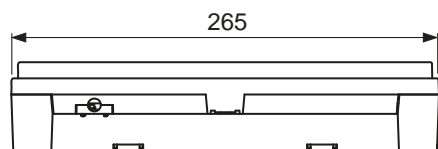

SH-CD10-24 and SH-CD10-230:

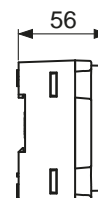
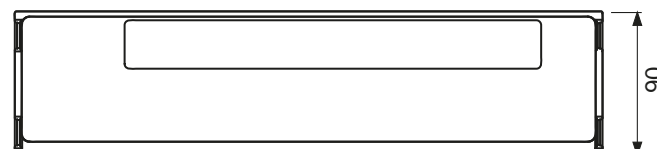
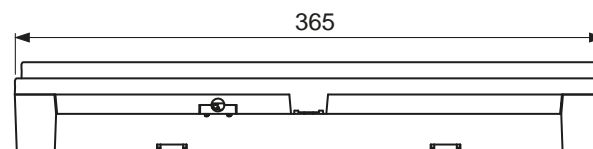

Weight: 840 g - SH-CD6
940 g - SH-CD10

8. Directives

Designation	Description	Link
Low Voltage Directive (LVD)	The Low Voltage Directive (LVD) (2014/35/EU) ensures that electrical equipment within certain voltage limits provides a high level of protection for European citizens, and benefits fully from the Single Market.	2014/35/UE
Electromagnetic Compatibility (EMC) Directive 2014/30/EU	The Electromagnetic Compatibility (EMC) Directive 2014/30/EU ensures that electrical and electronic equipment does not generate, or is not affected by, electromagnetic disturbance.	2014/30/UE
Restriction of the use of certain hazardous substances Directive (RoHS) 2011/65/ EU	Directive on the restriction of the use of certain hazardous substances in electrical and electronic equipment.	2011/65/EU
Waste Electrical & Electronic Equipment Directive (WEEE)	The WEEE Directive (2012/19/EU) aims to reduce the amount of waste electrical and electronic equipment that ends up in landfill.	2012/19/EU
Ecodesign Commission Regulation	Ecodesign requirements for local space heaters.	2015/1188
Radio Equipment Directive (RED) 2014/53/EU	The Radio Equipment Directive 2014/53/EU (RED) establishes a regulatory framework for placing radio equipment on the market.	2014/53/EU

Contenu

1. Informations générales	32
1.1 Avertissements de sécurité et instructions d'utilisation	32
1.2 Application	32
2. Présentation	32
2.1 Fonctions	32
2.2 Contenu de la boîte	33
2.3 Première installation	33
3. Description du produit	33
3.1 Signification des couleurs des LED	33
3.2 Touches	33
3.3 Configuration des interrupteurs DIP	34
3.4 Clé USB	34
4. Entrées / sorties	35
4.1 Alimentation électrique	35
4.2 Entrée chauffage/refroidissement (H&C)	35
4.3 Sortie de la pompe	36
4.4 Contact pour la limitation de la température	36
4.5 Entrée de détection de l'humidité	36
4.6 Actionneurs NC/NO	37
4.7 Antenne externe	38
5. Configuration du système	38
5.1 Configuration du système sans unité centrale	38
5.2 Configuration du système avec l'unité centrale	41
5.3 Contrôlez un déshumidificateur par pièce.	41
6. Autres caractéristiques	42
6.1 Fonction anti-grippage	42
6.2 Remise à zéro	42
6.3 Recherche de pannes	43
7. Caractéristiques techniques	43
7.1 Données techniques	43
7.2 Dimensions et poids	44
8. Directives	44

1. Informations générales

1.1 Avertissements de sécurité et instructions d'utilisation

Ce produit doit être installé de préférence par un professionnel qualifié. Sous réserve du respect des conditions susmentionnées, le fabricant assume la responsabilité de l'équipement conformément aux dispositions légales. Toutes les instructions de ce manuel d'installation et d'utilisation doivent être respectées lors de l'utilisation du contrôleur. Les défaillances dues à une mauvaise installation, à une mauvaise utilisation ou à un mauvais entretien entraînent l'annulation de la responsabilité du fabricant.



Toute tentative de réparation annule la responsabilité et l'obligation de garantie et de remplacement du fabricant. 2012/19/EU (directive DEEE) : Les produits marqués de ce symbole ne peuvent pas être éliminés comme des déchets municipaux non triés dans l'Union européenne. Pour un recyclage adéquat, renvoyez ce produit à votre fournisseur local lors de l'achat d'un nouvel équipement équivalent, ou déposez-le dans les points de collecte prévus à cet effet. Pour plus d'informations, voir : www.recyclethis.info

1.2 Application

Le contrôleur a été conçu pour être utilisé dans des pièces résidentielles, des bureaux et des installations industrielles. Vérifiez que l'installation est conforme aux réglementations en vigueur avant de la mettre en service afin d'assurer une utilisation correcte de l'installation.

2. Présentation

Le boîtier de raccordement SH-CD est spécialement conçu pour contrôler votre système hydraulique de chauffage et de refroidissement par le sol. Il permet une connexion facile et rapide des thermostats et des actionneurs. 4 versions sont disponibles :

	Version 230 V	Version 24 V
6 zones	SH-CD6-230	SH-CD6-24 (nécessite un transformateur externe 230 V/24 V : TRF03 230/24)
10 zones	SH-CD10-230	SH-CD10-24 (nécessite un transformateur externe 230 V/24 V : TRF03 230/24)

2.1 Fonctions

Il intègre de multiples fonctions :

- Montage mural ou sur rail DIN.
- Raccordements rapide de câbles avec dispositif anti traction
- Indication d'état par LED et commutateur DIP pour le réglage de l'appareil.
- Gérer 6 ou 10 zones avec 2 actionneurs par zone.
- Fusion facile des zones sur le même thermostat.
- Configuration de plusieurs systèmes.
- Entrée H&C (230 V et signal contact sec).
- Mesure de la température de l'eau (sonde non fournie) pour la détection de l'humidité.
- Sortie de la pompe ou de la chaudière (230 V et signal libre de potentiel).
- Gestion de l'anti-grip.
- Thermostat de sécurité pour la limitation de la température.
- Antenne RF interne, antenne externe en option.
- Fonctionne avec les actionneurs NC et NO.
- Connectivité USB pour la mise à jour du logiciel et l'enregistrement des données.

2.2 Contenu de la boîte

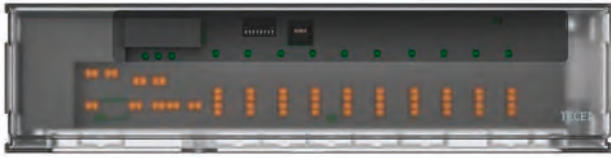

2.3 Première installation

Il y a deux façons d'installer le contrôleur :

1. Montage mural à l'aide de 2 vis.
2. Montage sur rail DIN 35 x 7,5 (DIN EN 60715).

3. Description du produit

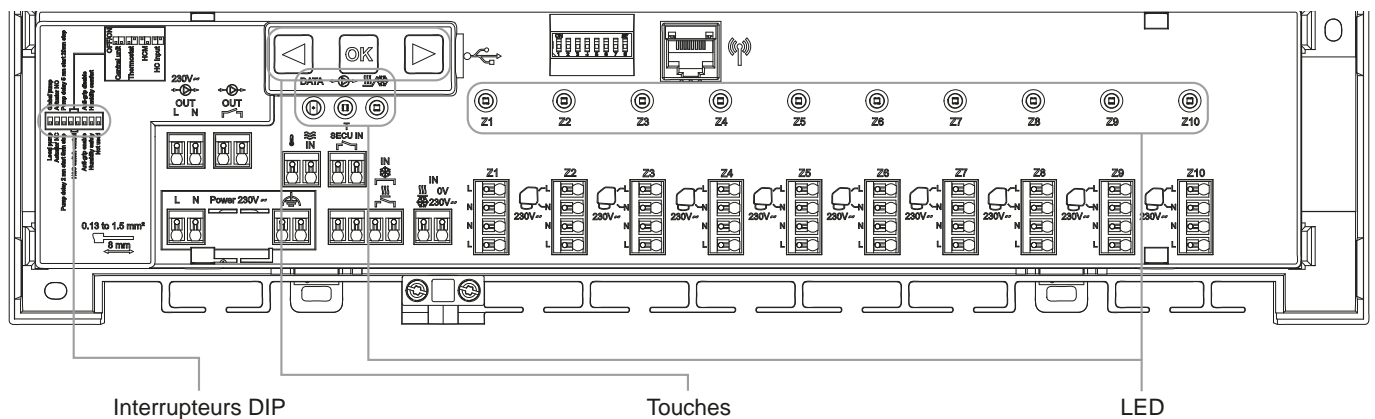

3.1 Signification des couleurs des LED

LED	Signification
LED de chauffage et de refroidissement (Rouge/Bleu)	Rouge fixe = Mode de chauffage. Bleu fixe = Mode de refroidissement. Clignotement rouge (en chauffage) ou bleu (en refroidissement) = Détection de sécurité Rouge/Bleu clignotant = Perte RF (avec SH-CD, SH-HCM, SH-CU, antenne interne). En cas de perte de RF, le système passe en mode chauffage.
LED pompe/sécheur (Vert/Bleu/Rouge)	Vert fixe = La pompe est déclenchée. Rouge clignotant = Erreur du système (détection de sécurité / erreur du capteur d'humidité/...) Bleu clignotant = Détection globale de l'humidité. Bleu clignotant = Problème de configuration de l'humidité.
LED de données (Rouge/Vert)	Vert clignotant = Enregistrement des données en cours.
LED par zone (Rouge/Vert)	Vert clignotant = Transmission/réception RF. Rouge fixe = Demande de chauffage ou de refroidissement dans la zone. Rouge clignotant = Erreur RF avec le thermostat. Clignotement rouge sur toutes les zones = Erreur d'antenne RF. En cas d'erreur RF avec SH-HCM ou SH-CU, le système passe en mode chauffage.

3.2 Touches

3 touches capacitatives sont disponibles.



3.3 Configuration des interrupteurs DIP

Numéro du commutateur DIP	Fonction	Valeur (par défaut : OFF)		Configuration	Description
DIP1	Fonction du contrôleur	OFF		Pompe locale	Voir 4.3
		ON		Pompe mondiale	
DIP2	Types d'actionneurs	OFF		Actionneur NC	Voir 4.6
		ON		Actionneur NO	
DIP3	Retard de démarrage de la pompe (pour le premier actionneur en demande) et retard d'arrêt de l'actionneur (pour le dernier actionneur en demande)	OFF		2 min/5 min	Voir 4.3 et 4.6
		ON		5 min/20 min	
DIP4 et DIP5	Définition du H&C maître	OFF	OFF	Unité centrale SH-CU	Voir 4.2
		OFF	ON	Thermostat maître SH-DT	
		ON	OFF	SH-HCM	
		ON	ON	SH-CD	
DIP6	Anti-grip	OFF		Activé	Voir 6.1
		ON		Désactivé	
DIP7	Gestion de l'humidité	OFF		Approche sécurité	Voir 4.5
		ON		Approche confort	
DIP8	Capteur d'humidité	OFF		Capteur ON/OFF	Voir 4.5
		ON		Sonde de température de l'eau	

3.4 Clé USB



La connectivité USB permet :

- Pour mettre à jour le logiciel du contrôleur.
- Pour enregistrer des données pour la surveillance du système (datalog).

Pour la mise à jour du logiciel, veuillez-vous référer à www.tece.com pour obtenir le fichier, placez le fichier sur une clé USB.

- Insérer la clé USB dans le contrôleur.
- Eteindre et rallumer le contrôleur
- Pendant la mise à jour,
 - Les LED vertes indiquent la mise sous tension de Z1 à Z6/Z10.
 - Toutes les LED deviennent rouges
 - La LED rouge indique que l'alimentation est coupée entre Z6/Z10 et Z1.
- Après la mise à jour, vous pouvez retirer la clé USB.

Pour le dépannage, l'enregistrement des données est utile pour enregistrer les données dans un fichier ASCII stocké sur la clé USB.

En appuyant sur  pendant 5 secondes, le contrôleur entre dans le menu des fonctions. La LED de la première zone clignote en rouge (l'enregistrement des données est activé) ou en vert (l'enregistrement des données est désactivé). Vous pouvez activer ou désactiver l'enregistrement des données en cliquant sur .

Une pression longue sur  permet de quitter le menu des fonctions (sinon il y a un délai de 10 s avant de quitter automatiquement le menu des fonctions).

1 fichier journal est créé tous les 14 jours. Dans ce fichier, un enregistrement est effectué toutes les 10 minutes.

4. Entrées / sorties

4.1 Alimentation électrique

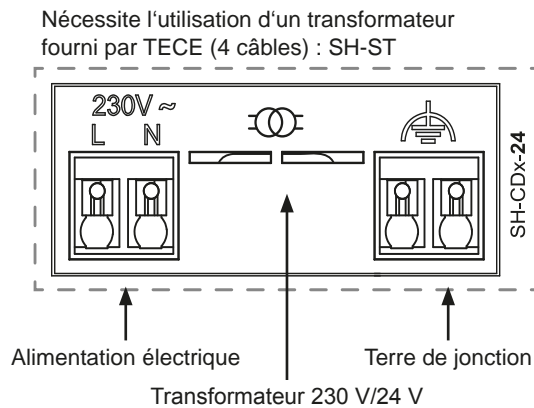
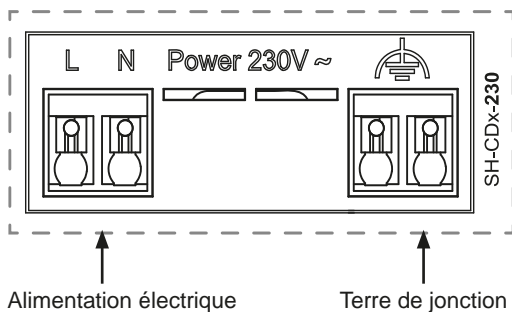

4.2 Entrée chauffage/refroidissement (H&C)

Objet : Cette entrée permet de changer le mode de régulation du système : Chauffage ou refroidissement.

Source du signal :

- Un interrupteur mécanique
- Une pompe à chaleur
- Un SH-SM couplé à l'unité centrale SH-CU comme dispositif ON/OFF. Cette solution permet de contrôler à distance le mode H&C à partir de l'application.

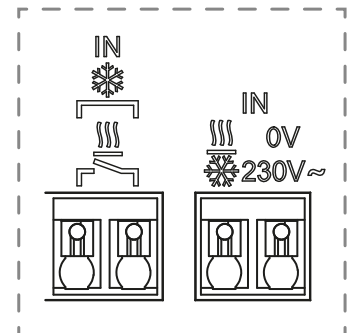

Format du signal : L'entrée peut être à contact libre ou à contact direct 230 V.

Mode	Contact sec	Contact alimenté
Chauffage	Ouvert	Pas de signal
Refroidissement	Fermé	230 V AC

Un seul appareil dans le système doit pouvoir sélectionner le mode H&C. Autre source possible de signal de commutation H&C (voir 3.3)

- Unité centrale (régler le mode manuel H&C dans le menu installateur de la centrale) DIP4/DIP5 = OFF/OFF.
- SH-HCM qui intègre une entrée H&C DIP4/DIP5 = ON/OFF.
- Thermostat numérique configuré comme thermostat maître H&C en mode manuel ou automatique (un seul thermostat par installation) DIP4/DIP5 = OFF/ON.

Si vous avez plusieurs boîtiers de raccordement SH-CD dans le système, le mode H&C doit être contrôlé par un seul contrôleur :

- Sans centrale, le système considère la boîte de connexion maître SH-CD (voir 5.1.2) DIP4/DIP5 = ON/ON.
- Avec la centrale :
 - Si le boîtier de raccordement contrôle le mode H&C, DIP4/DIP5 = ON/ON.
 - Si l'unité centrale contrôle le mode H&C, DIP4/DIP5 = OFF/OFF.

DIP4	DIP5	Signal de commutation Demande H&C par
OFF	OFF	Unité centrale (SH-CU)
OFF	ON	Thermostat
ON	OFF	Module de chauffage et de refroidissement (SH-HCM)
ON	ON	Boîte de connexion (SH-CD)

4.3 Sortie de la pompe

Il y a 2 sorties :

- Sortie contact alimenté (230 V AC)
- Sortie contact sec

Ces sorties peuvent être utilisées pour déclencher :

- Une vanne de zone
- Une pompe
- Une chaudière ou une pompe à chaleur

Les 2 sorties sont déclenchées en cas de demande de chauffage ou de refroidissement :

- Dans le contrôleur, si le commutateur DIP 1 = OFF = local
 - Dans le système, si le commutateur DIP 1 = ON = global
- Voir 3.3

Le délai entre la demande de chauffage ou de refroidissement et l'activation de la pompe est configurable :

- La pompe démarre 2 minutes après la demande de chauffage ou de refroidissement si le commutateur DIP 3 = OFF
 - La pompe démarre 5 minutes après la demande de chauffage ou de refroidissement si le commutateur DIP 3 = ON
- Voir 3.3

L'objectif est de prendre en compte la latence de l'actionneur.

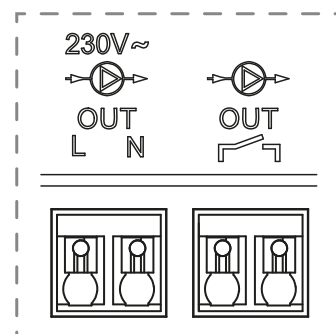

4.4 Contact pour la limitation de la température

Il s'agit d'une entrée de sécurité (contact sec).

Contact fermé	Contact ouvert
Pas de détection de sécurité	Détection de surchauffe ou de sur refroidissement

L'entrée de sécurité doit être utilisée sur un contrôleur avec une pompe.

Lorsque le contact est ouvert :

- La sortie de la pompe locale est arrêtée (même si DIP1=ON, c'est-à-dire pompe globale sur le contrôleur).
- Les actionneurs sont fermés.
- Le voyant de la pompe/deshumidificateur clignote en rouge.
- La LED de chauffage et de refroidissement clignote en rouge (en chauffage) ou en bleu (en refroidissement).
- Si le contrôleur est un contrôleur esclave, la demande de chauffage ou de refroidissement n'est pas envoyée au contrôleur maître.

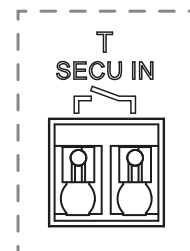

Vous pouvez utiliser un thermostat de contact pour la sécurité thermique. Vous pouvez installer 2 thermostats de contact en série pour assurer une protection contre la surchauffe et le refroidissement excessif (l'entrée de sécurité est valable en mode chauffage et en mode refroidissement).

Le produit est livré avec une pont sur le connecteur.

Veuillez noter que la pompe du SH-HCM est déclenchée lorsqu'au moins une pompe des multiples SH-CD installés dans le système est déclenchée.

4.5 Entrée de détection de l'humidité

Le produit dispose d'une entrée de détection de l'humidité.

2 types de signaux possibles selon DIP8 (Voir 3.3) :

- Un capteur de contact d'humidité.
- Sonde de température de l'eau (CTN 10 kΩ) : Thermostat SH-DTH requis.

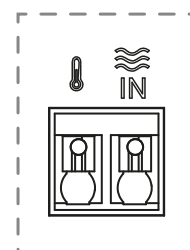

4.5.1 Capteur d'humidité à contact (contrôle du point de rosée)

DIP8 = OFF

Format du signal : L'entrée est un contact sec.

Pas d'humidité	Humidité détectée
Contact ouvert	Contact fermé

En mode refroidissement, lorsque l'humidité est détectée, le contrôleur :

- Arrête le signal de la pompe.
- Ferme tous les actionneurs.
- Envoie l'alarme d'humidité à tous les autres SH-CD du système.
- Demande au SH-HCM d'activer le déshumidificateur.

Si le régulateur est un régulateur s, la demande de refroidissement n'est pas envoyée au régulateur principal.

4.5.2 Sonde de température de l'eau

DIP8 = ON

La mesure de la température de l'eau peut être utilisée de deux manières.

Détection de l'humidité

En mode refroidissement, pour chaque zone, le contrôleur calcule le point de rosée en fonction de la température ambiante et de l'humidité relative envoyées par chaque thermostat (un thermostat avec capteur d'humidité relative est nécessaire). Lorsque la température de l'eau atteint le point de rosée dans une zone, le contrôleur.. :

Approche de la sécurité DIP7 = OFF	Approche du confort DIP7 = ON
Fermer l'actionneur de la zone et arrêter la demande de refroidissement de la zone.	Maintenir l'actionneur de la zone ouvert pendant une heure, puis fermer l'actionneur et arrêter la demande de refroidissement dans la zone si l'alarme d'humidité est toujours déclenchée.

- Activer le déshumidificateur à distance de la zone.
- Demande au module SH-HCM d'activer le déshumidificateur global pendant au moins 15 minutes et jusqu'à la disparition de l'alarme si aucun déshumidificateur à distance n'est disponible dans la zone.

Si le régulateur est un régulateur esclave, la demande de refroidissement de la zone n'est pas envoyée au régulateur principal.

Détection du mode de chauffage et de refroidissement

Lorsque DIP4 = ON et DIP5 = ON (contrôle du commutateur H&C = SH-CD) et DIP8 = ON, la température de l'eau est utilisée pour détecter automatiquement le mode H&C.

- Si la température de l'eau est supérieure à 24 °C, le système est en mode chauffage.
- Si la température de l'eau est inférieure à 20 °C, le système est en mode refroidissement.

Cette fonction est utile lorsque la pompe à chaleur passe automatiquement en mode chauffage ou refroidissement et n'a pas de sortie pour informer le système.

- Si le SH-HCM mesure la température de l'eau :

La température est envoyée au SH-CD qui peut être utilisée s'il n'y a pas de capteur de température de l'eau.

- Si l'entrée H&C = mode froid : Le système passe en mode refroidissement quelle que soit la température de l'eau.

4.6 Actionneurs NC/NO

Connecter un actionneur NF ou NO par connecteur.

- Actionneurs 230 V pour SH-CDx-230
- Actionneurs 24 V pour SH-CDx-24

Le type d'actionneur est défini par le DIP2.

Il est nécessaire d'utiliser le même type pour tous les actionneurs.

Lorsqu'il y a une demande de chauffage ou de refroidissement dans une zone, l'actionneur est déclenché immédiatement.

Lorsque la demande de chauffage ou de refroidissement est arrêtée, le servomoteur est fermé immédiatement, sauf s'il s'agit du dernier servomoteur ouvert dans le régulateur. Dans ce cas, le délai avant de commencer à fermer l'actionneur dépend du DIP3 (Voir 3.3) :

- Si DIP3 = OFF, le système attend 5 minutes avant de fermer le dernier actionneur.
- Si DIP3 = ON, le système attend 20 minutes avant de fermer le dernier actionneur.

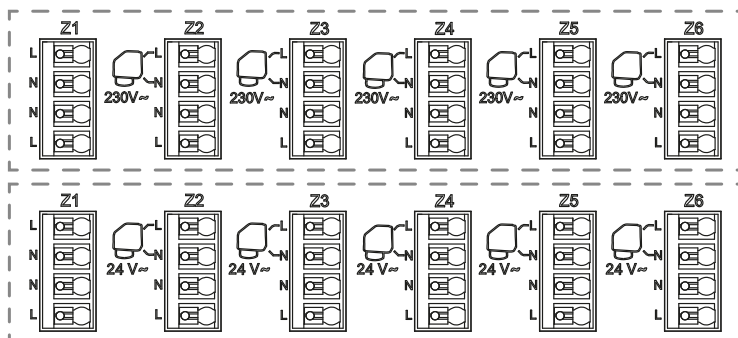

Justification : De nombreuses pompes à chaleur sont dotées d'un délai d'arrêt intégré (pour éviter les arrêts/marches successifs). Dans ce cas, la pompe à chaleur continue de fonctionner pendant x minutes au-delà de l'heure d'arrêt réelle. Il est important de garder au moins un circuit ouvert, à moins qu'il n'y ait un réservoir tampon, un interrupteur hydraulique ou une dérivation dans l'installation.

4.7 Antenne externe

Le contrôleur intègre une antenne interne. Si nécessaire, une antenne externe peut être connectée pour améliorer la communication RF. Cela peut être utile si le contrôleur est installé à l'intérieur d'une boîte métallique. Dans ce cas, vous devez installer l'antenne externe à l'extérieur du boîtier métallique.

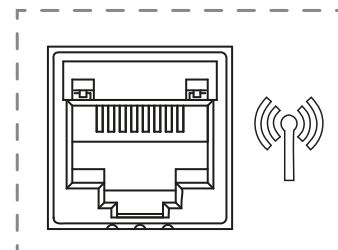

Veuillez respecter le montage afin d'optimiser la sensibilité et d'éviter tout dysfonctionnement.

L'antenne doit être installée :

- en dehors de la boîte métallique
- en position verticale
- et au moins à 50 cm des parties métalliques.

Si vous avez plusieurs antennes (plusieurs contrôleurs), elles doivent être placées à au moins 80 cm l'une de l'autre.

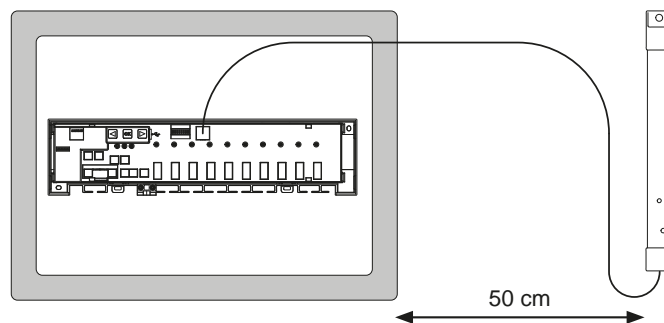





5. Configuration du système

5.1 Configuration du système sans unité centrale

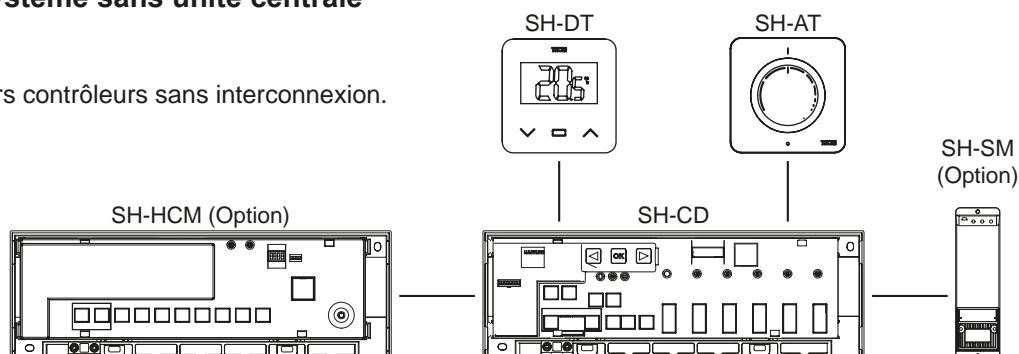
5.1.1 Installation autonome

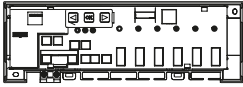
Un seul contrôleur ou plusieurs contrôleurs sans interconnexion.

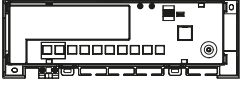
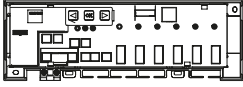

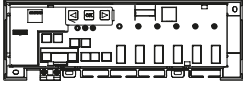
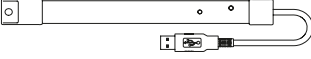
Dispositif 1	Dispositif 2	Remarques
 <p>En appuyant sur OK pendant 5 secondes, le contrôleur passe en mode d'appairage RF.</p> <p>En utilisant ◀ ou ▶, sélectionnez la zone 1 (la LED clignote en rouge), appuyez sur OK pour entrer dans le mode d'appairage avec le thermostat.</p> <p>Une LED verte clignotante est un indicateur de position.</p> <p>Déplacez le voyant vert clignotant avec ◀ ou ▶ pour sélectionner la ou les zones à appairer.</p> <p>Sélectionnez/désélectionnez la zone avec OK.</p> <p>La zone sélectionnée est fixée en rouge mais continue de clignoter en vert (indicateur de position).</p> <p>La zone déjà appariée est fixée en vert.</p>	 <p>Thermostats :</p> <p>Régler le produit en mode d'appairage RF (se référer au manuel d'instructions correspondant).</p>	<p>Si l'appairage RF est effectué, les LED des zones sélectionnées sur le SH-CD doivent s'éteindre et les thermostats doivent quitter le mode d'appairage.</p> <p>Pour appairer un autre thermostat, vous devez entrer/démarrer le mode à nouveau.</p> <p>Quitter le mode de couplage du contrôleur : Appui long sur ◀.</p>
 <p>En appuyant sur OK pendant 5 secondes, le contrôleur entre dans le menu d'appairage RF.</p> <p>En utilisant ◀ ou ▶, sélectionnez la zone 3 (la LED clignote en rouge), appuyez sur OK pour entrer dans le mode d'appairage avec un appareil esclave.</p> <p>Tous les voyants clignotent en vert.</p>	 <p>Réglez l'appareil en mode de couplage RF. Appuyez sur le bouton pendant 10 secondes. Pour plus d'informations, reportez-vous au manuel de l'appareil concerné.</p>	<p>Lorsque la liaison est établie, le SH-CD revient en mode couplage et le SH-HCM revient en mode normal. Quitter le mode de couplage du contrôleur : Appui long sur ◀.</p> <p>REMARQUE : un seul module de refroidissement SH-HCM par installation.</p>
 <p>En appuyant sur OK pendant 5 secondes, le contrôleur entre dans le menu d'appairage RF.</p> <p>En utilisant ◀ ou ▶, sélectionnez la zone 3 (la LED clignote en rouge), appuyez sur OK pour entrer dans le mode d'appairage avec un appareil esclave.</p> <p>Tous les voyants clignotent en vert.</p>	 <p>Réglez le SH-SM sur le mode de couplage RF. Appuyez sur le bouton pendant 5 secondes. Pour plus d'informations, reportez-vous au manuel de l'appareil.</p>	<p>Lorsque la liaison est établie, le SH-SM quitte le mode de couplage. SH-CD revient en mode couplage. Quitter le mode de couplage du contrôleur : Appui long sur ◀.</p>
 <p>En appuyant sur OK pendant 5 secondes, le contrôleur entre dans le menu d'appairage RF.</p> <p>En utilisant ◀ ou ▶, sélectionnez la zone 3 (la LED clignote en rouge), appuyez sur OK pour entrer dans le mode d'appairage avec un appareil esclave.</p> <p>Tous les voyants clignotent en vert.</p>	 <p>Réglez le SH-R sur le mode de couplage RF. Appuyez sur le bouton pendant 3 secondes. Pour plus d'informations, reportez-vous au manuel de l'appareil.</p>	<p>Lorsque la liaison est établie, SH-R quitte le mode de couplage. SH-CD revient en mode couplage. Quitter le mode de couplage du contrôleur : Appui long sur ◀.</p>

5.1.2 Installation de plusieurs contrôleurs

S'il y a plusieurs contrôleurs interconnectés dans l'installation, il y a 1 contrôleur principal (Main SH-CD) et jusqu'à 3 sous-contrôleurs (Sub SH-CD).

Le contrôleur maître centralise les informations pour les contrôleurs esclaves. Si un module SH-HCM est utilisé, il doit être couplé au contrôleur principal.

- Le contrôleur maître transmet le mode de chauffage et de refroidissement aux contrôleurs esclaves. Cette information peut provenir du SH-HCM ou d'un thermostat Master Digital en fonction des DIP4 et DIP5 (Voir 3.3)
- Le contrôleur maître peut gérer le signal de la pompe de l'ensemble de l'installation en fonction de DIP1 (Voir 3.3)

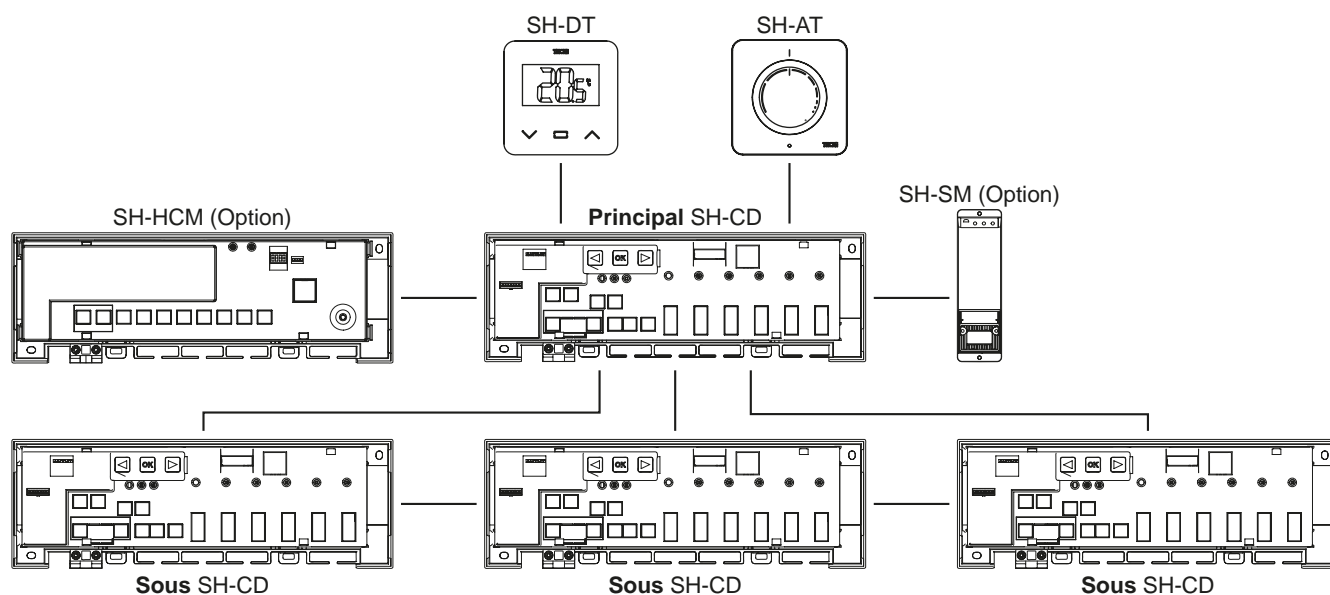

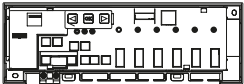
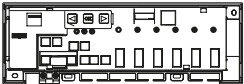
Dispositif 1 : Contrôleur principal	Dispositif 2 : Sous-contrôleur	Remarques
Tout d'abord, tous les thermostats radio doivent être appariés avec le contrôleur RF SH-CD correspondant ! Voir 5.1.1		
 <p>En appuyant sur OK pendant 5 secondes, le contrôleur entre dans le menu d'appairage RF.</p> <p>En utilisant ◀ ou ▶, sélectionnez la zone 3 (la LED clignote en rouge), appuyez sur OK pour entrer dans le mode d'appairage avec un appareil esclave. Tous les voyants clignotent en vert.</p>	 <p>En appuyant sur OK pendant 5 secondes, le contrôleur entre dans le menu d'appairage RF.</p> <p>En utilisant ◀ ou ▶, sélectionnez la zone 2 (la LED clignote en rouge), appuyez sur OK pour entrer dans le mode d'appairage avec un appareil maître.</p> <p>Tous les voyants clignotent en rouge.</p>	<p>Lorsque l'appairage RF est terminé, le SH-CD revient en mode d'appairage. Quitter le menu d'appairage du contrôleur : Appuyer longuement sur ◀.</p>

5.2 Configuration du système avec l'unité centrale

L'unité centrale centralise la communication entre les contrôleurs.

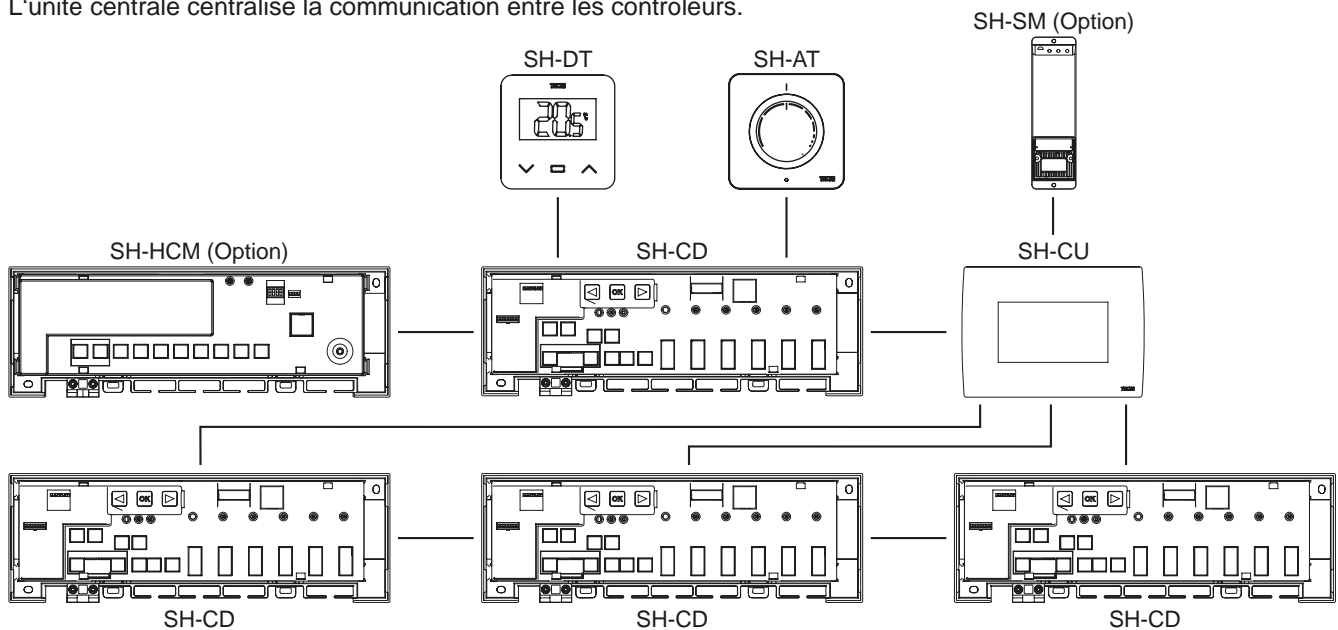

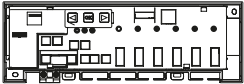
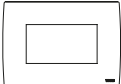
Dispositif 1 : SH-CD	Dispositif 2 : SH-CU	Remarques
Tout d'abord, tous les thermostats radio doivent être appariés avec le contrôleur RF SH-CD correspondant ! Voir 5.1.1		
 <p>En appuyant sur OK pendant 5 secondes, le contrôleur entre dans le menu d'appairage RF.</p> <p>En utilisant ◀ ou ▶, sélectionnez la zone 2 (la LED clignote en rouge), appuyez sur OK pour entrer dans le mode d'appairage avec un appareil maître.</p> <p>Tous les voyants clignotent en rouge.</p>	 <p>Mettez l'appareil en mode d'appairage RF.</p> <p>Sélectionnez une pièce (Pièce 1).</p> <p>Lors du couplage d'un SH-CD avec un SH-CU, une pièce est générée pour chaque thermostat sans fil. Les pièces ne doivent donc pas être créées au préalable dans l'unité centrale.</p>	<p>Lorsque l'appairage RF est terminé, le SH-CD et le SH-CU quittent tous deux le mode d'appairage.</p> <p>Quitter le menu d'appairage du contrôleur : Appuyer longuement sur ◀.</p>

5.3 Contrôlez un déshumidificateur par pièce.

Il existe deux façons de détecter l'humidité :

- Au niveau du contrôleur en utilisant l'entrée de détection de l'humidité (voir 4.5).
- Au niveau de la pièce, si le thermostat intègre un capteur d'humidité relative.

Lorsque l'humidité est détectée, il y a deux façons de déclencher le déshumidificateur :

- Un déshumidificateur global est déclenché par le SH-HCM si la fonction est activée sur le SH-HCM.
- Un déshumidificateur est déclenché au niveau de la pièce où l'humidité est détectée.

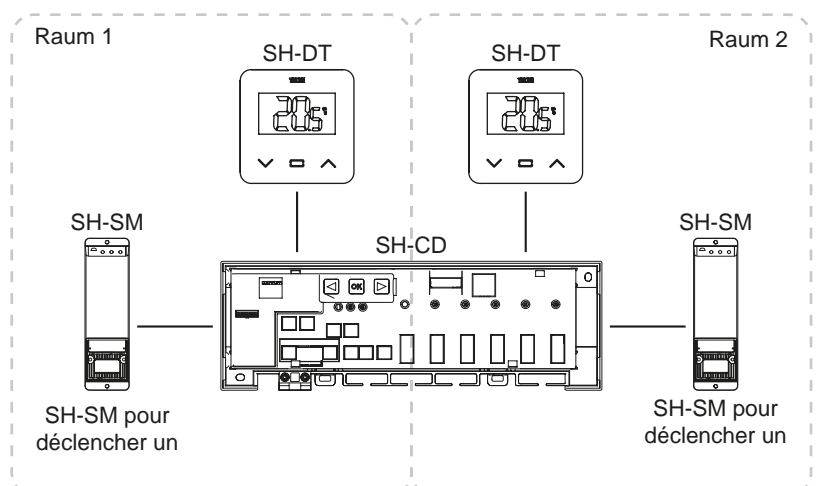

Dans ce cas, vous devez coupler un récepteur RF BT-WR02 à chaque zone du contrôleur pour déclencher un déshumidificateur.

Dispositif 1 : SH-CD	Dispositif 2 : SH-SM	Remarques
<p>En appuyant sur pendant 5 secondes, le contrôleur entre dans le menu d'appairage RF.</p> <p>En utilisant ou , sélectionnez la zone 4 (la LED clignote en rouge), appuyez sur pour entrer dans le mode d'appairage du déshumidificateur.</p> <p>Choisissez les zones avec ou .</p> <p>Les zones sont définies par des canaux de thermostat appariés. Par exemple : TH1 = Z1, TH2 = Z2+Z3 et TH3 = Z4+Z5+Z6. La navigation propose 3 zones pour coupler un déshumidificateur sur (Z1), (Z2+Z3) et (Z4+Z5+Z6). Sélectionnez/désélectionnez la zone à l'aide de . (Vous ne pouvez sélectionner qu'une seule zone par déshumidificateur). Le curseur clignote en vert.</p> <p>La zone sélectionnée clignote en rouge et en vert</p> <p>La zone déjà appariée est fixée en vert. (Pour supprimer un déshumidificateur, sélectionnez une zone en vert, puis appuyez simultanément sur et up pour faire clignoter la zone en vert).</p>	<div style="text-align: center;">  </div> <p>Réglez le SH-SM sur le mode de couplage RF.</p> <p>Appuyez sur le bouton pendant 5 secondes.</p> <p>Pour plus d'informations, reportez-vous au manuel de l'appareil.</p>	<p>Lorsque la liaison est établie, le SH-SM quitte le mode de couplage.</p> <p>SH-CD revient en mode couplage.</p> <p>Quitter le mode de couplage du contrôleur : Appui long sur .</p>

6. Autres caractéristiques

6.1 Fonction anti-grippage

Cette fonction est activée à l'aide du DIP6 (voir 3.3). Si les vannes ne sont pas actives pendant une semaine, un exercice complet est déclenché (actionneur + sorties de pompe + demande de chaleur/refroidissement envoyée au SH-HCM).

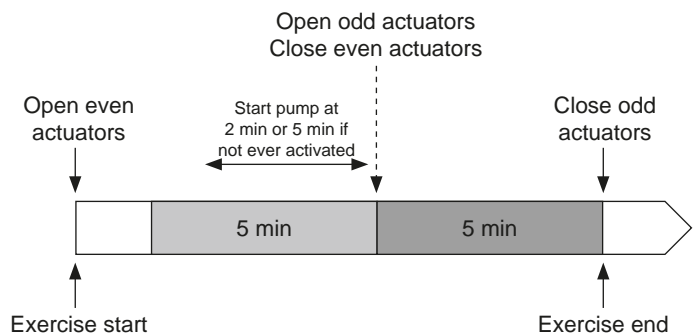

6.2 Remise à zéro

En cas de dysfonctionnement, il peut être nécessaire de réinitialiser le produit aux paramètres d'usine.

En appuyant sur pendant 5 secondes, le contrôleur entre dans le menu Reset. La LED de la zone 1 commence à clignoter en rouge, les LED des autres zones commencent à clignoter en vert.

Ensuite, en appuyant simultanément sur , et jusqu'à ce que toutes les LED de la zone deviennent rouges, la réinitialisation du contrôleur est déclenchée et le produit redémarre. Les LEDs s'éteignent.

6.3 Recherche de pannes

Symptôme	Problèmes	Description	Recherche de pannes
Clignotement rouge ou bleu des DEL de chauffage et de refroidissement et Rouge clignotant sur la LED Pompe/Déshumificateur	Détection de la sécurité	Le contact de l'entrée de sécurité est ouvert	Si vous n'utilisez pas de thermostat de sécurité, assurez-vous que vous avez installé un pont sur l'entrée du thermostat de sécurité. Sinon, contrôlez la température du tuyau (trop chaud en mode chauffage, trop froid en mode refroidissement).
Rouge/Bleu clignotant sur les LED de chauffage et de refroidissement	Problème relatif aux radiofréquences	Le contrôleur a perdu la connexion avec un appareil RF autre qu'un thermostat.	Vérifier la distance entre les appareils. Si le contrôleur est installé dans un boîtier métallique, utiliser une antenne externe située à l'extérieur du boîtier métallique. Un répéteur RF peut être nécessaire.
Clignotement bleu rapide de la LED pompe/sécheur	Problème de configuration de l'humidité	Mesure CTN sur l'entrée H&C lorsque le DIP8 = OFF. Entrée ON/OFF sur l'entrée H&C lorsque le DIP8 = ON	Vérifier si le sonde CTN et le réglage du commutateur DIP sont corrects.
Rouge clignotant sur 1 zone	Erreur RF avec le thermostat	Le contrôleur a perdu la connexion avec le thermostat.	Vérifier la distance entre le contrôleur et le thermostat. Un répéteur RF peut être nécessaire.
Rouge clignotant sur toutes les zones	Erreur d'antenne RF	Le contrôleur a perdu toutes les connexions RF (thermostat et autres dispositifs).	Une antenne externe peut être nécessaire.

7. Caractéristiques techniques

7.1 Données techniques

	SH-CD6-24, SH-CD6-230, SH-CD10-24, SH-CD10-230
Protection électrique	Classe II avec terre fonctionnelle
Protection IP	IP30
Température d'expédition et de stockage	-10 °C à 50 °C (14 °F à 122 °F)
Alimentation électrique	230 V AC ± 10 % 50 Hz
Charge maximale de la sortie (2 sorties)	Relais : 5 A
Actionneurs	230 V /24 V NC/NO jusqu'à 2 W
Compatibilité	SH-AT, SH-DT, SH-DTP, SH-HCM, SH-CU, SH-SM

7.2 Dimensions et poids

SH-CD6-24 et SH-CD6-230

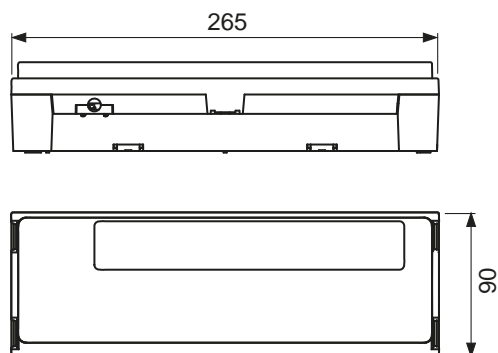

SH-CD10-24 et SH-CD10-230

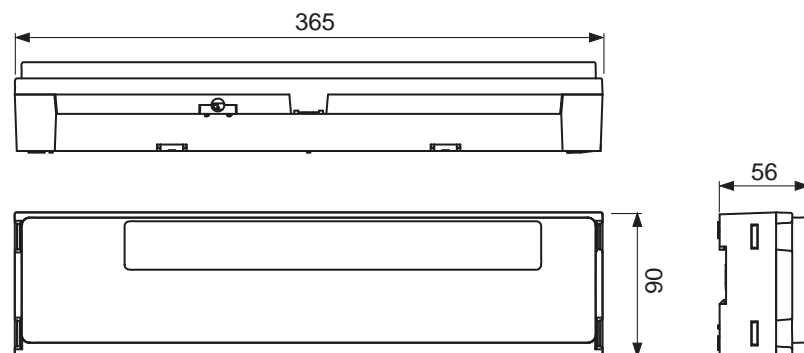

Poids : 840 g - SH-CD6
940 g - SH-CD10

8. Directives

Désignation	Description	Lien
Directive basse tension (DBT)	La directive basse tension (DBT) (2014/35/UE) garantit que les équipements électriques situés dans certaines limites de tension offrent un niveau de protection élevé aux citoyens européens et bénéficient pleinement du marché unique.	2014/35/UE
Compatibilité électromagnétique (CEM) Directive 2014/30/EU	La directive 2014/30/UE sur la compatibilité électromagnétique (CEM) garantit que les équipements électriques et électroniques ne génèrent pas de perturbations électromagnétiques ou ne sont pas affectés par celles-ci.	2014/30/UE
Restriction de l'utilisation de certains substances dangereuses (RoHS) Directive 2011/65/UE	Directive relative à la limitation de l'utilisation de certains substances dangereuses dans les équipements électriques et électroniques l'équipement.	2011/65/UE
Déchets électriques Équipements électroniques Directive sur les déchets d'équipements électriques et électroniques (DEEE)	La directive DEEE (2012/19/EU) vise à réduire la quantité de déchets d'équipements électriques et électroniques mis en décharge.	2012/19/EU
Commission de l'écoconception Règlement	Exigences en matière d'écoconception pour les appareils de chauffage locaux.	2015/1188
Directive relative aux équipements hertziens (RED) 2014/53/EU	La directive 2014/53/UE relative aux équipements hertziens (RED) établit un cadre réglementaire pour la mise sur le marché des équipements hertziens.	2014/53/EU

Índice

1. INFORMACIÓN GENERAL	46
1.1 Advertencias de seguridad e instrucciones de uso	46
1.2 Aplicación	46
2. PRESENTACIÓN	46
2.1 Funciones	46
2.2 Contenido de la caja	47
2.3 Primera instalación	47
3. DESCRIPCIÓN DEL PRODUCTO	47
3.1 Significado del color del LED (marcado en rojo)	47
3.2 Teclas (marca verde)	48
3.3 Configuración del interruptor DIP (marca naranja)	48
3.4 Memoria USB	48
4. ENTRADAS / SALIDAS	49
4.1 Fuente de alimentación	49
4.2 Entrada de calefacción/refrigeración (H&C)	49
4.3 Salida de la bomba	50
4.4 Contacto para limitación de temperatura	50
4.5 Entrada de detección de humedad	50
4.6 Actuadores NC/NO	52
4.7 Antena exterior	52
5. CONFIGURACIÓN DEL SISTEMA	53
5.1 Configuración del sistema sin unidad central	53
5.2 Configuración del sistema con unidad central	55
5.3 Controla un deshumidificador por habitación	56
6. OTRAS CARACTERÍSTICAS	56
6.1 Función antiagarre	56
6.2 Restablecer	57
6.3 Solución de problemas	57
7. CARACTERÍSTICAS TÉCNICAS	57
7.1 Datos técnicos	57
7.2 Dimensiones y peso	58
8. DIRECTIVAS	58

1. INFORMACIÓN GENERAL

1.1 Advertencias de seguridad e instrucciones de uso

Este producto debe ser instalado preferentemente por un profesional cualificado. Sujeto a la observación de los términos anteriores, el fabricante asumirá la responsabilidad del equipo según lo dispuesto por las estipulaciones legales. Todas las instrucciones de este manual de instalación y funcionamiento deben ser leídas cuando se trabaje con el controlador. Los fallos debidos a una instalación incorrecta, un uso inadecuado o un mantenimiento deficiente anulan la responsabilidad del fabricante.



Cualquier intento de reparación anula la responsabilidad y la obligación de garantía y sustitución por parte del fabricante. 2012/19/UE (Directiva RAEE): Los productos marcados con este símbolo no pueden eliminarse como residuos urbanos sin clasificar en la Unión Europea. Para un reciclaje adecuado, devuelva este producto a su proveedor local tras la compra de un equipo nuevo equivalente, o deséchelo en los puntos de recogida designados. Para más información, consulte: www.recyclethis.info

1.2 Aplicación

El controlador ha sido diseñado para su uso en habitaciones residenciales, espacios de oficina e instalaciones industriales. Verifique que la instalación cumple la normativa vigente antes de ponerla en funcionamiento para garantizar un uso adecuado de la misma.

2. PRESENTACIÓN

La caja de conexiones SH-CD está especialmente diseñada para controlar su sistema de calefacción y refrigeración por suelo radiante. Permite una conexión fácil y rápida de termostatos y actuadores. Hay 4 versiones disponibles:

	Versión 230 V	Versión de 24 V
6 zonas	SH-CD6-230	SH-CD6-24 (Requiere transformador externo 230 V/24 V: TRF03 230/24)
10 zonas	SH-CD10-230	SH-CD10-24 (Requiere transformador externo 230 V/24 V: TRF03 230/24)

2.1 Funciones

Ha integrado múltiples funciones:

- Montaje en pared o en carril DIN.
- Conexiones de cable a presión con descarga de tracción.
- Indicador LED de estado e interruptor DIP para ajustar el dispositivo.
- Gestiona 6 ó 10 zonas con 2 actuadores por zona.
- Fácil integración de las zonas en el mismo termostato.
- Configuración de múltiples sistemas.
- Entrada H&C (230 V y señal sin tensión).
- Medición de la temperatura del agua (sonda no suministrada) para la detección de la humedad.
- Salida de bomba o caldera (230 V y señal sin tensión).
- Gestión antiagarre.
- Contacto para limitar la temperatura.
- Antena RF interna, antena externa opcional.
- Funciona con actuadores NC y NO.
- Conectividad USB para actualización de software y registro de datos.

2.2 Contenido de la caja



2.3 Primera instalación

Hay 2 maneras de instalar el controlador:

- Montaje en pared mediante 2 tornillos.
- Montaje en carril DIN.

3. DESCRIPCIÓN DEL PRODUCTO

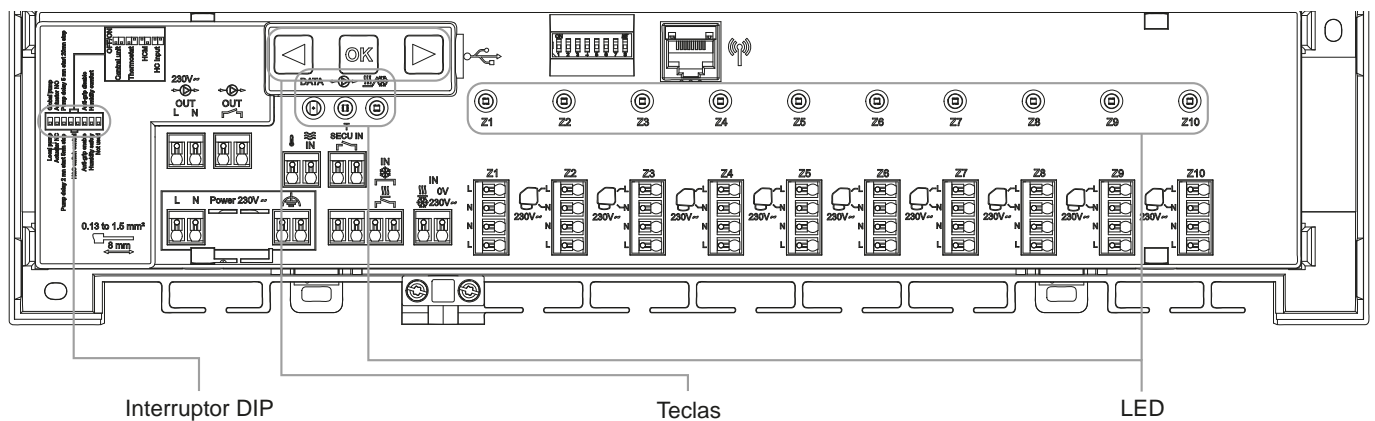

3.1 Significado del color del LED (marcado en rojo)

LED	Significado
LED de calor y frío (rojo/azul)	Rojo fijo = Modo calefacción. Azul fijo = Modo refrigeración. Rojo intermitente (en calefacción) o azul intermitente (en refrigeración) = Detección de seguridad Rojo / Azul parpadeante = Pérdida de RF (con SH-CD, SH-HCM, antena interna). En caso de pérdida de RF, el sistema pasa al modo Calefacción.
Bomba/Secador LED (Verde/Azul/Rojo)	Verde fijo = Bomba activada. Rojo parpadeante = Error del sistema (detección de seguridad / error del sensor de humedad/...) Azul parpadeante = Detección global de humedad. Azul parpadeante = Problema de configuración de la humedad.
LED de datos (Rojo/Verde)	Verde parpadeante = Registro de datos en curso.
LED por zona (Rojo/Verde)	Verde intermitente = Transmisión/recepción RF. Rojo fijo = Demanda de calefacción o refrigeración en la zona. Rojo parpadeante = Error de radiofrecuencia con el termostato. Rojo parpadeante en todas las zonas = Error de antena RF. En caso de error RF con SH-HCM o SH-CU, el sistema conmuta en modo Calefacción.

3.2 Teclas (marca verde)

Dispone de 3 teclas capacitivas.



3.3 Configuración del interruptor DIP (marca naranja)

Número del interruptor DIP	Función	Valor (por defecto: OFF)		Configuración	Descripción
DIP1	Función del controlador	Descripción		Bomba local	Véase 4.3
		ON		Bomba global	
DIP2	Tipos de actuadores	OFF		Actuador NC	Véase 4.6
		ON		Actuador NO	
DIP3	Retardo de arranque de la bomba (para el primer actuador en demanda) y retardo de parada del actuador (para el último actuador en demanda)	OFF		2 min/5 min	Véase 4.3 y 4.6
		ON		5 min/20 min	
DIP4 y DIP5	Control del interruptor H&C	OFF	OFF	Unidad central SH-CU	Véase 4.2
		OFF	ON	Termostato principal SH-DT	
		ON	OFF	SH-HCM	
		ON	ON	SH-CD	
DIP6	Antiagarre	OFF		Activado	Véase 6.1
		ON		Discapacitados	
DIP7	Gestión de la humedad	OFF		Enfoque de seguridad	Véase 4.5
		ON		Enfoque de confort	
DIP8	Sensor de humedad	OFF		Sensor ON/OFF	Véase 4.5
		ON		Sensor de temperatura del agua	

3.4 Memoria USB

La conectividad USB permite:

- Para actualizar el software del controlador.
- Para registrar datos para la supervisión del sistema (registro de datos).

Para actualizar el software, consulte tece.com para obtener el archivo y colóquelo en una memoria USB.

- Inserte la memoria USB en el controlador.
- Apague y encienda el controlador.
- Durante la actualización,
 - LED verde encendido de Z1 a Z6/Z10
 - Todos los LED se vuelven rojos
 - LED rojo apagado de Z6/Z10 a Z1

- Después de la actualización, puede retirar la memoria USB.

Para la resolución de problemas, el registro de datos es útil para grabar datos en un archivo ASCII almacenado en la mochila USB para la resolución de problemas. Pulsando durante 5 segundos, el máster entra en el menú Características. El LED de la primera zona parpadea en rojo (registro de datos activado) o en verde (registro de datos desactivado). Puede activar o desactivar el registro de datos pulsando . Una pulsación larga en permite salir del menú de funciones (de lo contrario, hay un tiempo de espera de 10 s antes de salir automáticamente del menú de funciones)

Se crea un archivo de registro cada 14 días. En el archivo, se hace un registro cada 10 min.

4. ENTRADAS / SALIDAS

4.1 Fuente de alimentación

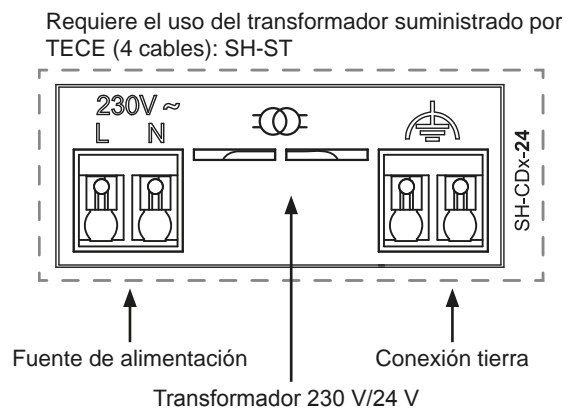
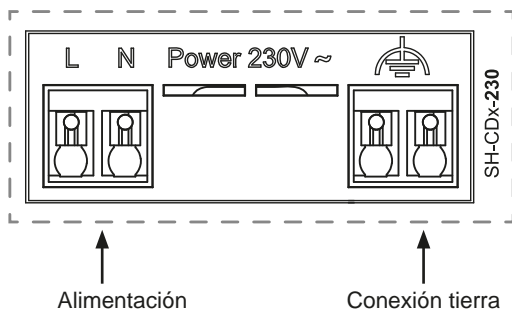

4.2 Entrada de calefacción/refrigeración (H&C)

Propósito:

Esta entrada permite cambiar el modo de regulación del sistema: Calefacción o refrigeración.

Fuente de la señal:

- Un interruptor mecánico
- Una bomba de calor
- Un SH-SM emparejado en la unidad central SH-CU como dispositivo ON/OFF. Esta solución permite obtener un control remoto del modo H&C desde la aplicación.

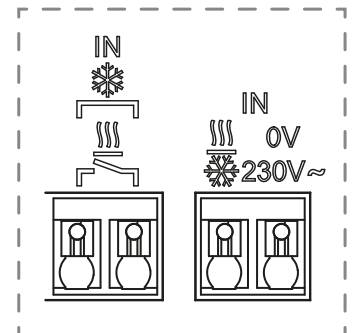

Formato de la señal: La entrada puede ser de contacto libre o de contacto energizado de 230 V.

Modo	Contacto libre	Contacto energizado
Calefacción	Abierto	No hay señal
Refrigeración	Cerrado	230 Vac

Sólo un dispositivo del sistema debe poder seleccionar el modo H&C. Otra posible fuente de señal de conmutación H&C (Ver 3.3)

- Unidad central (ajustar modo manual H&C en el menú de instalador de la central) DIP4/DIP5 = OFF/OFF.
- SH-HCM que incorpora una entrada H&C DIP4/DIP5 = ON/OFF.
- Termostato digital configurado como termostato Master H&C en modo manual o automático (sólo un termostato por instalación) DIP4/DIP5 = OFF/ON.

Si tiene varias cajas de conexión SH-CD en el sistema, el modo H&C debe ser controlado por un solo controlador:

- Sin central, el sistema considera la Caja de Conexión configurada como Master SH-CD (por favor, consulte 5.1.2) DIP4/DIP5 = ON/ON.
- Con central:
 - Si la caja de conexiones controla el modo H&C, DIP4/DIP5 = ON/ON.
 - Si la unidad central controla el modo H&C, DIP4/DIP5 = OFF/OFF.

DIP4	DIP5	Señal de cambio H&C solicitada por
OFF	OFF	Unidad central (SH-CU)
OFF	ON	Termostato
ON	OFF	Módulo Frío&Calor (SH-HCM 230)
ON	ON	Caja de conexiones (SH-CD)

4.3 Salida de la bomba

Hay 2 salidas:

- Salida de contacto energizado (230 Vac)
- Salida de contacto libre

Estas salidas se pueden utilizar para activar:

- Una válvula de zona
- Una bomba
- Una caldera o bomba de calor

Las 2 salidas se activan cuando hay una demanda de calefacción o refrigeración:

- En el controlador si el interruptor DIP 1 = OFF = local
- En el sistema si interruptor DIP 1 = ON = global

Véase 3.3

El retardo entre la demanda de calefacción o refrigeración y la activación de la bomba es configurable:

- La bomba arranca 2 minutos después de la demanda de calefacción o refrigeración si el interruptor DIP 3 = OFF
- La bomba arranca 5 minutos después de la demanda de calefacción o refrigeración si el interruptor DIP 3 = ON

Véase 3.3

El objetivo es verificar el funcionamiento del actuador.

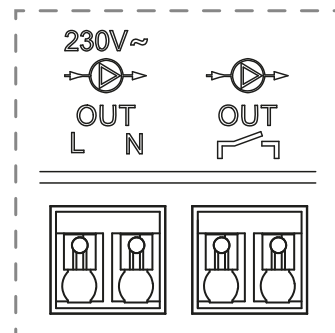

4.4 Contacto para limitación de temperatura

Se trata de una entrada de seguridad (Contacto libre).

Contacto cerrado	Contacto abierto
Sin detección de seguridad	Detección de sobrecalentamiento o sobreenfriamiento

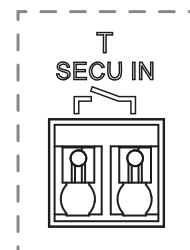

La entrada de seguridad debe utilizarse en un controlador con bomba.

Cuando se abre el contacto:

- La salida de la bomba local se detiene (incluso si DIP1=ON, es decir, bomba global en el controlador).
- Los actuadores están cerrados.
- El LED de la bomba/deshumidificadora parpadea en rojo.
- El LED de calor y frío parpadea en rojo (en calefacción) o en azul (en refrigeración).
- Si el controlador es un subcontrolador, la demanda de calefacción o refrigeración no se envía al controlador principal.

Puede utilizar un termostato de contacto para la seguridad térmica. Puede instalar 2 termostatos de contacto en serie para protegerse tanto del sobrecalentamiento como del sobreenfriamiento (La entrada de seguridad es válida tanto en modo calefacción como refrigeración).

El producto de serie lleva instalado un cable-puente en el conector.

Tenga en cuenta que la bomba de la SH-HCM se activa cuando se activa al menos una bomba de las múltiples SH-CD instaladas en el sistema.

4.5 Entrada de detección de humedad

El producto dispone de una entrada de detección de humedad.

2 posibles tipos de señal según DIP8 (Ver 3.3):

- Un sensor de contacto de humedad.
- Sensor de temperatura del agua (CTN 10 kΩ): Requiere termostato SH-DTH.

4.5.1 Sensor de contacto de humedad (control del punto de rocío)

DIP8 = OFF

Formato de la señal: La entrada es un contacto libre.

Sin humedad	Humedad detectada
Contacto abierto	Contacto cerrado

En modo refrigeración, cuando se detecta humedad, el controlador:

- Detiene la señal de la bomba.
- Cierra todos los actuadores.
- Envía la alarma de humedad a todos los demás SH-CD del sistema.
- Solicita al SH-HCM que habilite el deshumidificador.

Si el controlador es un subcontrolador, la demanda de refrigeración no se envía al controlador principal.

4.5.2 Sensor de temperatura del agua

DIP8 = ON

Hay 2 usos de la medición de la temperatura del agua.

Detección de humedad

En modo refrigeración, para cada zona, la unidad base calcula el punto de rocío en función de la temperatura ambiente y la humedad relativa enviadas por cada termostato (se requiere termostato con sensor de humedad relativa).

Cuando la temperatura del agua alcanza el punto de rocío en una zona, el controlador:

Modo seguridad DIP7 = OFF	Modo confort DIP7 = ON
Cierre el actuador de la zona y detenga la demanda de refrigeración de la zona.	Mantenga el actuador de la zona abierto durante una hora y, a continuación, cierre el actuador y detenga la demanda de refrigeración en la zona si la alarma de humedad sigue activada.

- Habilitar deshumidificador remoto de la zona.
- Solicita al módulo calor&frío SH-HCM que habilite el deshumidificador global durante al menos 15 min y hasta la desaparición de la alarma si no se dispone de deshumidificador remoto en la zona.

Si el controlador es un subcontrolador, la demanda de refrigeración de la zona no se envía al controlador principal.

Detección del modo de calefacción y refrigeración

Cuando DIP4 = ON y DIP5 = ON (control del interruptor H&C = SH-CD) y DIP8 = ON la temperatura del agua se utiliza para detectar automáticamente el modo H&C.

- Si la temperatura del agua es > 24 °C, el sistema está en modo calefacción.
- Si la temperatura del agua es < 20 °C, el sistema está en modo refrigeración.

Esta función es útil cuando la Bomba de Calor conmuta automáticamente en modo calefacción o refrigeración y no tiene salida para informar al sistema.

- Si el SH-HCM mide la temperatura del agua:
- La temperatura se envía al SH-CD que se puede utilizar si no hay sensor de temperatura del agua.
- Si la entrada H&C = modo frío: El sistema cambia a modo refrigeración independientemente de la temperatura del agua.

4.6 Actuadores NC/NO

Conecte un actuador NC o NO por conector.

- Actuadores de 230 V para SH-CD-230
- Actuadores de 24 V para SH-CD-24

El tipo de actuadores se define mediante DIP2.

Es necesario utilizar el mismo tipo para todos los actuadores.

Cuando hay una demanda de calefacción o refrigeración en una zona, el actuador se activa inmediatamente.

Cuando se detiene la demanda de calefacción o refrigeración, el actuador se cierra inmediatamente, excepto si se trata del último actuador abierto en el regulador. En ese caso, el retardo antes de empezar a cerrar el actuador depende del DIP3 (Ver 3.3):

- Si DIP3 = OFF, el sistema espera 5 min antes de cerrar el último actuador
- Si DIP3 = ON, el sistema espera 20 min antes de cerrar el último actuador

Motivo : Muchas bombas de calor tienen un retardo de apagado incorporado (para evitar apagados y encendidos sucesivos). En este caso, la bomba de calor sigue funcionando durante x minutos más allá del tiempo de desconexión real. Es importante mantener al menos un circuito abierto, a menos que haya un depósito de inercia, un interruptor hidráulico o un bypass en la instalación.

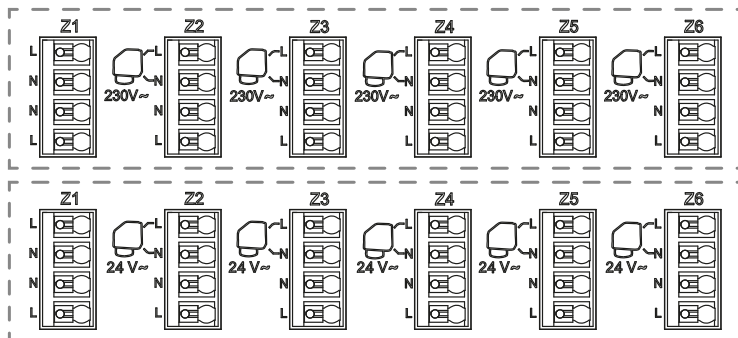

4.7 Antena exterior

El controlador incorpora una antena interna.

Si es necesario, puede conectarse una antena externa para mejorar la comunicación por radiofrecuencia. Puede ser útil si el controlador está instalado dentro de una caja metálica. En ese caso, deberá instalar la antena externa fuera de la caja metálica.

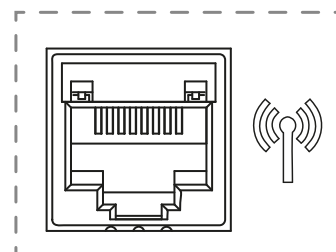

Por favor, respete el montaje para optimizar la sensibilidad y evitar cualquier error.

La antena debe estar instalada:

- fuera de la caja metálica
- en posición vertical
- y al menos a 50 cm de las partes metálicas.

Si tiene varias antenas (varios controladores), deben colocarse a una distancia mínima de 80 cm entre sí.

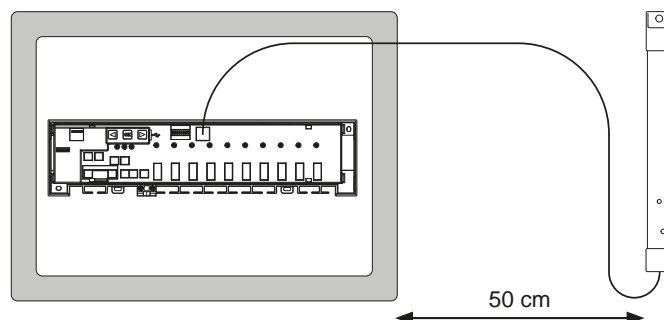



5. CONFIGURACIÓN DEL SISTEMA

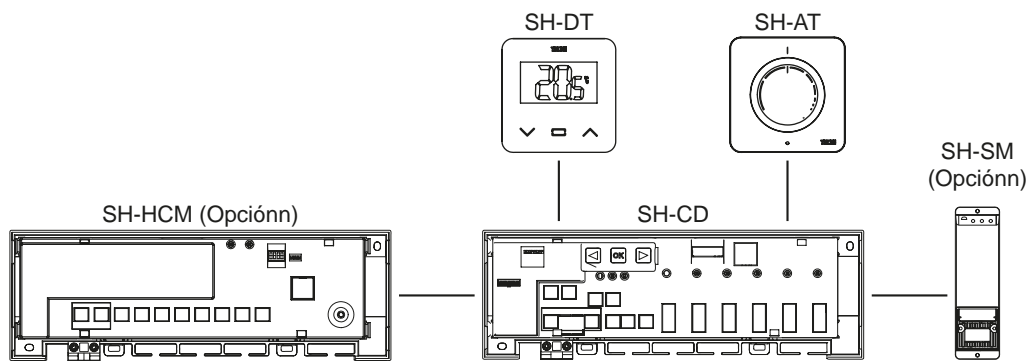

5.1 Configuración del sistema sin unidad central

5.1.1 Instalación autónoma

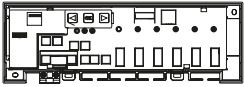
Sólo un controlador o varios controladores sin interconexión.

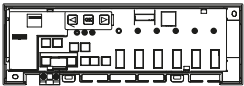
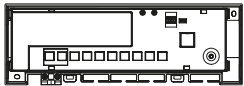

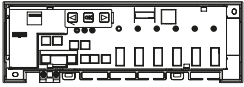
Dispositivo 1	Dispositivo 2	Observaciones
 <p>Pulsando OK durante 5 segundos, el mando entra en modo de emparejamiento RF.</p> <p>Mediante ◀ o ▶ seleccione la zona 1 (el LED parpadea en rojo), pulse OK para entrar en modo Emparejamiento con termostato.</p> <p>Un LED verde parpadeante es un indicador de posición.</p> <p>Mueva el LED verde parpadeante con ◀ o ▶ para seleccionar la(s) zona(s) que desea emparejar.</p> <p>Seleccione/deseleccione la zona con OK.</p> <p>La zona seleccionada se fija en rojo pero sigue parpadeando en verde (indicador de posición).</p> <p>La zona ya emparejada se fija en verde.</p>	 <p>Termostatos: Ponga el producto en modo de emparejamiento por radiofrecuencia (consulte el manual de instrucciones correspondiente).</p>	<p>Si se realiza el emparejamiento RF, los LEDs de las zonas seleccionadas en el SH-CD deben apagarse y los termostatos deben salir del modo de emparejamiento.</p> <p>Para emparejar otro termostato, es necesario volver a entrar/iniciar el modo.</p> <p>Salida del modo de acoplamiento del controlador: Pulsación larga en ◀.</p>
 <p>Pulsando OK durante 5 segundos, el mando entra en el menú de emparejamiento RF.</p> <p>Mediante ◀ o ▶ seleccione la zona 3 (el LED parpadea en rojo), pulse OK para entrar en modo Emparejamiento con un dispositivo esclavo.</p> <p>Todos los LED parpadean en verde.</p>	 <p>Ponga el aparato en modo acoplamiento RF. Pulse el botón durante 10 segundos.</p> <p>Para más información, consulte el manual del aparato correspondiente.</p>	<p>Una vez finalizado el enlace, el SH-CD vuelve al modo de acoplamiento y el SH-HCM vuelve al modo normal.</p> <p>Salida del modo de acoplamiento del controlador: Pulsación larga en ◀.</p> <p>OBSERVACIÓN: sólo un módulo de refrigeración por calor SH-HCM por instalación.</p>

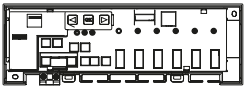
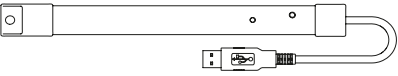
Dispositivo 1	Dispositivo 2	Observaciones
 <p>Pulsando OK durante 5 segundos, el mando entra en el menú de emparejamiento RF.</p> <p>Mediante ◀ o ▶ seleccione la zona 3 (el LED parpadea en rojo), pulse OK para entrar en modo Emparejamiento con un dispositivo esclavo.</p> <p>Todos los LED parpadean en verde.</p>	 <p>Ponga el SH-SM en modo de emparejamiento RF.</p> <p>Pulse el botón durante 5 segundos.</p> <p>Para más información, consulte el manual del aparato.</p>	<p>Cuando se realiza el enlace, SH-SM sale del modo de emparejamiento.</p> <p>SH-CD vuelve al modo de emparejamiento.</p> <p>Salida del modo de acoplamiento del controlador: Pulsación larga en ◀.</p>
 <p>Pulsando OK durante 5 segundos, el mando entra en el menú de emparejamiento RF.</p> <p>Mediante ◀ o ▶ seleccione la zona 3 (el LED parpadea en rojo), pulse OK para entrar en modo Emparejamiento con un dispositivo esclavo.</p> <p>Todos los LED parpadean en verde.</p>	 <p>Ponga el SH-R en modo de emparejamiento RF.</p> <p>Pulse el botón durante 3 segundos.</p> <p>Para más información, consulte el manual del aparato.</p>	<p>Cuando se realiza el enlace, SH-R sale del modo de emparejamiento.</p> <p>SH-CD vuelve al modo de emparejamiento.</p> <p>Salida del modo de emparejamiento del controlador: Pulsación larga en ◀.</p>

5.1.2 Instalación de varios controladores

Si hay varios controladores interconectados en la instalación, hay 1 controlador principal (SH-CD **Master**) y hasta 3 sub-controladores (SH-CD **Slave**).

El controlador principal centraliza la información para los Slaves. Si se utiliza un módulo de refrigeración por calor SH-HCM, debe emparejarse con el controlador principal.

- El controlador principal propaga el modo Calor y Frío a los Slaves. Esta información puede venir del SH-HCM o de un termostato Master Digital según los DIP4 y DIP5 (Ver 3.3)
- El controlador principal podría manejar la señal de la bomba de toda la instalación según DIP1 (Ver 3.3)

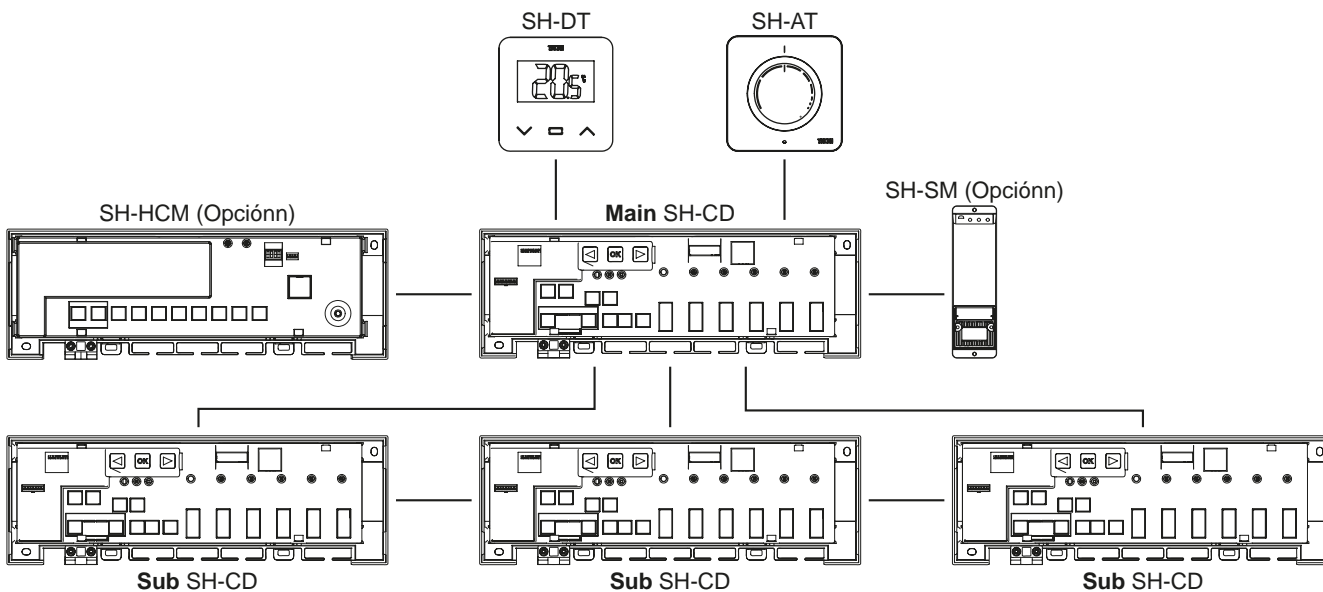

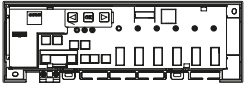
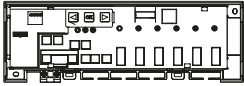
Dispositivo 1: Controlador principal	Dispositivo 2: Subcontrolador	Observaciones
<p>En primer lugar, todos los termostatos por radio deben emparejarse con el controlador RF SH-CD correspondiente. Véase 5.1.1</p>		
 <p>Pulsando OK durante 5 segundos, el mando entra en el menú de emparejamiento RF. Mediante ◀ o ▶ seleccione la zona 3 (el LED parpadea en rojo), pulse OK para entrar en modo Emparejamiento con un dispositivo esclavo. Todos los LED parpadean en verde.</p>	 <p>Pulsando OK durante 5 segundos, el mando entra en el menú de emparejamiento RF. Mediante ◀ o ▶ seleccione la zona 2 (el LED parpadea en rojo), pulse OK para entrar en modo Emparejamiento con un dispositivo maestro. Todos los LED parpadean en rojo.</p>	<p>Una vez finalizado el emparejamiento por RF, ambos SH-CD vuelven al modo de emparejamiento. Salida del menú de emparejamiento del mando: Pulsación larga en ◀.</p>

5.2 Configuración del sistema con unidad central

La unidad central centraliza la comunicación entre controladores.

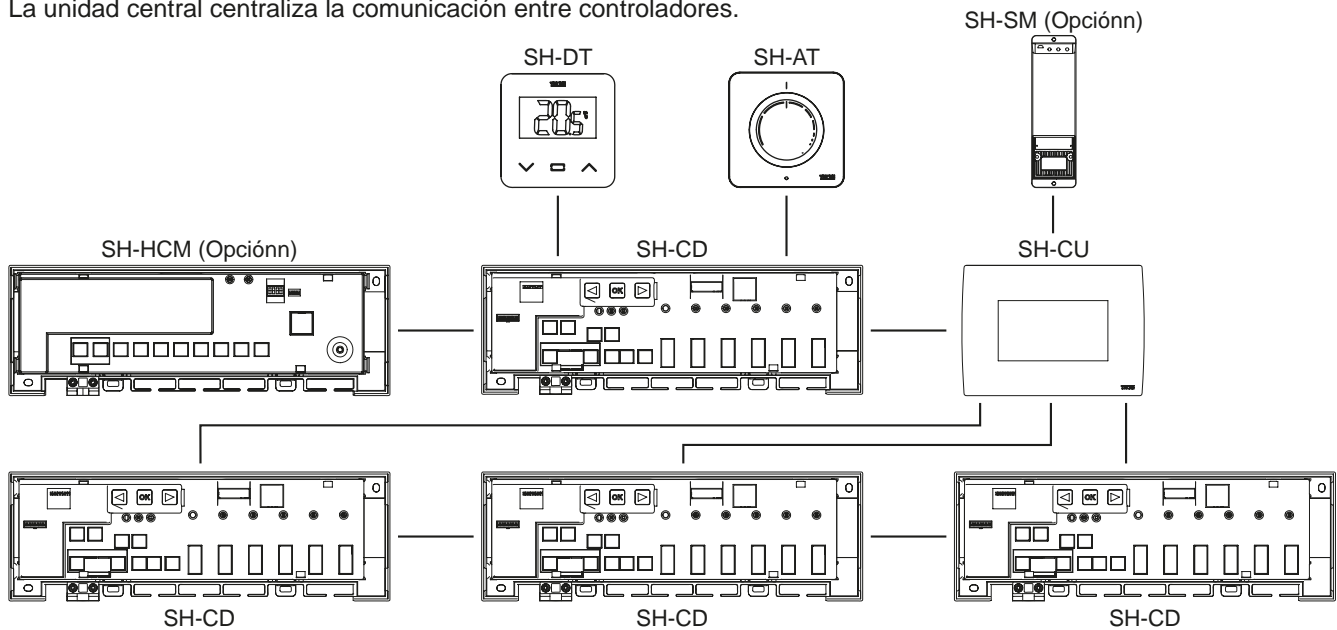

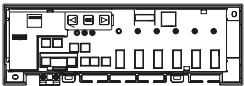
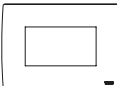
Dispositivo 1: SH-CD	Dispositivo 2: SH-CU	Observaciones
<p>En primer lugar, todos los termostatos por radio deben emparejarse con el controlador RF SH-CD correspondiente. Véase 5.1.1</p>		
 <p>Pulsando OK durante 5 segundos, el mando entra en el menú de emparejamiento RF. Mediante ◀ o ▶ seleccione la zona 2 (el LED parpadea en rojo), pulse OK para entrar en modo Emparejamiento con un dispositivo maestro. Todos los LED parpadean en rojo.</p>	 <p>Pon el dispositivo en modo de emparejamiento por radiofrecuencia. Seleccione una habitación (Habitación 1). Al emparejar un SH-CD con un CT-02 RF, se genera una habitación para cada termostato inalámbrico. Por lo tanto, las habitaciones no deben crearse previamente en la unidad central.</p>	<p>Una vez realizado el emparejamiento por RF, tanto la SH-CD como la SH-CU salen del modo de emparejamiento. Salida del menú de emparejamiento del mando: Pulsación larga en ◀.</p>

5.3 Controla un deshumidificador por habitación

Hay 2 formas de detectar la humedad:

- A nivel del controlador utilizando la entrada de detección de humedad (Ver 4.5).
- A nivel de habitación, si el termostato incorpora un sensor de humedad relativa.

Cuando se detecta humedad, hay 2 formas de activar el deshumidificador:

- El SH-HCM activa un deshumidificador global si la función está activada en el SH-HCM.
- Un deshumidificador se activa en el nivel de la habitación donde se detecta la humedad.

En ese caso, es necesario emparejar un receptor SH-SM en cada zona del controlador para activar un deshumidificador.

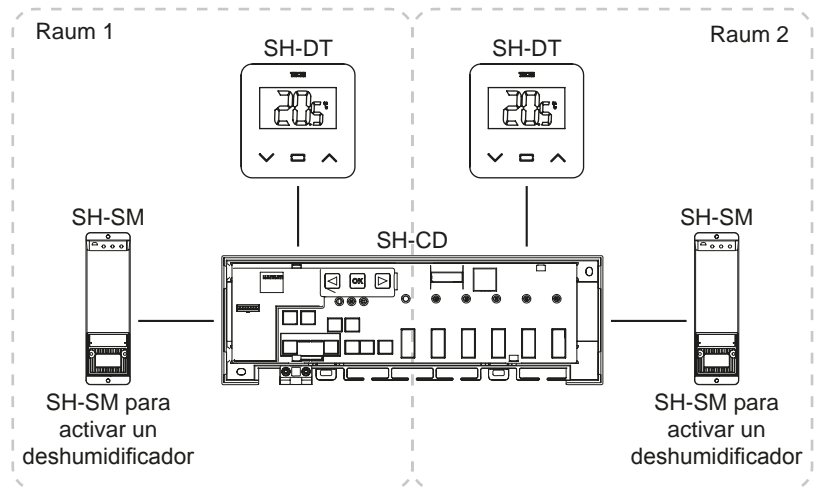

Gerät 1: SH-CD	Gerät 2: SH-SM	Bemerkungen
<p>Pulsando OK durante 5 segundos, el mando entra en el menú de emparejamiento RF. Utilizando ◀ o ▶ seleccione la zona 4 (el LED parpadea en rojo), pulse OK para entrar en el modo de emparejamiento del deshumidificador. Elija las zonas con ◀ o ▶. Las zonas se definen por canales de termostato emparejados. Por ejemplo: TH1 = Z1, TH2 = Z2+Z3 y TH3 = Z4+Z5+Z6. La navegación propone 3 zonas para emparejar un deshumidificador en (Z1), (Z2+Z3) y (Z4+Z5+Z6). Seleccione/deseleccione la zona con OK. (Sólo puede seleccionar una zona por deshumidificador). El cursor parpadea en verde. La zona seleccionada parpadea en rojo y verde. La zona ya emparejada se fija en verde. (Para quitar un deshumidificador, seleccione una zona en verde, luego pulse simultáneamente en ◀ y ▶ arriba para que la zona parpadee en verde)</p>	 <p>Ponga el SH-SM en modo de acoplamiento RF. Pulse el botón durante 5 segundos. Para más información, consulte el manual del aparato.</p>	<p>Cuando se realiza el enlace, SH-SM sale del modo de acoplamiento. SH-CD vuelve al modo de acoplamiento. Salida del modo de acoplamiento del controlador: Pulsación larga en ◀.</p>



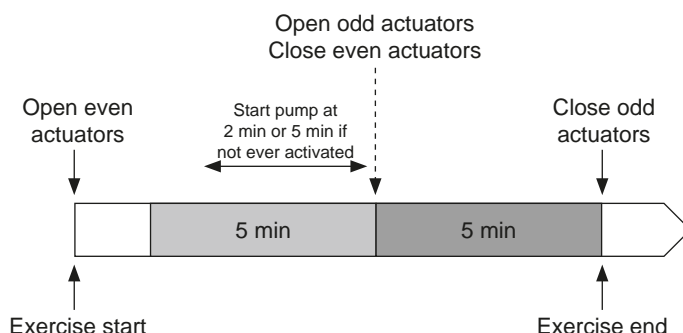

6. OTRAS CARACTERÍSTICAS

6.1 Función antiagarre

La función se activa mediante el DIP6 (véase 3.3). Si las válvulas no están activas durante una semana, se activa un ejercicio completo (actuador + salidas de bomba + demanda de calor/frío enviado al SH-HCM).



6.2 Restablecer

En caso de disfunción, puede ser necesario restablecer la configuración de fábrica del producto. Pulsando  durante 5 segundos, el máster entra en el menú Reset. El LED de la zona 1 empieza a parpadear en rojo, el LED de las zonas restantes empieza a parpadear en verde. A continuación, pulsando simultáneamente en ,  y  hasta conseguir que todos los LED de zona se pongan en rojo, se activa el reset del controlador y el producto se reinicia. Los LED se apagan.

6.3 Solución de problemas

Síntoma	Problemas	Descripción	Solución de problemas
Parpadeo rojo o azul del LED de calor y frío y El LED de la bomba/secadora parpadea en rojo	Detección de seguridad	Se abre el contacto de la entrada de seguridad	Si no utiliza un termostato de seguridad, asegúrese de haber instalado una correa en la entrada del termostato de seguridad. De lo contrario, controle la temperatura de la tubería (demasiado caliente en modo calefacción, demasiado fría en modo refrigeración).
Parpadeo rojo/azul del LED de calor y frío	Problema de radiofrecuencia	La unidad base ha perdido la conexión con un dispositivo de radiofrecuencia que no sea un termostato.	Compruebe la distancia entre los dispositivos. Si el controlador está instalado dentro de una caja metálica, utilice una antena externa situada fuera de la caja metálica. Puede ser necesario un repetidor de radiofrecuencia.
Parpadeo rápido en azul del LED de la bomba/secadora	Problema de configuración de la humedad	Medición NTC en la entrada H&C mientras el DIP8 = OFF. Entrada ON/OFF en la entrada H&C mientras que el DIP8 = ON	Compruebe si el sensor NTC y el ajuste del interruptor DIP
Rojo intermitente en 1 zona	Error de radiofrecuencia con el termostato	La unidad base ha perdido la conexión con el termostato.	Compruebe la distancia entre la unidad base y el termostato. Puede ser necesario un repetidor de radiofrecuencia.
Rojo intermitente en todas las zonas	Error de antena RF	El programador ha perdido todas las conexiones de radiofrecuencia (termostato y otros dispositivos).	Puede ser necesaria una antena externa.

7. CARACTERÍSTICAS TÉCNICAS

7.1 Datos técnicos

	SH-CD6-24, SH-CD6-230, SH-CD10-24, SH-CD10-230
Protección eléctrica	Clase II con tierra funcional
Protección IP	IP30
Temperatura de transporte y almacenamiento	-10 °C a 50 °C (14 °F a 122 °F)
Alimentación	230 V CA ± 10% 50 Hz
Carga máxima de salida (2 salidas)	Relé: 5 A
Actuadores	230 V /24 V NC/NO hasta 2 W
Compatibilidad	SH-AT, SH-DT, SH-DTP, SH-HCM, SH-CU, SH-SM

7.2 Dimensiones y peso

SH-CD6-24 und SH-CD6-230:

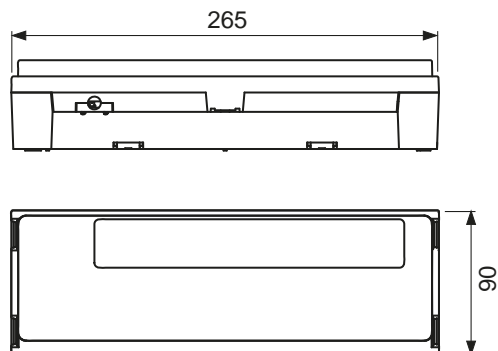

SH-CD10-24 und SH-CD10-v230:

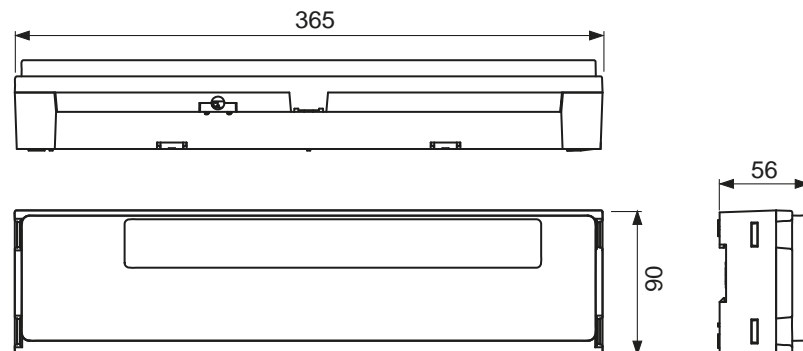

Gewicht: 840 g - SH-CD6
940 g - SH-CD10

8. DIRECTIVAS

Designación	Descripción	Enlace
Directiva de baja tensión (LVD)	La Directiva de Baja Tensión (LVD) (2014/35/UE) garantiza que los equipos eléctricos dentro de ciertos límites de tensión proporcionen un alto nivel de protección a los ciudadanos europeos y se beneficien plenamente del mercado único.	2014/35/UE
Compatibilidad electromagnética (CEM) Directiva 2014/30/UE	La Directiva de Compatibilidad Electromagnética (EMC) 2014/30/UE garantiza que los equipos eléctricos y electrónicos no generen perturbaciones electromagnéticas ni se vean afectados por ellas.	2014/30/UE
Restricción del uso de determinadas sustancias peligrosas (RoHS) 2011/65/UE	Directiva relativa a la restricción del uso de determinados sustancias peligrosas en aparatos eléctricos y electrónicos equipo.	2011/65/EU
Residuos eléctricos & Equipos electrónicos Directiva RAEE	La Directiva RAEE (2012/19/UE) tiene como objetivo reducir la cantidad de residuos de aparatos eléctricos y electrónicos que acaban en los vertederos.	2012/19/EU
Comisión de Diseño Ecológico Reglamento	Requisitos de diseño ecológico para los calefactores locales.	2015/1188
Directiva sobre equipos radioeléctricos (DER) 2014/53/UE	La Directiva de Equipos Radioeléctricos 2014/53/UE (DER) establece un marco regulador para la comercialización de equipos radioeléctricos.	2014/53/EU

Contenuto

1. INFORMAZIONI GENERALI	60
1.1 Avvertenze di sicurezza e istruzioni per l'uso	60
1.2 Applicazione	60
2. PRESENTAZIONE	60
2.1 Funzioni	60
2.2 Contenuto della scatola	61
2.3 Prima installazione	61
3. DESCRIZIONE DEL PRODOTTO	61
3.1 Significato dei colori dei LED	61
3.2 Tasti	61
3.3 Configurazione dei DIP-switch	62
3.4 Chiave USB	62
4. INGRESSI/USCITE	63
4.1 Alimentazione	63
4.2 Ingresso riscaldamento/raffrescamento (H&C)	63
4.3 Uscita della pompa	64
4.4 Contatto per la limitazione della temperatura	64
4.5 Ingresso rilevamento dell'umidità	64
4.6 Attuatori NC/NO	65
4.7 Esterne Antenne	66
5. Configurazione del sistema	66
5.1 Configurazione del sistema senza Unità Centrale	66
5.2 Configurazione del sistema con Unità Centrale	69
5.3 Controllare un deumidificatore per stanza.	69
6. Altre caratteristiche	70
6.1 Funzione Anti-Grip	70
6.2 Reset	70
6.3 Risoluzione dei problemi	71
7. CARATTERISTICHE TECNICHE	71
7.1 Dati tecnici	71
7.2 Dimensioni e peso	72
8. DIRETTIVE	72

1. INFORMAZIONI GENERALI

1.1 Avvertenze di sicurezza e istruzioni per l'uso

Questo dispositivo deve essere installato da un professionista qualificato. Ferma restando l'osservanza di quanto sopra, il produttore si assume la responsabilità del prodotto in conformità alla legislazione vigente.

Quando si opera con il box di collegamento, seguire tutte le istruzioni contenute nel presente manuale di installazione e uso. Eventuali guasti dovuti ad errori di installazione, uso improprio o a scarsa manutenzione sollevano il produttore dalla responsabilità.



Qualsiasi tentativo di riparazione solleva il produttore dalla responsabilità e dall'obbligo di garanzia e sostituzione.

2012/19/UE (direttiva RAEE): I prodotti contrassegnati con questo simbolo non possono essere smaltiti come rifiuti urbani indifferenziati all'interno dell'Unione Europea. Per un corretto riciclaggio, restituire il prodotto al proprio fornitore di fiducia all'acquisto di un prodotto nuovo equivalente, oppure smaltire il prodotto presso i centri di raccolta preposti. Per maggiori informazioni: www.recyclethis.info.

1.2 Applicazione

Il box di collegamento è stato progettato per l'uso in ambienti residenziali, uffici e impianti industriali. Prima dell'uso, verificare che l'installazione sia conforme alle normative vigenti così da garantirne l'uso corretto.

2. PRESENTAZIONE

Il box di collegamento WFC HC RF è stato progettato appositamente per controllare l'impianto di riscaldamento e raffreddamento a pavimento. Consente di collegare facilmente e rapidamente termostati e attuatori. Sono disponibili 4 versioni:

	Versione 230V	Versione a 24 V
6 zone	SH-CD6-230	SH-CD6-24 (richiede un trasformatore esterno 230 V/24 V: SH-ST)
10 zone	SH-CD10-230	SH-CD10-24 (richiede un trasformatore esterno 230 V/24 V: SH-ST)

2.1 Funzioni

Integra molteplici funzioni:

- Montaggio a parete o su guida DIN
- Collegamenti cavi ad innesto antistrappo
- Indicazione di stato a LED e DIP-Switch per la configurazione del dispositivo
- Gestione di 6 o 10 zone con 2 attuatori per zona
- Possibilità di gestire più zone con stesso termostato
- Configurazione di più sistemi
- Ingresso H&C (230 V e segnale libero da tensione)
- Misura della temperatura dell'acqua (sonda non fornita) per il rilevamento dell'umidità
- Uscita pompa o caldaia (230 V e segnale libero da tensione)
- Gestione dell'anti grip
- Contatto per la limitazione della temperatura
- Antenna RF interna, antenna esterna opzionale
- Adatto ad attuatori elettrotermici di tipo NC e NA
- Porta USB per l'aggiornamento del software e la registrazione dei dati

2.2 Contenuto della scatola

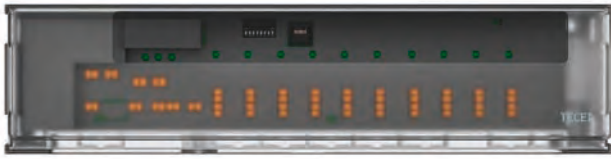

2.3 Prima installazione

Esistono due modi per installare il box di collegamento::

- Montaggio a parete con 2 viti
- Montaggio su guida DIN 35 x 7,5 (DIN EN 60715)

3. DESCRIZIONE DEL PRODOTTO

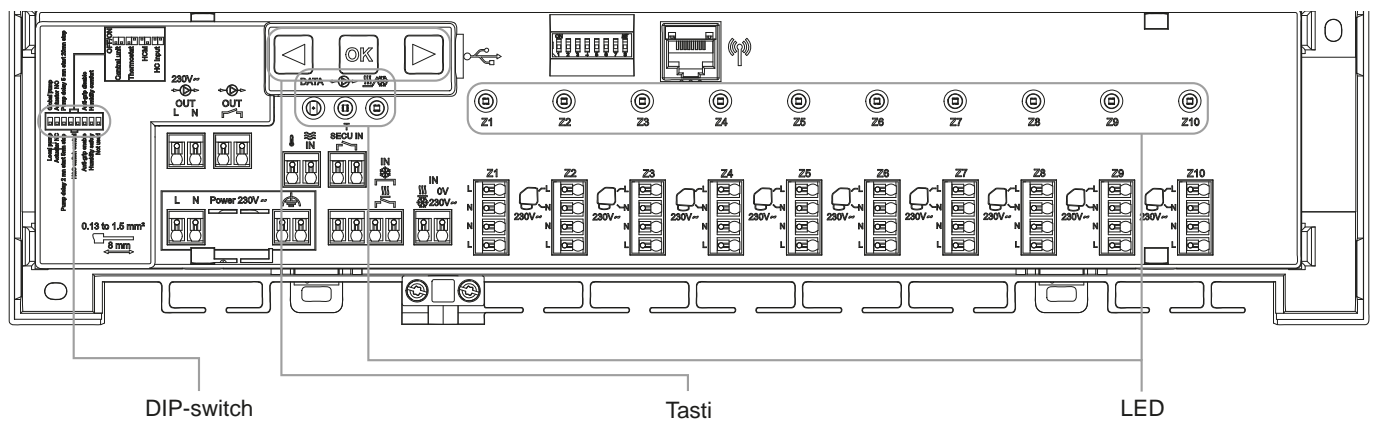

3.1 Significato dei colori dei LED

LED	Significato
LED di calore e raffrescamento (Rosso/Blu)	Fisso rosso = Modalità di riscaldamento Fisso blu = Modalità di raffrescamento Lampeggio rosso (in riscaldamento) o lampeggio blu (in raffrescamento) = Rilevamento di sicurezza Lampeggio rosso/blu = Perdita RF (con SH-CD, SH-HCM, SH-CU). In caso di perdita di RF, il sistema passa in modalità riscaldamento..
LED pompa/deumidificatore (Verde/Blu/Rosso)	Verde fisso = La pompa è attivata Rosso lampeggiante = Errore di sistema (rilevamento di sicurezza / errore del sensore di umidità/...) Lampeggiante blu = Rilevamento dell'umidità globale ampeggio veloce blu = Problema di configurazione dell'umidità.
LED dati (Rosso/Verde)	Verde lampeggiante = Registrazione dati in corso.
LED per zona (Rosso/Verde)	Verde lampeggiante = Trasmissione/ricezione RF Rosso fisso = Richiesta di riscaldamento o raffrescamento nella zona rosso lampeggiante = Errore RF con il termostato Lampeggio rosso su tutte le zone = Errore dell'antenna RF In caso di errore RF con SH-HCM o SH-CU, il sistema passa in modalità riscaldamento.

3.2 Tasti

Sono disponibili 3 tasti capacitivi:



3.3 Configurazione dei DIP-switch

Numero del DIP-switch	Funzione	Valore (impostazione predefinita: OFF)		Configurazione	Descrizione
DIP1	Funzione del box di collegamento	OFF		Pompa locale	Vedi 4.3
		ON		Pompa globale	
DIP2	Tipi di attuatori elettrotermici	OFF		Attuatore NC	Vedi 4.6
		ON		Attuatore NA	
DIP3	Ritardo avvio pompa (per il primo attuatore in richiesta) e ritardo arresto attuatore (per l'ultimo attuatore in richiesta)	OFF		2min/5min	Vedi 4.3 e 4.6
		ON		5min/20min	
DIP4 / DIP5	Gestione modalità riscaldamento / raffreddamento	OFF	OFF	Unità Centrale SH-CU	Vedi 4.2
		OFF	ON	Termostato Master SH-DTF	
		ON	OFF	SH-HCM	
		ON	ON	SH-CD	
DIP6	Anti Grip	OFF		Abilitato	Vedi 6.1
		ON		Disabili	
DIP7	Gestione dell'umidità	OFF		Logica Safety	Vedi 4.5
		ON		Logica Comfort	
DIP8	Sensore di umidità	OFF		Sensore ON/OFF	Vedi 4.5
		ON		Sensore temperatura acqua	

3.4 Chiave USB

La connettività USB consente :

- di aggiornare il software del box di collegamento.
- di registrare i dati per il monitoraggio del sistema (datalog).

Per l'aggiornamento del software, scaricare il file dal sito www.tece.com.eu e caricarlo su una chiavetta USB.

- Inserire la chiavetta USB nel box di collegamento
- Spegner/accendere il box di collegamento
- Durante l'aggiornamento,
 - I LED verdi si accendono da Z1 a Z6/Z10
 - Tutti i LED diventano rossi
 - I LED rossi si spengono da Z6/Z10 a Z1
- Al termine dell'aggiornamento, è possibile rimuovere la chiavetta USB.

La funzione datalog, oltre a registrare i dati su un file ASCII memorizzato sulla chiavetta USB, è utile per la ricerca dei guasti.

Premendo per 5 secondi, il modulo passa al menu Funzioni. Il LED della prima zona lampeggia in rosso (il datalog è abilitato) o in verde (il datalog è disabilitato). È possibile abilitare o disabilitare il datalog premendo .

Premendo a lungo su si esce dal menu delle Funzioni (in alternativa, il modulo esce automaticamente dal menu Funzioni se non rileva alcuna pressione per 10 s).

Viene creato 1 file di log ogni 14 giorni. Nel file viene registrata una registrazione ogni 10 minuti.

4. INGRESSI/USCITE

4.1 Alimentazione

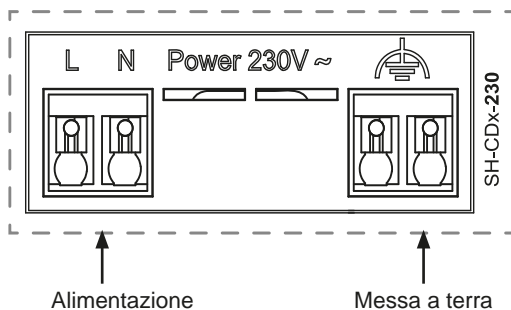

È necessario utilizzare il trasformatore fornito da TECE (4 cavi): SH-ST

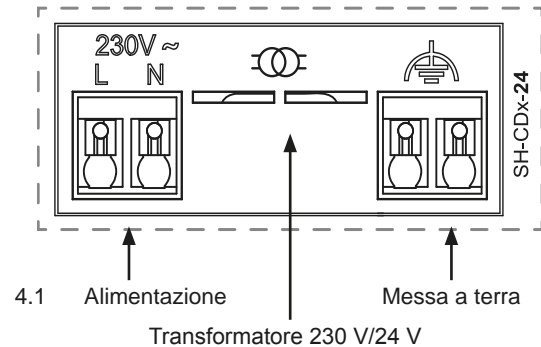

4.2 Ingresso riscaldamento/raffrescamento (H&C)

Scopo:

Questo ingresso consente di commutare la modalità di regolazione del sistema: riscaldamento o raffreddamento.

Fonte del segnale:

- Un interruttore meccanico
- Una pompa di calore
- Un SH-SM accoppiato all'Unità Centrale SH-CU come dispositivo ON/OFF. Questa soluzione consente di ottenere un controllo remoto della modalità H&C dall'applicazione per dispositivi mobili.

Formato del segnale: L'ingresso può essere a contatto libero o in tensione a 230 V.

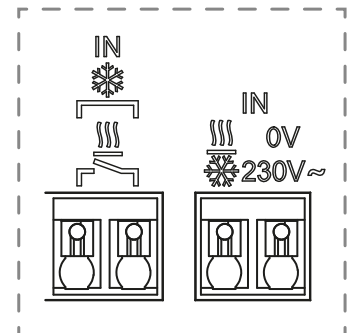

Modalità	Contatto libero	Contatto in tempo reale
Riscaldamento	Aperto	Nessun segnale
Raffrescamento	Chiuso	230 V AC

Solo un dispositivo nel sistema deve essere in grado di selezionare la modalità H&C. Altre possibili fonti di segnale di commutazione H&C (vedere 3.3):

- Unità Centrale (impostare la modalità H&C manuale nel menu di installazione della centrale) DIP4/DIP5 = OFF/OFF.
- Modulo di controllo SH-HCM che integra un ingresso H&C DIP4/DIP5 = ON/OFF.
- Termostato digitale configurato come termostato Master H&C in modalità manuale o automatica (un solo termostato per installazione) DIP4/DIP5 = OFF/ON.

Se nel sistema sono presenti più box di collegamento SH-CD, la modalità H&C deve essere controllata da uno solo; ciò è determinato dall'impostazione di DIP4 / DIP5 (vedere 3.3):

- Senza Unità Centrale, il sistema considera il box di collegamento principale (Main – fare riferimento a 5.1.2) DIP4/DIP5 = ON/ON
- Con Unità Centrale:
 - se il box di collegamento controlla la modalità H&C, DIP4/DIP5 = ON/ON
 - se l'Unità Centrale controlla la modalità H&C, DIP4/DIP5 = OFF/OFF.

DIP4	DIP5	Segnale di commutazione H&C richiesto da
OFF	OFF	Unità Centrale (SH-CU)
OFF	ON	Termostato
ON	OFF	Modulo Heat&Cool (SH-HCM)
ON	ON	Box di collegamento (SH-CD)

4.3 Uscita della pompa

Sono presenti 2 uscite:

- Uscita contatto in tensione (230 V AC)
- Uscita a contatto libero

Queste uscite possono essere utilizzate per l'attivazione:

- Una valvola di zona
- Una pompa di circolazione
- Una caldaia o una pompa di calore

Le 2 uscite vengono attivate quando c'è una richiesta di riscaldamento o di raffreddamento (vedi 3.3).

- Nel box di collegamento se il DIP1 = OFF = locale
- Nel sistema se il DIP1 = ON = globale

Il ritardo tra la richiesta di riscaldamento o raffreddamento e l'attivazione della pompa di circolazione è configurabile (vedi 3.3).

- La pompa si avvia 2 minuti dopo la richiesta di riscaldamento o raffreddamento se il DIP3 = OFF
- La pompa si avvia 5 minuti dopo la richiesta di riscaldamento o raffreddamento se il DIP3 = ON

Lo scopo è quello di considerare la latenza dell'attuatore.

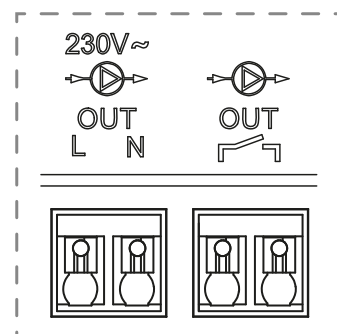

4.4 Contatto per la limitazione della temperatura

Si tratta di un ingresso di sicurezza (contatto libero).

Contatto chiuso	Nessun rilevamento di sicurezza
Contatto aperto	Rilevamento del surriscaldamento o del raffreddamento eccessivo

L'ingresso di sicurezza deve essere utilizzato su un box di collegamento con pompa.

Quando il contatto viene aperto,

- L'uscita della pompa locale viene interrotta (anche se DIP1=ON, cioè pompa globale sul box di collegamento)
- Gli attuatori sono chiusi
- Il LED della pompa/asciugatrice lampeggia in rosso
- Il LED Heat&Cool lampeggia in rosso (in riscaldamento) o in blu (in raffreddamento).
- Se il box di collegamento è di tipo secondario (Sub), la richiesta di riscaldamento o raffreddamento non viene inviata al box di collegamento principale (Main)

È possibile utilizzare un termostato a contatto per la sicurezza termica.

È possibile installare 2 termostati a contatto in serie per proteggersi sia dal surriscaldamento che dal sovra raffreddamento (l'ingresso di sicurezza è valido sia in modalità riscaldamento che raffreddamento).

Il prodotto viene fornito con una fascetta sul connettore.

Si noti che l'uscita pompa del SH-HCM viene attivata quando viene attivata almeno un'uscita pompa del SH-CD multiplo installato nel sistema

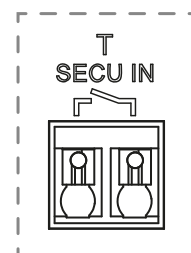

4.5 Ingresso rilevamento dell'umidità

Il box di collegamento dispone di un ingresso per il rilevamento dell'umidità. Può gestire due tipi di segnale in base alla configurazione di DIP8 (vedi 3.3)

- Un sensore di contatto per l'umidità
- Sensore di temperatura dell'acqua (NTC 10 kΩ): Richiede il termostato SH-DTH

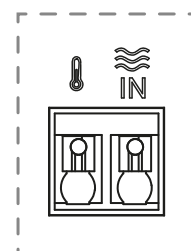

4.5.1 Sensore di umidità a contatto (controllo del punto di rugiada)

DIP8 = OFF

Formato del segnale: l'ingresso è un contatto libero

Nessuna umidità	Contatto aperto
Umidità rilevata	Contatto chiuso

In modalità di raffrescamento, quando viene rilevata l'umidità, il box di collegamento:

- Arresta il segnale della pompa
- Chiude tutti gli attuatori
- Invia gli allarmi di umidità a tutti gli altri SH-CD del sistema.
- Richiede al SH-HCM di abilitare il deumidificatore.

Se il box di collegamento è di tipo secondario (Sub), la richiesta di raffrescamento non viene inviata al box di collegamento principale..

4.5.2 Sensore di temperatura dell'acqua

DIP8 = ON

Il controllo della temperatura dell'acqua può essere utilizzato per due scopi differenti.

Rilevamento e gestione dell'umidità in ambiente

In modalità raffrescamento, per ogni zona, il box calcola il punto di rugiada in base alla temperatura ambiente e all'umidità relativa rilevate da ciascun termostato (è necessario l'utilizzo di termostati con sensore di umidità relativa - SH-DTH). Quando la temperatura dell'acqua raggiunge il di punto di rugiada in una zona, il box di collegamento:

Logica Safety DIP7 = OFF	Logica Comfort DIP7 = ON
Chiude l'attuatore della zona e interrompe la richiesta di raffrescamento della zona.	Mantiene l'attuatore della zona aperto per un'ora, quindi chiude l'attuatore e interrompere la richiesta di raffrescamento nella zona se l'allarme umidità è ancora attivo.

- Abilita il deumidificatore remoto della zona (se presente)
- Richiede al SH-HCM di attivare il deumidificatore globale per almeno 15 minuti e di far scomparire l'allarme se nella zona non è disponibile un deumidificatore remoto.

Se il box di collegamento è secondario (Sub), la richiesta di raffrescamento della zona non viene inviata al box principale.

Rilevamento della modalità di riscaldamento o raffrescamento

Quando DIP4 = ON e DIP5 = ON (controllo modalità H&C = SH-CD) e DIP8 = ON la temperatura dell'acqua viene utilizzata per rilevare automaticamente la modalità H&C.

- Se la temperatura dell'acqua è > 24 °C, il sistema è in modalità riscaldamento.
- Se la temperatura dell'acqua è < 20 °C, il sistema è in modalità di raffrescamento.

Questa funzione è utile quando la pompa di calore passa automaticamente in modalità riscaldamento o raffrescamento e non ha un'uscita per informare il sistema.

- Se la temperatura dell'acqua è controllata dal modulo SH-HCM, il valore rilevato viene trasmesso e gestito tramite il box di controllo SH-CD qualora sprovvisto di sensore di temperatura dell'acqua a bordo.
- Se l'ingresso H&C= modalità raffrescamento, il sistema passa in modalità di raffrescamento indipendentemente dalla temperatura dell'acqua.

4.6 Attuatori NC/NO

Collegare un attuatore NC o NA per ogni connettore

- Attuatori a 230 V per SH-CD 230
- Attuatori a 24 V per SH-CD 24

Il tipo di attuatori è definito da DIP2. È necessario utilizzare lo stesso tipo per tutti gli attuatori. L'attuatore viene attivato non appena una zona richiede riscaldamento o raffrescamento.

Quando la richiesta di riscaldamento o raffrescamento viene soddisfatta, l'attuatore viene chiuso immediatamente, ad eccezione dell'ultimo attuatore aperto nel box di collegamento. In questo caso, il ritardo di chiusura dell'attuatore dipende da DIP3 (vedere 3.3)

- se DIP3=OFF, il sistema attende 5min prima di chiudere l'ultimo attuatore
- se DIP3=ON, il sistema attende 20min prima di chiudere l'ultimo attuatore

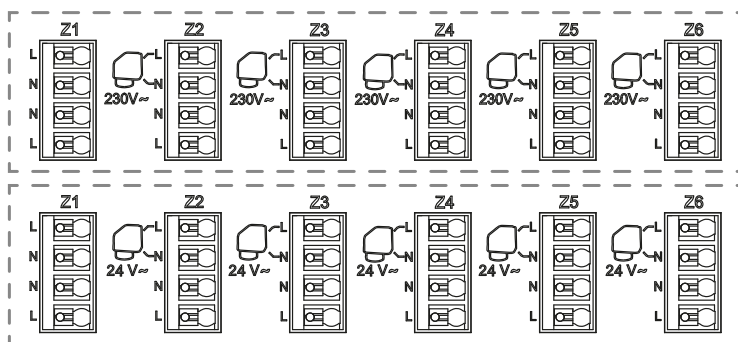

Spiegazione: Molte pompe di calore hanno un tempo di ritardo spegnimento integrato (per evitare ripetuti spegnimenti/accensioni). In questo caso, la pompa di calore continua a funzionare per "X" minuti oltre il tempo di spegnimento effettivo. È importante mantenere aperto almeno un circuito, a meno che l'installazione non preveda un serbatoio tampone, un interruttore idraulico o un bypass.

4.7 Esterne Antenne

Il box di collegamento incorpora un'antenna interna. Se necessario, è possibile collegare un'antenna esterna (accessorio opzionale) per migliorare la comunicazione RF. Potrebbe essere utile se il box di collegamento è installato all'interno di una scatola metallica. In questo caso, è necessario installare l'antenna esterna al di fuori della scatola metallica.

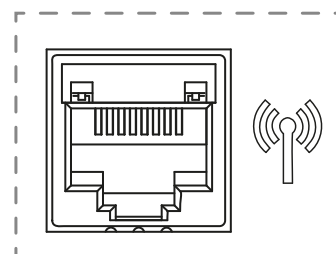

Rispettare lo schema di montaggio per ottimizzare la sensibilità ed evitare malfunzionamenti.

L'antenna deve essere installata:

- fuori dalla scatola metallica
- in posizione verticale e ad almeno 50 cm da parti metalliche

Se si dispone di più antenne (più box di collegamento), queste devono essere posizionate a una distanza minima di 80 cm l'una dall'altra.

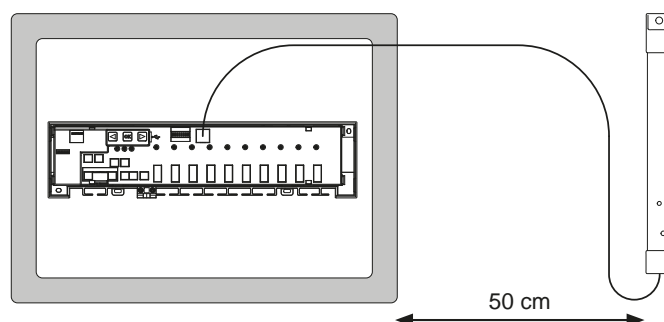





5. Configurazione del sistema

5.1 Configurazione del sistema senza Unità Centrale

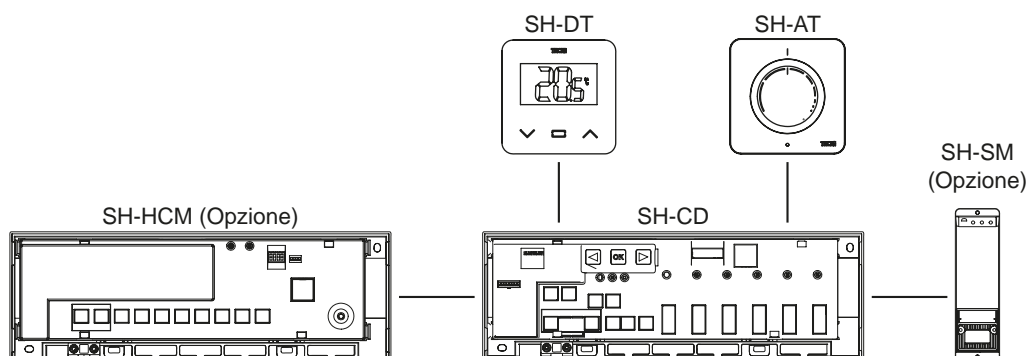
5.1.1 Installazione indipendente

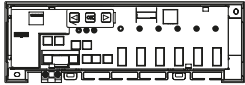
Un solo box di collegamento senza interconnessione

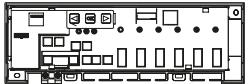
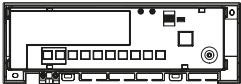
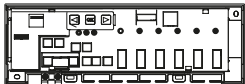

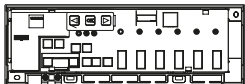
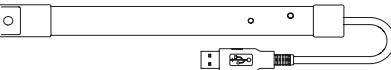
Dispositivo 1	Dispositivo 2	Note
 <p>Premendo OK per 5 secondi, il box di collegamento passa in modalità di accoppiamento RF.</p> <p>Selezionare con ◀ o ▶ la zona 1 (il LED lampeggia in rosso), premere OK per accedere alla modalità di accoppiamento con il termostato. Il LED della prima zona lampeggia verde.</p> <p>Dare OK per selezionare la zona da accoppiare. Spostando il LED verde lampeggiante con ◀ o ▶ è possibile selezionare più zone. Selezionare/deselezionare la zona premendo OK. La zona selezionata è fissa in rosso. L'indicatore di posizione continua a lampeggiare in verde.</p> <p>LED di colore verde fisso indica che la zona è già stata accoppiata (*).</p>	 <p>Termostati:</p> <p>Impostare il prodotto in modalità di accoppiamento RF (fare riferimento al relativo manuale di istruzioni).</p>	<p>Al termine del processo di l'accoppiamento RF, i LED delle zone selezionate sul SH-CD si spengono ed i termostati escono dalla modalità di accoppiamento.</p> <p>* ATTENZIONE Per accoppiare un altro termostato, è necessario inserire/avviare nuovamente la modalità di accoppiamento con il termostato e ripetere la procedura.</p> <p>Per forzare l'uscita dalla modalità di accoppiamento premere a lungo ◀</p>
 <p>Premendo OK per 5 secondi, il box di collegamento passa al menu di accoppiamento RF.</p> <p>Selezionare con ◀ o ▶ la zona 3 (il LED lampeggia in rosso), premere OK per accedere alla modalità di accoppiamento con un dispositivo slave.</p> <p>Tutti i LED lampeggiano in verde.</p>	 <p>Modulo SH-HCM:</p> <p>Impostare il dispositivo in modalità di accoppiamento RF. Premere il pulsante per 10 secondi.</p> <p>Per ulteriori informazioni, consultare il manuale del relativo dispositivo</p>	<p>Al termine del processo di l'accoppiamento RF, i LED del SH-CD e il SH-HCM si spengono, i dispositivi tornano nella normale modalità di funzionamento.</p> <p>Per forzare l'uscita dalla modalità di accoppiamento premere a lungo ◀</p> <p>NOTA: è possibile installare un solo modulo SH-HCM per impianto.</p>
 <p>Premendo OK per 5 secondi, il box di collegamento passa al menu di accoppiamento RF.</p> <p>Selezionare con ◀ o ▶ la zona 3 (il LED lampeggia in rosso), premere OK per accedere alla modalità di accoppiamento con un dispositivo slave.</p> <p>Tutti i LED lampeggiano in verde.</p>	 <p>Ricevitore:</p> <p>Premere per 5 secondi il pulsante del SH-SM per avviare la modalità di accoppiamento RF. .</p> <p>Per ulteriori informazioni, consultare il manuale del dispositivo.</p>	<p>Al termine del collegamento, il WR02 RF esce dalla modalità di accoppiamento.</p> <p>SH-CD torna in modalità di accoppiamento.</p> <p>Per forzare l'uscita dalla modalità di accoppiamento premere a lungo ◀.</p>
 <p>Premendo OK per 5 secondi, il box di collegamento passa al menu di accoppiamento RF.</p> <p>Selezionare con ◀ o ▶ la zona 3 (il LED lampeggia in rosso), premere OK per accedere alla modalità di accoppiamento con un dispositivo slave.</p> <p>Tutti i LED lampeggiano in verde.</p>	 <p>Antenna ripetizione segnale RF:</p> <p>Premere per 3 secondi il pulsante del SH-R per avviare la modalità accoppiamento RF.</p> <p>Per ulteriori informazioni, consultare il manuale del dispositivo.</p>	<p>Al termine del collegamento, il SH-R esce dalla modalità di accoppiamento.</p> <p>SH-CD torna in modalità di accoppiamento.</p> <p>Per forzare l'uscita dalla modalità di accoppiamento premere a lungo ◀.</p>

5.1.2 Installazione di più box di collegamento

Se nell'impianto ci sono più collettori, è possibile installare più box di collegamento interconnessi, nel dettaglio 1 box principale (Main SH-CD) e fino a 3 box secondari (Sub SH-CD).

Il box di collegamento principale centralizza le informazioni per i box secondari. Se si prevede di utilizzare anche il modulo SH-HCM, questo dovrà essere abbinato al box principale (Main):

- Il box principale trasmette la modalità di riscaldamento e raffreddamento ai box secondari. Queste informazioni possono provenire dal SH-HCM o da un termostato Master Digital in base ai DIP4 e DIP5 (Vedere 3.3)
- Il box principale è in grado di gestire il segnale della pompa dell'intero impianto in base al DIP1 (vedere il capitolo 3). 3.3))

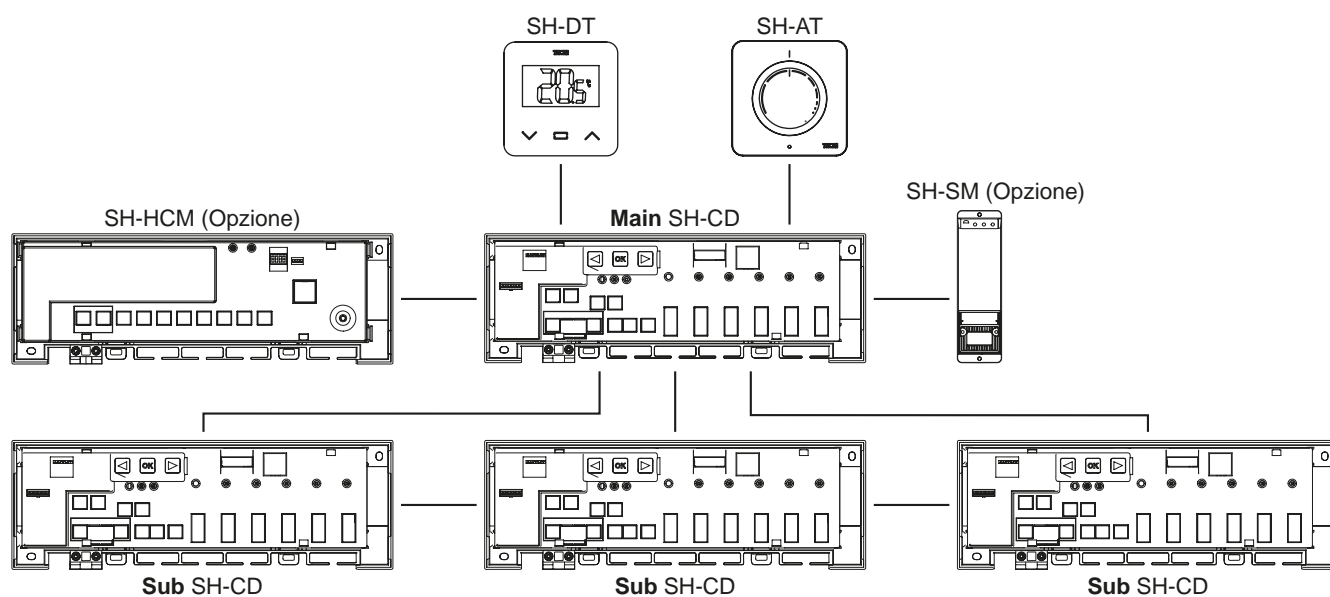

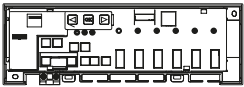
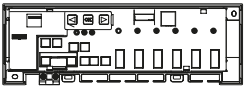
Dispositivo 1: box principale	Dispositivo 2: box secondario	Note
Innanzitutto, tutti i termostati radio devono essere abbinati al rispettivo box di collegamento SH-CD! Vedere 5.1.1		
 <p>DPremendo OK per 5 secondi, il box di collegamento passa al menu di accoppiamento RF.</p> <p>Selezionare con ◀ o ▶ la zona 3 (il LED lampeggia in rosso), premere OK per accedere alla modalità di accoppiamento con un dispositivo slave.</p> <p>Tutti i LED lampeggiano in verde.</p>	 <p>Premendo OK per 5 secondi, il box di collegamento passa al menu di accoppiamento RF.</p> <p>Selezionare con ◀ o ▶ la zona 2 (il LED lampeggia in rosso), premere OK per accedere alla modalità di accoppiamento con un dispositivo master.</p> <p>Tutti i LED lampeggiano in rosso.</p>	<p>Al termine dell'accoppiamento RF, entrambi i SH-CD tornano in modalità di accoppiamento.</p> <p>Per forzare l'uscita dalla modalità di accoppiamento premere a lungo ◀.</p>

5.2 Configurazione del sistema con Unità Centrale

L'Unità Centrale centralizza la comunicazione tra i box di collegamento.

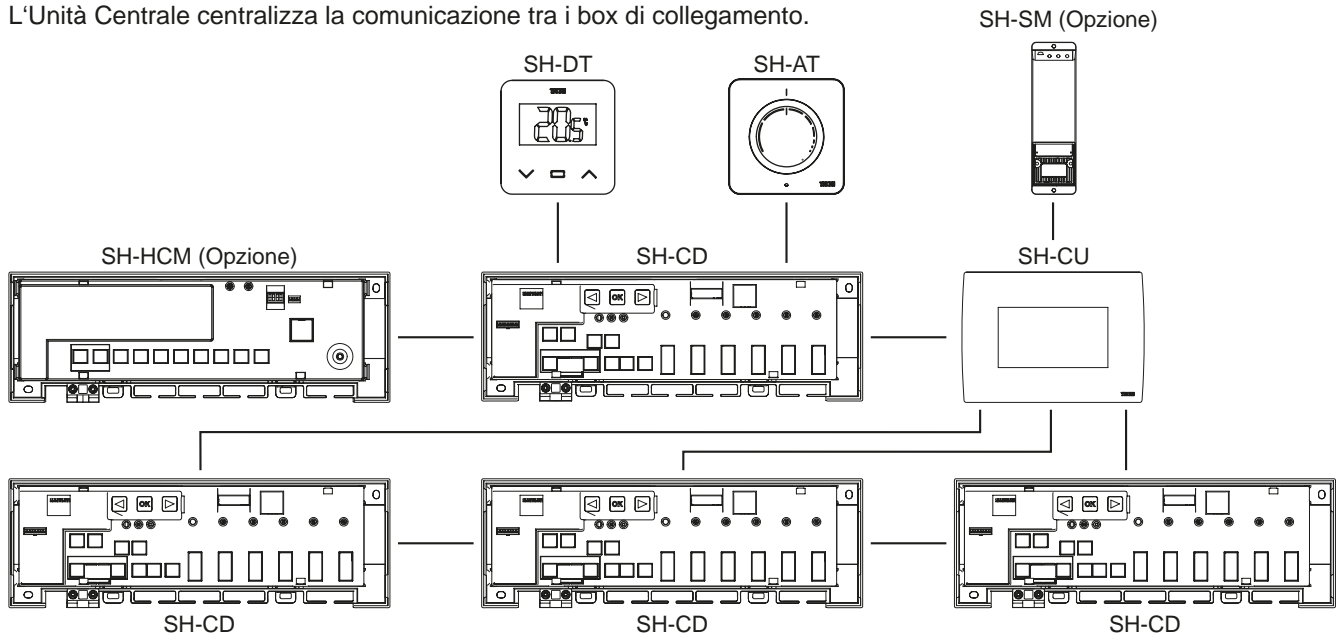

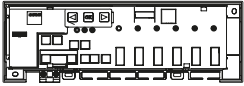
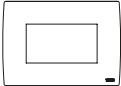
Dispositiv 1: SH-CD	Dispositiv 2: SH-CU	Note
Innanzitutto, tutti i termostati radio devono essere abbinati al rispettivo box di collegamento RF WFC-03 HC! Vedere 5.1.1		
 <p>Premendo OK per 5 secondi, il box di collegamento passa al menu di accoppiamento RF.</p> <p>Selezionare con ◀ o ▶ la zona 2 (il LED lampeggia in rosso), premere OK per accedere alla modalità di accoppiamento con un dispositivo master.</p> <p>Tutti i LED lampeggiano in rosso.</p>	 <p>Mettere il dispositivo in modalità di accoppiamento RF.</p> <p>Selezionare una stanza (Stanza 1).</p> <p>Quando si accoppia un SH-CD con SH-CU, viene generata una stanza per ogni termostato wireless.</p> <p>Pertanto, le stanze non devono essere create in precedenza nell'Unità Centrale.</p>	<p>Wenn die Verbindung hergestellt ist, verlassen sowohl SH-CD als auch SH-CU den Kopplungsmodus. Verlassen des RF-Kopplungsmodus: Drücken Sie lange auf ◀.</p>

5.3 Controllare un deumidificatore per stanza.

Esistono due modi per rilevare l'umidità:

- Con sensore/controllo esterno, utilizzando l'ingresso rilevamento umidità (Vedere 4.5) del box di collegamento.
- Con un termostato ambiente con sensore di umidità relativa integrato (SH-DTH)

Quando viene rilevata l'umidità, è possibile attivare il deumidificatore in due modi:

- Un deumidificatore globale viene attivato dal SH-HCM (se la funzione è attivata – consultare il manuale del dispositivo)
- Un deumidificatore viene attivato nella stanza in cui viene rilevata l'umidità.

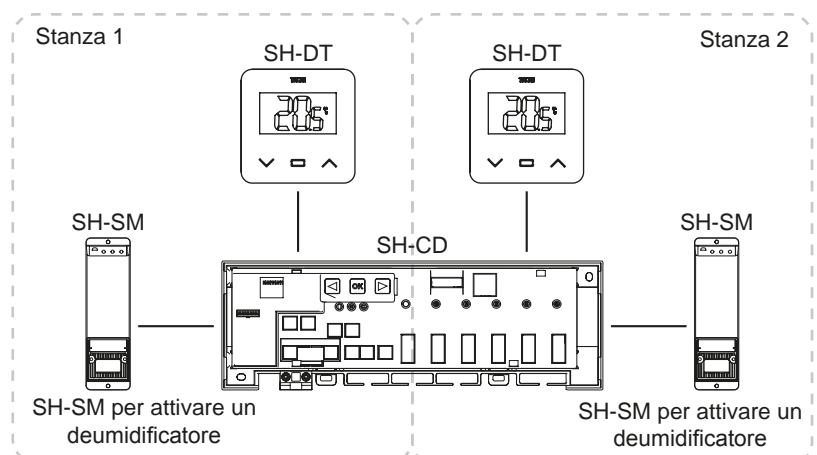

In questo caso, è necessario accoppiare un ricevitore SH-HCM su ciascuna zona del programmatore per attivare un deumidificatore.

Dispositivo 1: SH-CD	Dispositivo 2: SH-SM	Osservazioni
<p>Premendo OK per 5 secondi, il box di collegamento passa al menu di accoppiamento RF.</p> <p>Selezionare con ◀ o ▶ la zona 4 (il LED lampeggia in rosso), premere OK per accedere alla modalità di accoppiamento del deumidificatore.</p> <p>Scegliere le zone con ◀ o ▶.</p> <p>Le zone sono definite da canali di termostati accoppiati.</p> <p>Ad esempio: TH1 = Z1, TH2 = Z2+Z3 e TH3 = Z4+Z5+Z6. La navigazione propone 3 zone per accoppiare un deumidificatore su (Z1), (Z2+Z3) e (Z4+Z5+Z6).</p> <p>Selezionare/deselezionare la zona con OK a (È possibile selezionare una sola zona per deumidificatore). Il cursore lampeggia in verde.</p> <p>LED della zona selezionata lampeggia in rosso e verde. LED di colore verde fisso indica che la zona è già stata accoppiata</p> <p>(Per rimuovere un deumidificatore, selezionare una zona in verde fisso, quindi premere contemporaneamente f ◀ e ▶, sino a che il LED lampeggia in verde).</p>	 <p>Premere per 5 secondi il pulsante del SH-SMF per avviare la modalità di accoppiamento RF.</p> <p>Per ulteriori informazioni, consultare il manuale del dispositivo.</p>	<p>Al termine del collegamento, il SH-SM esce dalla modalità di accoppiamento.</p> <p>SH-CD torna in modalità di accoppiamento.</p> <p>Per forzare l'uscita dalla modalità di accoppiamento premere a lungo ◀.</p>

6. Altre caratteristiche

6.1 Funzione Anti-Grip

L'abilitazione della funzione avviene tramite DIP6 (vedi 3.3). Se le valvole non sono attive per il periodo di una settimana, viene attivato un ciclo di funzionamento completo (attuatore + uscite della pompa + richiesta di calore/raffrescamento inviata al SH-HCM).

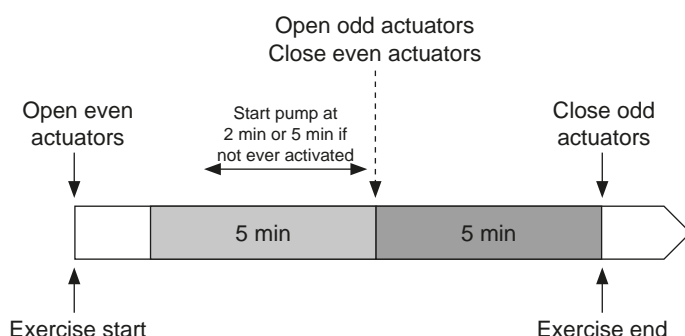

6.2 Reset

In caso di malfunzionamento, potrebbe essere necessario ripristinare le impostazioni di fabbrica del prodotto. Premendo **▶** per 5 secondi, il box di collegamento passa al menu Reset: LED della zona 1 lampeggia rosso, i LED delle altre zone lampeggiano verde.

Premendo poi contemporaneamente su **◀**, **OK** e **▶** fino a far diventare rossi i LED di tutte le zone si attiva il reset del box di collegamento. Al termine del processo tutti i LED si spengono ed il prodotto si riavvia.

6.3 Risoluzione dei problemi

Sintomo	Problemi	Descrizione	Risoluzione dei problemi
Lampeggio rosso o blu dei LED di modalità riscaldamento/raffrescamento e lampeggio rosso del LED attivazione pompa/deumidificatore	Rilevamento della sicurezza	Il contatto dell'ingresso di sicurezza è aperto	Se non si utilizza un termostato di sicurezza, assicurarsi di aver ponticellato l'ingresso del termostato di sicurezza. In caso contrario, controllare la temperatura del tubo (troppo caldo in modalità riscaldamento, troppo freddo in modalità raffrescamento)..
Lampeggio rosso/blu del LED di modalità riscaldamento/raffrescamento	Problema RF	Il box di collegamento ha perso la connessione con un dispositivo RF diverso dal termostato.	Verificare la distanza tra i dispositivi. Se il box di collegamento è installato all'interno di una scatola metallica, collegare l'antenna esterna (accessorio opzionale) ed installarla all'esterno della scatola metallica. Potrebbe essere necessario un anche ripetitore RF..
Lampeggio blu veloce del LED attivazione pompa/deumidificatore	Problema di configurazione dell'umidità	Sonda NTC collegata all'ingresso rilevamento umidità nonostante DIP8 = OFF. Ingresso ON/OFF su ingresso rilevamento umidità nonostante DIP8 = ON	Controllare corretto collegamento e funzionamento del sensore NTC nonché corretta l'impostazione del DIP8
Rosso lampeggiante del LED zona 1	Errore RF con il termostato	Il box di collegamento ha perso il collegamento con il termostato.	Controllare la distanza tra il box di collegamento e il termostato. Potrebbe essere necessario un ripetitore RF.
Rosso lampeggiante su tutte le zone	Errore dell'antenna RF	Il box di collegamento ha perso tutte le connessioni RF (termostato e altri dispositivi).	Potrebbe essere necessario installare l'antenna esterna (accessorio opzionale)

7. CARATTERISTICHE TECNICHE

7.1 Dati tecnici

	SH-CD6-24, SH-CD6-230, SH-CD10-24, SH-CD10-230
Protezione elettrica	Classe II con terra funzionale
Protezione IP	IP30
Temperatura di spedizione e di magazzinaggio	-10 °C à 50 °C (14 °F à 122 °F)
Alimentazione	230 V CA ± 10 % 50 Hz
Carico massimo in uscita (2 uscite)	Relè: 5 A
Attuatori	230 V /24 V NC/NA fino a 2 W
Compatibilità	SH-AT, SH-DT, SH-DTP, SH-HCM, SH-CU, SH-SM

7.2 imensioni e peso

SH-CD6-24 e SH-CD6-230:

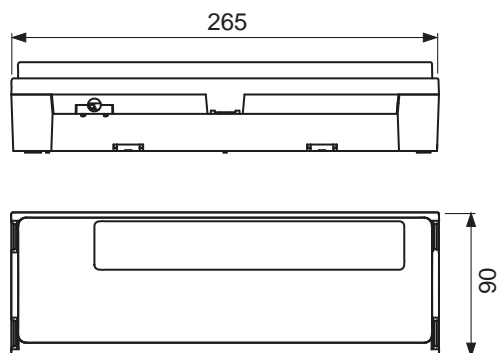

SH-CD10-24 e SH-CD10-v230:

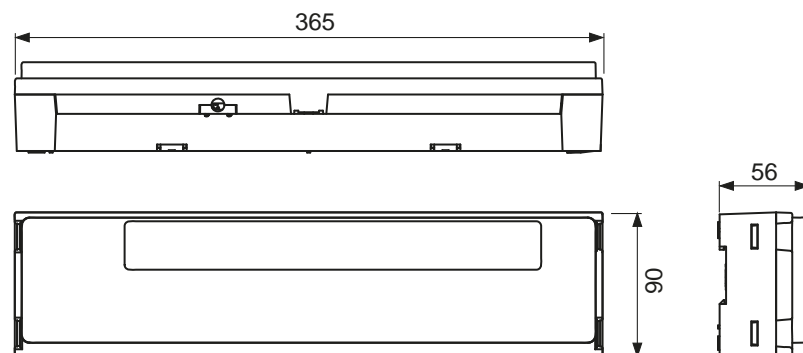

Peso: 840 g - SH-CD6
940 g - SH-CD10

8. DIRETTIVE

Designazione	Descrizione	Link
Direttiva bassa tensione (LVD) 2014/35/EU	La Direttiva bassa tensione (LVD) (2014/35/UE) assicura che entro determinati limiti di tensione le apparecchiature elettriche prevedano un livello elevato di protezione per i cittadini europei e sfrutta appieno i vantaggi del mercato unico europeo.	2014/35/EU
Compatibilità elettromagnetica (EMC) Direttiva 2014/30/EU	La Direttiva compatibilità elettromagnetica (EMC) 2014/30/UE assicura che le apparecchiature elettriche ed elettroniche non generino o subiscano interferenze elettromagnetiche.	2014/30/EU
Direttiva RoHS 2011/65/EU sulla restrizione all'uso di determinate sostanze pericolose	Direttiva sulla restrizione all'uso di determinate sostanze pericolose nelle apparecchiature elettriche ed elettroniche.	2011/65/EU
Direttiva RAEE sui rifiuti di apparecchiature elettriche ed elettroniche	La Direttiva RAEE (2012/19/UE) mira a ridurre la quantità di rifiuti di apparecchiature elettriche ed elettroniche conferite in discarica.	2012/19/EU
Regolamento (EU) 2015/1188 della Commissione	Specifiche per la progettazione ecocompatibile degli apparecchi per il riscaldamento d'ambiente locale.	2015/1188
Direttiva apparecchiature radio (RED) 2014/53/EU	La Direttiva relativa alle apparecchiature radio 2014/53/UE (RED) stabilisce un quadro normativo concernente la messa a disposizione delle apparecchiature radio sul mercato.	2014/53/EU

Inhoud

1. ALGEMENE INFORMATIE	74
1.1 ALGEMENE INFORMATIE	74
1.2 Toepassing	74
2. PRESENTATIE	74
2.1 Eigenschappen	74
2.2 Inhoud van de verpakkin	75
2.3 Eerstmalige Installation	75
3. PRODUCTOMSCHRIJVING	75
3.1 LED kleur betekenis	75
3.2 Toetsen	75
3.3 DIP-schakelaarconfiguratie	76
3.4 USB-stick	76
4. INGANGEN/UITGANGEN	77
4.1 Voeding	77
4.2 Ingang verwarming/koeling (H&C)	77
4.3 Pompvermogen	78
4.4 Contact voor maximaal thermostaat	78
4.5 Ingang voor vochtigheidsdetectie	78
4.6 NC/NO actuators	79
4.7 Externe antenne	80
5. Systeemconfiguratie	80
5.1 Systeemconfiguratie zonder centrale	80
5.2 Systeemconfiguratie met centrale eenheid	83
5.3 Regel een ontvochtiger per ruimte	83
6. Andere kenmerken	84
6.1 Anti Grip Eigenschap	84
6.2 Reset	84
6.3 Problemen oplossen	85
7. TECHNISCHE KENMERKEN	85
7.1 Technische gegevens	85
7.2 Afmetingen en gewicht	86
8. RICHTLIJNEN	86

1. ALGEMENE INFORMATIE

1.1 ALGEMENE INFORMATIE

Dit product dient bij voorkeur door een gekwalificeerde vakman te worden geïnstalleerd. Met inachtneming van de bovenstaande bepalingen neemt de fabrikant de aansprakelijkheid voor de apparatuur op zich zoals voorzien in de wettelijke bepalingen.

Alle instructies in deze installatie- en bedieningshandleiding moeten in acht worden genomen bij het werken met de regelaar. Storage's door verkeerde installatie, verkeerd gebruik of slecht onderhoud maken de aansprakelijkheid van de fabrikant ongedaan.



Bij elke poging tot reparatie vervalt de verantwoordelijkheid en de verplichting tot garantie en vervanging door de fabrikant. 2012/19/EU (WEEE-richtlijn): Producten met dit symbool mogen in de Europese Unie niet als ongesorteerd huishoudelijk afval worden afgevoerd. Voor correcte recycling dient u dit product bij aankoop van gelijkwaardige nieuwe apparatuur in te leveren bij uw plaatselijke leverancier, of af te geven bij aangewezen inzamelpunten. Zie voor meer informatie: www.recyclethis.info.

1.2 Toepassing

De regelaar is ontworpen voor gebruik in woonruimten, kantoorruimten en industriële installaties. Controleer vóór gebruik of de installatie voldoet aan de bestaande voorschriften om een juist gebruik van de installatie te waarborgen.

2. PRESENTATIE

De verbindingsaansluitmodule SH-CD is speciaal ontworpen voor de regeling van uw vloerverwarming en -koeling. Het maakt eenvoudige en snelle aansluiting van thermostaten en actuators mogelijk. Er zijn 4 versies beschikbaar:

	230 V versie	24 V versie
6 zones	SH-CD6-230	SH-CD6-24 (externe 230 V / 24 V transformator vereist: SH-ST)
10 zones	SH-CD10-230	SH-CD10-24 (externe 230 V / 24 V transformator vereist: SH-ST)

2.1 Eigenschappen

Het heeft meerdere functies geïntegreerd:

- Wandmontage of montage op DIN-rail.
- Push-fit kabelverbindingen met trekcontlasting.
- LED-statusindicatie en DIP-schakelaar voor apparaatinstelling.
- Regeling van 6 of 10 zones met 2 actuators per zone.
- Eenvoudig samenvoegen van de zones op dezelfde thermostaat.
- Configuratie van meerdere systemen.
- H&C ingang (230 V en voltvrij signaal).
- Watertemperatuurmeting (sonde niet meegeleverd) voor vochtigheidsdetectie.
- Pomp- of keteluitgang (230 V en voltvrij signaal).
- Anti-Grip regeling van actuators en pomp.
- Contact voor maximaal thermostaat.
- Interne RF-antenne, optionele externe antenne.
- Werkt met NC en NO actuators.
- USB-connectiviteit voor software-update en gegevenslogboek

2.2 Inhoud van de verpakkin

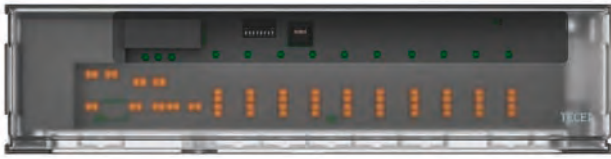

2.3 Eerstmalige Installation

Er zijn 2 manieren om de aansluitmodule te installeren:

- Wandmontage met 2 schroeven.
- Gemonteerd op een DIN-rail 35 x 7,5 (DIN EN 60715)

3. PRODUCTOMSCHRIJVING

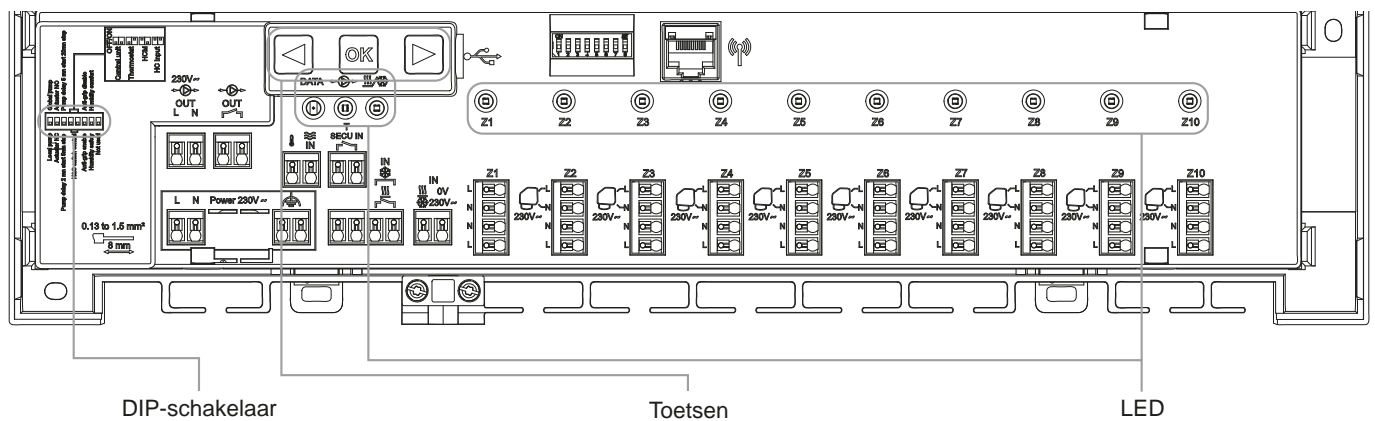

3.1 LED kleur betekenis

LED	Betekenis
Verwarmen en koelen LED (Rood/Blauw)	Fix Rood = Verwarmingsmodus. Fix Blauw = Koelmodus. Rood knipperen (in verwarming) of blauw knipperen (in koeling) = alarm. Rood / Blauw knipperen = RF-verlies (met SH-CD, SH-HCM, SH-CU, interne antenne). In geval van RF-verlies schakelt het systeem over naar de verwarmingsmodus..
Pomp/Droger LED (Groen/Blauw/Rood)	Fix Groen = Pomp is geactiveerd. Rood knipperend = Systeemfout (alarm / fout vochtigheidssensor/...). Blauw knipperen = Globale vochtigheidsdetectie. Rood knipperen = Probleem met de vochtigheidsconfiguratie.
Gegevens LED (Rood/Groen)	Groen knipperend = Lopend gegevenslogboek
LED per zone (Rood/Groen)	Groen knipperen = RF transmissie/ontvangst. Fix Rood = Verwarmings- of koelvraag in de zone. Rood knipperen = RF-fout met de thermostaat. Rood knipperen op alle zones = RF antenne fout. In geval van een RF-fout met SH-HCM of SH-CU, schakelt het systeem over naar de verwarmingsmodus.

3.2 Toetsen

Er zijn 3 capacitieve toetsen beschikbaar:



3.3 DIP-schakelaarconfiguratie

DIP-schakelaar nummer	Functie	Waarde (standaard: OFF)		Configuratie	Beschrijving
DIP1	Controlefunctie	OFF		Lokale pomp	Zie 4.3
		ON		Globale pomp	
DIP2	Typen aandrijvingen	OFF		NC-aandrijving	Zie 4.6
		ON		GEEN aandrijving	
DIP3	Pompstartvertraging (voor de eerste actuator in vraag) en actuatorstopvertraging (voor de laatste actuator in vraag)	OFF		2 min/5 min	Zie 4.3 en 4.6
		ON		5 min/20 min	
DIP4 / DIP5	H&C schakelaarcontrole	OFF	OFF	Centrale eenheid SH-CU	Zie 4.2
		OFF	ON	Hoofdthermostaat SH-DT	
		ON	OFF	SH-HCM	
		ON	ON	SH-CD	
DIP6	Anti Grip	OFF		Ingeschakeld	Zie 6.1
		ON		Uitgeschakeld	
DIP7	Beheer van de vochtigheid	OFF		Veiligheidsaanpak	Zie 4.5
		ON		Comfort benadering	
DIP8	Vochtigheidssensor	OFF		ON/OFF sensor	Zie 4.5
		ON		Pijptemperatuursensor	

3.4 USB-stick

USB-connectiviteit:

- Om de software van de controller bij te werken.
- Om gegevens op te nemen voor systeembewaking (datalog).

Zie voor de software-update www.tece.com voor het verkrijgen van het bestand, zet het bestand op een USB-stick.

- Plaats de USB-stick op de controller
- De regelaar UIT/AAN zetten
- Tijdens de update,
 - Groene LEDS zijn ingeschakeld van Z1 tot Z6/Z10
 - Alle LEDS worden rood
 - Rode LEDS zijn uit van Z6/Z10 naar Z1
- Na de update kunt u de USB-stick verwijderen

Voor probleemoplossing is datalog nuttig om gegevens op te slaan in een ASCII-bestand dat is opgeslagen op de USB-dongle.

Door 5 seconden op te drukken, gaat de master in het functiemenu. De LED van de eerste zone knippert rood (datalog is ingeschakeld) of groen (datalog is uitgeschakeld). U kunt de datalog in- of uitschakelen door te klikken op .

Door lang te drukken op kan het functiemenu worden verlaten (anders is er een time-out van 10s voordat het functiemenu automatisch wordt verlaten).

Elke 14 dagen wordt een logbestand aangemaakt. In het bestand wordt elke 10min een record gemaakt.

4. INGANGEN/UITGANGEN

4.1 Voeding

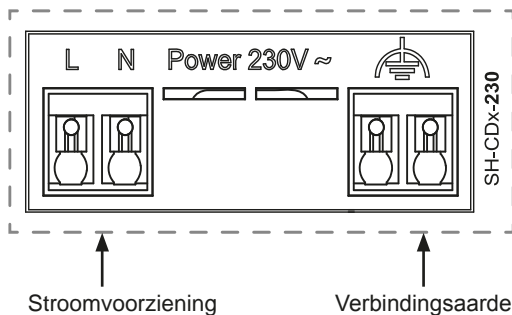

Vereist het gebruik van een door TECE geleverde transformator (4 kabels): SH-ST

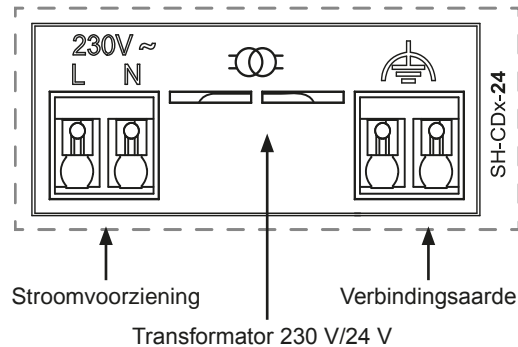

4.2 Ingang verwarming/koeling (H&C)

Doel:

Met deze ingang kan de regelmodus voor het systeem worden omgeschakeld: Verwarmen of koelen.

Bron van het signaal:

- Een mechanische schakelaar.
- Een warmtepomp.
- Een SH-SM gekoppeld aan de SH-CU centrale als AAN/UIT apparaat. Deze oplossing maakt een omschakeling van de H/C modus op afstand mogelijk.

Aard van het signaal: De ingang kan Potentiaal vrij zijn of onder spanning staan 230 V.

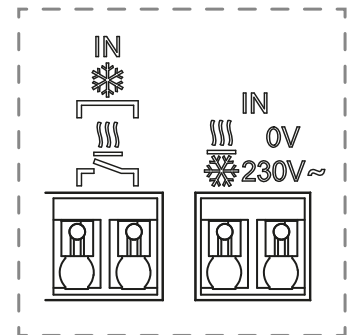

Modus	Vrij contact	Live contact
Verwarming	Geopend	Geen signaal.
Koeling	Gesloten	230 V AC

Slechts één apparaat in het systeem mag de H&C-modus kunnen bepalen. Andere mogelijke H&C-schakelsignaalbron (Zie 3.3)

- Centrale (stel selectie H&C-modus in het installatiemenu van de centrale in), DIP4/DIP5 = OFF/OFF.
- SH-HCM met een H&C-ingang, DIP4/DIP5 = ON/OFF.
- Digitale thermostaat geconfigureerd als een Master H&C thermostaat in handmatige of automatische modus (slechts één thermostaat per installatie), DIP4/DIP5 = OFF/ON.

Als u meerdere Aansluitmodules SH-CD in het systeem hebt, moet de H&C-modus door slechts één regelaar worden bepaald:

- Zonder centrale beschouwt het systeem de ingestelde regelaar als Hoofd SH-CD (zie 5.1.2), DIP4/DIP5 = ON/ON.
- Met centrale:
 - Als de regelaar de H&C modus regelt, DIP4/DIP5 = ON/ON.
 - Als de centrale de H&C-modus regelt. DIP4/DIP5 = OFF/OFF.

DIP4	DIP5	Omschakelsignaal H&C verzoek door
OFF	OFF	Centrale eenheid (SH-CU)
OFF	ON	Thermostaat
ON	OFF	Heat&cool module (SH-HCM)
ON	ON	Aansluitmodule (SH-CD)

4.3 Pompvermogen

Er zijn 2 uitgangen:

- Uitgang onder spanning (230 V AC)
- Potentiaalvrije uitgang Deze uitgangen kunnen worden gebruikt voor het aansturen van:
 - Een zoneklep
 - Een pomp
 - Een cv-ketel of warmtepomp

De 2 uitgangen worden geactiveerd wanneer er vraag is naar verwarming of koeling (Zie 3.3):

- In de besturing als DIP-schakelaar 1 = OFF = lokaal.
- In het systeem als DIP-schakelaar 1 = ON = globaal.

De vertraging tussen de vraag naar verwarming of koeling en de activering van de pomp is configureerbaar (Zie 3.3):

- Pomp start 2 minuten na verwarmings- of koelvraag als DIP-schakelaar 3 = OFF.
- Pomp start 5 minuten na verwarmings- of koelvraag als DIP-schakelaar 3 = ON.

Het doel is rekening te houden met de snelheid van de actuator.

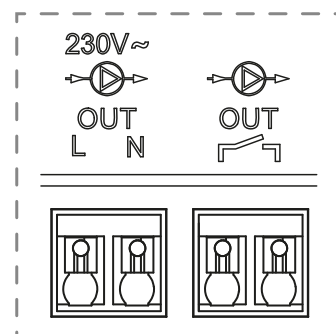

4.4 Contact voor maximaal thermostaat

Dit is een beveiligingsingang (Vrij contact).

Gesloten contact	Geopend Contact
Geen veiligheidsdetectie	Detectie van oververhitting of overkoeling

De beveiligingsingang moet worden gebruikt op een regelaar met een pomp.

Wanneer het contact wordt geopend,

- De lokale pompuitgang wordt gestopt (zelfs als DIP1=ON, d.w.z. globale pomp op de regelaar).
- De actuators zijn gesloten.
- De pomp/droger-LED knippert rood.
- De Heat en Cool LED knippert rood (bij verwarming) of blauw (bij koeling).
- Als de regelaar een subregelaar is, wordt de vraag naar verwarming of koeling niet naar de hoofdregelaar gestuurd.

U kunt een contactthermostaat gebruiken voor thermische beveiliging.

U kunt 2 contactthermostaten in serie installeren ter bescherming tegen zowel oververhitting als overkoeling (de beveiligingsingang geldt zowel in de verwarmings- als in de koelmodus).

Het product wordt geleverd met een lusje in de connector.

De pomp van de SH-HCM wordt geactiveerd wanneer ten minste één pompuitgang van de aansluitmodule SH-CD in het systeem wordt geactiveerd.

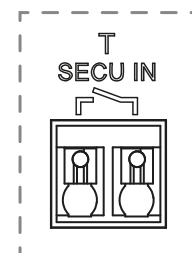

4.5 Ingang voor vochtigheidsdetectie

Het product heeft een ingang voor vochtigheidsdetectie.

Twee mogelijke signaaltypes volgens DIP8 (Zie 3.3):

- Watertemperatuursensor (CTN 10 kΩ): Vereist SH-DTH thermostaat.
- Een vochtigheidscontactsensor.

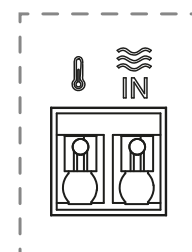

4.5.1 Vochtigheidscontactsensor (dauwpuntcontrole)

DIP8 = OFF

Aard van het signaal: De ingang is een vrij contact

Geen vochtigheid	Vochtigheid gedetecteerd
Geopend contact	Gesloten contact

In de koelmodus, wanneer vochtigheid wordt gedetecteerd, zal de regelaar

- Pompsignaal stoppen .
- Alle aandrijvingen sluiten.
- De vochtigheidsalarmeren naar alle andere SH-CD in het systeem sturen.
- Via de SH-HCM om de ontvochtiger inschakelen.

Als de regelaar een subregelaar is, wordt de koelvraag niet naar de hoofdregelaar gestuurd.

4.5.2 Watertemperatuursensor

DIP8 = ON

Er zijn 2 toepassingen van de watertemperatuurmeting:

Vochtigheidsdetectie

In de koelmodus berekent de regelaar voor elke zone het dauwpunt op basis van de omgevingstemperatuur en de relatieve vochtigheid die door elke thermostaat worden doorgegeven (Thermostaat met relatieve vochtigheidssensor is vereist). Wanneer de watertemperatuur in één zone het dauwpunt bereikt, zal de regelaar:

Veiligheidsaanpak DIP7 = OFF	Comfort benadering DIP7 = ON
Sluit de actuator van de zone en stopt de koelvraag van de zone.	Houd de actuator van de zone gedurende één uur open en sluit daarna de actuator en stopt de koelvraag in de zone als het vochtigheidsalarm nog steeds ingeschakeld is.

- Ontvochtiger op afstand van de zone inschakelen.
- Verzoekt de SH-HCM om de globale ontvochtiger voor minstens 15 min in te schakelen en tot het verdwijnen van het alarm als er geen externe ontvochtiger beschikbaar is in de zone.

Als de regelaar een subregelaar is, wordt de koelvraag van de zone niet naar de hoofdregelaar gestuurd.

Detectie van de verwarmings- en koelingsmodus

Wanneer DIP4 = ON en DIP5 = ON (H&C schakelaarbesturing = SH-CD) en DIP8 = ON wordt de watertemperatuur gebruikt om automatisch de H&C-modus te detecteren.

- Als de watertemperatuur > 24 °C, staat het systeem in de verwarmingsstand.
- Als de watertemperatuur < 20 °C, staat het systeem in de koelstand.

Deze functie is nuttig wanneer de Warmtepomp automatisch in de verwarmings- of koelmodus schakelt en geen uitgang heeft om het systeem te informeren.

Als de SH-HCM een watertemperatuur meet, wordt de temperatuur verzonden naar de SH-CD, die kan worden gebruikt als er geen watertemperatuursensor is.

Als H&C ingang = koelstand, schakelt het systeem in koelstand ongeacht de watertemperatuur.

4.6 NC/NO actuators

Sluit één NC- of NO-actor per connector aan

- 230 V aandrijvingen voor SH-CD-230
- 24 V aandrijvingen voor SH-CD-24

Het type aandrijving wordt bepaald door DIP2.

Voor alle aandrijvingen moet hetzelfde type worden gebruikt. Wanneer er in een zone vraag is naar verwarming of koeling, wordt de actuator onmiddellijk geactiveerd.

Wanneer de verwarmings- of koelvraag wordt gestopt, wordt de actuator onmiddellijk gesloten, behalve als dit de laatst geopende actuator in de regelaar is. In dat geval is de vertraging voordat het sluiten van de actuator begint afhankelijk van DIP3 (Zie 3.3)

- als DIP3=OFF, wacht het systeem 5 min voor het sluiten van de laatste actuator.
- indien DIP3=ON, wacht het systeem 20 min alvorens de laatste actuator te sluiten

Toelichting: Veel warmtepompen hebben een ingebouwde uitschakelvertraging (om opeenvolgende uitschakelingen te vermijden). In dit geval blijft de warmtepomp nog x minuten na de eigenlijke uitschakeltijd draaien. Het is belangrijk om ten minste één circuit open te houden, tenzij er een buffervat, hydraulische schakelaar of bypass in de installatie aanwezig is.

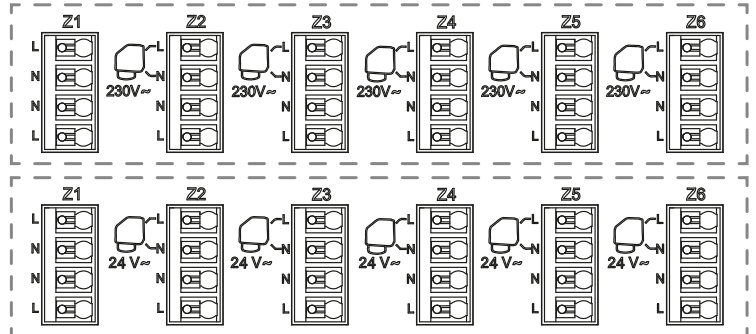

4.7 Externe antenne

De controller heeft een interne antenne. Indien nodig kan een externe antenne worden aangesloten om de RF-communicatie te verbeteren. Dit kan nuttig zijn als de controller in een metalen omkasting wordt geïnstalleerd. In dat geval moet u de externe antenne buiten de metalen omkasting installeren.

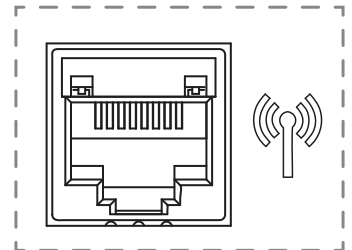

Respecteer de montage om de veiligheid te optimaliseren en storingen te voorkomen.

De antenne moet geïnstalleerd zijn:

- buiten de metalen omkasting
- in verticale positie en ten minste op 50 cm van metalen delen

Als u meerdere antennes heeft (meerdere controllers), moeten deze op minimaal 80 cm van elkaar worden geplaatst.

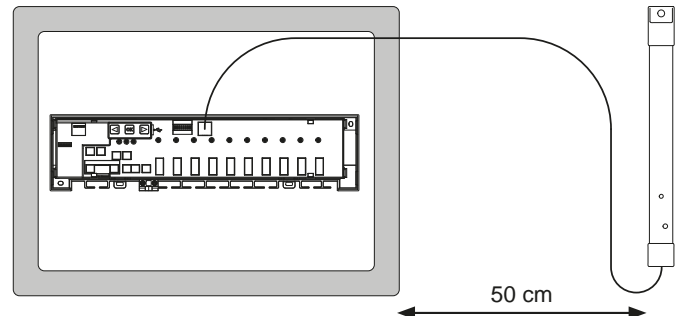





5. Systemconfiguratie

5.1 Systemconfiguratie zonder centrale

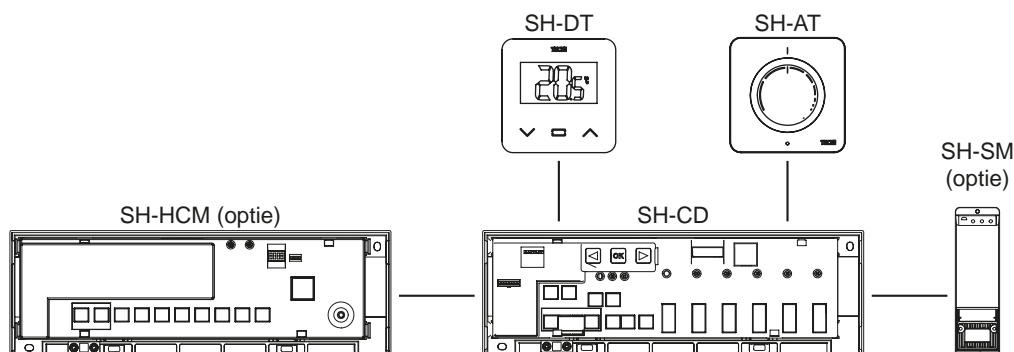
5.1.1 Standalone installatie

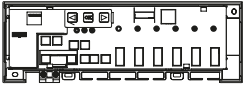
Slechts één controller of meerdere controllers zonder interconnectie

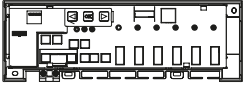
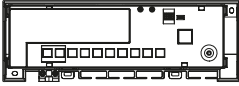
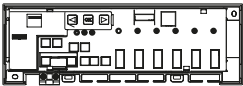

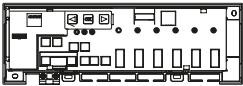
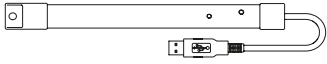
Apparaat 1	Apparaat 2	Opmerkingen
 <p>Door 5 seconden op OK te drukken, gaat de regelaar in de RF koppelingsmodus. Selecteer met ◀ of ▶ zone 1 (LED knippert rood), druk op OK om naar de modus Koppelen met thermostaat te gaan. Een groen knipperende LED is een positie-indicator. Beweeg de groen knipperende LED met ◀ of ▶ om de te koppelen zone(s) te selecteren. Selecteer/deselecteer de zone met OK. Geselecteerde zone is vast rood, maar blijft groen knipperen (positie-indicator). Reeds gekoppelde zone is vast groen.</p>	 <p>Thermostaten: Stel het product in op de RF koppelingsmodus (raadpleeg de handleiding van het betreffende apparaat).</p>	<p>Als RF-koppeling plaatsvindt, moeten de LED's van de op de SH-CD geselecteerde zones uitgaan en moeten de thermostaten de koppelingsmodus verlaten.</p> <p>Om een andere thermostaat te koppelen, moet u de modus opnieuw openen/starten.</p> <p>Verlaten van het koppelingsmenu van de regelaar: Lang indrukken op ◀.</p>
 <p>Door gedurende 5 seconden op OK te drukken, gaat de regelaar naar het RF koppelingsmenu. Selecteer met ◀ of ▶ zone 3 (LED knippert rood), druk op OK om naar de modus Koppelen met een slaafapparaat te gaan. Alle LED's knipperen groen.</p>	 <p>Zet het apparaat SH-HCM in de RF-koppelingsmodus. Druk gedurende 10 seconden op de knop. Meer informatie vindt u in de handleiding van het betreffende apparaat.</p>	<p>Wanneer de koppeling is voltooid, keert de SH-CD terug naar de koppelingsmenu en de SH-HCM naar de normale modus.</p> <p>Verlaten van het koppelingsmenu van de regelaar: Lang indrukken op ◀.</p> <p>OPMERKING: slechts één warmtekoelmodule SH-HCM per installatie.</p>
 <p>Door gedurende 5 seconden op OK te drukken, gaat de regelaar naar het RF koppelingsmenu. Selecteer met ◀ of ▶ zone 3 (LED knippert rood), druk op OK om naar de modus Koppelen met een slaafapparaat te gaan. Alle LED's knipperen groen.</p>	 <p>Stel de SH-SM in op de RF-koppelingsmodus. Druk gedurende 5 seconden op de knop. Raadpleeg de handleiding van het apparaat voor meer informatie.</p>	<p>Wanneer de verbinding klaar is, verlaat SH-SM de koppelingsmodus. SH-CD keert terug naar de koppelingsmodus.</p> <p>Verlaten van het koppelingsmenu van de regelaar: Lang indrukken op ◀.</p>
 <p>Door gedurende 5 seconden op OK te drukken, gaat de regelaar naar het RF koppelingsmenu. Selecteer met ◀ of ▶ zone 3 (LED knippert rood), druk op OK om naar de modus Koppelen met een slaafapparaat te gaan. Alle LED's knipperen groen.</p>	 <p>Stel de SH-R in op de RF-koppelingsmodus. Druk gedurende 3 seconden op de knop. Raadpleeg de handleiding van het apparaat voor meer informatie.</p>	<p>Wanneer de verbinding klaar is, verlaat SH-R de koppelingsmodus. SH-CD keert terug naar de koppelingsmodus.</p> <p>Verlaten het koppelingsmenu van de regelaar: Lang indrukken op ◀.</p>

5.1.2 Installatie van meerdere controllers

Als er meerdere onderling verbonden controllers in de installatie zijn, zijn er 1 hoofdcontroller (Main SH-CD) en maximaal 3 subcontrollers (Sub SH-CD).

De hoofdregelaar centraliseert de informatie voor de subregelaars. Als een warmtekoelmodule SH-HCM wordt gebruikt, moet deze worden gekoppeld aan de hoofdregelaar.

- De hoofdregelaar geeft de verwarmings- en koelmodus door aan de subregelaars. Deze informatie kan komen van de SH-HCM of van een Master Digital thermostaat volgens de DIP4 en DIP5 (Zie 3.3)
- De hoofdregelaar kan het pompsignaal van de hele installatie verwerken volgens DIP1 (Zie 3.3)

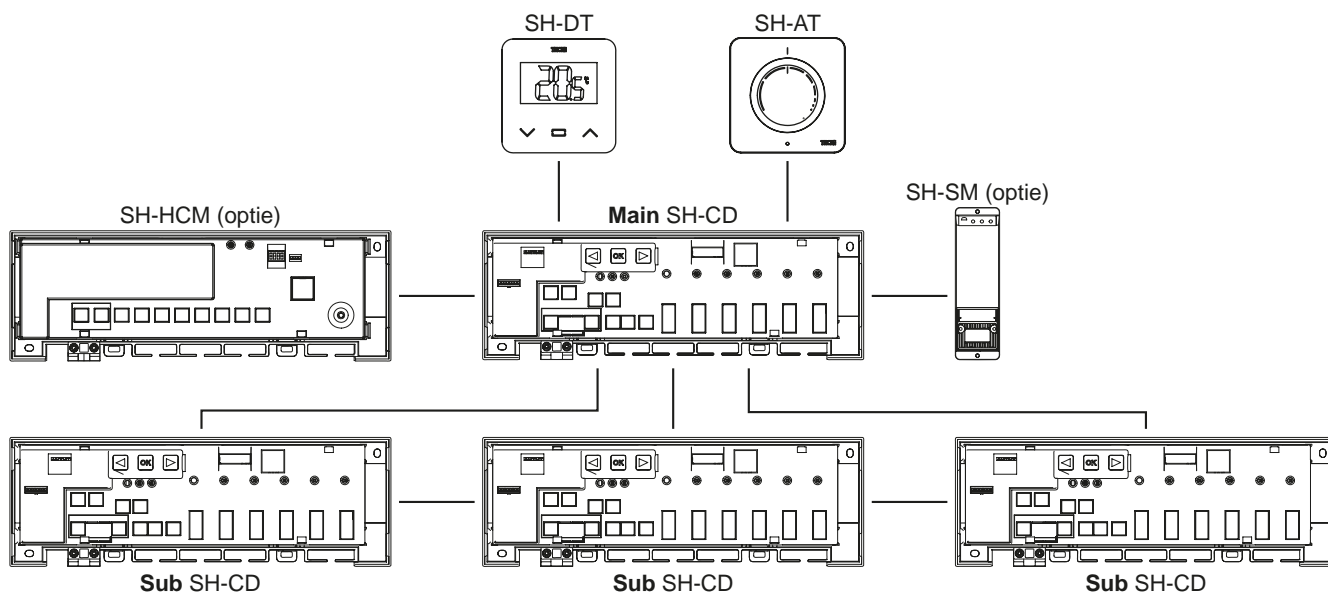

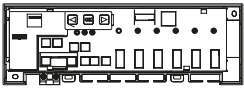
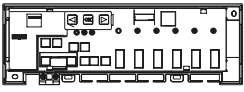
Apparaat 1: Hoofdcontroller	Apparaat 2: Subcontroller	Opmerkingen
Ten eerste moeten alle draadloze thermostaten worden gekoppeld aan de betreffende SH-CD-regelaar! Zie 5.1.1		
 <p>Door gedurende 5 seconden op OK te drukken, gaat de regelaar naar het RF koppelingsmenu.</p> <p>Selecteer met ◀ oder ▶ zone 3 (LED knippert rood), druk op OK om naar de modus Koppelen met een slaafapparaat te gaan.</p> <p>Alle LED's knipperen groen.</p>	 <p>Door gedurende 5 seconden op OK te drukken, gaat de regelaar naar het RF koppelingsmenu.</p> <p>Selecteer met ◀ oder ▶ zone 2 (LED knippert rood), druk op OK om naar de modus Koppelen met een masterapparaat te gaan.</p> <p>Alle LED's knipperen rood.</p>	<p>Wanneer de RF-koppeling is voltooid, keren beide SH-CD terug naar de koppelingsmodus.</p> <p>Verlaten van het controller koppelingsmenu: Lang indrukken op ◀.</p>

5.2 Systemconfiguratie met centrale eenheid

De centrale eenheid centraliseert de communicatie tussen de regelaars.

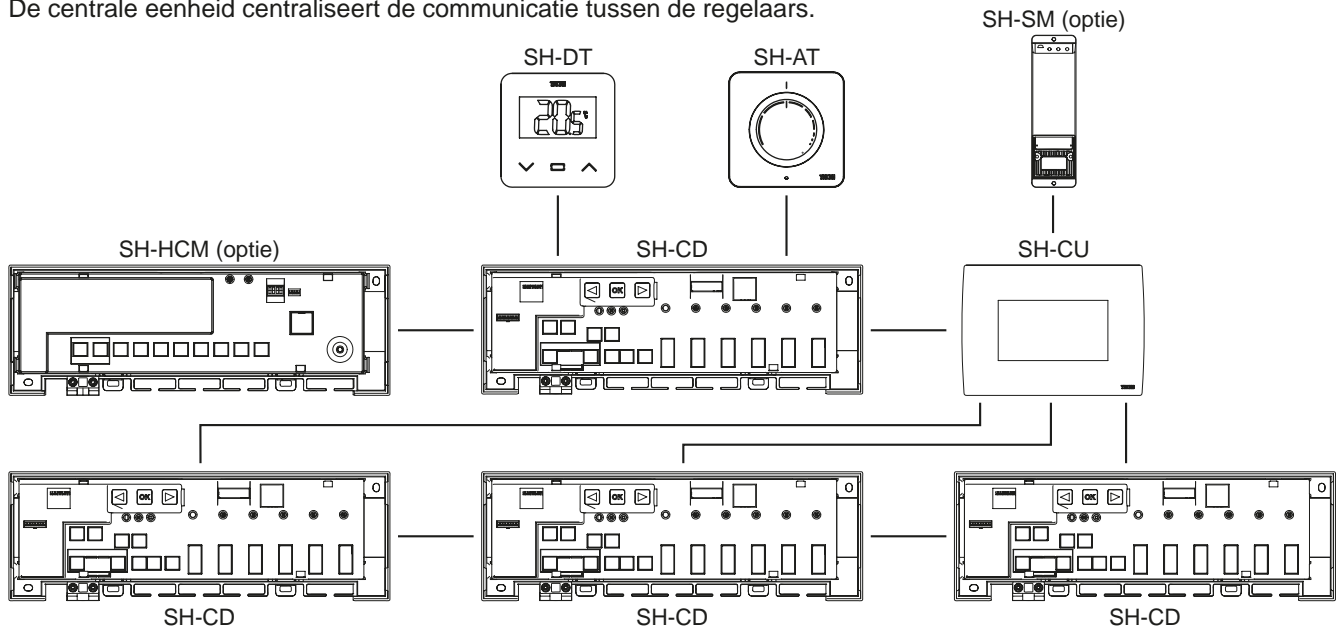

Apparaat 1: SH-CD	Apparaat 2: SH-CU	Opmerkingen
Ten eerste moeten alle draadloze thermostaten worden gekoppeld aan de betreffende SH-CD -regelaar! Zie 5.1.1		
 <p>Door gedurende 5 seconden op OK te drukken, gaat de regelaar naar het RF koppelingsmenu.</p> <p>Selecteer met ◀ oder ▶ zone 2 (LED knippert rood), druk op OK om naar de modus Koppelen met een masterapparaat te gaan.</p> <p>Alle LED's knipperen rood.</p>	 <p>Zet het apparaat in de RF koppelingsmodus. Kies een ruimte (Ruimte 1).</p> <p>Bij het koppelen van een SH-CD met SH-CU wordt voor elke draadloze thermostaat een ruimte gegenereerd. Daarom moeten de ruimtes niet vooraf in de centrale worden aangemaakt.</p>	<p>Wanneer de RF-koppeling is voltooid, verlaten zowel de SH-CD als de SH-CU de koppelingsmodus.</p> <p>Verlaten van het menu voor het koppelen van de controller: Lang indrukken ◀.</p>

5.3 Regel een ontvochtiger per ruimte

Er zijn 2 manieren om vochtigheid te detecteren:

- Op regelaarniveau met behulp van de vochtigheidsdetectie-ingang (Zie 4.5).
- Op ruimteniveau als de thermostaat een relatieve vochtigheidssensor bevat.

Wanneer vochtigheid wordt gedetecteerd, zijn er 2 manieren om de ontvochtiger te activeren.

- Een globale ontvochtiger wordt geactiveerd door de SH-HCM als deze functie is geactiveerd op de SH-HCM.
- Een ontvochtiger wordt geactiveerd op het niveau van de ruimte waar de vochtigheid wordt gedetecteerd.

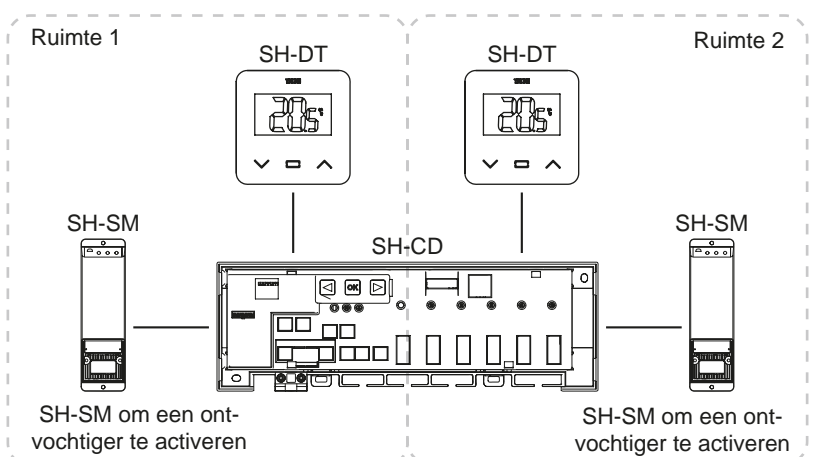

In dat laatste geval moet u een SH-SM-ontvanger koppelen aan elke zone van de regelaar om een ontvochtiger te activeren.

Apparaat 1: SH-CD	Apparaat 2: SH-SM	Opmerkingen
<p>Door gedurende 5 seconden op OK te drukken, gaat de regelaar naar het RF koppelingsmenu.</p> <p>Selecteer met ◀ of ▶ zone 4 (LED knippert rood), druk op OK om naar de ontvochtigingsmodus te gaan.</p> <p>Kies de zones met ◀ of ▶. Zones worden gedefinieerd door gekoppelde thermostaatkanalen. Bijvoorbeeld: TH1 = Z1, TH2 = Z2+Z3 en TH3 = Z4+Z5+Z6. De navigatie stelt 3 zones voor om een ontvochtiger te koppelen aan (Z1), (Z2+Z3) en (Z4+Z5+Z6).</p> <p>Selecteer/deselecteer de zone met OK. (U kunt slechts één zone per luchtontvochtiger selecteren). De cursor knippert groen.</p> <p>Geselecteerde zone knippert rood en groen. Reeds gekoppelde zone is vast groen.</p> <p>(Om een ontvochtiger te verwijderen, selecteer een zone in het groen, druk dan tegelijkertijd op f ◀ en ▶, omhoog om de zone in het groen te laten knipperen).</p>	<div data-bbox="890 309 932 434" style="text-align: center;"> </div> <p>Stel de SH-SM in op de RF-koppelingsmodus. Druk gedurende 5 seconden op de knop.</p> <p>Raadpleeg de handleiding van het apparaat voor meer informatie.</p>	<p>Wanneer de verbinding klaar is, verlaat SH-SM de koppelingsmodus.</p> <p>SH-CD keert terug naar de koppelingsmodus.</p> <p>Verlaten van de koppelingsmenu van de regelaar: Lang indrukken op ◀.</p>

6. Andere kenmerken

6.1 Anti Grip Eigenschap

De functie wordt ingeschakeld met DIP6 (zie 3.3). Als de kleppen gedurende een week niet actief zijn, wordt een volledige cyclus geactiveerd (actuator + pompuitgangen + warmte-/koelvraag naar de SH-HCM gestuurd).

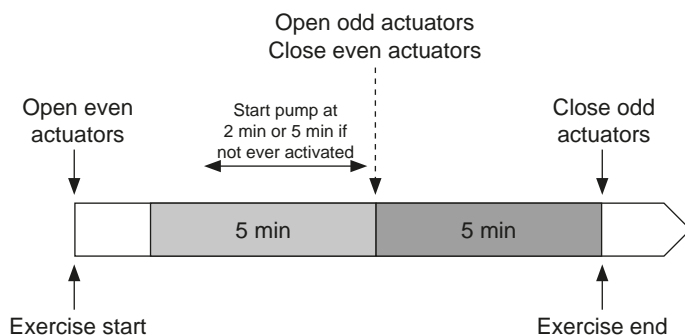

6.2 Reset

In geval van storingen kan het nodig zijn de regelaar terug te zetten naar de fabrieksinstelling. Door gedurende 5 seconden op **▶** te drukken, gaat de regelaar naar het Reset-menu. LED van zone 1 begint rood te knipperen, de overige zone-LEDS beginnen groen te knipperen.

Door dan gelijktijdig op **◀**, **OK** en **▶** te drukken tot alle zone-LEDS rood worden, wordt de besturingsreset geactiveerd en start het product opnieuw op. LEDES gaan uit.

6.3 Problemen oplossen

Symptoom	Problemen	Beschrijving	Problemen oplossen
Rood of blauw knipperen van de LED's Warmte en Koel en rood knipperend op Pomp/Droger LED	Veiligheidsdetectie	Het contact van de beveiligingsingang is geopend	Als u geen maximaal thermostaat gebruikt, zorg er dan voor dat u een band op de ingang van de veiligheidsthermostaat hebt geïnstalleerd. Controleer anders de temperatuur van de leiding (te warm in de verwarmingsmodus, te koud in de koelmodus).
Rood/Blauw knipperen op Verwarmen en Koelen LED	RF kwestie	De regelaar heeft de verbinding met een ander RF apparaat dan een thermostaat verloren.	Controleer de afstand tussen de apparaten. Als de controller in een metalen omkasting is geïnstalleerd, gebruik dan een externe antenne buiten de metalen omkasting. Een RF-repeater kan nodig zijn.
Snel blauw knipperen op Pomp/Droger LED	Probleem met de vochtigheidsconfiguratie	NTC-meting op H&C-ingang terwijl de DIP8 = OFF. ON/OFF ingang op H&C ingang terwijl de DIP8 = ON	Controleren of NTC-sensor en DIP-schakelaarinstelling
Rood knipperend op 1 zone	RF fout met de thermostaat	De regelaar heeft de verbinding met de thermostaat verloren.	Controleer de afstand tussen de regelaar en de thermostaat. Een RF-repeater kan nodig zijn.
Rood knipperend op alle zones	RF antenne fout	De regelaar heeft alle RF verbindingen verloren (Thermostaat en andere apparaten)	Een externe antenne kan nodig zijn.

7. TECHNISCHE KENMERKEN

7.1 Technische gegevens

	SH-CD6-24, SH-CD6-230, SH-CD10-24, SH-CD10-230
Elektrische bescherming	Klasse II met functionele aarde
IP Bescherming	IP30
Verzend- en opslagtemperatuur	-10 °C tot 50 °C (14 °F tot 122 °F)
Stroomvoorziening	230 V AC ± 10 % 50 Hz
Maximale uitgangsbelasting (2 uitgangen)	Relais: 5 A
Actuators	230 V/24 V NC/NO tot 2 W
Compatibiliteit	SH-AT, SH-DT, SH-DTP, SH-HCM, SH-CU, SH-SM

7.2 Afmetingen en gewicht

SH-CD6-24 en SH-CD6-230:

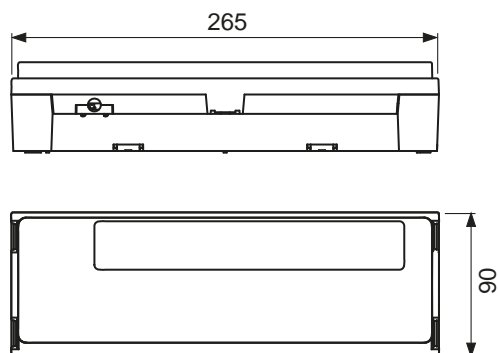

SH-CD10-24 en SH-CD10-230:

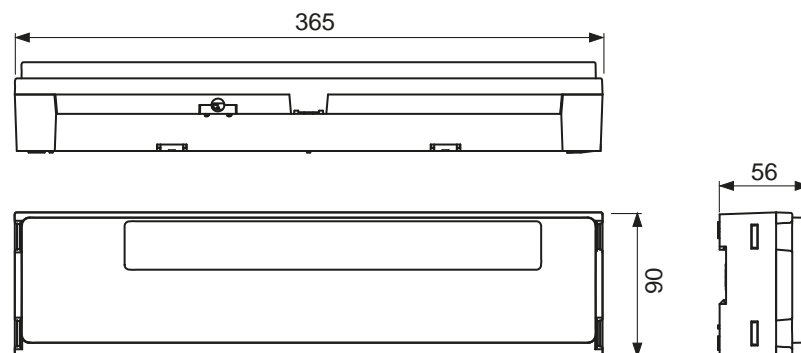

Gewicht: 840 g - SH-CD6
940 g - SH-CD10

8. RICHTLIJNEN

Aanwijzing	Beschrijving	Link
Laagspanningsrichtlijn (LVD)	De laagspanningsrichtlijn (LVD) (2014/35/EU) zorgt ervoor dat elektrisch materiaal binnen bepaalde spanningsgrenzen een hoog beschermingsniveau biedt aan Europese burgers en volledig profiteert van de interne markt.	2014/35/UE
Elektromagnetische compatibiliteit (EMC) Richtlijn 2014/30/EU	De Richtlijn Elektromagnetische Compatibiliteit (EMC) 2014/30/EU zorgt ervoor dat elektrische en elektronische apparatuur geen elektromagnetische storingen veroorzaakt of er geen hinder van ondervindt.	2014/30/UE
Beperking van het gebruik van bepaalde richtlijn gevaarlijke stoffen (RoHS) 2011/65/EU	Richtlijn inzake de beperking van het gebruik van bepaalde gevaarlijke stoffen in elektrische en elektronische apparatuur.	2011/65/EU
Elektrisch afval & elektronische apparatuur Richtlijn (WEEE)	De AEEA-richtlijn (2012/19/EU) heeft tot doel de hoeveelheid afgedankte elektrische en elektronische apparatuur die op de stortplaats terecht komt, te verminderen.	2012/19/EU
Commissie ecologisch ontwerp Verordening	Eisen inzake ecologisch ontwerp voor lokale ruimteverwarmers.	2015/1188
Richtlijn radioapparatuur (RED) 2014/53/EU	De Richtlijn radioapparatuur 2014/53/EU (RED) stelt een regelgevingskader vast voor het op de markt brengen van radioapparatuur.	2014/53/EU

Rukerveiledning

1. GENERELL INFORMASJON	88
1.1 Sikkerhetsadvarsler og bruksanvisning	88
1.2 Søknad	88
2. PRESENTASJON	88
2.1 Funksjoner	88
2.2 Boksens innhold	89
2.3 Første installasjon	89
3. PRODUKTBESKRIVELSE	89
3.1 LED-fargebetydninger	89
3.2 Nøkler	89
3.3 DIP-bryterkonfigurasjon	90
3.4 USB-minnepinne	90
4. INNGANGER/UTGANGER	91
4.1 Strømforsyning	91
4.2 Inngang for oppvarming/kjøling (H&C)	91
4.3 Pumpeutgang	92
4.4 Kontakt for temperaturbegrensning	92
4.5 Inngang for deteksjon av luftfuktighet	92
4.6 NC/NO aktuatorer	93
4.7 Ekstern antenne	94
5. Systemkonfigurasjon	94
5.1 Systemkonfigurasjon uten sentralenhet	94
5.2 Systemkonfigurasjon med sentralenhet	97
5.3 Kontroller en avfukter per rom.	97
6. Andre funksjoner	98
6.1 Anti-grep-funksjon	98
6.2 Zurücksetzen	98
6.3 Feilsøking	99
7. TEKNISKE EGENSKAPER	99
7.1 Technische Daten	99
7.2 Dimensjoner og vekt	100
8. RETNINGSLINJER	100

1. GENERELL INFORMASJON

1.1 Sikkerhetsadvarsler og bruksanvisning

Dette produktet bør fortrinnsvis installeres av en kvalifisert fagperson. Under forutsetning av at vilkårene ovenfor overholdes, påtar produsenten seg ansvaret for utstyret i henhold til lovbestemmelsene. Alle instruksjonene i denne installasjons- og bruksanvisningen må følges når du arbeider med regulatoren. Feil som skyldes feil installasjon, feil bruk eller dårlig vedlikehold, medfører at produsentens ansvar bortfaller.



Ethvert forsøk på reparasjon opphever produsentens ansvar og garanti- og erstatningsplikt.

2012/19/EU (WEEE-direktivet): Produkter merket med dette symbolet kan ikke kastes som usortert husholdningsavfall i EU. For riktig resirkulering må du returnere dette produktet til din lokale leverandør når du kjøper tilsvarende nytt utstyr, eller levere det til et angitt innsamlingssted. For mer informasjon, se: www.recyclethis.info

1.2 Søknad

Regulatoren er konstruert for bruk i boliger, kontorlokaler og industrianlegg. Kontroller at installasjonen er i samsvar med gjeldende forskrifter før du tar den i bruk for å sikre at den brukes på riktig måte.

2. PRESENTASJON

Koblingsboksen SH-CD er spesielt utviklet for å styre gulvvarme- og kjølesystemet ditt. Den gjør det enkelt og raskt å koble til termostater og aktuatorer. 4 versjoner er tilgjengelige:

	230 V-versjon	24 V-versjon
6 soner	SH-CD6-230	SH-CD6-24 (krever ekstern 230 V / 24 V-transformator: SH-ST)
10 soner	SH-CD10-230	SH-CD10-24 (krever ekstern 230 V / 24 V-transformator: SH-ST)

2.1 Funksjoner

Den har flere integrerte funksjoner:

- Veggmontert eller montert på DIN-skinne.
- Push-in-kabeltilkoblinger med strekkavlastning.
- LED-statusindikering og DIP-bryter for innstilling av enheten.
- Administrer 6 eller 10 soner med 2 aktuatorer per sone.
- Enkel sammenslåing av soner på samme termostat.
- Konfigurasjon av flere systemer.
- H&C-inngang (230 V og spenningsfritt signal).
- Måling av vanntemperatur (sonde medfølger ikke) for deteksjon av fuktighet.
- Pumpe- eller kjeleutgang (230 V og spenningsfritt signal).
- Anti-grepshåndtering.
- kontakt for temperaturbegrensning.
- Intern RF-antenne, valgfri ekstern antenne.
- Fungerer med NC- og NO-aktuatorer.
- USB-tilkobling for programvareoppdatering og datalogging.

2.2 Boksens innhold



2.3 Første installasjon

Det er to måter å installere kontrolleren på:

- Veggmontert med 2 skruer.
- Monteres på en DIN-skinne.

3. PRODUKTBESKRIVELSE

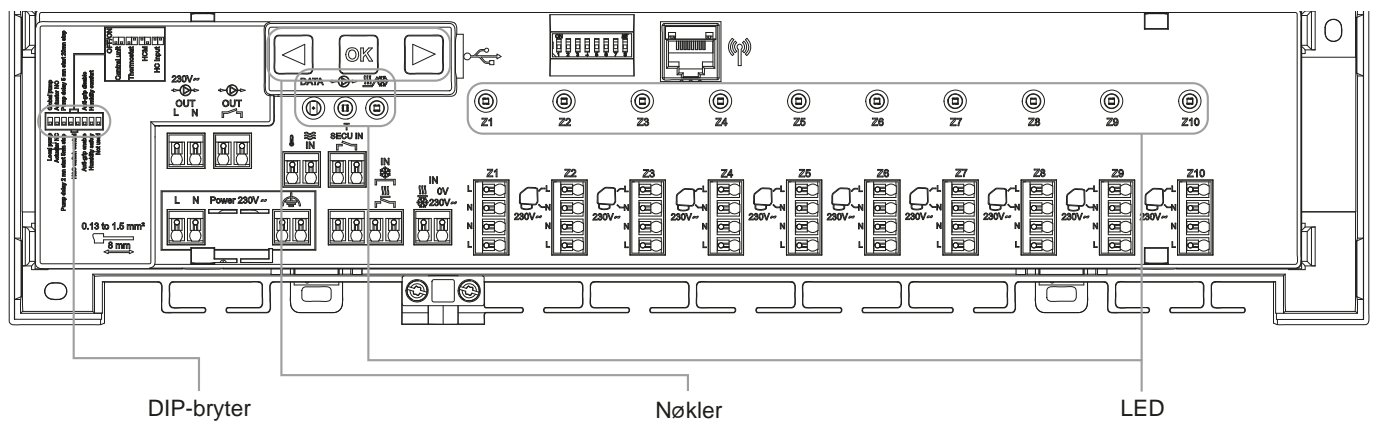

3.1 LED-fargebetydninger

LED	Betydning
Varme- og kjøle-LED (rød/blå)	Fikser rød = Oppvarmingsmodus. Fix Blue = Kjølemodus. Rødt blinkende (ved oppvarming) eller blått blinkende (ved kjøling) = Sikkerhetsdeteksjon Blinker rødt/blått = RF-tap (med SH-CD, SH-CD HCM RF 230, SH-CU intern antenne). Ved RF-tap går systemet over i oppvarmingsmodus.
LED for pumpe/tørketrommel (grønn/blå/rød)	Fikser grønn = Pumpen er utløst. Blinker rødt = Systemfeil (sikkerhetsdeteksjon / fuktighetssensorfeil/...). Blått blinkende = Global deteksjon av luftfuktighet. Blått blinkende = Problem med fuktighetskonfigurasjonen.
Data-LED (rød/grønn)	Grønt blinkende = Pågående datalogg.
LED per sone (rød/grønn)	Grønt blinkende = RF-overføring/mottak. Fikser rød = Varme- eller kjølebehov i sonen. Rødt blink = RF-feil med termostaten. Alle soner blinker rødt = RF-antennefeil. Ved RF-feil med SH-CD HCM eller SH-CU går systemet over i oppvarmingsmodus.

3.2 Nøkler

3 kapasitive taster er tilgjengelige.



3.3 DIP-bryterkonfigurasjon

Nummer på DIP-bryter	Funksjon	Verdi (standard: OFF)		Konfigurasjon	Beskrivelse
DIP1	Kontrollerfunksjon	OFF		Lokal (Krav til denne skinnen)	Se 4.3
		ON		Global (Krav fra annen enhet i systemet)	
DIP2	Aktuator typer	OFF		NC-styreenheter	Se 4.6
		ON		NO-styreenheter	
DIP3	Pumpestartforsinkelse (for den første aktuatoren som er i bruk) og aktuatorstoppforsinkelse (for den siste aktuatoren som er i bruk).	OFF		2 min / 5 min	Se 4.3 og 4.6
		ON		5 min / 20 min	
DIP4 og DIP5	Styring av H&C-bryter	OFF	OFF	Sentralenhet SH-CU	Se 4.2
		OFF	ON	Hovedtermostat SH-DT	
		ON	OFF	SH-CD HCM RF 230	
		ON	ON	SH-CD	
DIP6	Anti Grip	OFF		Aktivert	Se 6.1
		ON		Funksjonshemmet	
DIP7	Håndtering av luftfuktighet	OFF		Sikkerhetstilnærming	Se 4.5
		ON		Komfortabel tilnærming	
DIP8	Fuktighetssensor	OFF		PÅ/AV-sensor	Se 4.5
		ON		Sensor for vanntemperatur	

3.4 USB-minnepinne

USB-tilkobling gjør det mulig:

- For å oppdatere programvaren til styreenheten.
- For å registrere data for systemovervåking (datalog).

For programvareoppdateringen, se www.tece.com for å hente filen, og legg filen på en USB-pinne.

Sett inn USB-minnepinnen i kontrolleren.

- Slå av/på regulatoren.
- Under oppdatering,
 - Grønn LED er på fra Z1 til Z6/Z10.
 - Alle LED blir røde
 - Rød LED er slått av fra Z6/Z10 til Z1
- Etter oppdateringen kan du fjerne USB-pinnen.

Ved feilsøking kan dataloggen brukes til å registrere data i en ASCII-fil som lagres på USB-dongelen for feilsøking. Ved å trykke på i 5 sekunder går masteren inn i funksjonsmenyen. Lysdioden for den første sonen blinker enten rødt (datalogging er aktivert) eller grønt (datalogging er deaktivert). Du kan aktivere eller deaktivere dataloggen ved å klikke på .

Langt trykk på gjør det mulig å forlate funksjonsmenyen (ellers er det en timeout på 10 sekunder før funksjonsmenyen forlattes automatisk).

Det opprettes 1 loggfil hver 14. dag. I filen opprettes det en oppføring hvert 10. minutt.

4. INNGANGER/UTGANGER

4.1 Strømforsyning

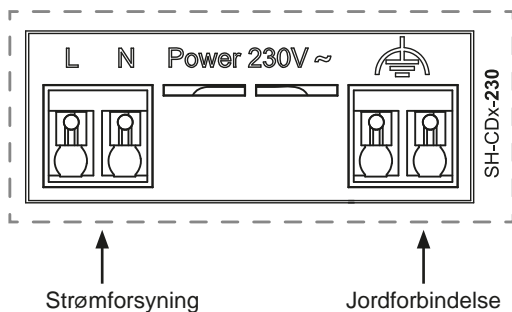

Krever bruk av transformator levert av Watts (4 kabler): SH-ST

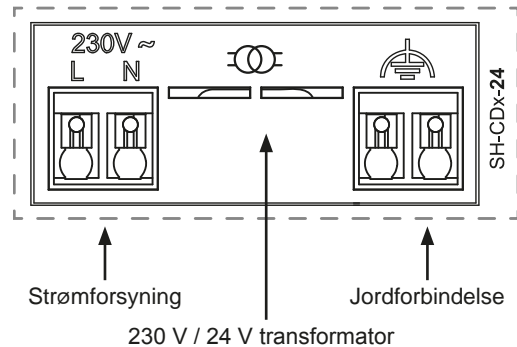

4.2 Inngang for oppvarming/kjøling (H&C)

Formål:

Denne inngangen gjør det mulig å bytte reguleringsmodus for systemet: Oppvarming eller kjøling.

Kilden til signalet:

- En mekanisk bryter
- En varmepumpe
- En SH-SM koblet til SH-CU-sentralenheten som en PÅ/AV-enhet. Denne løsningen gjør det mulig å fjernstyre H&C-modus fra applikasjonen.

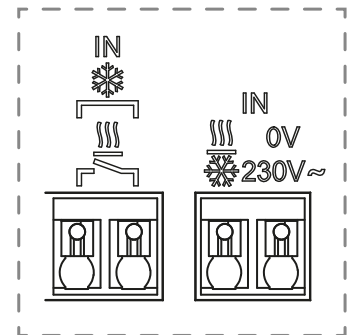

Signalets format: Inngangen kan være fri kontakt eller strømførende kontakt 230 V.

Modus	Gratis kontakt	Direkte kontakt
Oppvarming	Åpnet	Ikke noe signal
Kjøling	Stengt	230 V vekselstrøm

Bare én enhet i systemet skal kunne velge H&C-modus. Andre mulige signalkilder for H&C-bryteren (se 3.3)

- Sentralenhet (still inn manuell H&C-modus i installatørmenyen på sentralen) DIP4/DIP5 = OFF/OFF.
- SH-CD HCM RF 230 som inneholder en H&C-inngang DIP4/DIP5 = ON/OFF.
- Digital termostat konfigurert som en Master H&C-termostat i manuell eller automatisk modus (kun én termostat per installasjon) DIP4/DIP5 = OFF/ON.

Hvis du har flere tilkoblingsbokser SH-CD i systemet, bør H&C-modus bare styres av én styreenhet:

- Uten sentral anser systemet koblingsboksen som hoved SH-CD (se 5.1.2) DIP4/DIP5 = ON/ON.
- Med sentral:
 - Hvis koblingsboksen styrer H&C-modus, er DIP4/DIP5 = ON/ON.
 - Hvis sentralenheten styrer H&C-modus, er DIP4/DIP5 = OFF/OFF.

DIP4	DIP5	Skiftesignal H&C forespørsel fra
OFF	OFF	Sentralenhet (SH-CU)
OFF	ON	Termostat
ON	OFF	Varme- og kjølemodul (SH-CD-HCM RF 230)
ON	ON	Tilkoblingsboks (SH-CD)

4.3 Pumpeutgang

Det er to utganger:

- Strømførende kontaktutgang (230 Vac)
- Utgang med fri kontakt

Disse utgangene kan brukes til å trigge:

- En soneventil
- En pumpe
- Kjele eller varmepumpe

De 2 utgangene utløses når det er behov for oppvarming eller kjøling (se 3.3):

- I styreenheten hvis DIP-bryter 1 = OFF = lokal
- I systemet, hvis DIP-bryter 1 = ON = global

Forsinkelsen mellom varme- eller kjølebehovet og aktiveringen av pumpen kan konfigureres (se 3.3):

- Pumpen starter 2 minutter etter oppvarmings- eller kjølebehov hvis DIP-bryter 3 = OFF
- Pumpen starter 5 minutter etter oppvarmings- eller kjølebehov hvis DIP-bryter 3 = ON

Hensikten er å ta hensyn til aktuatorens latenstid.

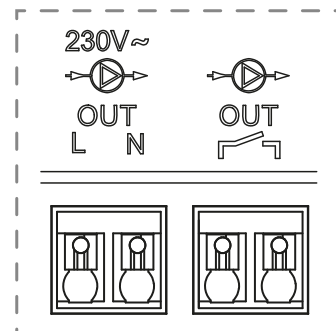

4.4 Kontakt for temperaturbegrensning

Dette er en sikkerhetsinngang (fri kontakt).

Lukket kontakt	Åpnet kontakt
Ingen sikkerhetsdeteksjon	Deteksjon av overoppheting eller overkjøling

Sikkerhetsinngangen bør brukes på en regulator med pumpe.

Når kontakten åpnes:

- Den lokale pumpeutgangen stoppes (selv om DIP1=ON, dvs. global pumpe på regulatoren).
- Aktuatorene er stengt.
- Lysdioden for pumpe/tørker blinker rødt.
- Varme- og kjøle-LED-en blinker rødt (ved oppvarming) eller blått (ved kjøling).
- Hvis regulatoren er en underregulator, sendes ikke varme- eller kjølebehovet til hovedregulatoren.

Du kan bruke en kontakttermostat for termisk sikkerhet. Du kan installere 2 kontakttermostater i serie for å beskytte mot både overoppheting og overkjøling (sikkerhetsinngangen er gyldig i både varme- og kjølemodus).

Produktet leveres med en stropp på kontakten.

Vær oppmerksom på at pumpen til SH-CD HCM RF 230 utløses når minst én pumpe av flere SH-CD installert i systemet utløses.

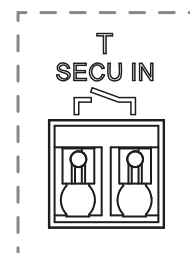

4.5 Inngang for deteksjon av luftfuktighet

Produktet har en inngang for deteksjon av luftfuktighet.

2 mulige signaltyper i henhold til DIP8 (se 3.3):

- En kontaktsensor for fuktighet.
- Sensor for vanntemperatur (CTN 10 kΩ): Krever SH-DTH-termostat.

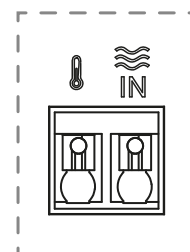

4.5.1 Kontaktsensor for luftfuktighet (duggpunktkontroll)

DIP8 = OFF

Signalets format: Inngangen er en fri kontakt.

Ingen fuktighet	Detektert fuktighet
Åpnet kontakt	Lukket kontakt

I kjølemodus, når fuktighet detekteres, vil regulatoren:

- Stopper pumpe-signalet.
- Stenger alle aktuatorer.
- Sender fuktighetsalarmen til alle andre SH-CD i systemet.
- Ber SH-HCM om å aktivere avfukteren.

Hvis regulatoren er en underregulator, sendes ikke kjølebehovet til hovedregulatoren.

4.5.2 Sensor for vanntemperatur

DIP8 = ON

Det er to bruksområder for måling av vanntemperatur.

Deteksjon av luftfuktighet

I kjølemodus beregner regulatoren duggpunktet for hver sone basert på omgivelsestemperaturen og den relative fuktigheten som sendes fra hver termostat (termostat med relativ fuktighetssensor er påkrevd).

Når vanntemperaturen når duggpunktet i én sone, starter regulatoren:

Sikkerhetstilnærming DIP7 = AV	Komfortabel tilnærming DIP7 = ON
Steng aktuatoren for sonen og stopp kjølebehovet for sonen.	Hold aktuatoren for sonen åpen i én time, lukk deretter aktuatoren og stopp kjølebehovet i sonen hvis fuktighetsalarmen fortsatt utløses.

- Aktiver ekstern avfukting av sonen.
- Ber varme- og kjølemodulen SH-CD HCM RF 230 om å aktivere den globale avfukteren i minst 15 minutter og frem til alarmen forsvinner hvis ingen ekstern avfukter er tilgjengelig i sonen.

Hvis regulatoren er en underregulator, sendes ikke sonens kjølebehov til hovedregulatoren.

Deteksjon av varme- og kjølemodus

Når DIP4 = ON og DIP5 = ON (H&C-bryterstyring = SH-CD) og DIP8 = ON, brukes vanntemperaturen til automatisk å registrere H&C-modus.

- Hvis vanntemperaturen er > 24 °C, er systemet i oppvarmingsmodus.
- Hvis vanntemperaturen er < 20 °C, er systemet i kjølemodus.

Denne funksjonen er nyttig når varmepumpen automatisk skifter til varme- eller kjølemodus og ikke har noen utgang for å informere systemet.

- Hvis SH-CD HCM RF 230 måler en vanntemperatur:
Temperaturen sendes til SH-CD som kan brukes hvis det ikke finnes noen vanntemperatursensor.
- Hvis H&C-inngang = kjølemodus: Systemet skifter til kjølemodus uavhengig av vanntemperaturen.

4.6 NC/NO aktuatorer

Koble til én NC- eller NO-aktuator per kontakt.

- 230 V-aktuatorer for SH-CD-230
- 24 V-aktuatorer for SH-CD-24

Typen aktuatorer defineres av DIP2.

Det er nødvendig å bruke samme type for alle aktuatorer.

Når det er et varme- eller kjølebehov i en sone, utløses aktuatoren umiddelbart. Når varme- eller kjølebehovet stoppes, lukkes aktuatoren umiddelbart, unntatt hvis dette er den siste aktuatoren som er åpnet i regulatoren. I så fall er forsinkelsen før aktuatoren begynner å stenge avhengig av DIP3 (Se 3.3):

- Hvis DIP3 = OFF, venter systemet 5 minutter før den siste aktuatoren stenges.
- Hvis DIP3 = ON, venter systemet 20 minutter før den siste aktuatoren stenges.

Begrunnelse: Mange varmepumper har en innebygd utkoblingsforsinkelse (for å unngå gjentatte av/påkoblinger). I dette tilfellet fortsetter varmepumpen å gå i x minutter utover den faktiske utkoblingstiden. Det er viktig å holde minst én krets åpen, med mindre det finnes en buffertank, hydraulisk bryter eller bypass i installasjonen.

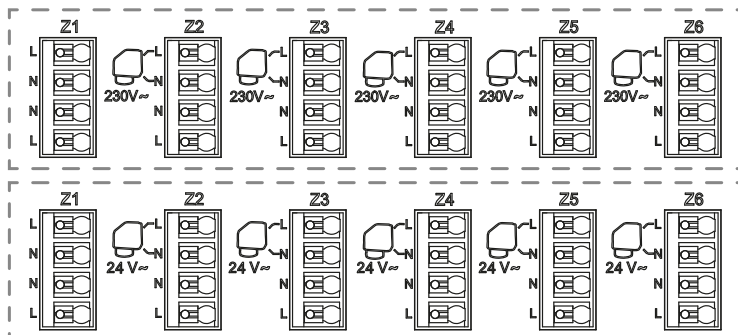

4.7 Ekstern antenne

Kontrolleren inneholder en intern antenne.

Ved behov kan en ekstern antenne kobles til for å forbedre RF-kommunikasjonen. Det kan være nyttig hvis styreenheten er installert inne i en metallboks. I så fall må du installere den eksterne antennen utenfor metallboksen.

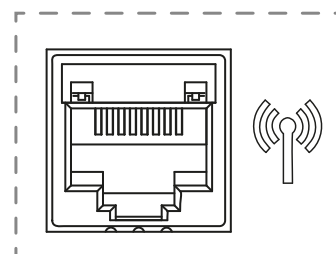

Respekter monteringen for å optimalisere følsomheten og unngå dysfunksjon.

Antenne må være installert:

- utenfor metallboksen
- i vertikal stilling
- og minst 50 cm fra metalliske deler.

Hvis du har flere antenner (flere kontrollere), må de plasseres minst 80 cm fra hverandre.

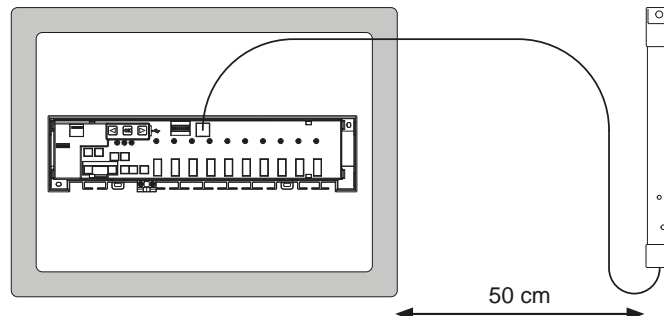



5. Systemkonfigurasjon

5.1 Systemkonfigurasjon uten sentralenhet

5.1.1 Frittstående installasjon

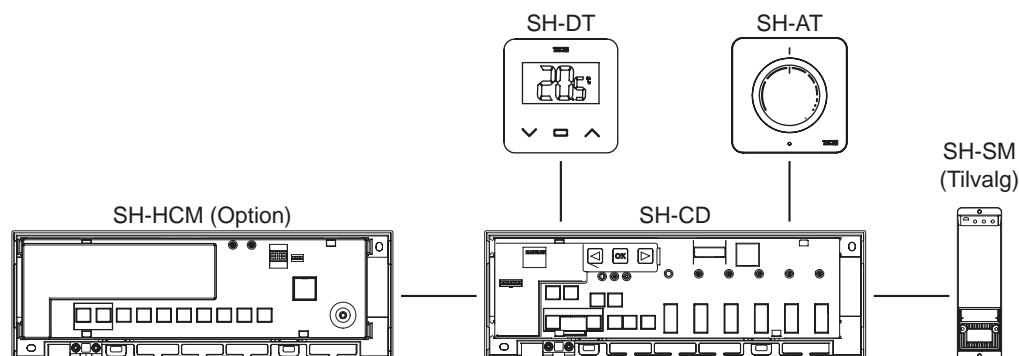
Bare én styreenhet eller flere styreenheter uten sammenkobling.

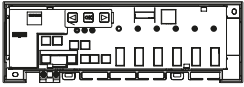
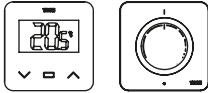
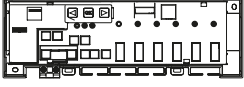
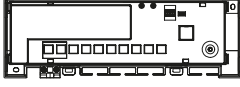
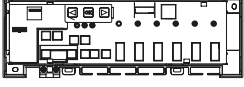

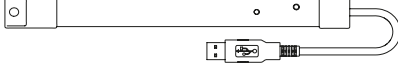
Enhet 1	Enhet 2	Merknader
 <p>Ved å trykke på OK i 5 sekunder går kontrolleren i RF-paringsmodus. Bruk ◀ eller ▶ til å velge sone 1 (LED-lampen blinker rødt), og trykk på OK for å gå inn i modus for sammenkobling med termostat. En grønn blinkende lysdiode er en posisjonsindikator. Flytt den grønne blinkende lysdioden med ◀ eller ▶ for å velge sonen(e) som skal pares. Velg/fravelg sone med OK. Valgt sone lyser rødt, men fortsetter å blinke grønt (posisjonsindikator). Den allerede sammenkoblede sonen er grønn.</p>	 <p>Termostater: Sett produktet i RF-paringsmodus (se tilhørende bruksanvisning).</p>	<p>Hvis RF-paring er utført, må lysdiodene for sonene som er valgt på SH-CD, slås av, og termostatene må gå ut av paringsmodus. For å koble sammen en annen termostat må du gå inn i / starte modusen på nytt. Gå ut av koblingsmodus for styreenheten: Trykk lenge på ◀.</p>
 <p>Ved å trykke på OK i 5 sekunder går kontrolleren til RF-paringsmenyen. Bruk ◀ eller ▶ til å velge sone 3 (LED-lampen blinker rødt), og trykk på OK for å gå inn i modus for sammenkobling med en slaveenhet. Alle lysdiodene blinker grønt.</p>	 <p>Sett enheten i RF-koblingsmodus. Trykk på knappen i 10 sekunder. Du finner mer informasjon i bruksanvisningen til det aktuelle apparatet.</p>	<p>Når koblingen er fullført, går SH-CD tilbake til koblingsmodus og SH-CD HCM RF 230 tilbake til normal modus. Gå ut av koblingsmodus for styreenheten: Trykk lenge på ◀. BEMERK: Kun én varmekjølemodul SH-CD HCM RF 230 per installasjon.</p>
 <p>Ved å trykke på OK i 5 sekunder går kontrolleren til RF-paringsmenyen. Bruk ◀ eller ▶ til å velge sone 3 (LED-lampen blinker rødt), og trykk på OK for å gå inn i modus for sammenkobling med en slaveenhet. Alle lysdiodene blinker grønt.</p>	 <p>Sett SH-SM i RF-koblingsmodus. Trykk på knappen i 5 sekunder. Du finner mer informasjon i bruksanvisningen til enheten.</p>	<p>Når koblingen er fullført, går SH-SM ut av koblingsmodus. SH-CD går tilbake til koblingsmodus. Gå ut av koblingsmodus for styreenheten: Trykk lenge på ◀.</p>
 <p>Ved å trykke på OK i 5 sekunder går kontrolleren til RF-paringsmenyen. Bruk ◀ eller ▶ til å velge sone 3 (LED-lampen blinker rødt), og trykk på OK for å gå inn i modus for sammenkobling med en slaveenhet. Alle lysdiodene blinker grønt.</p>	 <p>Sett SH-R i RF-koblingsmodus. Trykk på knappen i 3 sekunder. Du finner mer informasjon i bruksanvisningen til enheten.</p>	<p>Når koblingen er fullført, går SH-R ut av koblingsmodus. SH-CD går tilbake til koblingsmodus. Gå ut av koblingsmodus for styreenheten: Trykk lenge på ◀.</p>

5.1.2 Installasjon av flere kontrollere

Hvis det er flere sammenkoblede regulatorer i installasjonen, finnes det 1 hovedregulator (Main SH-CD) og opptil 3 underregulatorer (Sub SH-CD).

Hovedkontrolleren sentraliserer informasjonen til underkontrollerne. Hvis en varmekjølemodul SH-CD HCM RF 230 brukes, skal den kobles til hovedkontrolleren.

- Hovedkontrolleren viderefremidler varme- og kjølemodus til underkontrollerne. Denne informasjonen kan komme fra SH-CD HCM RF 230 eller fra en Master Digital-termostat, i henhold til DIP4 og DIP5 (se 3.3)
- Hovedkontrolleren kan håndtere pumpesignalet for hele installasjonen i henhold til DIP1 (Se 3.3)

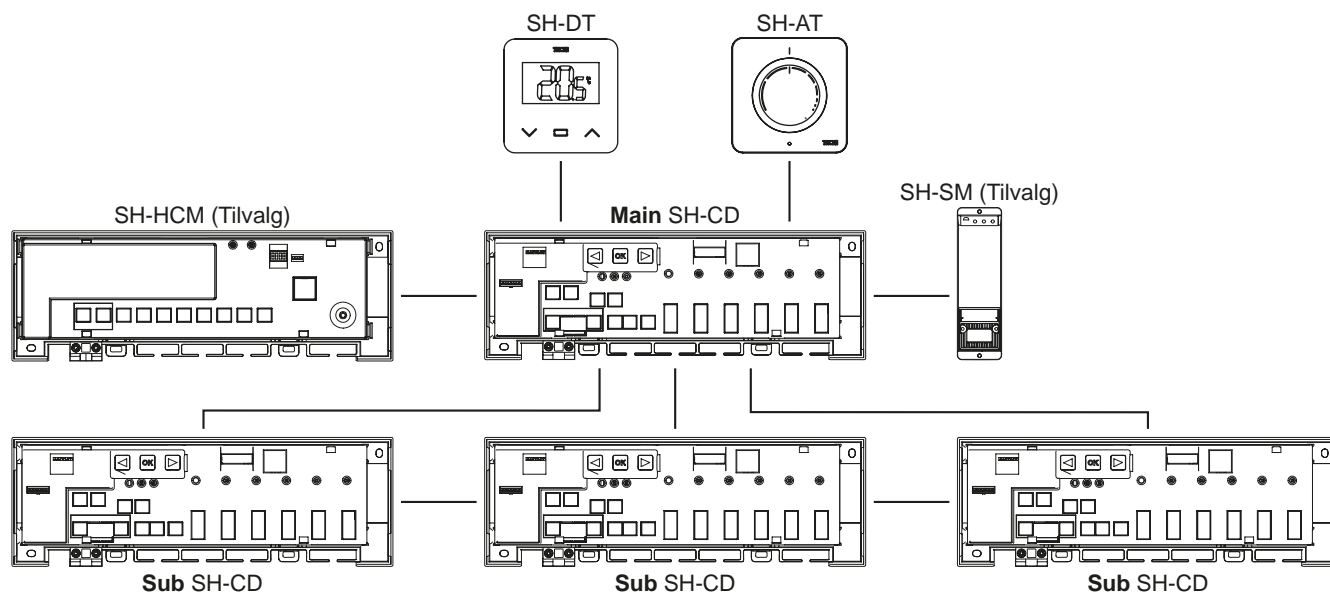

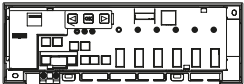
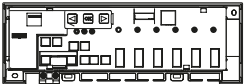
Enhet 1: Hovedkontroller	Enhet 2: Underkontroller	Merknader
For det første må alle radiostyrte termostater pares med den tilhørende SH-CD-kontrolleren! Se 5.1.1		
 <p>Ved å trykke på OK i 5 sekunder går kontrolleren til RF-paringsmenyen. Bruk ◀ eller ▶ til å velge sone 3 (LED-lampen blinker rødt), og trykk på OK for å gå inn i modus for sammenkobling med en slaveenhet. Alle lysdiodene blinker grønt.</p>	 <p>Ved å trykke på OK i 5 sekunder går kontrolleren til RF-paringsmenyen. Bruk ◀ eller ▶ til å velge sone 2 (LED-lampen blinker rødt), og trykk på OK for å gå inn i modus for sammenkobling med en masterenhet. Alle lysdiodene blinker rødt.</p>	<p>Når RF-paringen er fullført, går både SH-CD tilbake til paringsmodus. Gå ut av menyen for sammenkobling av kontrollere: Trykk lenge på ◀.</p>

5.2 Systemkonfigurasjon med sentralenhet

Sentralenheten sentraliserer kommunikasjonen mellom styreenhetene.

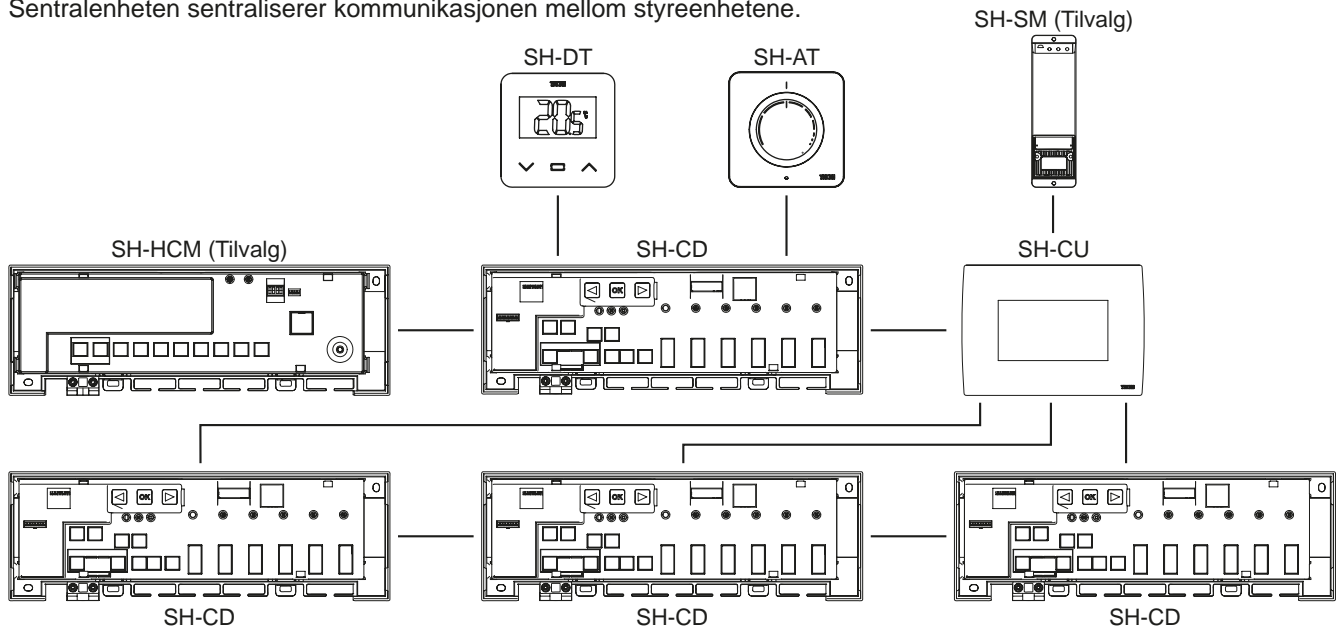

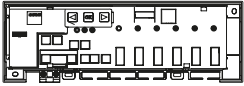
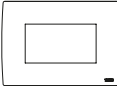
Enhet 1: SH-CD	Enhet 2: SH-CU	Merknader
For det første må alle radiostyrte termostater pares med den tilhørende SH-CD-kontrolleren! Se 5.1.1		
 <p>Ved å trykke på OK i 5 sekunder går kontrolleren til RF-paringsmenyen. Bruk ◀ eller ▶ til å velge sone 2 (LED-lampen blinker rødt), og trykk på OK for å gå inn i modus for sammenkobling med en masterenhet. Alle lysdiodene blinker rødt.</p>	 <p>Sett enheten i RF-paringsmodus. Velg et rom (rom 1). Ved sammenkobling av en SH-CD med CT-02 RF genereres det et rom for hver trådløse termostat. Rommene må derfor ikke opprettes i sentralenheten på forhånd.</p>	<p>Når RF-paringen er fullført, går både SH-CD og SH-CU ut av paringsmodus. Gå ut av menyen for sammenkobling av kontrollere: Trykk lenge på ◀.</p>

5.3 Kontroller en avfukter per rom.

Det er to måter å måle luftfuktighet på:

- På regulatornivå ved hjelp av fuktighetsdeteksjonsinngangen (se 4.5).
- På romnivå hvis termostaten har en sensor for relativ luftfuktighet.

Når fuktighet registreres, kan avfukteren utløses på to måter:

- En global avfukter utløses av SH-CD HCM RF 230 hvis funksjonen er aktivert på SH-CD HCM RF 230.
- En avfukter utløses på det romnivået der luftfuktigheten registreres.
- I så fall må du koble en SH-SM-mottaker til hver sone i regulatoren for å utløse avfukteren.

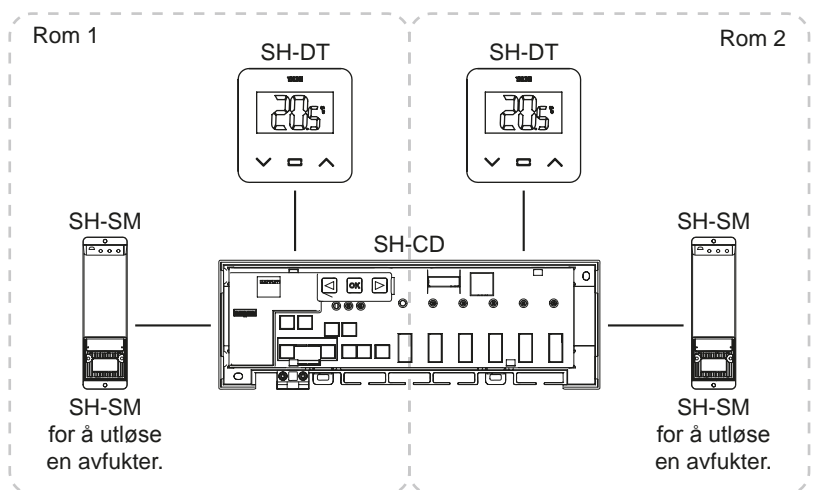

Enhet 1: SH-CD	Enhet 2: SH-SM	Merknader
<p>Ved å trykke på OK i 5 sekunder går kontrolleren til RF-paringsmenyen.</p> <p>Bruk ◀ eller ▶ til å velge sone 4 (LED-lampen blinker rødt), og trykk på OK for å gå inn i avfukterens paringsmodus.</p> <p>Velg sonene med ◀ eller ▶.</p> <p>Soner defineres av sammenkoblede termostatkanaler.</p> <p>For eksempel: TH1 = Z1, TH2 = Z2+Z3 og TH3 = Z4+Z5+Z6. Navigasjonen foreslår 3 soner for å koble en avfukter til (Z1), (Z2+Z3) og (Z4+Z5+Z6).</p> <p>Velg/fravelg sone med OK. (Du kan bare velge én sone per avfukter). Markøren blinker grønt.</p> <p>Valgt sone blinker rødt og grønt</p> <p>Den allerede sammenkoblede sonen er grønn.</p> <p>(For å fjerne en avfukter velger du en sone i grønt, og trykker deretter samtidig på ◀ og ▶ for å få sonen til å blinke grønt).</p>	 <p>Sett SH-SM i RF-koblingsmodus.</p> <p>Trykk på knappen i 5 sekunder.</p> <p>Du finner mer informasjon i bruksanvisningen til enheten.</p>	<p>Når koblingen er fullført, går SH-SM ut av koblingsmodus. SH-CD går tilbake til koblingsmodus.</p> <p>Gå ut av koblingsmodus for styreenheten: Trykk lenge på ◀.</p>

6. Andre funksjoner

6.1 Anti-grep-funksjon

Funksjonen aktiveres ved hjelp av DIP6 (Se 3.3). Hvis ventilene ikke er aktive i løpet av en uke, utløses en komplett øvelse (aktuator + pumpeutganger + varme-/kjølebehov sendt til SH-CD HCM RF 230).

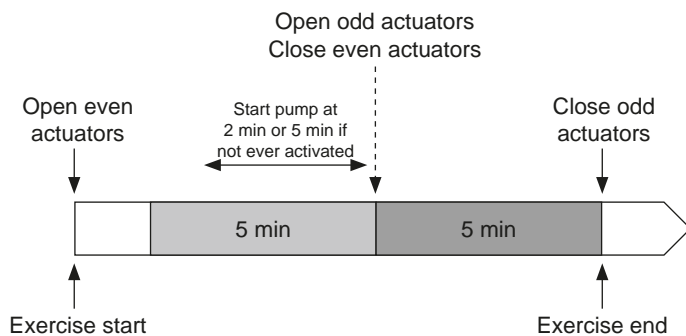

6.2 Zurücksetzen

Ved funksjonsfeil kan det være nødvendig å tilbakestille produktet til fabrikkinnstillingene.

Ved å trykke på **▶** i 5 sekunder går masteren inn i Reset-menyen. Lysdioden for sone 1 begynner å blinke rødt, mens lysdioden for de andre sonene begynner å blinke grønt.

Hvis du deretter trykker samtidig på **◀**, **OK** og **▶** for å få alle sonelysdiodene til å lyse rødt, tilbakestilles kontrolleren og produktet starter på nytt. Lysdiodene slås av.

6.3 Feilsøking

Symptom	Problemer	Beskrivelse	Feilsøking
Rød eller blå blinking på varme- og kjøle-LED-en og Rød blinking på pumpe/tørker-LED	Sikkerhetsdeteksjon	Kontakten til sikkerhetsinngangen er åpnet	Hvis du ikke bruker en sikkerhets-termostat, må du sørge for at du har installert en stropp på sikkerhetstermostatingangen. Ellers må du kontrollere temperaturen på røret (for varmt i oppvarmingsmodus, for kaldt i kjølemodus).
Rød/blå blinking på varme- og kjøle-LED-en	RF-problem	Kontrolleren har mistet forbindelsen med en annen RF-enhet enn en termostat.	Kontroller avstanden mellom enhetene. Hvis styreenheten er installert i en metallboks, må du bruke en ekstern antenne som er plassert utenfor metallboksen. En RF-repeater kan være nødvendig.
Rask blå blinking på pumpe/tørker-LED	Problem med fuktighets-konfigurasjon	NTC-måling på H&C-inngang mens DIP8 = OFF. ON/OFF-inngang på H & C-inngang, mens DIP8 = ON	Kontroller om NTC-sensoren og DIP-bryterens innstilling
Rødt blinkende på 1 sone	RF-feil med termostaten	Regulatoren har mistet forbindelsen til termostaten.	Kontroller avstanden mellom regulatoren og termostaten. En RF-repeater kan være nødvendig.
Alle soner blinker rødt	RF-antennefeil	Regulatoren har mistet alle RF-tilkoblinger (termostat og andre enheter).	Ekstern antenne kan være nødvendig.

7. TEKNISKE EGENSKAPER

7.1 Technische Daten

	SH-CD6-24, SH-CD6-230, SH-CD10-24, SH-CD10-230
Elektrisk beskyttelse	Klasse II med funksjonell jord
IP-beskyttelse	IP30
Transport- og lagringstemperatur	-10 °C til 50 °C (14 °F til 122 °F)
Strømforsyning	230 V vekselstrøm ± 10 % 50 Hz
Maksimal utgangsbelastning (2 utganger)	Relé : 5 A
Aktuatorer	230 V / 24 V NC/NO opp til 2 W
Kompatibilitet	SH-AT, SH-DT, SH-DTP, SH-HCM, SH-CU, SH-SM

7.2 Dimensjoner og vekt

SH-CD6-24 og SH-CD6-230:

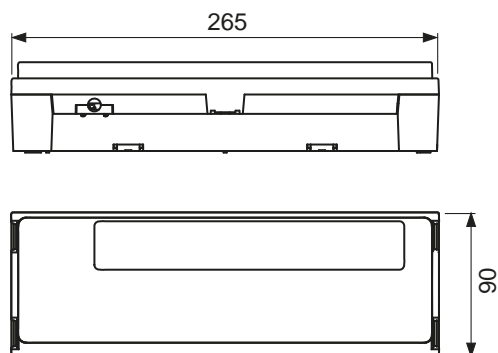

SH-CD10-24 og SH-CD10-v230:

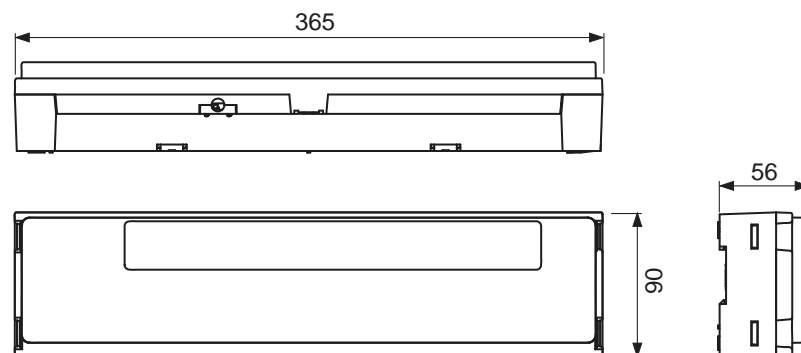

Gewicht: 840 g - SH-CD6
940 g - SH-CD10

8. RETNINGSLINJER

Betegnelse	Beskrivelse	Lenke
Lavspenningsdirektivet (LVD)	Lavspenningsdirektivet (LVD) (2014/35/EU) sikrer at elektrisk utstyr innenfor visse spenningsgrenser gir et høyt beskyttelsesnivå for europeiske borgere, og at de får full nytte av det indre markedet.	2014/35/UE
Elektromagnetisk kompatibilitet (EMC) Direktiv 2014/30/EU	Direktivet om elektromagnetisk kompatibilitet (EMC) 2014/30/EU sikrer at elektrisk og elektronisk utstyr ikke genererer eller påvirkes av elektromagnetiske forstyrrelser.	2014/30/UE
Begrensning av bruken av visse direktivet om farlige stoffer (RoHS) 2011/65/EU	Direktiv om begrensning av bruken av visse stoffer og farlige stoffer i elektriske og elektroniske produkter utstyr.	2011/65/EU
Elektrisk avfall & Elektronisk utstyr Direktiv (WEEE)	WEEE-direktivet (2012/19/EU) har som mål å redusere mengden elektrisk og elektronisk avfall som havner på deponi.	2012/19/EU
Kommisjonen for økodesign Regulering	Økodesignkrav for lokale romoppvarmere.	2015/1188
FDirektiv 2014/53/EU om radioutstyr (RED)	Radioutstyrsdirektivet 2014/53/EU (RED) etablerer et regelverk for markedsføring av radioutstyr.	2014/53/EU

ANVÄNDARGUIDE

1. ALLMÄN INFORMATION	102
1.1 Säkerhetsvarningar och bruksanvisningar	102
1.2 Tillämpning	102
2. PRESENTATION	102
2.1 Funktioner	102
2.2 Boxens innehåll	103
2.3 Första installationen	103
3. PRODUKTBESKRIVNING	103
3.1 LED-färgbeteckningar	103
3.2 Nycklar	103
3.3 Konfiguration av DIP-omkopplare	104
3.4 USB-minne	104
4. INGÅNGAR/UTGÅNGAR	105
4.1 Strömförsörjning	105
4.2 Ingång för uppvärmning/kylning (H&C)	105
4.3 Pumputgång	106
4.4 Kontakt för temperaturbegränsning	106
4.5 Ingång för detektering av luftfuktighet	106
4.6 NC/NO ställdon	107
4.7 Extern antenn	108
5. Systemkonfiguration	108
5.1 Systemkonfiguration utan centralenhet	108
5.2 Systemkonfiguration med centralenhet	111
5.3 Styr en avfuktare per rum.	111
6. Andra egenskaper	112
6.1 Anti-grepp-funktion	112
6.2 Återställ	112
6.3 Felsökning	113
7. TEKNISKA EGENSKAPER	113
7.1 Technische Daten	113
7.2 Mått och vikt	114
8. DIREKTIV	114

1. ALLMÄN INFORMATION

1.1 Säkerhetsvarningar och bruksanvisningar

Denna produkt bör installeras av en kvalificerad fackman. Under förutsättning att ovanstående villkor följs, åtar sig tillverkaren det ansvar för utrustningen som följer av lagstadgade bestämmelser.

Alla anvisningar i denna installations- och bruksanvisning ska följas när du arbetar med styrenheten. Fel som beror på felaktig installation, felaktig användning eller bristfälligt underhåll innebär att tillverkarens ansvar upphör att gälla.



Alla försök till reparation upphäver ansvaret och skyldigheten till garanti och ersättning från tillverkaren.

2012/19/EU (WEEE-direktivet): Produkter som är märkta med denna symbol får inte slängas som osorterat kommunalt avfall inom Europeiska unionen. För korrekt återvinning, returnera denna produkt till din lokala leverantör vid köp av motsvarande ny utrustning, eller kassera den på utsedda samlingsställen. För mer information se: www.recyclethis.info

1.2 Tillämpning

Regulatorn är konstruerad för användning i bostäder, kontorslokaler och industrianläggningar. Kontrollera att installationen överensstämmer med gällande bestämmelser innan den tas i drift för att säkerställa att installationen används på rätt sätt.

2. PRESENTATION

Anslutningsboxen WFC HC RF är speciellt utformad för att styra ditt golvvärme- och kylsystem. Den möjliggör enkel och snabb anslutning av termostater och ställdon. 4 versioner finns tillgängliga:

	230 V Ausführung	24 V Ausführung
6 zoner	SH-CD6-230	SH-CD6-24 (Kräver extern 230V/24V transformator: SH-ST)
10 zoner	SH-CD10-230	SH-CD10-24 (Kräver extern 230V/24V transformator: SH-ST)

2.1 Funktioner

Den har integrerat flera funktioner:

- Vägghalterad eller monterad på DIN-skene.
- Push-in kabelanslutningar med dragavlastning.
- LED-statusindikering och DIP-omkopplare för enhetsinställning.
- Hantera 6 eller 10 zoner med 2 ställdon per zon.
- Enkel sammanslagning av zonerna på samma termostat.
- Konfiguration av flera system.
- H&C ingång (230V och voltfri signal).
- Mätning av vattentemperatur (sond medföljer ej) för fuktdetektering.
- Pump- eller pannutgång (230V och spänningsfri signal).
- Anti-grepphantering.
- kontakt för temperaturbegränsning.
- Intern RF-antenn, extern antenn som tillval.
- Fungerar med NC- och NO-ställdon.
- USB-anslutning för programuppdatering och dataloggning.

2.2 Boxens innehåll



2.3 Första installationen

Det finns 2 sätt att installera styrenheten:

- Vägghontering med 2 skruvar.
- Monterad på en DIN-skena.

3. PRODUKTBESKRIVNING

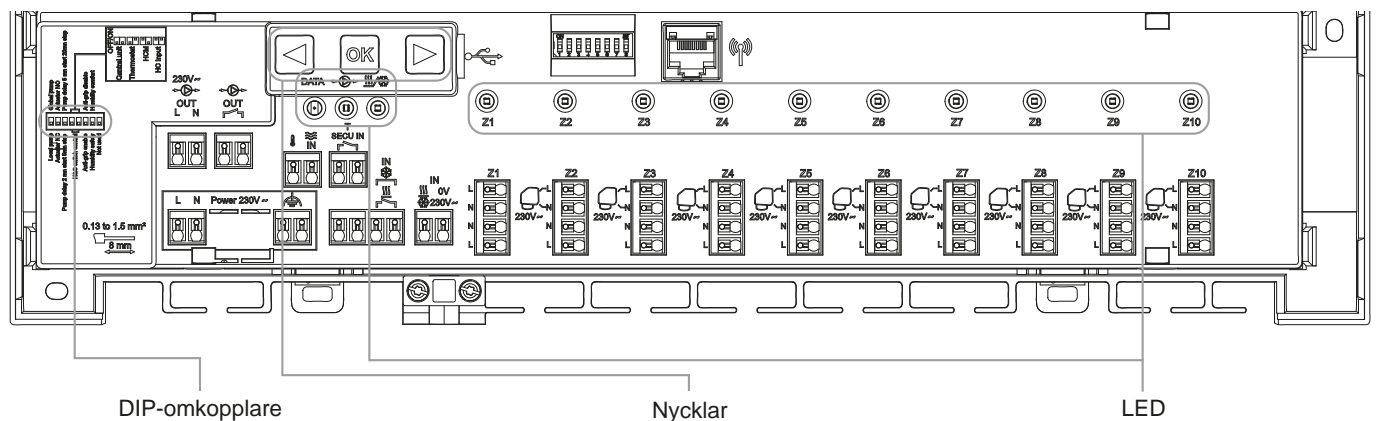

3.1 LED-färgbeteckningar

LED	Betydelse
LED för värme och kyla (röd/blå)	Fixera röd = Uppvärmningsläge. Fix Blå = Kylningsläge. Röd blinkning (vid uppvärmning) eller blå blinkning (vid kylning) = Säkerhetsdetektering Röd / Blå blinkning = RF-förlust (med WFC-03 HC RF, WFC-03 HCM RF 230, BT-CT02 RF, BT-CT03 RF, intern antenn). Vid RF-förlust växlar systemet till uppvärmningsläge.
LED för pump/tork (Grön/Blå/Röd)	Fixera grön = Pumpen är utlöst. Rött blinkande = Systemfel (säkerhetsdetektering / fel på fuktsensor /...) Blått blinkande = Global detektering av luftfuktighet. Blått blinkande = Problem med konfiguration av luftfuktighet.
LED för data (Röd/Grön)	Grönt blinkande = Pågående dataloggning.
LED per zon (Röd/Grön)	Grönt blinkande = RF-överföring/mottagning. Fixera röd = Värme- eller kylbehov i zonen. Rött blinkande = RF-fel med termostaten. Rött blinkar på alla zoner = Fel på RF-antenn. Vid RF-fel med WFC-03 HCM eller BT-CT02 RF växlar systemet till uppvärmningsläge.

3.2 Nycklar

3 kapacitiva tangenter finns tillgängliga.



3.3 Konfiguration av DIP-omkopplare

DIP-Schalter	Funktion	Wert (Standard: OFF)		Konfiguration	Beschreibung
DIP1	Styrenhetens funktion	OFF		Lokal pump	Se 4.3
		ON		Global pump	
DIP2	Typer av ställdon	OFF		NC ställdon	Se 4.6
		ON		NO ställdon	
DIP3	Fördröjning av pumpstart (för det första ställdonet i behov) och fördröjning av ställdonstopp (för det sista ställdonet i behov)	OFF		2min/5min	Se 4.3 och 4.6
		ON		5min/20min	
DIP4 och DIP5	Styrning av H&C-switch	OFF	OFF	Central enhet BT-CT02 RF	Se 4.2
		OFF	ON	Huvudtermostat BT-D03 RF	
		ON	OFF	WFC-03 HCM RF 230	
		ON	ON	WFC-03 HC RF	
DIP6	Anti-grepp	OFF		Aktiverad	Se 6.1
		ON		Funktionshindrad	
DIP7	Hantering av luftfuktighet	OFF		Säkerhetsstrategi	Se 4.5
		ON		Bekvämlighet	
DIP8	Sensor för luftfuktighet	OFF		ON/OFF-sensor	Se 4.5
		ON		Givare för vattentemperatur	

3.4 USB-minne

USB-anslutning möjliggör:

- Att uppdatera programvaran för den personuppgiftsansvarige.
- För att registrera data för systemövervakning (datalog).

För programuppdateringen, se wattswater.eu för att hämta filen, lägg filen på ett USB-minne. Filens namn ska vara WAT-new.mot.

- Sätt i USB-minnet i styrenheten.
- Koppla till/från regulatorn.
- Under uppdatering,
 - Grön LED är strömmen på från Z1 till Z6/Z10
 - Alla lysdioder blir röda
 - Röd LED är avstängd från Z6/Z10 till Z1
- Efter uppdateringen kan du ta bort USB-minnet.

För felsökning är datalog användbar för att registrera data i en ASCII-fil som lagras på USB-dongeln för felsökning.

Genom att trycka på i 5 sekunder går mastern till menyn Funktioner. Lysdioden för den första zonen blinkar antingen rött (datalogning är aktiverad) eller grönt (datalogning är avaktiverad). Du kan aktivera eller inaktivera datalogen genom att klicka på .

Långt tryck på gör det möjligt att lämna funktionsmenyn (annars finns det en timeout på 10 sekunder innan funktionsmenyn automatiskt lämnas)

1 loggfil skapas var 14:e dag. I filen görs en registrering var 10:e minut.

4. INGÅNGAR/UTGÅNGAR

4.1 Strömförsörjning

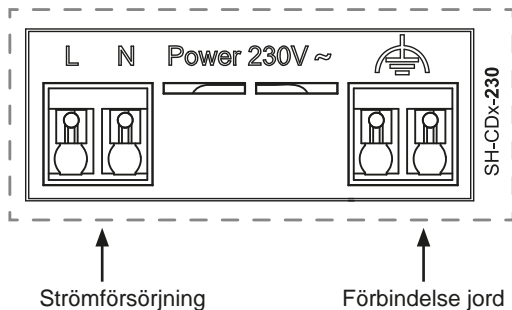

Kräver användning av transformator som levereras av Watts (4 kablar): SH-ST

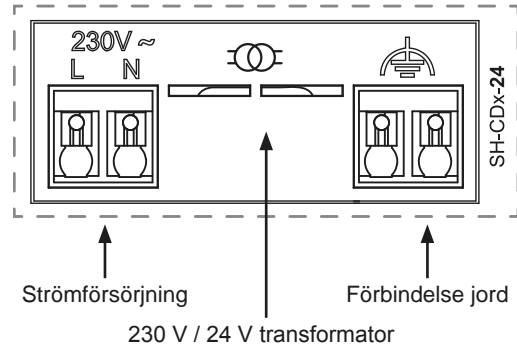

4.2 Ingång för uppvärmning/kyllning (H&C)

Syfte:

Denna ingång gör det möjligt att växla regleringsläge för systemet: Värme eller kyla.

Signalens källa:

- En mekanisk omkopplare
- En värmepump
- En BT-WR02 RF kopplas till BT-CT02 RF-centralenheten som en ON/OFF-enhet. Denna lösning gör det möjligt att fjärrstyra H&C-läget från applikationen.

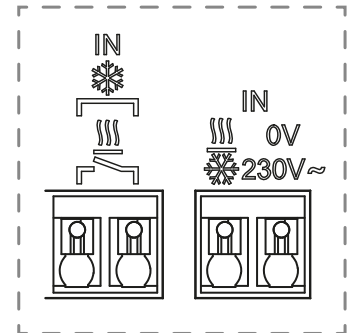

Signalens format: Inmatningen kan vara fri kontakt eller spänningssatt kontakt 230V.

Läge	Fri kontakt	Live kontakt
Uppvärmning	Öppnad	Ingen signal
Kyllning	Stängt	230Vac

Endast en enhet i systemet ska kunna välja H&C-läge. Andra möjliga signalkällor för H&C-omkopplare (se 3.3)

- Centralenhet (ställ in manuellt H&C läge i centralenhetens installatörsmeny) DIP4/DIP5 = OFF/OFF.
- WFC-03 HCM RF 230 som innehåller en H&C ingång DIP4/DIP5 = ON/OFF.
- Digital termostat konfigurerad som en Master H&C termostat i manuellt eller automatiskt läge (endast en termostat per installation) DIP4/DIP5 = OFF/ON.

Om du har flera anslutningsboxar WFC-03 HC RF i systemet, bör H&C-läget styras av endast en styrenhet:

- Utan central betraktar systemet den anslutande boxen som Main WFC-03 HC RF (se 5.1.2) DIP4/DIP5 = ON/ON.
- Med central:
 - Om kopplingsboxen styr H&C-läget är DIP4/DIP5 = ON/ON.
 - Om centralenheten styr H&C-läget är DIP4/DIP5 = OFF/OFF.

DIP4	DIP5	Omkopplingssignal H&C begäran av
OFF	OFF	Central enhet (BT-CT02 RF)
OFF	ON	Termostat
ON	OFF	Modul för värme och kyla (WFC-03-HCM RF 230)
ON	ON	Anslutningsbox (WFC-03 HC RF)

4.3 Pumputgång

Det finns 2 utgångar:

- Utgång för strömförande kontakt (230Vac)
- Fri kontaktutgång

Dessa utgångar kan användas för att trigga:

- En zonventil
- En pump
- En värmepanna eller värmepump

De 2 utgångarna aktiveras när det finns ett värme- eller kylbehov (se 3.3):

- I styrenheten om DIP-switch 1 = OFF = lokal
- I systemet om DIP-omkopplare 1 = ON = global

Fördröjningen mellan värme- eller kylbehovet och pumpaktiveringen är konfigurerbar: (se 3.3).

- Pumpen startar 2 minuter efter värme- eller kylbehov om DIP-omkopplare 3 = OFF
- Pumpen startar 5 minuter efter värme- eller kylbehov om DIP-omkopplare 3 = ON

Syftet är att ta hänsyn till ställdonets latens.

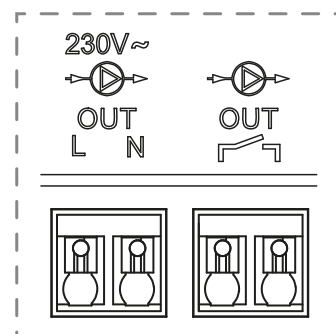

4.4 Kontakt för temperaturbegränsning

Detta är en säkerhetsingång (fri kontakt).

Stängd kontakt	Öppnad kontakt
Ingen säkerhetsdetektering	Avkänning av överhettning eller överkylning

Säkerhetsingången bör användas på en styrenhet med en pump.

När kontakten öppnas:

- Den lokala pumputgången stoppas (även om DIP1=ON, dvs. global pump på regulatorn).
- Ställdonen är stängda.
- Lysdioden för pump/tork blinkar rött.
- LED-lampan för värme och kyla blinkar rött (vid uppvärmning) eller blått (vid kylning).
- Om regulatorn är en underregulator skickas inte värme- eller kylbehovet till huvudregulatorn.

Du kan använda en kontakttermostat för termisk säkerhet. Du kan installera 2 kontakttermostater i serie för att skydda mot både överhettning och överkylning (säkerhetsingången är giltig i både värme- och kyläge).

Produkten levereras med en rem på kontakten.

Observera att pumpen i WFC-03 HCM RF 230 aktiveras när minst en pump i de flera WFC-03 HC RF som är installerade i systemet aktiveras.

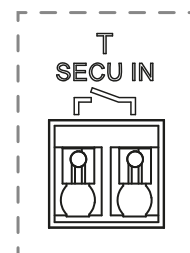

4.5 Ingång för detektering av luftfuktighet

Produkten har en ingång för fuktdetektering.

2 möjliga typer av signaler enligt DIP8 (se 3.3):

- En kontaktgivare för fuktighet.
- Vattentemperaturgivare (CTN 10kΩ): Krav på BT-D03 RF RH-termostat.

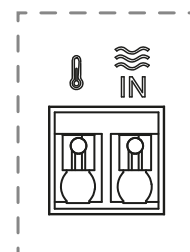

4.5.1 Kontaktgivare för luftfuktighet (daggpunktsstyrning)

DIP8 = OFF

Signalens format: Inmatningen är en fri kontakt.

Ingen luftfuktighet	Luftfuktighet detekterad
Öppnad kontakt	Sluten kontakt

I kyläge, när luftfuktighet detekteras, styrs regulatorn:

- Stoppar pumpsignalen.
- Stänger alla ställdon.
- Skickar fuktlarmet till alla andra WFC-03 HC RF i systemet.
- Begär att WFC HCM RF ska aktivera avfuktaren.

Om regulatorn är en underregulator skickas inte kylbehovet till huvudregulatorn.

4.5.2 Givare för vattentemperatur

DIP8 = ON

Det finns 2 användningsområden för mätning av vattentemperatur.

Detektering av luftfuktighet

I kyläge beräknar regulatorn daggpunkten för varje zon baserat på omgivningstemperaturen och den relativa fuktigheten som skickas av varje termostat (termostat med sensor för relativ fuktighet krävs).

När vattentemperaturen når daggpunkten i en zon aktiveras regulatorn:

Säkerhetsstrategi DIP7 = OFF	Bekvämlighet DIP7 = ON
Stäng zonen ställdon och stoppa zonen kylbehov.	Håll zonen ställdon öppet i en timme, stäng sedan ställdonet och stoppa kylbehovet i zonen om fuktlarmet fortfarande utlöses.

- Aktivera fjärrstyrd avfuktning av zonen.
- Begär att värme- och kylmodulen WFC-03 HCM RF 230 aktiverar den globala avfuktaren under minst 15 minuter och att larmet försvinner om ingen fjärrstyrd avfuktare finns tillgänglig i zonen.

Om regulatorn är en underregulator skickas inte zonen kylbehov till huvudregulatorn.

Detektering av uppvärmnings- och kylningsläge

När DIP4 = ON och DIP5 = ON (H&C switch control = WFC-03 HC RF) och DIP8 = ON används vattentemperaturen för att automatiskt detektera H&C läget.

- Om vattentemperaturen är > 24°C är systemet i uppvärmningsläge.
- Om vattentemperaturen är < 20°C är systemet i kylningsläge.

Denna funktion är användbar när värmepumpen automatiskt växlar till värme- eller kyläge och inte har någon utgång för att informera systemet.

- Om WFC-03 HCM RF 230 mäter en vattentemperatur:
Temperaturen skickas till WFC-03 HC RF som kan användas om det inte finns någon vattentempersensor.
- Om H&C ingång = kyläge: Systemet växlar till kyläge oavsett vattentemperatur.

4.6 NC/NO ställdon

Anslut ett NC- eller NO-ställdon per kontaktdon.

- 230V ställdon för WFC-03 HC RF 230
- 24V ställdon för WFC-03 HC RF 24

Typen av ställdon definieras av DIP2.

Det är nödvändigt att använda samma typ för alla ställdon.

När det finns ett värme- eller kylbehov i en zon utlöses ställdonet omedelbart. När värme- eller kylbehovet stoppas stängs ställdonet omedelbart, utom om detta är det sista ställdonet som öppnats i regulatorn. I det fallet är fördröjningen innan ställdonet börjar stängas beroende av DIP3 (se 3.3):

- Om DIP3 = OFF, väntar systemet 5 min innan det sista ställdonet stängs
- Om DIP3 = ON, väntar systemet 20 min innan det sista ställdonet stängs

Motivering: Många värmepumpar har en inbyggd avstängningsfördröjning (för att undvika successiv OFF/ON). I detta fall fortsätter värmepumpen att gå i x minuter utöver den faktiska frånkopplingstiden. Det är viktigt att hålla minst en krets öppen om det inte finns en bufferttank, hydraulbrytare eller bypass i installationen.

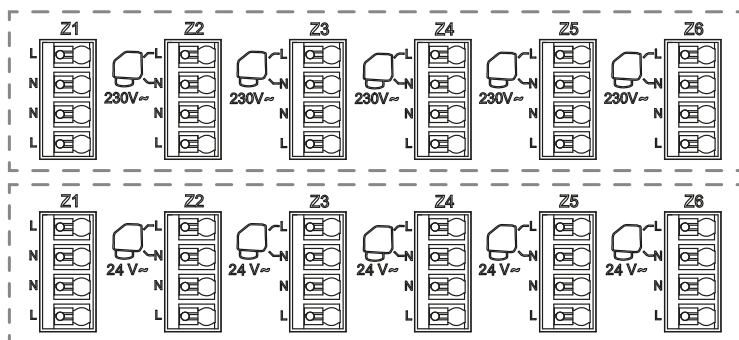

4.7 Extern antenn

Styrenheten har en inbyggd intern antenn.

Vid behov kan en extern antenn anslutas för att förbättra RF-kommunikationen. Det kan vara användbart om styrenheten är installerad i en metallbox. I så fall måste du installera den externa antennen utanför metallboxen.

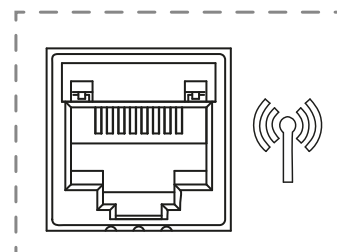

Vänligen respektera monteringen för att optimera känsligheten och undvika dysfunktion.

Antenn måste vara installerad:

- utanför den metalliska boxen
- i vertikalt läge
- och minst 50 cm från metalldelar.

Om du har flera antenner (flera styrenheter) måste de placeras på minst 80 cm avstånd från varandra.

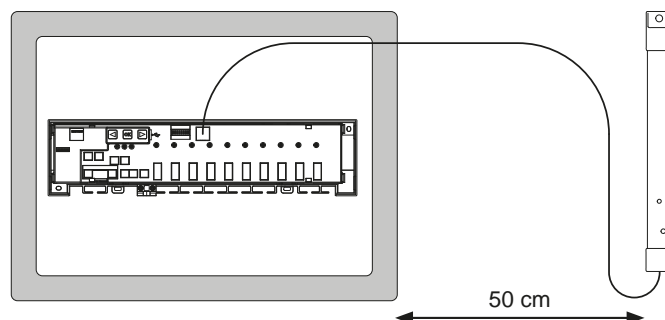



5. Systemkonfiguration

5.1 Systemkonfiguration utan centralenhet

5.1.1 Fristående installation

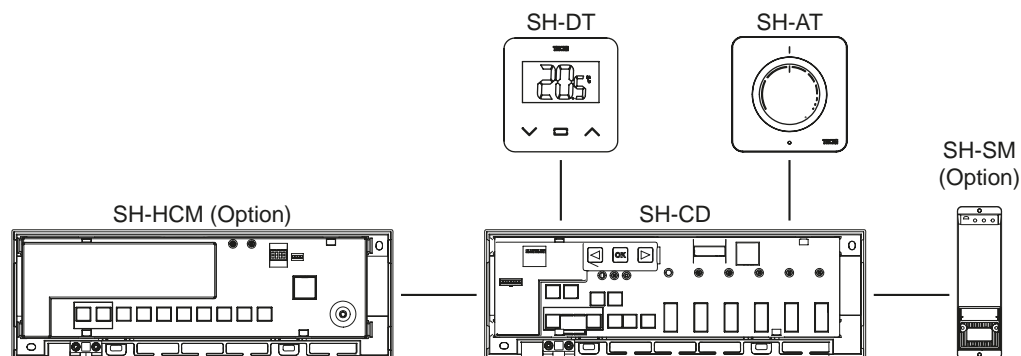
Endast en styrenhet eller flera styrenheter utan sammankoppling.

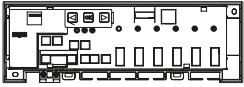
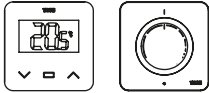
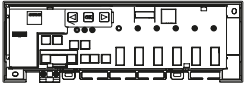
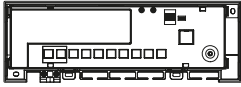
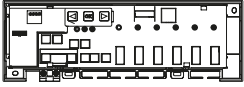

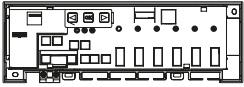
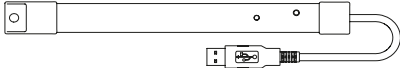
Gerät 1	Gerät 2	Bemerkungen
 <p>Genom att trycka på OK i 5 sekunder går styrenheten till RF-parningsläge. Välj zon 1 med ◀ eller ▶ (LED:n blinkar rött), tryck på OK för att gå till läget Para ihop med termostat. En grön blinkande LED är en positionsindikator. Flytta den grönt blinkande LED:n med ◀ eller ▶ för att välja den eller de zoner som ska paras ihop. Välj/avmarkera zon med OK. Vald zon lyser rött men fortsätter att blinka grönt (positionsindikator). Redan ihopkopplad zon är fix green.</p>	 <p>Termostater: Ställ in produkten i RF-parningsläge (se motsvarande bruksanvisning).</p>	<p>Om RF-parning har utförts måste lysdioderna för de zoner som valts på WFC-03 HC RF släckas och termostaterna måste lämna parningsläget. För att parkoppla en annan termostat måste du gå in i/starta läget igen. Avsluta styrenhetens kopplingsläge: Tryck länge på ◀.</p>
 <p>Genom att trycka på OK i 5 sekunder går styrenheten till RF-parningsmenyn. Välj zon 3 med ◀ eller ▶ (LED:n blinkar rött), tryck på OK för att gå till läget Para ihop med en slavenhet. Alla lysdioder blinkar grönt.</p>	 <p>Ställ in enheten på RF-kopplingsläge. Tryck på knappen i 10 sekunder. För ytterligare information, se bruksanvisningen för respektive enhet.</p>	<p>När länken är klar återgår WFC-03 HC RF till kopplingsläge och WFC-03 HCM RF 230 återgår till normalläge. Avsluta styrenhetens kopplingsläge: Tryck länge på ◀. OBSERVERA: endast en värme-kylmodul WFC-03 HCM RF 230 per installation.</p>
 <p>Genom att trycka på OK i 5 sekunder går styrenheten till RF-parningsmenyn. Välj zon 3 med ◀ eller ▶ (LED:n blinkar rött), tryck på OK för att gå till läget Para ihop med en slavenhet. Alla lysdioder blinkar grönt.</p>	 <p>Ställ in BT-WR02 RF på RF-kopplingsläge. Tryck på knappen i 5 sekunder. För ytterligare information, se bruksanvisningen för enheten.</p>	<p>När länken är klar lämnar BT-WR02 RF kopplingsläget. WFC-03 HC RF återgår till kopplingsläge. Avsluta styrenhetens kopplingsläge: Tryck länge på ◀.</p>
 <p>Genom att trycka på OK i 5 sekunder går styrenheten till RF-parningsmenyn. Välj zon 3 med ◀ eller ▶ (LED:n blinkar rött), tryck på OK för att gå till läget Para ihop med en slavenhet. Alla lysdioder blinkar grönt.</p>	 <p>Ställ in BT-RPT02 RF på RF-kopplingsläge. Tryck på knappen i 3 sekunder. För ytterligare information, se bruksanvisningen för enheten.</p>	<p>Wenn die Verbindung hergestellt ist, beendet SH-R den Kopplungsmodus. Die LED leuchtet dauerhaft grün. SH-CD kehrt dagegen in den Kopplungsmodus zurück. Verlassen des RF-Kopplungsmodus: Drücken Sie lange auf ◀.</p>

5.1.2 Installation av flera styrenheter

Om det finns flera sammankopplade styrenheter i installationen, finns det 1 huvudstyrenhet (Main WFC-03 HC RF) och upp till 3 understyrenheter (Sub WFC-03 HC RF).

Huvudstyrenheten centraliserar informationen för understyrenheterna. Om en värmekylmodul WFC-03 HCM RF 230 används, bör den kopplas till huvudregulatorn.

- Huvudstyrenheten överför värme- och kylåtgärden till understyrenheterna. Denna information kan komma från WFC-03 HCM RF 230 eller från en Master Digital-termostat enligt DIP4 och DIP5 (se 3.3)
- Huvudstyrenheten kan hantera pumphjulsignalen för hela installationen enligt DIP1 (se 3.3)

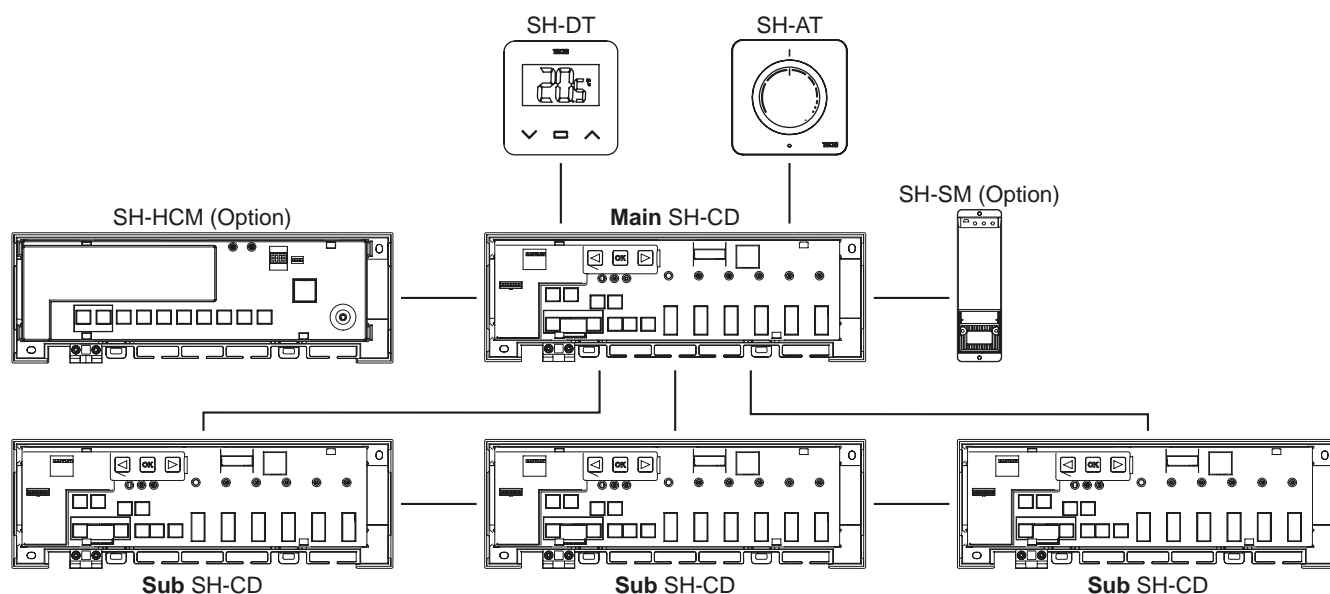

Enhet 1: Huvudkontrollenhet	Enhet 2: Underkontrollant	Anmärkningar
Först måste alla radiotermostater paras ihop med respektive WFC-03 HC RF-regulator! Se 5.1.1		
<p>Genom att trycka på OK i 5 sekunder går styrenheten till RF-parningsmenyn.</p> <p>Välj zon 3 med ◀ eller ▶ (LED:n blinkar rött), tryck på OK för att gå till läget Para ihop med en slavenhet. Alla lysdioder blinkar grönt.</p>	<p>Genom att trycka på OK i 5 sekunder går styrenheten till RF-parningsmenyn.</p> <p>Välj zon 2 med ◀ eller ▶ (LED:n blinkar rött), tryck på OK för att gå till läget Para ihop med en huvudenhet. Alla lysdioder blinkar rött.</p>	<p>När RF-parningen är klar återgår både WFC-03 HC RF till parningsläge.</p> <p>Avsluta menyn för parkoppling av styrenheter: Tryck länge på ◀.</p>

5.2 Systemkonfiguration med centralenhet

Centralenheten centraliserar kommunikationen mellan styrenheterna.

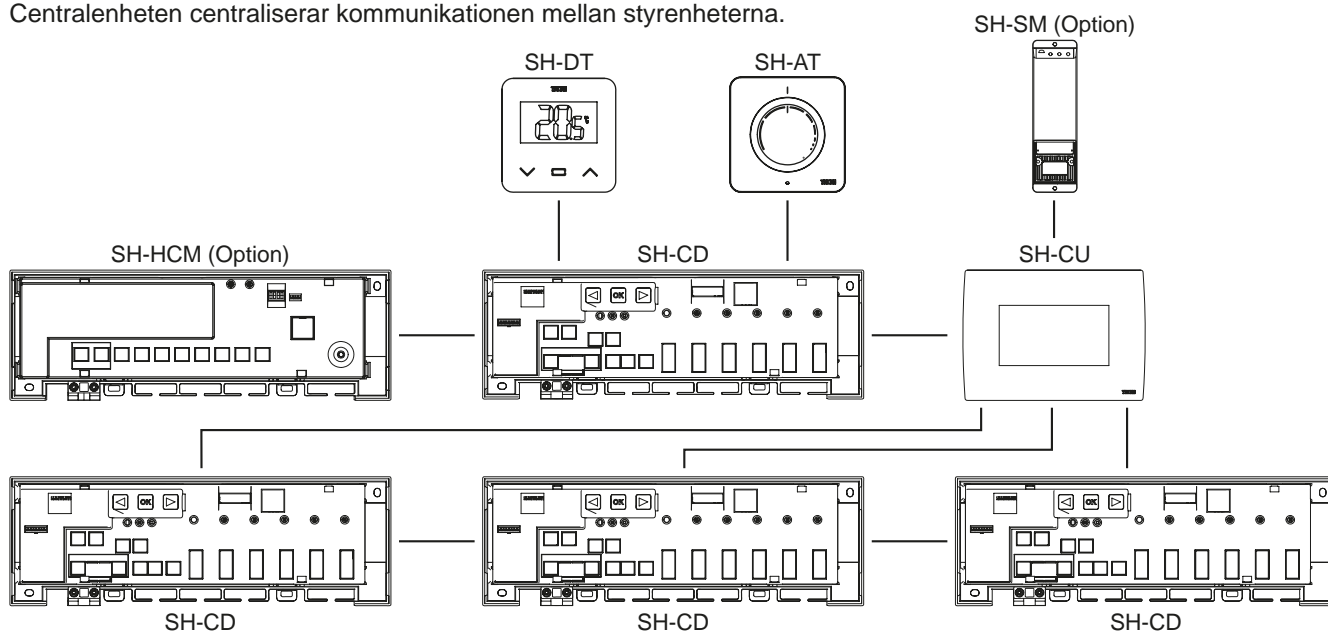

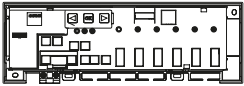
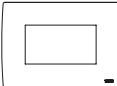
Enhet 1: SH-CD	Enhet 2: SH-CU	Anmärkningar
Först måste alla radiotermostater paras ihop med respektive WFC-03 HC RF-regulator! Se 5.1.1		
 <p>Genom att trycka på OK i 5 sekunder går styrenheten till RF-parningsmenyn. Välj zon 2 med ◀ eller ▶ (LED:n blinkar rött), tryck på OK för att gå till läget Para ihop med en huvudenhet. Alla lysdioder blinkar rött.</p>	 <p>Sätt enheten i RF-parningsläge. Välj ett rum (Rum 1). Vid parning av WFC-03 HC RF med CT-02 RF genereras ett rum för varje trådlös termostat. Rummen får därför inte skapas i centralenheten i förväg.</p>	<p>När RF-parningen är klar lämnar både WFC-03 HC RF och BT-CT02 RF parningsläget. Avsluta menyn för parkoppling av styrenheter: Tryck länge på ◀.</p>

5.3 Styr en avfuktare per rum.

Det finns 2 sätt att mäta luftfuktighet:

- På regulatornivå med hjälp av ingången för fuktdetektering (se 4.5).
- På rumsnivå om termostaten har en sensor för relativ luftfuktighet.

När luftfuktighet detekteras finns det 2 sätt att aktivera avfuktaren:

- En global avfuktare aktiveras av WFC-03 HCM RF 230 om funktionen är aktiverad på WFC-03 HCM RF 230.
- En avfuktare aktiveras på den rumsnivå där luftfuktigheten detekteras. I så fall måste du para ihop en BT-WR02 RF-mottagare på varje zon i styrenheten för att trigga en avfuktare.

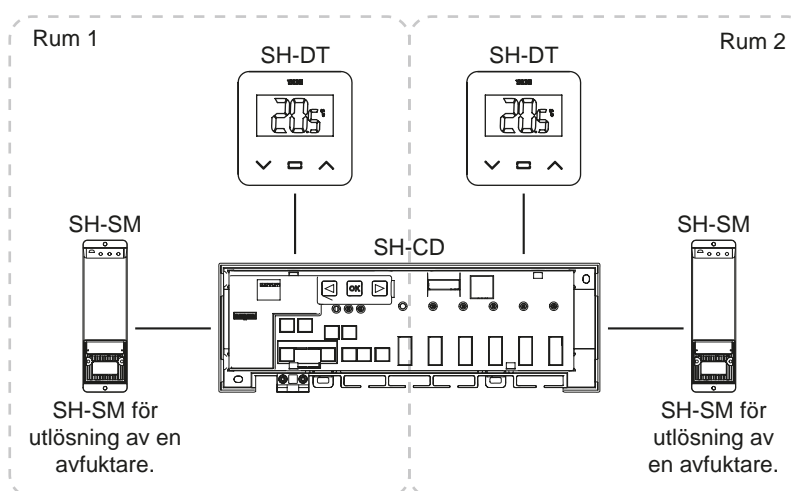

Enhe 1: SH-CD	Enhe 2: SH-SM	Anmärkningar
<p>Genom att trycka på i 5 sekunder går styrenheten till RF-parningsmenyn.</p> <p>Använd eller för att välja zon 4 (LED:n blinkar rött), tryck på för att gå in i parningsläge för avfuktare.</p> <p>Välj zoner med eller .</p> <p>Zoner definieras av parade termostatkanaler.</p> <p>Till exempel: TH1 = Z1, TH2 = Z2+Z3 och TH3 = Z4+Z5+Z6. Navigeringen föreslår 3 zoner för att koppla en avfuktare till (Z1), (Z2+Z3) och (Z4+Z5+Z6).</p> <p>Välj/avmarkera zon med . (Du kan endast välja en zon per avfuktare). Markören blinkar grönt.</p> <p>Vald zon blinkar rött och grönt</p> <p>Redan ihopkopplad zon är fix green.</p> <p>(För att ta bort en avfuktare, välj en zon i grönt och tryck sedan samtidigt på och up för att få zonen att blinka i grönt)</p>	<div style="text-align: center;">  </div> <p>Ställ in BT-WR02 RF på RF-kopplingsläge.</p> <p>Tryck på knappen i 5 sekunder.</p> <p>För ytterligare information, se bruksanvisningen för enheten.</p>	<p>När länken är klar lämnar BT-WR02 RF kopplingsläget. WFC-03 HC RF återgår till kopplingsläge.</p> <p>Avsluta styrenhetens kopplingsläge: Tryck länge på .</p>

6. Andra egenskaper

6.1 Anti-grepp-funktion

Funktionen aktiveras med DIP6 (se 3.3). Om ventilerna inte är aktiva under en vecka utlöses en fullständig motionering (ställdon + pumputgångar + värme-/kylbehov skickas till WFC-03 HCM RF 230).

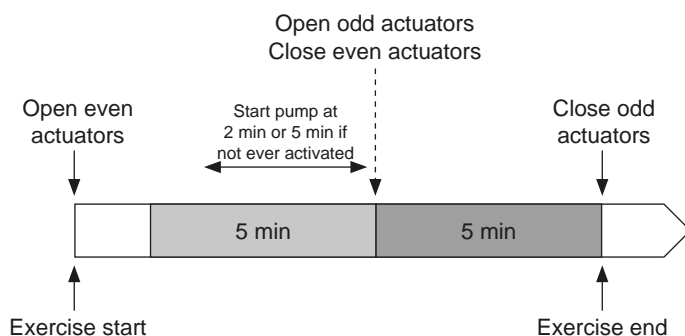

6.2 Återställ

Vid funktionsstörningar kan det vara nödvändigt att återställa produkten till fabriksinställningarna.

Genom att trycka på i 5 sekunder går mastern till Reset-menyn. LED för zon 1 börjar blinka rött, övriga zoners LED börjar blinka grönt.

Tryck sedan samtidigt på , och tills alla zoners LED-lampor lyser rött, styrenheten återställs och produkten startas om. LED-lamporna släcks.

6.3 Felsökning

Symptom	Problem	Beskrivning	Felsökning
Röd eller blå blinkning på LED för värme och kyla och Röd blinkning på Pump/ Tork LED	Säkerhetsdetektering	Kontakten för säkerhetsingången öppnas	Om du inte använder en säkerhetstermostat, se till att du har installerat en rem på säkerhetstermostatens ingång. Kontrollera annars rörets temperatur (för varmt i uppvärmningsläge, för kallt i kylningsläge)
Röd/blå blinkning på LED för värme och kyla	RF-frågan	Styrenheten har förlorat anslutningen till en annan RF-enhet än en termostat	enheterna. Om styrenheten är installerad i en metallbox, använd en extern antenn som är placerad utanför metallboxen. En RF-repeater kan behövas.
Snabb blå blinkning på Pump/Tork LED	Problem med konfiguration av luftfuktighet	NTC-mätning på H&C ingång medan DIP8 = OFF. ON/OFF-ingång på H&C-ingång medan DIP8 = ON	Kontrollera om NTC-sensor och DIP-omkopplarens inställning
Rött blinkande på 1 zon	RF-fel med termostaten	Styrenheten har förlorat förbindelsen med termostaten.	Kontrollera avståndet mellan regulatoren och termostaten. En RF-repeater kan behövas.
Rött blinkande på alla zoner	Fel på RF-antenn	Regulatoren har förlorat alla RF-anslutningar (termostat och andra enheter)	Extern antenn kan behövas.

7. TEKNISKA EGENSKAPER

7.1 Technische Daten

	SH-CD6-24, SH-CD6-230, SH-CD10-24, SH-CD10-230
Elektriskt skydd	Klass II med funktionell jord
IP-skydd	IP30
Transport- och lagringstemperatur	-10 °C till 50 °C (14 °F till 122 °F)
Strömförsörjning	230 V AC ± 10 % 50 Hz
Utgångens maximala belastning (2 utgångar)	Relä: 5 A
Ställdon	230 V / 24 V NC / NO upp till 2 W
Kompatibilitet	SH-AT, SH-DT, SH-DTP, SH-HCM, SH-CU, SH-SM

7.2 Mått och vikt

SH-CD6-24 und SH-CD6-230:

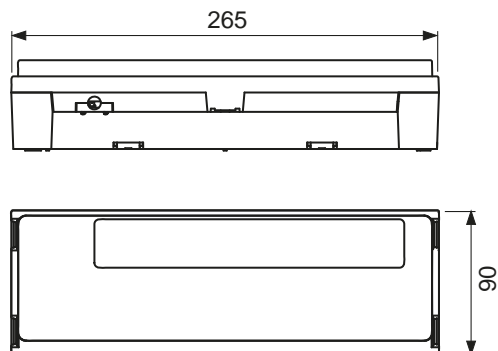

SH-CD10-24 und SH-CD10-v230:

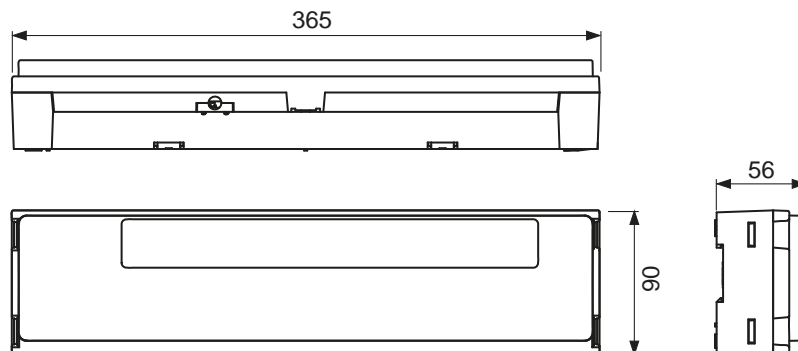

Gewicht: 840 g - SH-CD6
940 g - SH-CD10

8. DIREKTIV

Beteckning	Beskrivning	Länk
Lågspänningsdirektivet (LVD)	Lågspänningsdirektivet (LVD) (2014/35/EU) säkerställer att elektrisk utrustning inom vissa spänningsgränser ger en hög skyddsnivå för europeiska medborgare, och drar full nytta av den inre marknaden.	2014/35/UE
Elektromagnetisk kompatibilitet (EMC) Direktiv 2014/30/EU	Direktivet om elektromagnetisk kompatibilitet (EMC) 2014/30/EU säkerställer att elektrisk och elektronisk utrustning inte genererar, eller påverkas av, elektromagnetisk störning.	2014/30/UE
Begränsning av användningen av vissa direktivet om farliga ämnen (RoHS) 2011/65/EU	Direktiv om begränsning av användningen av vissa farliga ämnen i elektriska och elektroniska utrustning.	2011/65/EU
Elektriskt avfall & Elektronisk utrustning Direktiv (WEEE)	WEEE-direktivet (2012/19/EU) syftar till att minska mängden avfall från elektrisk och elektronisk utrustning som hamnar på deponi.	2012/19/EU
Kommissionen för ekodesign Förordning	Ekodesignkrav för rumsvärmare.	2015/1188
Direktiv om radioutrustning (RED) 2014/53/EU	I radioutrustningsdirektivet 2014/53/EU (RED) fastställs ett regelverk för utsläppande av radioutrustning på marknaden.	2014/53/EU

Sadržaj

1. OPĆE INFORMACIJE	116
1.1 Sigurnosne upute i upute za rad	116
1.2 Primjena	116
2. PREZENTACIJA	116
2.1 funkcije	116
2.2 opseg isporuke	117
2.3 Prva instalacija	117
3. OPIS PROIZVODA	117
3.1 Značenja LED boja (Crvena oznaka)	117
3.2 Gumbi (zelena oznaka)	117
3.3 Konfiguracija DIP sklopke (narančasta oznaka)	118
3.4 USB stick	118
4. ULAZI / IZLAZI	119
4.1 Spannungsversorgung	119
4.2 grijanje / hlađenje (H&C) ulaz	119
4.3 pumpa Izlaz	120
4.4 Kontakt za ograničenje temperature	120
4.5 Ulaz za detekciju vlažnosti	120
4.6 NC/NO aktuatori	121
4.7 Vanjska antena	122
5. konfiguracija sustava	122
5.1 Konfiguracija sustava bez centralne jedinice	122
5.2 Konfiguracija sustava s centralnom jedinicom	125
5.3 Kontrola jednog odvlaživača po prostoriji.	125
6. Više značajki	126
6.1 Anti-Grip funkcija	126
6.2 Vрати na zadano	126
6.3 rješavanje problema	127
7. TEHNIČKE KARAKTERISTIKE	127
7.1 Tehnički podaci	127
7.2 mjere i težinu	128
8. POLITIKE	128

1. OPĆE INFORMACIJE

1.1 Sigurnosne upute i upute za rad

Poželjno je da ovaj proizvod instalira kvalificirani stručnjak. Uz poštivanje gore navedenih uvjeta, proizvođač prihvaća odgovornost za uređaj u okviru zakonskih odredbi. Prilikom rada s regulatorom potrebno je pridržavati se svih uputa u ovim uputama za montažu i rad. Pogreške uzrokovane nepravilnom instalacijom, nepravilnom uporabom ili nedostatkom održavanja poništavaju odgovornost proizvođača.



Svaki pokušaj popravka oslobađa vas odgovornosti i obveze jamstva i zamjene od strane proizvođača. 2012/19/EU (WEEE Direktiva): Proizvodi označeni ovim simbolom ne smiju se odlagati kao nerazvrstani komunalni otpad u Europskoj uniji. Za pravilno recikliranje, kada kupujete novi ekvivalentni proizvod, vratite ovaj proizvod svom lokalnom dobavljaču ili ga odložite na određenim sabirnim mjestima. Za više informacija pogledajte: www.stiftung-ear.de.

1.2 Primjena

Kontroler je dizajniran za korištenje u dnevnim sobama, uredima i industrijskim pogonima. Prije pokretanja provjerite je li instalacija u skladu s važećim propisima kako biste osigurali pravilnu upotrebu sustava.

2. PREZENTACIJA

SH-CD priključna kutija posebno je dizajnirana za upravljanje vašim površinskim grijanjem i hlađenjem. Omogućuje brzo i jednostavno spajanje termostata i aktuatora. Dostupne su 4 verzije:

	230 V izvršenje	24 V verzija
6 zona	SH-CD6-230	SH-CD6-24 (potreban je vanjski 230 V / 24 V transformator SH-ST)
10 zona	SH-CD10-230	SH-CD10-24 (potreban je vanjski 230 V / 24 V transformator SH-ST)

2.1 funkcije

Ima nekoliko integriranih funkcija:

- Montaža na zid ili nosač na DIN šinu
- Utični kabelski priključci s rasterećenjem naprezanja
- LED prikaz statusa i DIP prekidači za podešavanje uređaja
- Upravljanje sa 6 ili 10 zona s 2 aktuatora po zoni
- Jednostavno grupiranje zona na istom termostatu
- Konfiguracija više sustava
- H&C ulaz (230 V i signal bez napona)
- Mjerenje temperature vode (sonda nije uključena) za detekciju vlažnosti
- Izlaz pumpe ili kotla (230 V i signal bez napona)
- Anti-Grip upravljanje
- Kontakt za ograničenje temperature
- Unutarnja radio antena, dodatna vanjska antena
- Radi s NC i NO aktuatorima
- USB priključak za ažuriranje softvera i snimanje podataka

2.2 opseg isporuke



2.3 Prva instalacija

Postoje 2 načina za instaliranje razdjelnika upravljanja:

- Montaža na zid s 2 vijka.
- Postavljen na gornju šinu 35 x 7,5 (DIN EN 60715).

3. OPIS PROIZVODA

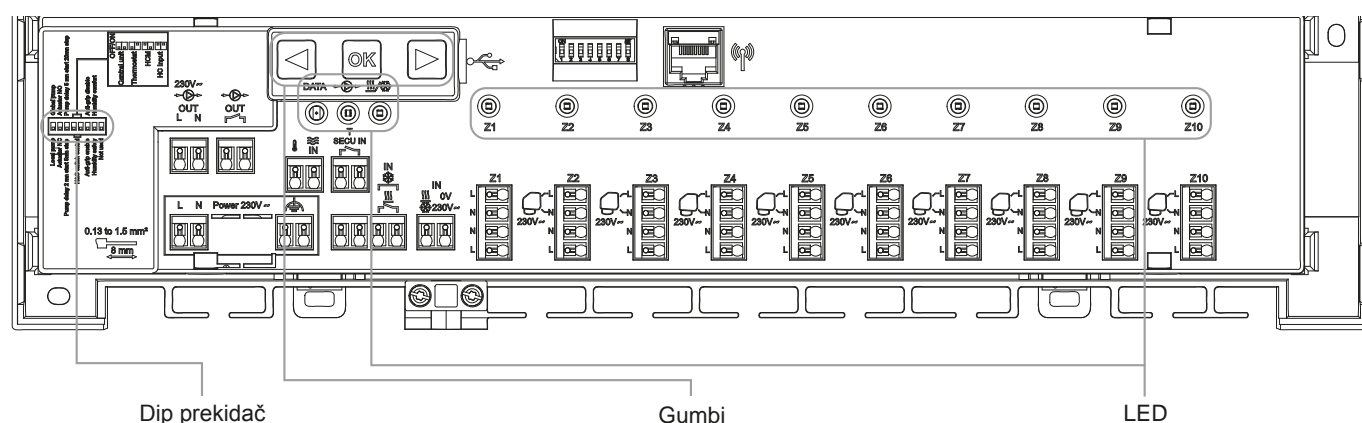

3.1 Značenja LED boja (Crvena oznaka)

LED diode	Značenje
LED grijanje i hlađenje (crveno/plavo)	Fiksno crveno = način grijanja. Fiksno plavo = rad hlađenja. Trepće crveno (pri zagrijavanju) ili Treperi plavo (kada se hladi) = sigurnosna detekcija. Trepere crveno/plavo= RF gubitak (s SH-CD, SH-HCM, SH-CU, unutarnja antena). U slučaju gubitka RF, sustav se prebacuje u način rada grijanja.
LED pumpa / odvlaživač (Zelena/plava/crvena)	Popravi Zeleno = Pumpa je pokrenuta. Trepće crveno = greška sustava (sigurnosna detekcija / greška senzora vlage/...) Trepćuće plavo = otkrivanje globalne vlažnosti. Treperenje plavo = Problem s mokrom konfiguracijom.
LED evidencija podataka (crveno zelena)	Trepće zeleno = Zapisivanje podataka u tijeku.
LED po zoni (Crveno/ zeleno)	Trepće zeleno = RF slanje/prijem. Popravi crveno = zahtjev za grijanje ili hlađenje u zoni. Trepće crveno = RF pogreška Spajanje na termostat. Trepće crveno u svim zonama = greška RF antene. U slučaju gubitka RF-a s SH-CD HCM ili SH-CU, sustav se prebacuje na način grijanja.

3.2 Gumbi (zelena oznaka)

Dostupna su 3 kapacitivna gumba (osjetljiva na dodir).



3.3 Konfiguracija DIP sklopke (narančasta oznaka)

Dip prekidač	funkcija	Vrijednost (Zadano: OFF)		Konfiguration	Beschreibung
DIP1	Uključite pumpu zahtjeva	OFF		OFF	Vidi 4.3
		ON		ON	
DIP2	vrsta aktuatora	OFF		OFF	Vidi 4.6
		ON		ON	
DIP3	Odgoda pokretanja pumpe (za prvi zatražen pogon) i odgoda zaustavljanja pogona (za posljednji zatražen pogon)	OFF		OFF	Vidi 4.3 i 4.6
		ON		ON	
DIP4 / DIP5	Preklopni signal grijanje/ hlađenje, zahtjev od:	OFF	OFF	centralna jedinica BT-CT02 RF	Vidi 4.2
		OFF	OFF	Glavni termostat BT-D03 RF	
		ON	ON	Modul grijanje-hlađenje WFC-03 HCM RF 230	
		ON	ON	Priključni blok WFC-03 HC RF	
DIP6	Anti-Grip (zaštita od zapinjanja pumpe i ventila)	OFF		OFF	Vidi 6.1
		ON		ON	
DIP7	upravljanje vlagom	OFF		OFF	Vidi 4.5
		ON		ON	
DIP8	senzor vlažnosti	OFF		OFF	Vidi 4.5
		ON		ON	

3.4 USB stick

USB povezivanje omogućuje :

- Ažuriranje softvera kontrolera .
- Snimanje podataka za nadzor sustava (datalog) .

Ažuriranje softvera dostupno je na tece.com, datoteku spremite na USB memoriju.

- Umetnite USB stick u kontroler.
- Isključite/uključite regulator.
- tijekom ažuriranja,
 - Zelene LED diode pale se od Z1 do Z6/Z10
 - Sve LED diode svijetle crveno
 - Crvene LED diode se gase od Z6/Z10 do Z1
- Nakon ažuriranja možete izvaditi USB stick.

Datalog je koristan za rješavanje problema. Podaci se spremaju u ASCII datoteku na USB stick.

Pritiskom na 5 sekundi upravljač se vraća u izbornik funkcija. LED dioda prve zone treperi ili crveno (datalog je omogućen) ili zeleno (datalog je onemogućen).

Možete omogućiti ili onemogućiti zapisivač podataka pritiskom na . Dugi pritisak na omogućuje izlazak iz izbornika funkcija (inače postoji vremensko ograničenje od 10 s prije nego se automatski izađe iz izbornika funkcija).

Dnevnik se kreira svakih 14 dana. Svakih 10 minuta unosi se u datoteku.

4. ULAZI / IZLAZI

4.1 Spannungsversorgung

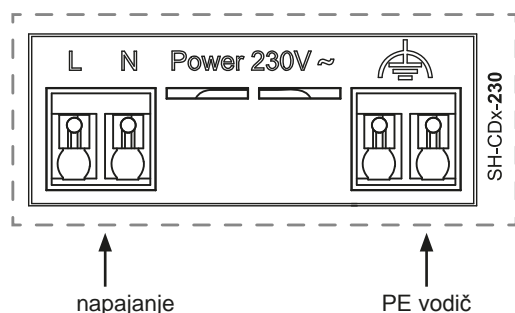

Zahtijeva korištenje TECE isporučenog transformatora (4 žice): SH-ST

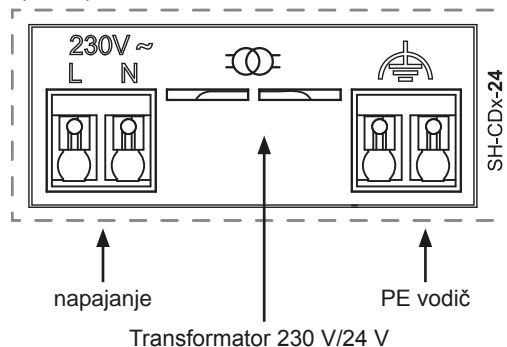

4.2 grijanje / hlađenje (H&C) ulaz

Svrha:

Ovaj ulaz omogućuje prebacivanje sustava: grijanje ili hlađenje.

Izvor signala:

- Ručni prekidač.
- Dizalica topline.
- SH-SM spojen na SH-CU središnju jedinicu kao ON/OFF uređaj. Ovo rješenje omogućuje daljinsko upravljanje načinom grijanja/hlađenja iz aplikacije ili s korisničkog računara.

Format signala: Ulaz može biti bez potencijala ili pod naponom od 230 V.

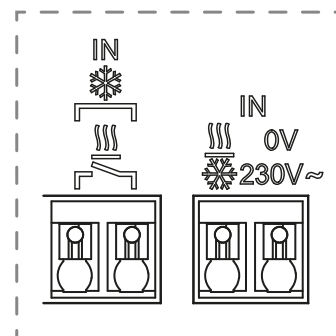

način rada	Besplatan kontakt	živi kontakt
Toplina	Otvoren	Nema signala
Cool	Zatvoreno	230 Vac

Samo jedan uređaj u sustavu trebao bi moći odabrati način H&C. Drugi mogući izvori signala za prebacivanje grijanja/hlađenja (vidi 0):

- Centralna jedinica (postavite ručni način H&C u izborniku centralne jedinice), DIP4/DIP5 = OFF/OFF.
- SH-CD HCM RF 230 s integriranim H&C ulazom, DIP4/DIP5 = ON/OFF.
- Digitalni termostat konfiguriran kao glavni H&C termostat u ručnom ili automatskom načinu rada (samo jedan termostat po instalaciji), DIP4/DIP5 = OFF/ON.

Ako postoji nekoliko SH-CD razdjelnika upravljanja u sustavu, H&C mod treba kontrolirati samo jednim uređajem:

- Bez središnje jedinice, sustav uzima u obzir kontrolni razdjelnik naveden kao glavni SH-CD (obratite pažnju na 5.1.2), DIP4/DIP5 = ON/ON.
- Sa centralnom jedinicom:
 - Kontrolni razdjelnik upravlja H&C načinom rada, DIP4/DIP5 = ON/ON.
 - Centralna jedinica upravlja načinom H&C, DIP4/DIP5 = OFF/OFF.

DIP4	DIP5	Prebacivanje signala H&C zahtjev kroz
OFF	OFF	Centralna jedinica (SH-CU)
OFF	ON	termostat
ON	OFF	Modul grijanje-hlađenje (SH-CD-HCM RF)
ON	ON	Kontrolni razdjelnik (SH-CD)

4.3 pumpa Izlaz

Postoje 2 izlaza:

- Izlaz kontakta pod naponom (230 Vac)
- Izlaz bez potencijala

Ovi izlazi mogu prebacivati sljedeće uređaje:

- Zonski ventil
- pumpa
- Bojler ili toplinska pumpa

2 izlaza se aktiviraju kada postoji zahtjev za grijanjem ili hlađenjem

- Na regulatoru kada je DIP sklopka 1 = OFF = lokalno
- U sustavu kada je DIP sklopka 1 = ON = globalno

Vidi 3.3.

Odgoda između zahtjeva za grijanjem ili hlađenjem i aktivacije crpke može se konfigurirati.

- Crpka se pokreće 2 minute nakon zahtjeva za grijanjem ili hlađenjem ako je DIP prekidač 3 = OFF
- Crpka se pokreće 5 minuta nakon zahtjeva za grijanjem ili hlađenjem ako je DIP prekidač 3 = ON

Vidi 3.3.

Ovo treba uzeti u obzir vrijeme otvaranja pokretača.

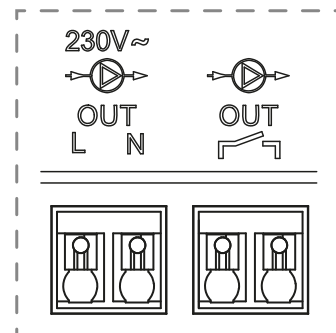

4.4 Kontakt za ograničenje temperature

Ovo je sigurnosni ulaz (slobodan kontakt).

kontakt zatvoren	kontakt otvoren
Bez sigurnosne detekcije	Detekcija previsoke temperature (grijanje) ili preniske temperature (hlađenje).

Sigurnosni ulaz treba koristiti kada je crpka spojena na regulator.

Kada je kontakt otvoren,

- izlaz lokalne pumpe je zaustavljen (čak i ako je DIP1 = ON, tj. globalna pumpa odabrana na regulatoru)
- pogoni su zatvoreni
- LED pumpe/sušilice treperi crveno
- LED za grijanje i hlađenje treperi crveno (u načinu grijanja) ili plavo (u načinu hlađenja).
- a regulator je pomoćni regulator, zahtjev za grijanje ili hlađenje ne šalje se glavnom regulatoru.

Možete koristiti kontaktni termostat za temperaturnu sigurnost.

Možete spojiti dva kontaktna termostata u seriju za zaštitu i od previsoke i od preniske temperature (sigurnosni ulaz tada je učinkovit i u načinu rada grijanja i hlađenja).

Proizvod dolazi s prenosnom žicom na konektoru .

Imajte na umu da pumpa SH-CD HCM RF 230 se pokreće kada se pumpa aktivira na najmanje jednom SH-CD instaliranom u sustavu.

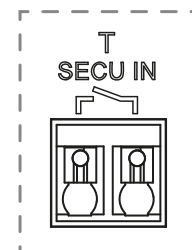

4.5 Ulaz za detekciju vlažnosti

Proizvod ima ulaz za detekciju vlage.

2 moguća tipa signala prema DIP8 (vidi 0)

- Kontaktni senzor vlažnosti (kontroler točke rosišta)
- Senzor temperature vode (CTN 10 kΩ): Zahtijeva SH-DTH termostat (radio humidistat)

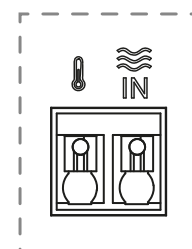

4.5.1 Kontaktni senzor vlage (kontrolor točke rosišta)

DIP8 = OFF

Format signala: Ulaz je slobodan kontakt

Nema vlage	otkrivena vlažnost
kontakt otvoren	kontakt zatvoren

U načinu hlađenja, kada se otkrije vlaga, regulator će:

- zaustaviti signal pumpe.
- zatvorite sve pogone zona.
- Pošaljite alarm vlažnosti drugom SH-CD u sustavu.
- Aktivirajte izlaz odvlaživača na SH-CD HCM RF 230.

Ako je regulator pomoćni regulator, zahtjev za hlađenjem neće biti poslan glavnom regulatoru.

4.5.2 NTC senzor za temperaturu vode

DIP8 = ON

Postoje 2 namjene za mjerenje temperature vode.

Detekcija vlažnosti

U načinu hlađenja, regulator izračunava točku rosišta za svaku zonu na temelju temperature okoline i relativne vlažnosti koju šalje svaki termostat (potreban je bežični higrostat).

Kada temperatura vode u zoni dosegne točku rosišta, aktivira se regulator:

sigurnosni pristup DIP7 = OFF	komforni pristup DIP7 = ON
Zatvara pokretač ove zone i zaustavlja zahtjev za hlađenjem u njoj.	Ostavlja pokretač te zone otvorenim jedan sat, zatim zatvara pokretač i zaustavlja zahtjev za hlađenjem u zoni ako se alarm vlažnosti nastavi aktivirati.

- Aktivira vanjski odvlaživač zraka u zoni.
- Zahtijeva od SH-CD HCM RF 230 da aktivira globalni odvlaživač zraka najmanje 15 minuta i dok alarm ne nestane ako u zoni nema dostupnog vanjskog odvlaživača.

Ako je regulator pomoćni regulator, zahtjev za hlađenjem neće biti poslan glavnom regulatoru.

Detekcija načina grijanja i hlađenja

Kada je DIP4/DIP5 = ON/ON (prebacivanje H&C = SH-CD) i DIP8 = ON, temperatura vode se koristi za automatsko otkrivanje načina H&C.

- Ako je temperatura vode > 24 °C, sustav je u načinu grijanja.
- ako je temperatura vode < 20 °C, sustav je u načinu hlađenja.

Ova je funkcija korisna kada se dizalica topline automatski prebacuje na način rada grijanja ili hlađenja i nema izlaz za obavještanje sustava.

- Kada SH-CD HCM RF 230 mjeri temperaturu vode, ova se vrijednost šalje SH-CD i koristi ako tamo nema senzora temperature vode.
- Ako je ulaz H&C = način hlađenja, sustav će se prebaciti u način rada hlađenja bez obzira na temperaturu vode.

4.6 NC/NO aktuatori

Spajanje jednog NC ili NO aktuatora po priključku

- Pogoni od 230 V za SH-CD-230
- 24 V pogoni za SH-CD-24

Tip aktuatora definiran je DIP2. Potrebno je koristiti isti tip za sve pogone.

Ako u zoni postoji zahtjev za grijanjem ili hlađenjem, aktuator će se odmah aktivirati.

Ako se zahtjev za grijanjem ili hlađenjem zaustavi,

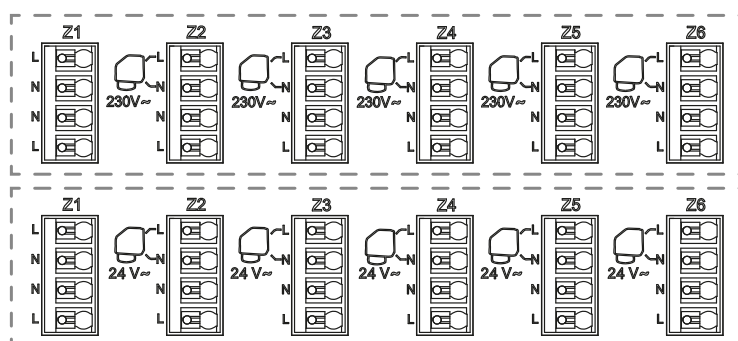

aktuator će se odmah onemogućiti osim ako to nije zadnji aktuator otvoren u regulatoru. U ovom slučaju kašnjenje prije zatvaranja aktuatora ovisi o DIP3 (vidi 0)

- ako je DIP3 = OFF, sustav čeka 5 minuta prije zatvaranja posljednje automatizacije
- ako je DIP3 = ON, sustav čeka 20 minuta prije zatvaranja posljednjeg pogona

Razlog: Mnoge dizalice topline imaju ugrađenu odgodu isključivanja (kako bi se izbjeglo uzastopno uključivanje i isključivanje ili ciklično mijenjanje). Toplinska pumpa nastavlja raditi x minuta nakon stvarnog vremena isključivanja. Važno je da barem jedan krug ostane otvoren osim ako u sustavu nema međuspremnik, razvodnika niskih gubitaka ili prenosnice.

4.7 Vanjska antena

U upravljač je ugrađena unutarnja antena. Ako je potrebno, može se spojiti vanjska antena za poboljšanje RF komunikacije. Ovo može biti korisno ako je upravljač instaliran u metalnom kućištu. U tom slučaju morate instalirati vanjsku antenu izvan metalnog kućišta.

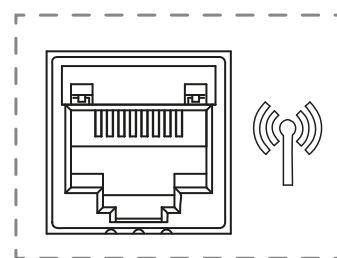

Pridržavajte se uputa za instalaciju kako biste optimizirali domet i izbjegli kvarove.

Antena mora biti instalirana na sljedeći način:

- izvan metalnog kućišta
- u okomitom položaju i najmanje 50 cm udaljen od metalnih dijelova

Ukoliko imate više antena (više kontrolera), one moraju biti postavljene na udaljenosti od najmanje 80 cm jedna od druge.

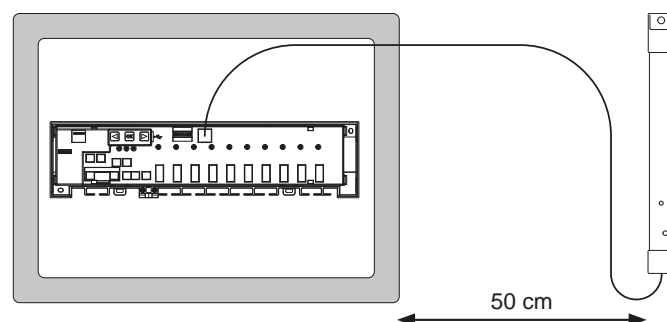





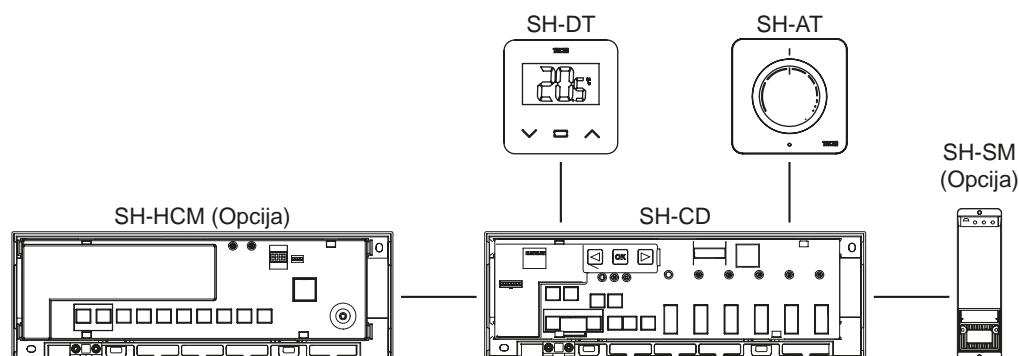

5. konfiguracija sustava

5.1 Konfiguracija sustava bez centralne jedinice

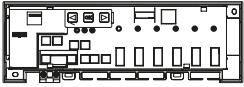
5.1.1 Samostalna instalacija

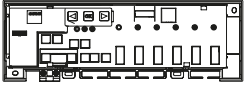
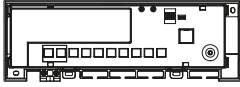
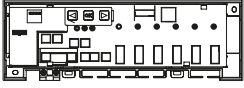
Samo jedan regulator ili više kontrolera bez međusobnog povezivanja

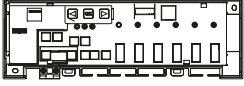

Gerät 1	Gerät 2	Bemerkungen
 <p>Pritiskom OK na 5 sekundi kontroler će se staviti u način RF uparivanja.</p> <p>Koristite ili za ◀ odabir ▶ zone 1 (LED treperi crveno) i pritisnite OK za ulazak u način rada za uparivanje termostata.</p> <p>Napomena: trepćući zeleni LED indikator je položaja.</p> <p>Koristite ▶ ili za pomicanje zelenog trepćućeg LED- ▶ a kako biste odabrali zonu(e) za uparivanje.</p> <p>Koristite za odabir OK ili poništavanje odabira zone.</p> <p>Odabrana zona je stalno crvena, ali i dalje treperi zeleno (indikator položaja).</p> <p>Već uparena zona je trajno zelena.</p>	 <p>termostati:</p> <p>Stavite uređaj u način RF uparivanja (pogledajte korisnički priručnik dotičnog uređaja).</p>	<p>Kada se bežično uparivanje završi, LED diode odabranih zona na SH-CD će se isključiti i termostati će izaći iz načina uparivanja.</p> <p>Za uparivanje drugog termostata morat ćete ponovno ući/ući u način rada.</p> <p>Izađite iz izbornika za uparivanje: dugo pritisnite ▶.</p>
 <p>Pritiskom OK na 5 sekundi kontroler će se staviti u način RF uparivanja.</p> <p>Koristite ili ▶ za odabir ▶ zone 3 (LED treperi crveno) i pritisnite OK za ulazak u mod uparivanja pomoćnih uređaja.</p> <p>Sve LED diode trepću zeleno.</p>	 <p>Stavite SH-CD HCM RF 230 u način RF spajanja. Da biste to učinili, pritisnite tipku 10 sekundi.</p> <p>Dodatne informacije možete pronaći u uputama za uređaj.</p>	<p>Kada se veza uspostavi, SH-CD vraća se u izbornik RF uparivanja, a SH-CD HCM RF 230 vraća se u normalni način rada.</p> <p>Izađite iz izbornika RF uparivanja: Dugo pritisnite ▶.</p> <p>NAPOMENA : samo jedan SH-CD HCM RF 230 modul grijanja i hlađenja po sustavu.</p>
 <p>Pritiskom OK na 5 sekundi kontroler će se staviti u način RF uparivanja.</p> <p>Koristite ili ▶ za odabir ▶ zone 3 (LED treperi crveno) i pritisnite OK za ulazak u mod uparivanja pomoćnih uređaja.</p> <p>Sve LED diode trepću zeleno.</p>	 <p>Versetzen Sie SH-SM in den RF-Kopplungsmodus.</p> <p>Drücken Sie dazu die Taste für 5 Sekunden.</p> <p>Weitere Hinweise entnehmen Sie der Anleitung des Gerätes.</p>	<p>Kada se veza uspostavi, SH-SM će izaći iz načina uparivanja.</p> <p>S druge strane, SH-CD vraća se u način rada za uparivanje.</p> <p>Izađite iz izbornika RF uparivanja: Dugo pritisnite ▶.</p>
 <p>Pritiskom OK na 5 sekundi kontroler će se staviti u način RF uparivanja.</p> <p>Koristite ili ▶ za odabir ▶ zone 3 (LED treperi crveno) i pritisnite OK za ulazak u mod uparivanja pomoćnih uređaja.</p> <p>Sve LED diode trepću zeleno.</p>	 <p>Stavite SH-R u način RF uparivanja. Da biste to učinili, pritisnite tipku 3 sekunde.</p> <p>Dodatne informacije možete pronaći u uputama za uređaj.</p>	<p>Kada se veza uspostavi, SH-R izlazi iz načina uparivanja. LED lampica stalno svijetli zeleno.</p> <p>S druge strane, SH-CD vraća se u način rada za uparivanje.</p> <p>Izađite iz izbornika RF uparivanja: Dugo pritisnite ▶.</p>

5.1.2 Ugradnja više kontrolera

Ako u sustavu postoji nekoliko međusobno povezanih kontrolera, postoji 1 glavni kontroler (Main SH-CD) i do 3 sekundarna kontrolera (Sub SH-CD).

Glavni kontroler centralizira informacije za podređene kontrolere. Ako se koristi modul za grijanje-hlađenje SH-CD HCM RF 230 , treba ga upariti s glavnim regulatorom.

- Glavni regulator prosjeđuje način grijanja i hlađenja podređenim regulatorima. Ove informacije mogu doći od SH-CD HCM RF 230 ili od glavnog digitalnog termostata ovisno o DIP4 i DIP5 (pogledajte 0)
- Glavni regulator može obraditi signal pumpe cijelog sustava prema DIP1 (vidi 0)

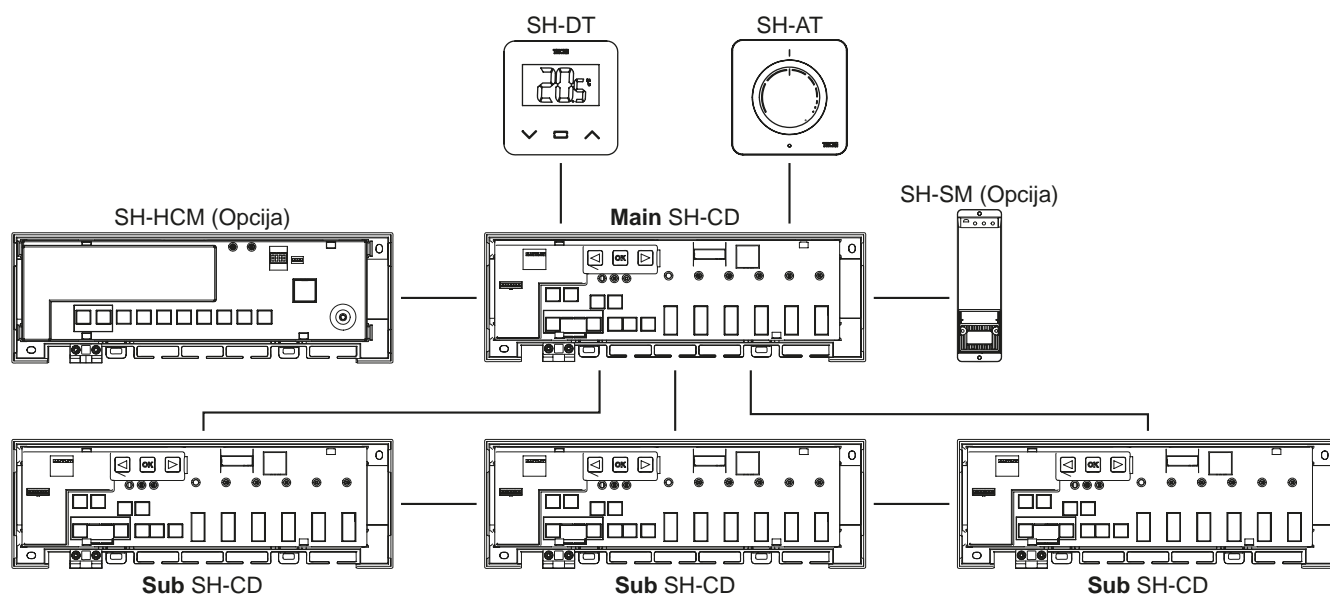



Uređaj 1: Glavni upravljač	Uređaj 2: Sekundarni regulator (pod)	Opaske
Zunächst sind alle Funk-Thermostate mit den jeweiligen Funk-Regelverteilern SH-CD zu paaren! Siehe 5.1.1		
<p>Pritiskom OK na 5 sekundi kontroler će se staviti u način RF uparivanja. Koristite ili za ◀ odabir ▶ zone 3 (LED treperi crveno) i pritisnite OK za ulazak u mod uparivanja pomoćnih uređaja. Sve LED diode trepću zeleno.</p>	<p>Pritiskom OK na 5 sekundi kontroler će se staviti u način RF uparivanja. Koristite ili za ◀ odabir ▶ zone 2 (LED treperi crveno) i pritisnite OK za ulazak u način rada za uparivanje glavnog kontrolera. Sve LED diode trepću crveno.</p>	<p>Kada se veza uspostavi, oba SH-CD vraćaju se u način rada za uparivanje. Izađite iz izbornika RF uparivanja: Dugo pritisnite ◀.</p>

5.2 Konfiguracija sustava s centralnom jedinicom

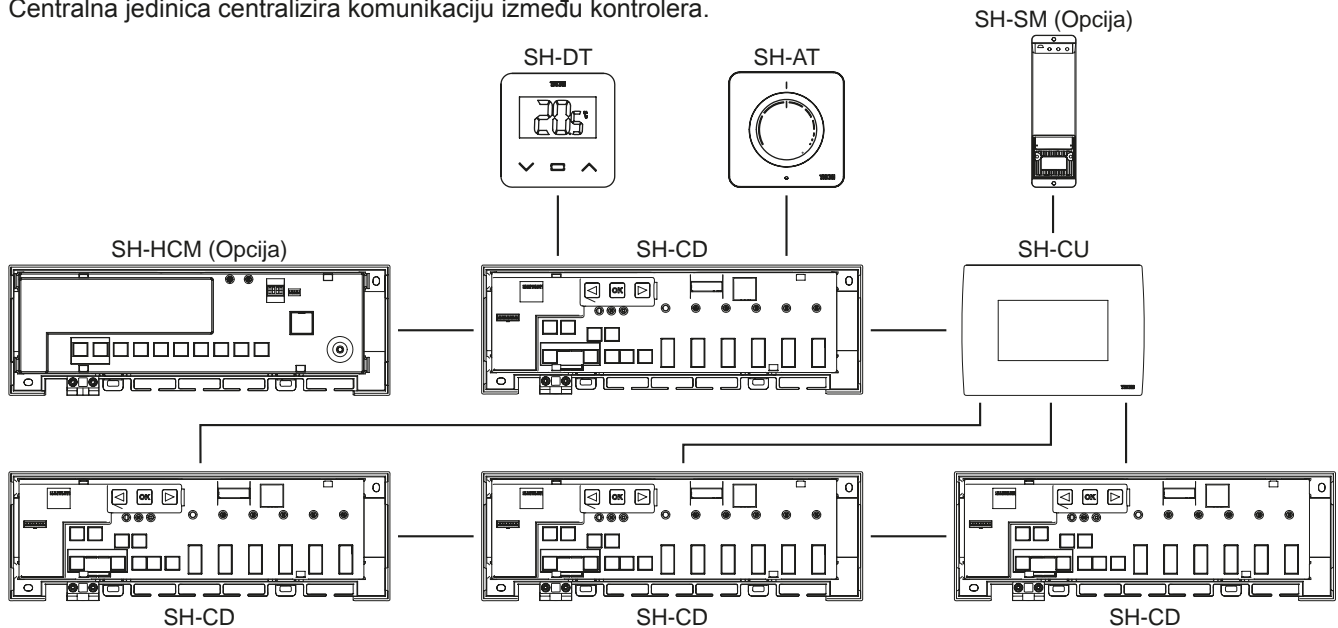
Centralna jedinica centralizira komunikaciju između kontrolera.

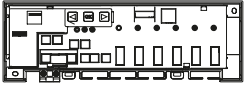

Uređaj 1: Glavni upravljač (glavni)	Uređaj 2: Sekundarni regulator (pod)	Opaske
Prvo, svi bežični termostati moraju biti upareni s odgovarajućim SH-CD bežičnim upravljačkim razdjelnicima! Vidi 5.1.1		
 <p>Pritiskom OK na 5 sekundi kontroler će se staviti u način RF uparivanja. Koristite ili za ◀ odabir ▶ zone 2 (LED treperi crveno) i pritisnite OK za ulazak u način rada za uparivanje glavnog kontrolera. Sve LED diode trepću crveno.</p>	 <p>Stavite uređaj u način RF uparivanja. Odaberite sobu (Soba 1). Prilikom uparivanja SH-CD s CT-02 RF, generira se soba za svaki bežični termostat. Sobe se stoga ne smiju unaprijed kreirati u centralnoj jedinici .</p>	<p>Kada se veza uspostavi, i SH-CD i SH-CU izaći će iz načina uparivanja. Izađite iz izbornika RF uparivanja: Dugo pritisnite ◀.</p>

5.3 Kontrola jednog odvlaživača po prostoriji.

Postoje 2 načina otkrivanja vlage:

- Na razini regulatora pomoću ulaza detekcije vlažnosti (vidi 4.5).
- Na razini prostorije ako termostat sadrži senzor za relativnu vlažnost zraka (radio higroskop).

Kada se otkrije vlaga, postoje 2 načina za aktiviranje odvlaživača:

- Globalni odvlaživač pokreće kada je funkcija omogućena na SH-HCM.
- Odvlaživač se aktivira na razini prostorije u kojoj je detektirana vlaga.

U ovom slučaju trebate upariti RF prijemnik BT-WR02 sa svakom zonom kontrolera kako biste aktivirali odvlaživač.

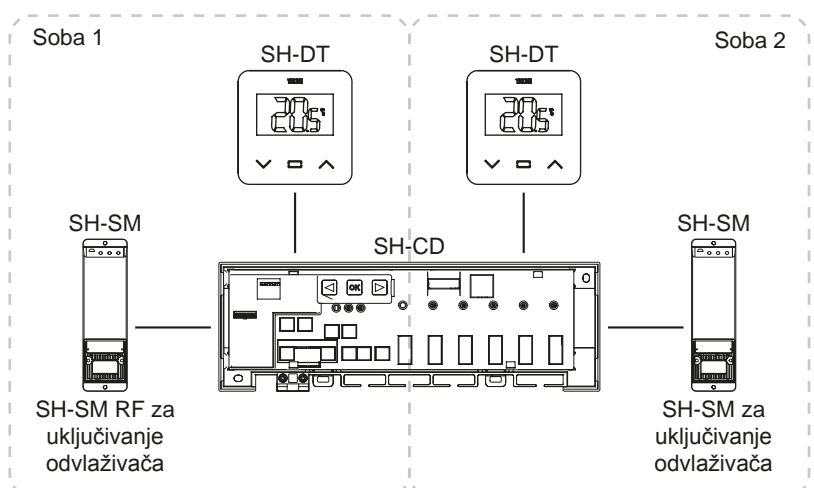

Uređaj 1: SH-CD	Uređaj 2: SH-SM	Opaske
<p>Pritiskom na 5 sekundi kontroler će se staviti u način RF uparivanja.</p> <p>Koristite ili za odabir Zone 4 (LED treperi crveno) i pritisnite za ulazak u način rada za uparivanje odvlaživača.</p> <p>Odaberite zone pomoću ili .</p> <p>Zone su definirane uparenim termostatima.</p> <p>Primjer: TH1 = Z1, TH2 = Z2+Z3 i TH3 = Z4+Z5+Z6. Navigacija predlaže 3 zone za uparivanje odvlaživača s (Z1), (Z2+Z3) i (Z4+Z5+Z6).</p> <p>Odaberite zonu pomoću isključeno/poništi odabir. (Možete odabrati samo jednu zonu po odvlaživaču).</p> <p>Kursor treperi zeleno.</p> <p>Odabrana zona treperi crveno i zeleno</p> <p>Već uparena zona je jednobojna zelena.</p> <p>(Da biste uklonili odvlaživač zraka, odaberite zonu sa zelenim LED-om, zatim pritisnite i istovremeno kako bi zona zatreperila zeleno).</p>	<p>Stavite SH-SM u način RF uparivanja.</p> <p>Da biste to učinili, pritisnite tipku 5 sekundi.</p> <p>Dodatne informacije možete pronaći u uputama za uređaj.</p>	<p>Kada se veza uspostavi, SH-SM će izaći iz načina uparivanja.</p> <p>S druge strane, SH-CD vraća se u način rada za uparivanje.</p> <p>Izađite iz izbornika RF uparivanja: Dugo pritisnite .</p>

6. Više značajki

6.1 Anti-Grip funkcija

Funkcija se aktivira preko DIP6 (vidi 0). Ako ventili nisu aktivni tijekom jednog tjedna, pokreće se kompletna vježba (aktuator + izlazi pumpe + zahtjev za grijanje/hlađenje, koji se šalje na SH-CD HCM RF 230 .

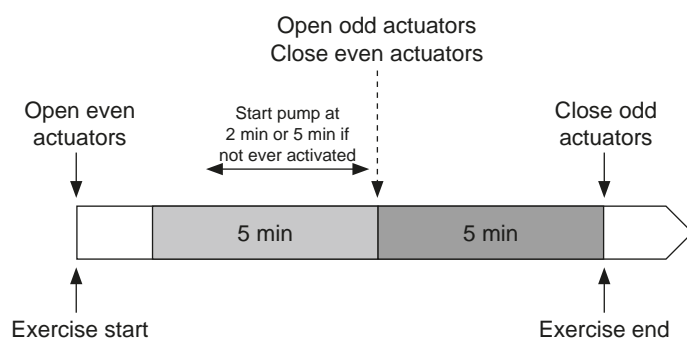

6.2 Vрати na zadano

U slučaju kvara, možda će biti potrebno vratiti proizvod na tvorničke postavke.

Pritiskom na 5 sekundi, upravljač se prebacuje na izbornik za resetiranje. LED žaruljica Zone1 će treperiti crveno, a LED diode preostalih zona će treperiti zeleno.

pritisnom na tipke , i dok sve LED diode zona ne zasvijetle crveno, aktivira se reset kontrolera i proizvod se ponovno pokreće. LED lampice se gasе.

6.3 rješavanje problema

simptom	problem	Opis	Rješavanje problema
LED diode za grijanje i hlađenje trepću crveno ili plavo i LED pumpa/sušilo treperi crveno.	sigurnosna detekcija.	Sigurnosni ulazni kontakt je aktiviran.	Ako ne koristite sigurnosni termostat, provjerite jeste li postavili kratkospojnik na sigurnosni ulaz temperature. U suprotnom, kontrolirajte temperaturu cijevi (prevruće u načinu grijanja, prehladno u načinu hlađenja).
Crveno/plavo trepćuće LED grijanje i hlađenje.	RF problem.	Regulator je izgubio komunikaciju s RF uređajem koji nije termostat.	Provjerite udaljenost između uređaja. Ako je kontroler instaliran u metalnom kućištu, koristite vanjsku antenu koja je izvan metalnog kućišta. Možda će biti potreban RF repetitor.
LED pumpe/odvlaživača brzo treperi plavo.	Problem konfiguracije vlažnosti.	NTC mjerenje na H&C ulazu s DIP8 = OFF. ON/OFF ulaz na H&C ulazu dok je DIP8 = ON.	Provjerite NTC senzor temperature i postavku DIP prekidača.
Trepće crveno na 1 zoni.	RF pogreška s termostatom.	Regulator je izgubio komunikaciju sa sobnim senzorom.	Provjerite razmak između regulatora i termostata.
Trepće crveno na svim zonama.	Greška RF antene.	Regulator je izgubio sve RF veze (termostat i drugi uređaji).	Možda će biti potreban RF repetitor.

7. TEHNIČKE KARAKTERISTIKE

7.1 Tehnički podaci

	SH-CD6-24, SH-CD6-230, SH-CD10-24, SH-CD10-230
električna zaštita	Klasa II sa zaštitnim vodičem
IP zaštita	IP30
temperatura transporta i skladištenja	-10 °C do 50 °C (14 °F do 122 °F)
napajanje	230 VAC ± 10% 50 Hz
Maksimalno izlazno opterećenje (2 izlaza)	Releji: 5 A
aktuatori	230 V / 24 V NC/NO do 2 W
kompatibilnost	SH-AT, SH-DT, SH-DTP, SH-HCM, SH-CU, SH-SM

7.2 mjere i težinu

SH-CD6-24 und SH-CD6-230:

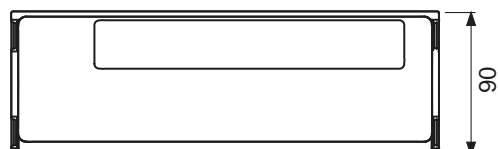
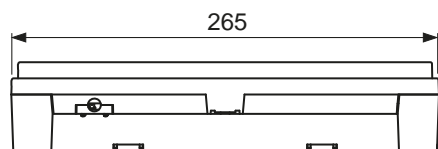

SH-CD10-24 und SH-CD10-v230:

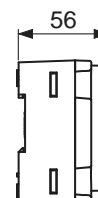
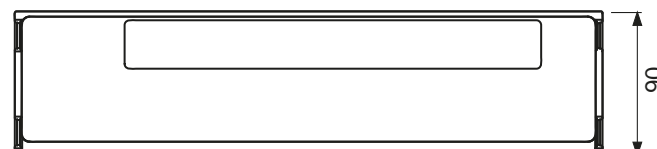
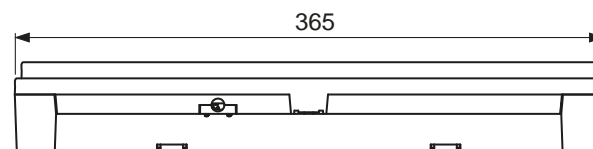

Gewicht: 840 g - SH-CD6
940 g - SH-CD10

8. POLITIKE

Oznaka	Opis	veza
Direktiva o niskom naponu (LVD)	Direktiva o niskom naponu (2014/35/EU) osigurava da električna oprema unutar određenih naponskih granica nudi visoku razinu zaštite za europske građane i u potpunosti iskorištava prednosti unutarnjeg tržišta.	2014/35/UE
Elektromagnetska kompatibilnost (EMC) Direktiva 2014/30/EU	Direktiva 2014/30/EU o elektromagnetskoj kompatibilnosti (EMC) osigurava da električni i elektronički uređaji ne stvaraju elektromagnetske smetnje niti da one na njih ne utječu.	2014/30/UE
Ograničenje uporabe određenih Direktiva o opasnim tvarima (RoHS) 2011/65/EU	Pravila koja ograničavaju korištenje određenih opasne tvari u električnoj i elektroničkoj opremi Oprema.	2011/65/EU
Električni otpad & Elektronička oprema Direktiva (WEEE)	Direktiva WEEE (2012/19/EU) ima za cilj smanjiti količinu WEEE koja ide na odlagalište.	2012/19/EU
Komisija za ekološki dizajn regulacija	Zahtjevi za ekološki dizajn za lokalne grijače prostora.	2015/1188
Direktiva o radijskoj opremi (RED) 2014/53/EU	Direktiva o radijskoj opremi 2014/53/EU (RED) definira pravni okvir za stavljanje radijske opreme na tržište.	2014/53/EU

Conținuto

1. INFORMAȚII GENERALE	130
1.1 Avertismente de siguranță și instrucțiuni de utilizare	130
1.2 Aplicație	130
2. PREZENTARE	130
2.1 Funcții	130
2.2 Conținutul cutiei	131
2.3 Prima instalare	131
3. DESCRIEREA PRODUSULUI	131
3.1 Semnificațiile culorilor LED	131
3.2 Tastele	131
3.3 Configurația comutatorului DIP	132
3.4 Stick USB	132
4. INTRĂRI/IEȘIRI	133
4.1 Sursa de alimentare	133
4.2 Încălzire/răcire (H&C) Intrare	133
4.3 Pompa de ieșire	134
4.4 Contact pentru limitarea temperaturii	134
4.5 Intrare de detectare a umidității	134
4.6 Actuatore NC/NO	135
4.7 Antenă externă	136
5. CONFIGURAȚIA SISTEMULUI	136
5.1 Configurația sistemului fără unitate centrală	136
5.2 Configurația sistemului cu unitate centrală	139
5.3 Controlați un dehumidicator pentru fiecare cameră	139
6. ALTE CARACTERISTICI	140
6.1 Caracteristica Anti Grip	140
6.2 Resetare	140
6.3 Depanarea defecțiunilor	141
7. CARACTERISTICI TEHNICE	141
7.1 Date tehnice	141
7.2 Dimensiuni și greutate	142
8. DIRECTIVE	142

1. INFORMAȚII GENERALE

1.1 Avertismente de siguranță și instrucțiuni de utilizare

Acest produs trebuie instalat de preferință de către un profesionist calificat. Sub rezerva respectării termenilor de mai sus, producătorul își asumă răspunderea pentru echipament conform prevederilor legale.

Toate instrucțiunile din acest manual de instalare și utilizare trebuie respectate atunci când se lucrează cu regulatorul. Defecțiunile datorate instalării necorespunzătoare, utilizării necorespunzătoare sau întreținerii necorespunzătoare anulează răspunderea producătorului.



Orice încercare de reparare anulează responsabilitatea și obligația de garanție și de înlocuire din partea producătorului. 2012/19/UE (Directiva WEEE): Produsele marcate cu acest simbol nu pot fi eliminate ca deșeuri municipale nesortate în Uniunea Europeană. Pentru o reciclare corespunzătoare, returnați acest produs furnizorului local la achiziționarea unui echipament nou echivalent sau aruncați-l la punctele de colectare desemnate. Pentru mai multe informații, consultați: www.recyclethis.info.

1.2 Aplicație

Controlerul a fost proiectat pentru a fi utilizat în camere rezidențiale, spații de birouri și instalații industriale. Verificați dacă instalația este conformă cu reglementările în vigoare înainte de funcționare pentru a asigura utilizarea corespunzătoare a instalației.

2. PREZENTARE

Cutia de conectare SH-CD este special concepută pentru a vă controla sistemul de încălzire și răcire prin pardoseală. Aceasta permite conectarea ușoară și rapidă a termostazelor și a actuatorilor. Sunt disponibile 4 versiuni:

	Versiunea 230 V	Versiunea 24 V
6 zone	SH-CD6-230	SH-CD6-24 (Necesită un transformator extern 230 V / 24 V: SH-ST)
10 zone	SH-CD10-230	SH-CD10-24 (Necesită un transformator extern 230 V / 24 V: SH-ST)

2.1 Funcții

Acesta a integrat mai multe funcții:

- Montat pe perete sau montat pe șină DIN
- Conexiuni de cablu cu descărcare de efort
- Indicarea stării cu LED-uri și comutator DIP pentru setarea dispozitivului
- Gestionarea 6 sau 10 zone cu 2 actuatore pe zonă
- Îmbinarea ușoară a zonelor pe același termostat
- Configurarea mai multor sisteme
- Intrare H&C (230 V și semnal fără tensiune)
- Măsurarea temperaturii apei (sonda nu este furnizată) pentru detectarea umidității
- Leșirea pompei sau a boilerului (230 V și semnal fără tensiune)
- Managementul anti-prindere
- contact pentru limitarea temperaturii
- Antenă RF internă, antenă externă opțională
- Funcționează cu actuatore NC și NO
- Conectivitate USB pentru actualizarea software-ului și înregistrarea datelor

2.2 Conținutul cutiei

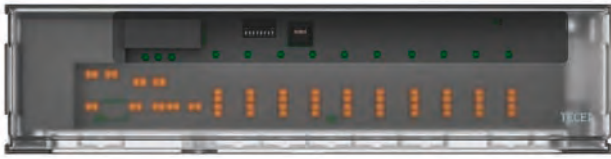

2.3 Prima instalare

Există 2 moduri de a instala controlerul:

- Se montează pe perete cu ajutorul a 2 șuruburi.
- Montat pe o șină DIN 35 x 7,5 (DIN EN 60715)

3. DESCRIEREA PRODUSULUI

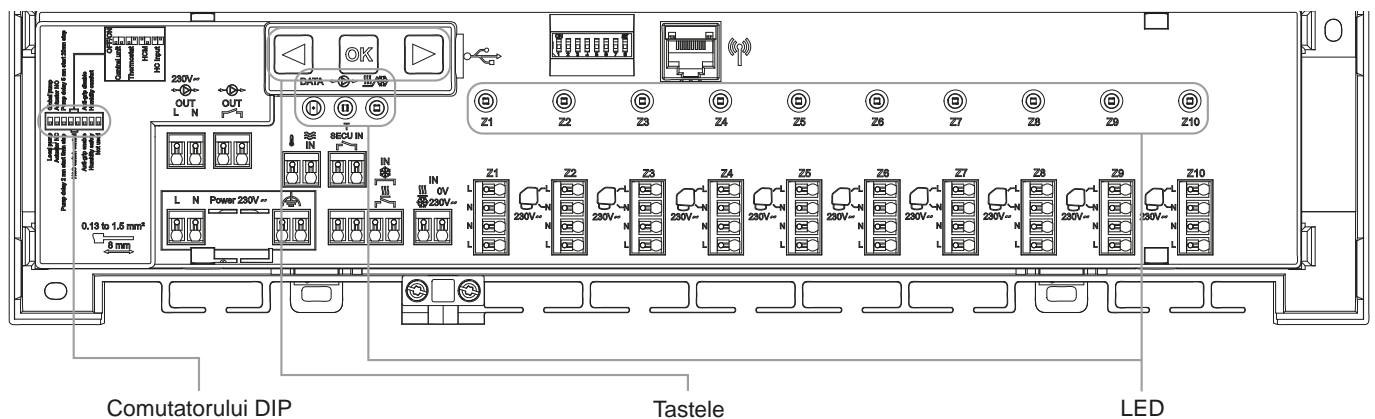

3.1 Semnificațiile culorilor LED

LED	Adică
LED de încălzire și răcire (roșu/albastru)	Fix Red = Modul de încălzire Fix Blue = Mod de răcire Roșu intermitent (în încălzire) sau albastru intermitent (în răcire) = Detecție de securitate Roșu / Albastru intermitent = Eroare RF (cu SH-CD, SH-HCM, SH-CU, antenă internă). În caz de eroare RF, sistemul trece în modul Încălzire.
LED pentru pompă/uscător (verde/albastru/roșu)	Fix Green = Pompa este declanșată Roșu intermitent = Eroare de sistem (detecție de securitate / eroare senzor de umiditate /...) Albastru intermitent = Detectarea umidității globale Albastru intermitent = Problemă de configurare a umidității
LED de date (roșu/verde)	Verde intermitent = Jurnal de date în curs Fix Red = Eroare USB Fix Green = USB conectat
LED pe zonă (roșu/verde)	Verde intermitent = Transmisie/recepție RF Fix Red = Cerere de încălzire sau răcire în zonă Roșu intermitent = Eroare RF la termostat Roșu intermitent pe toate zonele = Eroare de antenă RF. În cazul unei erori de radiofrecvență, sistemul trece în modul de încălzire.

3.2 Tastele

Sunt disponibile 3 taste capacitive:



3.3 Configurația comutatorului DIP

Numărul comutatorului DIP	Funcția	Valoare (implicit: OFF)		Configurație	Descriere
DIP1	Funcția de controler	OFF		Pompă locală	A se vedea 4.3
		ON		Pompă globală	
DIP2	Tipuri de acționare	OFF		Actuator NC	A se vedea 4.6
		ON		NO actuator	
DIP3	Întârzierea de pornire a pompei (pentru primul actuator în cerere) și întârzierea de oprire a actuatorului (pentru ultimul actuator în cerere)	OFF		2 min/5 min	A se vedea 4.3 și 4.6
		ON		5 min/20 min	
DIP4 / DIP5	Controlul comutatorului H&C	OFF	OFF	Unitatea centrală SH-CU	A se vedea 4.2
		OFF	ON	Termostat principal SH-DT	
		ON	OFF	SH-HCM	
		ON	ON	SH-CD	
DIP6	Anti Grip	OFF		Activat	A se vedea 6.1
		ON		Persoane cu handicap	
DIP7	Managementul umidității	OFF		Abordare de siguranță	A se vedea 4.5
		ON		Abordarea confortului	
DIP8	Senzor de umiditate	OFF		Senzor ON/OFF	A se vedea 4.5
		ON		Senzor de temperatură pentru țevi	

3.4 Stick USB



Conectivitatea USB permite :

- Pentru a actualiza software-ul controlerului.
- Pentru a înregistra date pentru monitorizarea sistemului (datalog).

Pentru actualizarea software-ului, vă rugăm să consultați wattswater.eu pentru a obține fișierul, puneți fișierul pe un stick USB.

- Introduceți stick-ul USB pe controler
- Porniți/opriți controlerul
- În timpul actualizării,
 - LED-ul verde este pornit de la Z1 la Z6/Z10.
 - Toate LED-urile devin roșii
 - LED-ul roșu este oprit de la Z6/Z10 la Z1
- După actualizare, puteți scoate stick-ul USB.

Pentru depistarea defecțiunilor, înregistrarea datelor este utilă pentru înregistrarea datelor într-un fișier ASCII stocat pe dispozitivul USB pentru depistarea defecțiunilor.

Apăsând  timp de 5 secunde, comandantul intră în meniul Funcții. LED-ul primei zone clipește fie în roșu (înregistrarea datelor este activată), fie în verde (înregistrarea datelor este dezactivată). Puteți activa sau dezactiva înregistrarea datelor făcând clic pe . Apăsarea prelungită pe  permite părăsirea meniului de funcții (în caz contrar, există un timp de așteptare de 10 secunde înainte de a părăsi automat meniul de funcții).

Se creează un fișier jurnal la fiecare 14 zile. În acest fișier, se face o înregistrare la fiecare 10 minute.

4. INTRĂRI/IEȘIRI

4.1 Sursa de alimentare

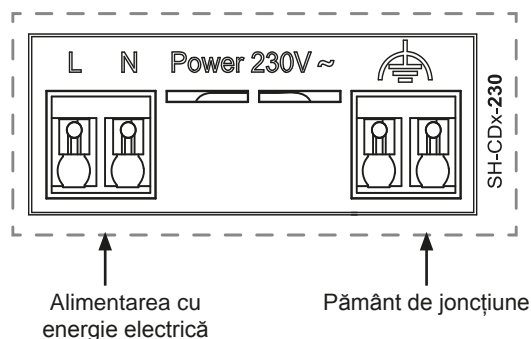

Necesită utilizarea unui transformator furnizat de TECE (4 cabluri): SH-ST

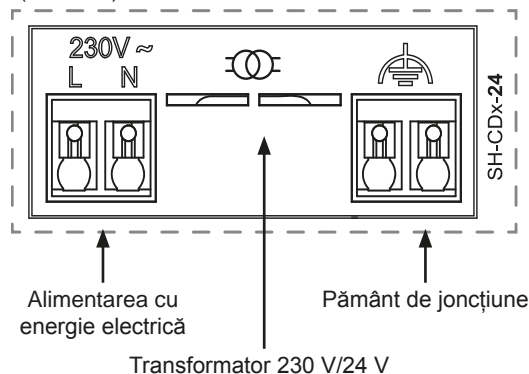

4.2 Încălzire/răcire (H&C) Intrare

Scop:

Această intrare permite comutarea modului de reglare a sistemului: Încălzire sau răcire.

Sursa semnalului:

- Un comutator mecanic
- O pompă de căldură
- Un SH-SM cuplat la unitatea centrală SH-CU ca dispozitiv ON/OFF. Această soluție permite obținerea unui control de la distanță al modului H&C din aplicații.

FormFormatul semnalului:

Intrarea poate fi un contact liber sau un contact sub tensiune de 230 V.

Mod	Contact liber	Contact live
Încălzire	Deschis	Nici un semnal
Răcire	Închis	230 V AC

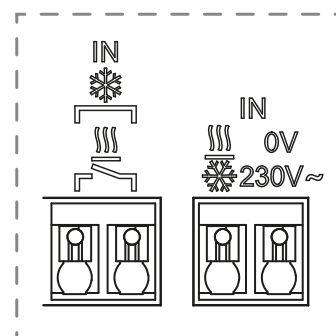

Numai un singur dispozitiv din sistem ar trebui să poată selecta modul H&C. Alte surse posibile de semnal de comutare H&C (a se vedea 3.3):

- Unitatea centrală (setați modul H&C manual în meniul de instalare al centralei) DIP4/DIP5 = OFF/OFF.
- SH-HCM care încorporează o intrare H&C DIP4/DIP5 = ON/OFF.
- Termostat digital configurat ca termostat Master H&C în mod manual sau automat (doar un singur termostat pe instalație) DIP4/DIP5 = OFF/ON.

Dacă aveți mai multe cutii de conectare SH-CD în sistem, modul H&C trebuie controlat de un singur controler:

- Fără centrală, sistemul consideră cutia de conectare setată ca principală SH-CD (consultați 5.1.2) DIP4/DIP5 = ON/ON.
- Cu centrală:
 - Dacă Cutia de conectare controlează modul H&C, DIP4/DIP5 = ON/ON.
 - Dacă unitatea centrală controlează modul H&C, DIP4/DIP5 = OFF/OFF.

DIP4	DIP5	Semnalul de comutare H&C solicitat de
OFF	OFF	Unitate centrală (SH-CU)
OFF	ON	Termostat
ON	OFF	Modul de încălzire și răcire (SH-HCM)
ON	ON	Cutie de conectare (SH-CD)

Pentru detalii, consultați capitolul 5.1.2

4.3 Pompa de ieşire

Există 2 ieşiri:

- Ieşire cu contact sub tensiune (230 V AC)
- Ieşire cu contact liber

Aceste ieşiri pot fi utilizate pentru a declanşa:

- O supapă de zonă
- O pompă
- Un cazan sau o pompă de căldură

Cele 2 ieşiri sunt declanşate atunci când există o cerere de încălzire sau de răcire (A se vedea 3.3).

- În controler, dacă comutatorul DIP 1 = OFF = local
- În sistem, dacă comutatorul DIP 1 = ON = global

Întârzierea dintre cererea de încălzire sau răcire și activarea pompei este configurabilă (A se vedea 3.3).

- Pompa porneşte la 2 minute după cererea de încălzire sau răcire dacă comutatorul DIP 3 = OFF
- Pompa porneşte la 5 minute după cererea de încălzire sau răcire dacă comutatorul DIP 3 = ON

Scopul este de a lua în considerare latenţa dispozitivului de acţionare.

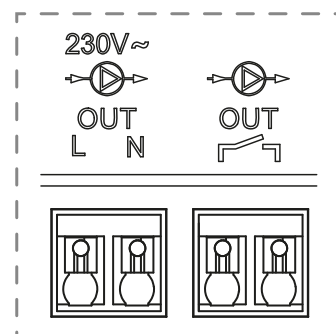

4.4 Contact pentru limitarea temperaturii

Aceasta este o intrare de securitate (contact liber).

Contact închis	Contact deschis
Nici o detecție de securitate	Detectarea supraîncălzirii sau a suprarăcirii.

Intrarea de securitate ar trebui să fie utilizată pe un controler cu o pompă.

Când contactul este deschis,

- Ieşirea pompei locale este oprită (chiar dacă DIP1=ON, adică pompa globală de pe regulator).
- Acţionările sunt închise
- Ledul pompă/uscător este roşu intermitent
- Ledul de încălzire și răcire clipește în roșu (în încălzire) sau în albastru (în răcire).
- Dacă regulatorul este un regulator secundar, cererea de încălzire sau de răcire nu este trimisă la regulatorul principal.

Puteți utiliza un termostat de contact pentru securitatea termică.

Puteți instala 2 termostate de contact în serie pentru a proteja atât împotriva supraîncălzirii, cât și a suprarăcirii (intrarea de securitate este valabilă atât în modul de încălzire, cât și în cel de răcire).

Produsul este livrat cu o curea pe conector.

Vă rugăm să rețineți că pompa SH-HCM este declanșată atunci când se declanșează cel puțin o pompă din mai multe SH-CD instalate în sistem.

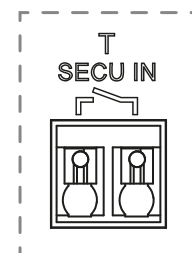

4.5 Intrare de detectare a umidității

Produsul are o intrare de detectare a umidității.

Două tipuri posibile de semnal în funcție de DIP8 (a se vedea 3.3)

- Senzor de temperatură a apei (CTN 10 kΩ): Necesită termostatul SH-DTH
- Un senzor de contact pentru umiditate

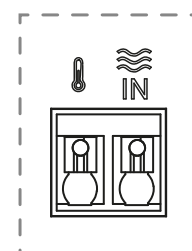

4.5.1 Senzor de contact pentru umiditate (control al punctului de rouă)

DIP8 = OFF

Formatul semnalului: Intrarea este un contact liber

Fără umezeală	Umiditate detectată
Contact deschis	Contact închis

În modul de răcire, atunci când este detectată umiditatea, controlerul

- Oprește semnalul pompei
- Închide toate actuatoarele
- Trimite alarmele de umiditate către toate celelalte SH-CD din sistem.
- Solicită SH-HCM să activeze dezumidificatorul.

În cazul în care controlerul este un controler secundar, cererea de răcire nu este trimisă la controlerul principal.

4.5.2 Senzor de temperatură a apei

DIP8 = ON

Măsurarea temperaturii apei are două utilizări.

Detectarea umidității

În modul de răcire, pentru fiecare zonă, controlerul calculează punctul de rouă pe baza temperaturii ambientale și a umidității relative trimise de fiecare termostat (este necesar un termostat cu senzor de umiditate relativă).

Atunci când temperatura apei atinge punctul de rouă într-o zonă, controlerul:

Abordare de siguranță DIP7 = OFF	Abordarea confortului DIP7 = ON
Închideți actuatorul zonei și opriți cererea de răcire a zonei.	Țineți deschis dispozitivul de acționare a zonei timp de o oră, apoi închideți dispozitivul de acționare și opriți cererea de răcire în zonă dacă alarma de umiditate este încă declanșată.

- Activați dezumidificatorul de la distanță al zonei
- Solicită SH-HCM să activeze dezumidificatorul global timp de cel puțin 15 minute și să aștepte dispariția alarmei dacă în zonă nu este disponibil niciun dezumidificator la distanță.

Dacă controlerul este un controler secundar, cererea de răcire a zonei nu este trimisă la controlerul principal.

Detectarea modului de încălzire și răcire

Când DIP4 = ON și DIP5 = ON (control comutator H&C = SH-CD) și DIP8 = ON temperatura apei este utilizată pentru a detecta automat modul H&C.

- Dacă temperatura apei > 24 °C, sistemul este în modul de încălzire
- Dacă temperatura apei este < 20 °C, sistemul este în modul de răcire.

Această funcție este utilă atunci când pompa de căldură comută automat în modul de încălzire sau răcire și nu are o ieșire care să informeze sistemul.

- Dacă SH-HCM măsoară o temperatură a apei, temperatura este trimisă la SH-CD, care poate fi utilizat dacă nu există un senzor de temperatură a apei.
- Dacă intrarea H&C= mod răcire, sistemul comută în modul răcire indiferent de temperatura apei.

4.6 Actuatoare NC/NO

Conectați un actuator NC sau NO pe conector

- Acționări 230 V pentru SH-CDx-230
- Acționări 24 V pentru SH-CDx-24

Tipul de acționare este definit de DIP2. Este necesar să se utilizeze același tip pentru toate actuatoarele.

Atunci când cererea de încălzire sau de răcire este oprită, servomotorul este închis imediat, cu excepția cazului în care acesta este ultimul servomotor deschis în regulator.

În acest caz, întârzierea înainte de a începe să se închidă actuatorul depinde de DIP3 (a se vedea 3.3)

- dacă DIP3=OFF, sistemul așteaptă 5mn înainte de a închide ultimul actuator
- dacă DIP3=ON, sistemul așteaptă 20mn înainte de a închide ultimul actuator

Justificare: Multe pompe de căldură au o întârziere de oprire încorporată (pentru a evita oprirea și pornirea succesivă a comutatorului). În acest caz, pompa de căldură continuă să funcționeze timp de x minute dincolo de timpul efectiv de oprire. Este important să păstrați cel puțin un circuit deschis, cu excepția cazului în care în instalație există un rezervor tampon, un comutator hidraulic sau un bypass.

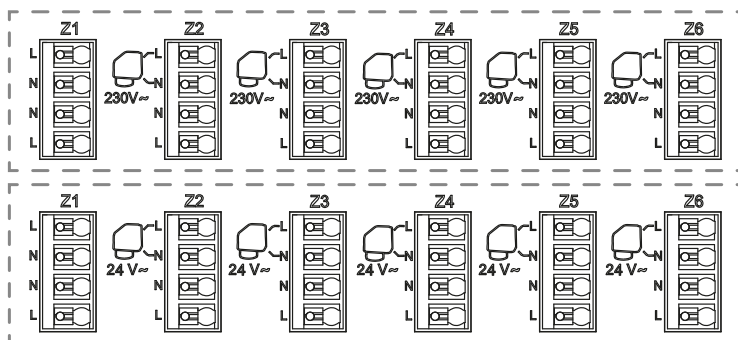

4.7 Antenă externă

Controlerul încorporează o antenă internă. Dacă este necesar, poate fi conectată o antenă externă pentru a îmbunătăți comunicarea RF. Aceasta ar putea fi utilă în cazul în care controlerul este instalat în interiorul unei cutii metalice. În acest caz, trebuie să instalați antena externă în afara cutiei metalice.

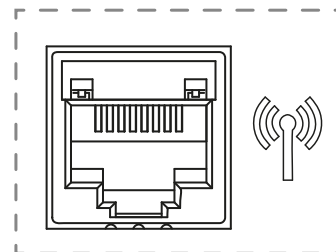

Vă rugăm să respectați montajul pentru a optimiza sensibilitatea și a evita orice disfuncționalitate.

Antena trebuie instalată:

- în afara cutiei metalice
- în poziție verticală și la o distanță de cel puțin 50 cm de piesele metalice

Dacă aveți mai multe antene (mai multe controlere), acestea trebuie să fie amplasate la o distanță de cel puțin 80 cm una de cealaltă.

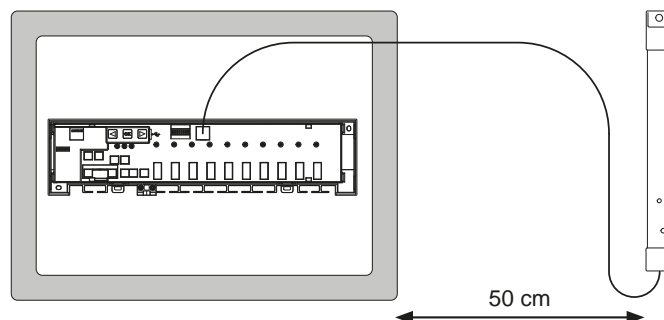





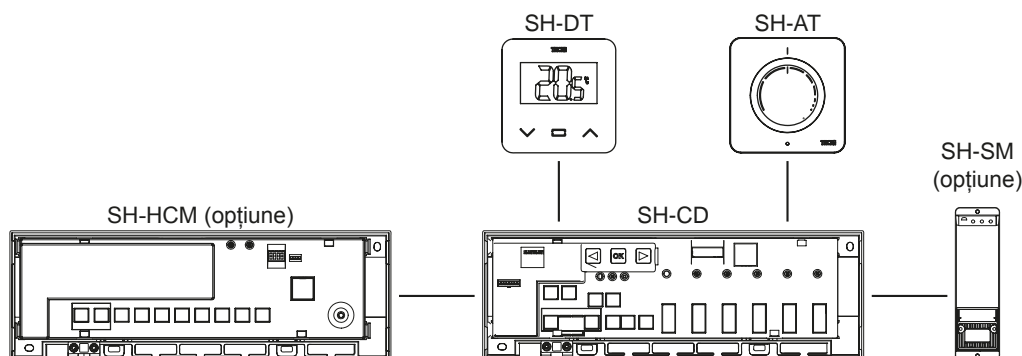

5. CONFIGURAȚIA SISTEMULUI

5.1 Configurația sistemului fără unitate centrală

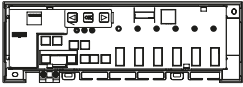
5.1.1 Instalare autonomă

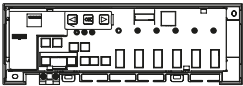
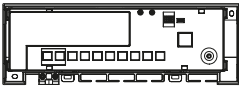
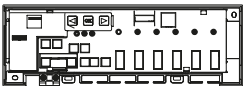
Un singur controler sau mai multe controlere fără interconectare

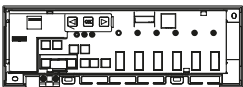

Dispozitiv 1	Dispozitivul 2	Observații
 <p>Prin apăsarea OK timp de 5 secunde, controlerul intră în modul de împerechere RF.</p> <p>Cu ajutorul ◀ sau ▶ selectați zona 1 (LED-ul clipește în roșu), apăsați OK pentru a intra în modul de împerechere cu termostatul. Un LED verde care clipește este un indicator de poziție.</p> <p>Deplasați LED-ul verde intermitent cu ◀ sau ▶ pentru a selecta zona (zonele) care urmează să fie împerecheate. Selectați/deselectați zona cu OK Zona selectată este fixată în roșu, dar continuă să clipească în verde (indicator de poziție).</p> <p>Zona deja împerecheată este fixată în verde.</p>	 <p>Termostate:</p> <p>Setați produsul în modul de împerechere RF (consultați manualul dispozitivului respectiv).</p>	<p>Dacă se realizează împerecherea RF, LED-urile zonelor selectate pe SH-CD trebuie să se stingă, iar termostatele trebuie să iasă din modul de împerechere.</p> <p>Pentru a împerechea un alt termostat, trebuie să introduceți/porniți din nou modul.</p> <p>leșirea din modul de cuplare a regulatorului: Apăsați lung pe ◀.</p>
 <p>Prin apăsarea OK timp de 5 secunde, controlerul intră în modul de împerechere RF.</p> <p>Cu ajutorul ◀ sau ▶ selectați zona 3 (LED-ul clipește în roșu), apăsați OK pentru a intra în modul de împerechere cu un dispozitiv sclav.</p> <p>Toate LED-urile clipească în verde.</p>	 <p>Setați dispozitivul în modul de cuplare RF. Apăsați butonul timp de 10 secunde.</p> <p>Pentru informații suplimentare, consultați manualul dispozitivului respectiv.</p>	<p>Când legătura este realizată, SH-CD și SH-HCM revin la modul de cuplare.</p> <p>leșirea din modul de cuplare a regulatorului: Apăsați lung pe ◀.</p> <p>OBSERVAȚIE: un singur modul de răcire cu căldură SH-HCM pe instalație.</p>
 <p>Prin apăsarea OK timp de 5 secunde, controlerul intră în modul de împerechere RF.</p> <p>Cu ajutorul ◀ sau ▶ selectați zona 3 (LED-ul clipește în roșu), apăsați OK pentru a intra în modul de împerechere cu un dispozitiv sclav.</p> <p>Toate LED-urile clipească în verde.</p>	 <p>Setați SH-SM în modul de cuplare RF.</p> <p>Apăsați butonul timp de 5 secunde.</p> <p>Pentru informații suplimentare, consultați manualul dispozitivului.</p>	<p>Când legătura este realizată, SH-SM RF iese din modul de cuplare.</p> <p>SH-CD revine la modul de cuplare.</p> <p>leșirea din modul de cuplare a regulatorului: Apăsați lung pe ◀.</p>
 <p>Prin apăsarea OK timp de 5 secunde, controlerul intră în modul de împerechere RF.</p> <p>Cu ajutorul ◀ sau ▶ selectați zona 3 (LED-ul clipește în roșu), apăsați OK pentru a intra în modul de împerechere cu un dispozitiv sclav.</p> <p>Toate LED-urile clipească în verde.</p>	 <p>Setați SH-R în modul de cuplare RF.</p> <p>Apăsați butonul timp de 3 secunde.</p> <p>Pentru informații suplimentare, consultați manualul dispozitivului.</p>	<p>Când legătura este realizată, SH-R iese din modul de cuplare.</p> <p>SH-CD revine la modul de cuplare.</p> <p>leșirea din modul de cuplare a regulatorului: Apăsați lung pe ◀.</p>

5.1.2 Instalarea mai multor controlere

Dacă în instalație există mai multe controlere interconectate, există un controler principal (Main SH-CD) și până la 3 subcontrolere (Sub SH-CD).

Controlerul principal centralizează informațiile pentru subcontrolere. Dacă se utilizează un modul de răcire cu căldură SH-HCM, acesta trebuie să fie cuplat la controlerul principal.

- Controlerul principal propagă modul de încălzire și răcire la subcontrolere. Aceste informații pot proveni de la SH-HCM sau de la un termostat Master Digital în funcție de DIP4 și DIP5 (a se vedea 3.3)
- Controlerul principal ar putea gestiona semnalul de pompare al întregii instalații în funcție de DIP1 (Vezi 3.3)

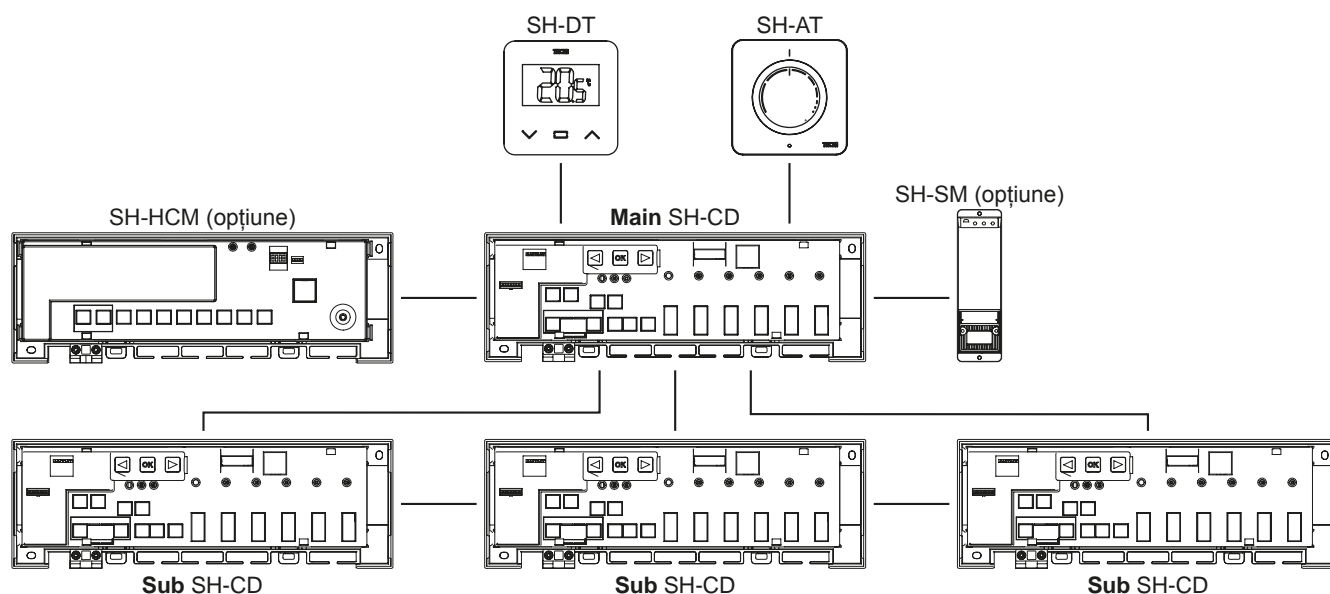

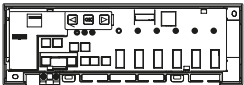
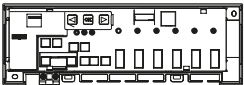
Gerăt 1: Controler principal	Gerăt 2: Controler secundar	Observații
În primul rând, toate termostatele radio trebuie să fie împerecheate cu controlerul SH-CD respectiv! A se vedea 5.1.1.		
 <p>Prin apăsarea OK timp de 5 secunde, controlerul intră în modul de împerechere RF.</p> <p>Cu ajutorul ◀ sau ▶ selectați zona 3 (LED-ul clipește în roșu), apăsați OK pentru a intra în modul de împerechere cu un dispozitiv sclav. Toate LED-urile clipeșc în verde.</p>	 <p>Prin apăsarea OK timp de 5 secunde, controlerul intră în modul de împerechere RF.</p> <p>Cu ajutorul ◀ sau ▶ selectați zona 3 (LED-ul clipește în roșu), apăsați OK pentru a intra în modul de împerechere cu un dispozitiv principal. Toate LED-urile clipeșc în roșu.</p>	<p>Când se încheie împerecherea RF, atât SH-CD cât și SH-CD revin la modul de împerechere.</p> <p>leșirea din meniul de asociere a controlerului: Apăsați lung pe auf ◀.</p>

5.2 Configurația sistemului cu unitate centrală

Unitatea centrală centralizează comunicarea între controlere.

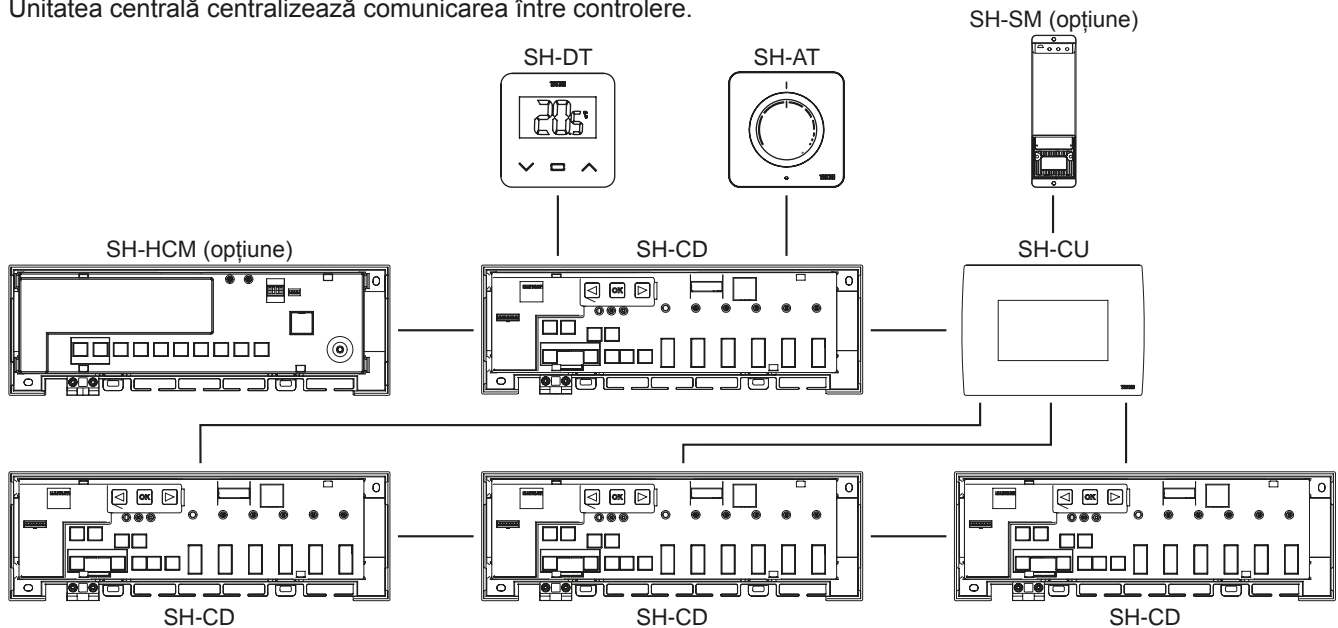

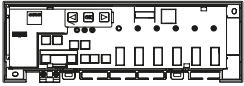
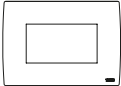
Dispozitivul 1: SH-CD	Dispozitivul 2: SH-CU	Observații
În primul rând, toate termostatele radio trebuie să fie împerecheate cu controlerul SH-CD respectiv! A se vedea 5.1.1.		
 <p>Prin apăsarea OK timp de 5 secunde, controlerul intră în modul de împerechere RF.</p> <p>Cu ajutorul ◀ sau ▶ selectați zona 3 (LED-ul clipește în roșu), apăsați OK pentru a intra în modul de împerechere cu un dispozitiv principal.</p> <p>Toate LED-urile clipește în roșu.</p>	 <p>Treceți dispozitivul în modul de împerechere RF. Selectați o cameră (Camera 1).</p> <p>Când se împerechează un SH-CD cu SH-CU, se generează o cameră pentru fiecare termostat fără fir. Prin urmare, camerele nu trebuie create în prealabil în unitatea centrală.</p>	<p>Când se realizează împerecherea RF, atât SH-CD, cât și SH-CU ies din modul de împerechere.</p> <p>leșirea din meniul de asociere a controlerului: Apăsați lung pe ◀.</p>

5.3 Controlați un dezumidificator pentru fiecare cameră









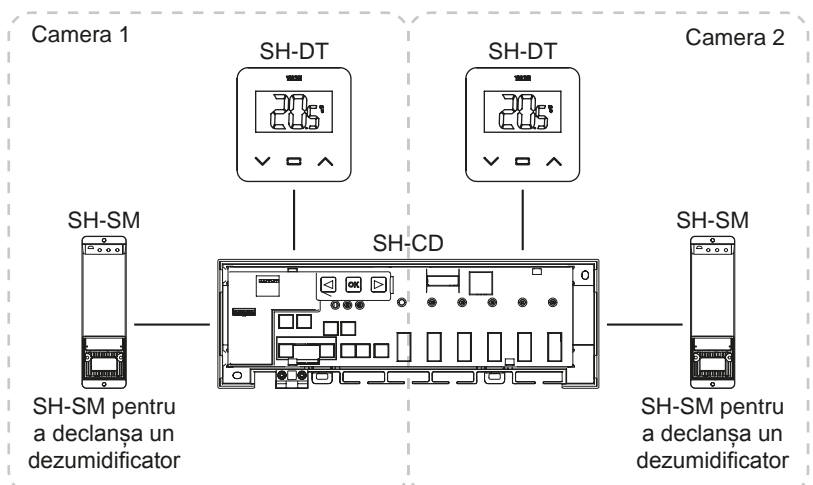

Există 2 moduri de a detecta umiditatea:

- La nivelul controlerului, utilizând intrarea de detectare a umidității (a se vedea 4.5).
- La nivelul camerei, dacă termostatul integrează un senzor de umiditate relativ).

Atunci când este detectată umiditatea, există 2 moduri de a declanșa dezumidificatorul:

- Un dezumidificator global este declanșat de către SH-HCM dacă funcția este activată pe SH-HCM.
- Un dezumidificator este declanșat la nivelul camerei în care este detectată umiditatea. În acest ultim caz, trebuie să asociați un receptor SH-SM pe fiecare zonă a controlerului pentru a declanșa un dezumidificator.



Dispozitivul 1: SH-CD	Dispozitivul 2: SH-SM	Observații
<p>Prin apăsarea  timp de 5 secunde, controlerul intră în meniul de împerechere RF.</p> <p>Cu ajutorul  sau  selectați zona 4 (LED-ul clipește în roșu), apăsați  pentru a intra în modul de împerechere a dezumidicatorului.</p> <p>Alegeți zonele cu  sau . Zonele sunt definite de canale de termostat împerecheate. De exemplu: TH1 = Z1, TH2 = Z2+Z3 și TH3 = Z4+Z5+Z6.</p> <p>Navigarea propune 3 zone pentru a împerechea un dezumidicator pe (Z1), (Z2+Z3) și (Z4+Z5+Z6).</p> <p>Selectați/deselectați zona cu . (Puteți selecta doar o singură zonă pentru fiecare dezumidicator).</p> <p>Cursorul clipește în verde.</p> <p>Zona selectată clipește în roșu și verde.</p> <p>Zona deja împerecheată este fixată în verde.</p> <p>(Pentru a scoate un dezumidicator, selectați o zonă în verde, apoi apăsați simultan pe  și , pentru ca zona să clipească în verde).</p>	 <p>Setați SH-SM în modul de cuplare RF.</p> <p>Apăsați butonul timp de 5 secunde.</p> <p>Pentru informații suplimentare, consultați manualul dispozitivului.</p>	<p>WCând legătura este realizată, SH-SM iese din modul de cuplare.</p> <p>SH-CD revine la modul de cuplare.</p> <p>Ieșirea din modul de cuplare a regulatorului: Apăsați lung pe .</p>

6. ALTE CARACTERISTICI

6.1 Caracteristica Anti Grip

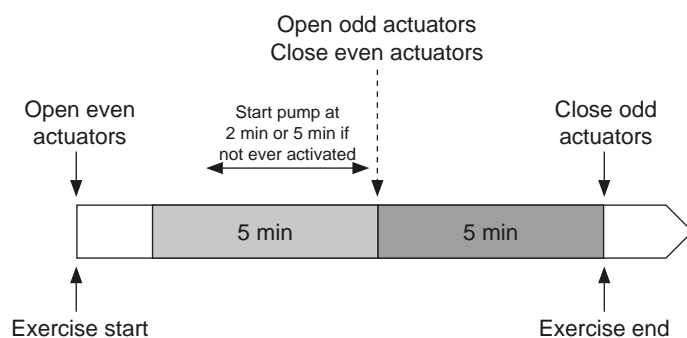

Funcția este activată cu ajutorul DIP6 (a se vedea 3.3). Dacă supapele nu sunt active pe parcursul unei săptămâni, se declanșează un exercițiu complet (actuador + ieșiri ale pompei + cerere de căldură/răcire trimisă la SH-HCM).



6.2 Resetare

În cazul unei disfuncționalități, este posibil să fie necesară resetarea produsului la setările din fabrică.

Prin apăsarea  timp de 5 secunde, comandantul intră în meniul Reset. LED-ul din zona 1 începe să clipească în roșu, iar LED-ul celorlalte zone începe să clipească în verde.

Apoi, prin apăsarea simultană pe ,  și  până la obținerea tuturor LED-urilor de zonă în roșu, se declanșează resetarea controlerului și produsul repornește. LED-urile se opresc.

6.3 Depanarea defecțiunilor

Simptome	Probleme	Descriere	Depanarea defecțiunilor
Roșu sau albastru intermitent pe LED-ul de încălzire și răcire și Roșu intermitent pe LED-ul pompă/ uscător.	Detectarea securității	Contactul intrării de securitate este deschis	Dacă nu folosiți un termostat de securitate, asigurați-vă că ați instalat o curea pe intrarea termostatului de securitate. În caz contrar, controlați temperatura conductei (prea cald în modul de încălzire, prea rece în modul de răcire)
Roșu/Albastru clipește pe LED-ul de încălzire și răcire	Problema RF	Controlerul a pierdut conexiunea cu un dispozitiv RF, altul decât un termostat	Verificați distanța dintre dispozitive. În cazul în care controlerul este instalat într-o cutie metalică, utilizați o antenă externă situată în afara cutiei metalice. Este posibil să fie necesar un repetor RF.
Clipire rapidă albastră pe LED-ul pompei/ uscător	Problema de configurare a umidității	Măsurarea CTN pe intrarea H&C în timp ce DIP8 = OFF. Intrare ON/OFF la intrarea H&C, în timp ce DIP8 = ON	Verificați CTN și setarea comutatorului DIP
Roșu intermitent pe 1 zonă	Eroare RF cu termostatul	Controlerul a pierdut legătura cu termostatul.	Verificați distanța dintre regulator și termostat. Este posibil să fie necesar un repetor RF.
Roșu intermitent pe toate zonele	Eroare de antenă RF	Controlerul a pierdut toate conexiunile RF (termostat și alte dispozitive)	Este posibil să fie necesară o antenă externă.

7. CARACTERISTICI TEHNICE

7.1 Date tehnice

	SH-CD6-24, SH-CD6-230, SH-CD10-24, SH-CD10-230
Protecție electrică	Clasa II cu pământ funcțional
Protecție IP	IP30
Temperatura de transport și depozitare	-10 °C la 50 °C (14 °F la 122 °F)
Alimentarea cu energie electrică	230 V AC ± 10 % 50 Hz
Sarcina maximă de ieșire (2 ieșiri)	Releu: 5 A
Actuatoare	230 V/24 V NC/NO până la 2 W
Compatibilitate	SH-AT, SH-DT, SH-DTP, SH-HCM, SH-CU, SH-SM

7.2 Dimensiuni și greutate

SH-CD6-24 și SH-CD6-230:

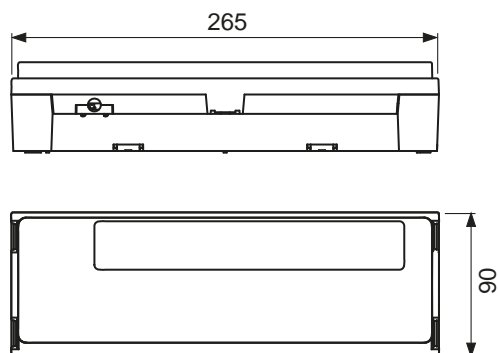

SH-CD10-24 și SH-CD10-v230:

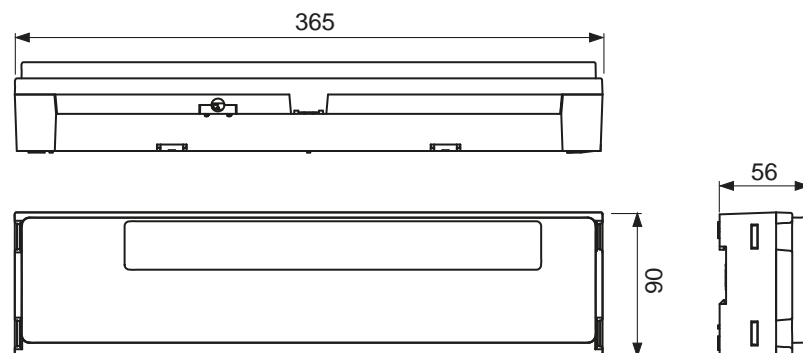

Greutate: 840 g - SH-CD6
940 g - SH-CD10

8. DIRECTIVE

Desemnare	Descriere	Link
Directiva privind joasă tensiune (LVD)	Directiva privind joasă tensiune (LVD) (2014/35/UE) garantează că echipamentele electrice care se încadrează în anumite limite de tensiune asigură un nivel ridicat de protecție pentru cetățenii europeni și beneficiază pe deplin de piața unică.	2014/35/UE
Compatibilitate electromagnetică (EMC) Directiva 2014/30/UE	Directiva 2014/30/UE privind compatibilitatea electromagnetică (CEM) garantează că echipamentele electrice și electronice nu generează perturbații electromagnetice sau nu sunt afectate de acestea.	2014/30/UE
Restricția de utilizare a anumitor Directiva privind substanțele periculoase (RoHS) 2011/65/UE	Directiva privind restricțiile de utilizare a anumitor substanțele periculoase din instalațiile electrice și electronice echipamente.	2011/65/UE
Deșuri electrice & Echipamente electronice Directiva (WEEE)	Directiva DEEE (2012/19/UE) are ca scop reducerea cantității de deșuri de echipamente electrice și electronice care ajung la groapa de gunoi.	2012/19/UE
Comisia pentru proiectare ecologică Regulamentul	Cerințe de proiectare ecologică pentru încălzitoarele locale.	2015/1188
Directiva privind echipamentele radio (RED) 2014/53/UE	Directiva 2014/53/UE privind echipamentele radio (RED) stabilește un cadru de reglementare pentru introducerea pe piață a echipamentelor radio.	2014/53/UE

TECE GmbH
Germany
T + 49 25 72 / 9 28 - 0
info@tece.com
www.tece.com