

Heizen-Kühlen-Modul / Heating/cooling module SH-HCM 77420066



DE	BEDIENUNGSANLEITUNG	3
GB	USER GUIDE	11
FR	GUIDE D'UTILISATION	19
ES	GUIA DE USUARIO	27
IT	GUIDA UTENTE	35
NL	HANDLEIDING	43
NO	BRUKERHANDBOK	51
SE	BRUKSANVISNING	59
HR	PRIRUČNIK ZA RAD	67
RO	GHIDUL UTILIZATORULUI	75

Inhalt

1.	Allgemeine Informationen	4
1.1	Sicherheitshinweise und Betriebsanleitung	4
1.2	Anwendung	4
2.	Präsentation	4
2.1	Funktionen	4
2.2	Inhalt der Box	5
2.3	Erstmalige Installation	5
3.	Produktbezeichnung	5
3.1	LED-Farbbedeutungen	5
3.2	Drucktaste	6
3.3	DIP-Schalter-Konfiguration	6
4.	Eingänge/Ausgänge	6
4.1	Stromversorgung	6
4.2	Heizung/Kühlung Eingang	6
4.3	Pumpenleistung	7
4.4	Eingang Feuchteerkennung	7
4.5	Ausgang Luftentfeuchter	7
4.6	Heizen und Kühlen Ausgänge	8
4.7	Externe Antenne	8
5.	Systemkonfiguration	8
6.	Fehlersuche	9
7.	Technische Merkmale	9
7.1	Technische Daten	9
7.2	Abmessungen und Gewicht	10
8.	Richtlinien	10

1. Allgemeine Informationen

1.1 Sicherheitshinweise und Betriebsanleitung

Dieses Produkt sollte vorzugsweise von einem qualifizierten Fachmann installiert werden. Vorbehaltlich der Einhaltung der oben genannten Bedingungen übernimmt der Hersteller die Haftung für das Gerät im Rahmen der gesetzlichen Bestimmungen. Alle Anweisungen in dieser Installations- und Betriebsanleitung sind bei der Arbeit mit dem Regler zu beachten. Fehler, die durch unsachgemäße Installation, unsachgemäßen Gebrauch oder mangelhafte Wartung verursacht werden, führen zum Erlöschen der Herstellerhaftung.



Jeder Reparaturversuch entbindet von der Verantwortung und der Verpflichtung zu Garantie und Ersatz durch den Hersteller. 2012/19/EU (WEEE-Richtlinie): Produkte, die mit diesem Symbol gekennzeichnet sind, dürfen in der Europäischen Union nicht als unsortierter Siedlungsabfall entsorgt werden. Für ein ordnungsgemäßes Recycling geben Sie dieses Produkt beim Kauf eines gleichwertigen Neugeräts an Ihren örtlichen Lieferanten zurück oder entsorgen Sie es an den dafür vorgesehenen Sammelstellen. Für weitere Informationen siehe: www.stiftung-ear.de.

1.2 Anwendung

Der Regler ist für den Einsatz in Wohnräumen, Büroräumen und Industrieanlagen konzipiert. Vergewissern Sie sich vor der Inbetriebnahme, dass die Installation den geltenden Vorschriften entspricht, um eine ordnungsgemäße Nutzung der Anlage zu gewährleisten.

2. Präsentation

Der SH-HCM wurde speziell für die Regelung von Heizung und Kühlung in Kombination mit SH-CD Reglern entwickelt. Die gezielte Anwendung ist daher Wasserführende Flächenheizung und -kühlung als 2-Rohr System. Dieses Gerät ist eine Option und es ist nur ein Modul pro Anlage möglich. Es sollte in der Nähe der Heiz- und Kühlquelle (Wärmepumpe) installiert werden, während die SH-CD6-Regler in der Nähe der Verteiler installiert werden sollten. Das Gerät ist eine Option mit drei wesentlichen Nutzen:

- Separates Heiz- und Kühlsignal
- Globale Kontrolle des Luftentfeuchters
- Globale Steuerung des Heiz- und Kühlbetriebs

2.1 Funktionen

Es hat mehrere Funktionen integriert:

- Wandmontage oder Montage auf DIN-Schiene
- Steckbare Kabelverbindungen mit Zugentlastung
- LED-Statusanzeige und DIP-Schalter zur Geräteeinstellung
- H&C-Eingang (230 V und spannungsfreies Signal)
- Feuchteingang (spannungsfreier Kontakt) oder Messung der Wassertemperatur (Fühler nicht im Lieferumfang enthalten) zur Feuchteerkennung
- Leistung des Luftentfeuchters
- Pumpen- oder Kesselausgang (230 V und spannungsfreies Signal)
- Heizleistung und Kühlleistung
- Interne RF-Antenne, optionale externe Antenne

2.2 Inhalt der Box

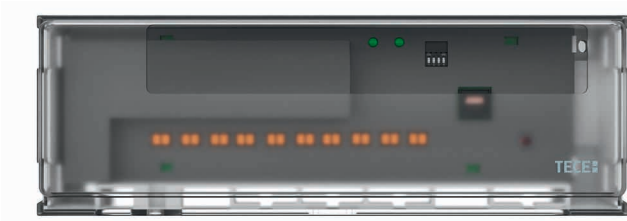

2.3 Erstmalige Installation

Es gibt zwei Möglichkeiten, den Controller zu installieren

- Wandmontage mit zwei Schrauben.
- Montiert auf einer DIN-Schiene

3. Produktbezeichnung

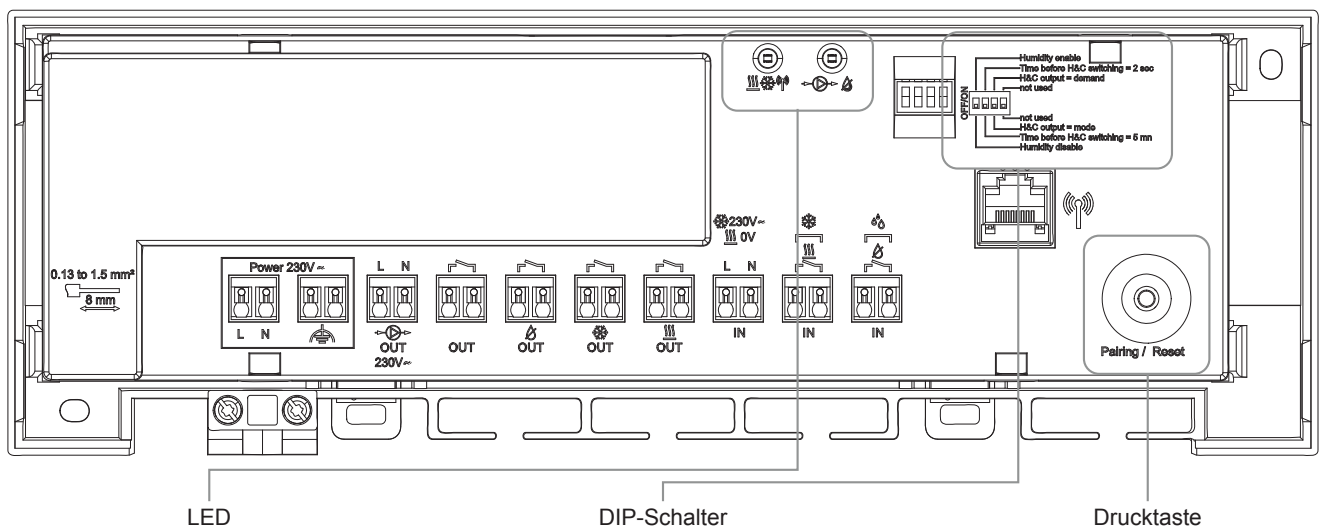

3.1 LED-Farbbedeutungen

LED	Bedeutung
Heizen und Kühlen und RF-LED (Rot/Blau/Grün)	Fix Rot = Heizbetrieb Fix Blau = Kühlbetrieb Rot/Blau blinkend = RF-Verlust (Bei RF-Verlust schaltet der SH-HCM in den Heizmodus und löst die Pumpe aus) Grün blinkend = RF-Kommunikation
LED Pumpe/Entfeuchter/Fehler (Rot/Blau/Grün)	Rot blinkend = NTC-Fehler Blau blinkend = Globale Feuchtigkeitserkennung (in diesem Fall wird der Entfeuchter ausgelöst) Fix Grün = Pumpe wird ausgelöst Grün/Blau blinkend = Globale Feuchteerkennung und Pumpenaktivierung Grün/Rot blinkend = Pumpe ist ausgelöst und NTC-Fehler Rot/Blau/Grün blinkend = Globale Feuchteerkennung und Pumpenaktivierung und NTC-Fehler

3.2 Drucktaste

10 s drücken löst den Kopplungsprozess aus
20 s drücken löst den Reset des Gerätes aus.

3.3 DIP-Schalter-Konfiguration

DIP-Schalter	Funktion	Wert (Standard: OFF)	Konfiguration	Beschreibung
DIP1	Feuchte Funktion	OFF	Deaktiviert	Siehe 4.4 und 4.5
		ON	Aktiviert	
DIP2	Heizen/Kühlen Umschaltung	OFF	5 Minuten	Siehe 4.2
		ON	2 Sekunden	
DIP3	Ausgänge Heizen und Kühlen	OFF	Gemäß Betriebsart	Siehe 4.6
		ON	Bei Anforderung	
DIP4	Feuchte Eingang	OFF	Freier Kontakteingang	Siehe 4.4
		ON	NTC-Fühler	

4. Eingänge/Ausgänge

4.1 Stromversorgung

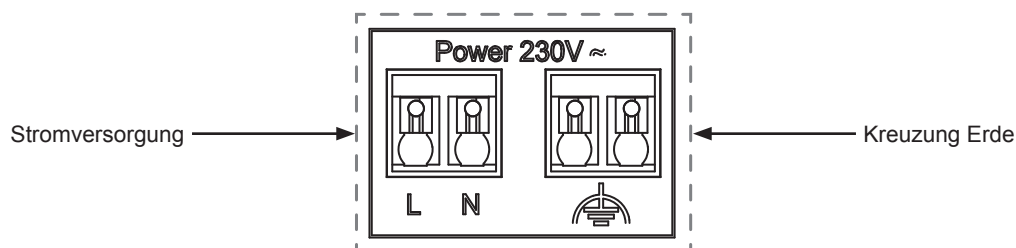

4.2 Heizung/Kühlung Eingang

Zweck: Dieser Eingang ermöglicht die Umschaltung des Regelmodus für das System: Heizen oder Kühlen.

Quelle des Signals:

- Ein mechanischer Schalter
- Eine Wärmepumpe
- Ein SH-SM, welcher mit der Zentraleinheit SH-CU als EIN/AUS-Gerät gekoppelt ist. Diese Lösung ermöglicht eine Fernsteuerung des Modus Heizen/Kühlen von der App bzw. aus dem Nutzerkonto heraus.

Format des Signals: Der Eingang kann ein freier Kontakt oder ein spannungsführender Kontakt 230 V sein.

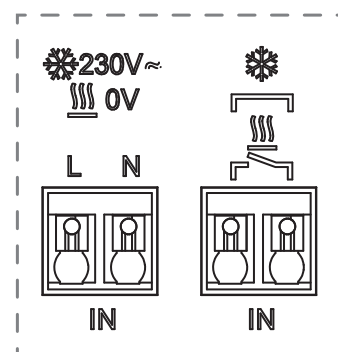

Modus	Freier Kontakt	Live-Kontakt
Heizung	Geöffnet	Kein Signal
Kühlung	Geschlossen	230 V AC

Der H&C-Modus wird auf das gesamte System übertragen.

Es sollte nur ein Gerät im System in der Lage sein, den H&C-Modus auszuwählen (Master H&C-Gerät).

Andere mögliche Signalquellen zur Umschaltung Heizen/Kühlen:

- SH-CU Zentraleinheit

- H&C-Eingang an SH-CD-Reglern
- Digitaler Thermostat, konfiguriert als Master H&C Thermostat im manuellen oder automatischen Modus.

Der DIP-Schalter auf dem Regelverteiler SH-CD ermöglicht die Auswahl des Gerätes, das für den H&C-Modus zuständig ist (Master H&C-Gerät)

Die Verzögerung zwischen H&C-Umschaltung wird über den DIP2 definiert (siehe 3.3)

- DIP2 = OFF: 5 Minuten
- DIP2 = ON: 2 Sekunden

4.3 Pumpenleistung

Es gibt zwei Ausgänge:

- Ausgang mit stromführendem Kontakt (230 V AC)
- Potenzialfreier Ausgang

Diese Ausgänge können folgende Geräte schalten:

- Ein Zonenventil
- Eine Pumpe
- Einen Heizkessel oder eine Wärmepumpe

Die zwei Ausgänge werden ausgelöst, wenn ein Heiz- oder Kühlbedarf besteht, der vom Regler SH-CD an den SH-HCM gesendet wird.

Das Pumpensignal ist immer global, d.h. die Pumpe wird eingeschaltet, wenn im System ein Heiz- oder Kühlbedarf besteht. Bei einem RF-Ausfall wird die Pumpe ständig eingeschaltet.

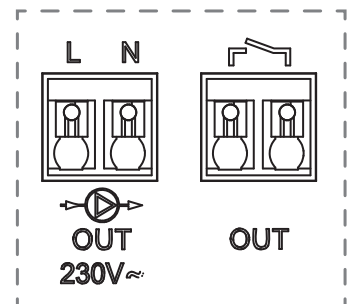

4.4 Eingang Feuchteerkennung

Wenn DIP1 = ON (siehe 3.3) verwaltet das Gerät einen Eingang zur Erkennung der Luftfeuchte, mit zwei möglichen Signaltypen, abhängig von DIP4 (siehe 3.3):

- Wassertempersensoren (NTC 10 kΩ): Erfordert SH-DTH Thermostat
- Ein Feuchtigkeitssensorkontakt

Feuchte Kontakt Fühler (Taupunktregler)

Format des Signals: Der Eingang ist ein freier Kontakt

Keine Luftfeuchtigkeit	Geöffneter Kontakt
Luftfeuchtigkeit erkannt	Geschlossener Kontakt

Wenn der Fühler Feuchte erkennt, wird die Information an den SH-CD Regler gesendet, der die Informationen verwaltet. Außerdem wird der Ausgang des Luftentfeuchters aktiviert.

Sensor für die Wassertemperatur

Die gemessene Wassertemperatur wird an alle SH-CD Regler gesendet, um den Taupunkt für die Feuchteregelung im Kühlbetrieb zu berechnen (Bitte beachten Sie die Anleitung des SH-CD)

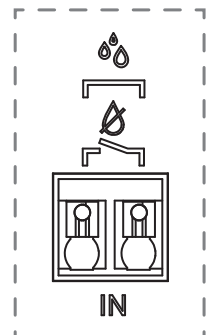

4.5 Ausgang Luftentfeuchter

Wenn DIP1 = ON (siehe 3.3), wird der Ausgang des Entfeuchters (freier Kontakt) in zwei Fällen ausgelöst:

- Wenn der Eingang Luftfeuchtigkeit ausgelöst wird (siehe 4.4)
- Wenn der Regelverteiler SH-CD den Entfeuchter anfordert

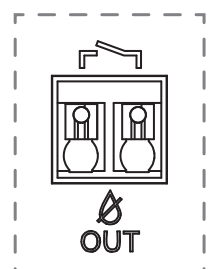

4.6 Heizen und Kühlen Ausgänge

Das Verhalten der Ausgänge (Freier Kontakt) ist abhängig vom DIP3 (siehe 3.3):

- DIP3 = OFF: Der Ausgang „Heizen“ oder „Kühlen“ wird je nach Betriebsart der Anlage (Heizen oder Kühlen) ständig aktiviert.
- DIP3 = ON: Der Heiz-/Kühlausgang wird aktiviert, wenn in der Anlage ein Heiz- oder Kühlbedarf besteht.

Bei einem RF-Ausfall wird der Heizungsausgang ständig aktiviert.

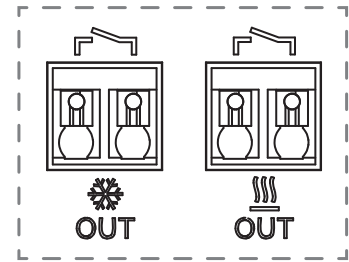

4.7 Externe Antenne

Der Abstand zwischen zwei Geräten mit interner Antenne sollte mindestens 50 cm betragen.

Im Regler ist eine interne Antenne eingebaut. Falls erforderlich, kann eine externe Antenne angeschlossen werden, um die RF-Kommunikation zu verbessern. Dies kann sinnvoll sein, wenn der Regler in einem Metallgehäuse installiert ist. In diesem Fall müssen Sie die externe Antenne außerhalb des Metallgehäuses installieren.

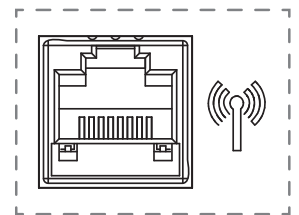

Bitte beachten Sie die Hinweise zur Montage, um die Reichweite zu optimieren und Funktionsstörungen zu vermeiden.

Die Antenne muss wie folgt installiert werden:

- außerhalb des Metallgehäuses
- in vertikaler Position und
- mindestens 50 cm von Metallteilen entfernt

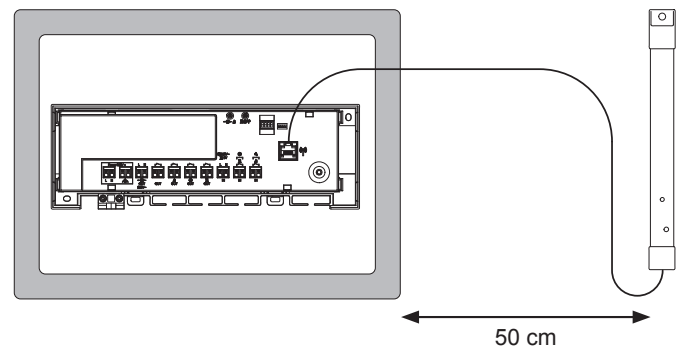

5. Systemkonfiguration

Der SH-HCM sollte immer mit einer SH-CD Steuerung gekoppelt werden, auch wenn Sie eine SH-CU verwenden. Es gibt immer nur einen SH-HCM pro Anlage.

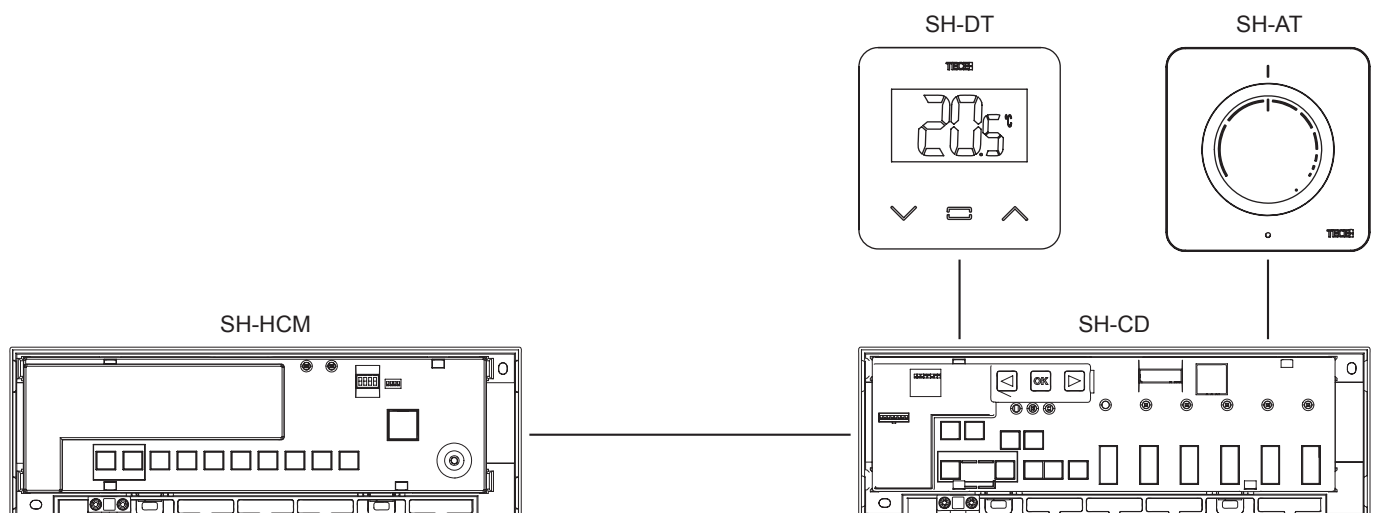

Gerät 1: SH-HCM	Gerät 2: SH-CD6-230	Bemerkungen
 <p>Versetzen Sie das Gerät in den RF-Kopplungsmodus. Drücken Sie die Taste für zehn Sekunden.</p>	 <p>Durch Drücken von OK für fünf Sekunden, wechselt der Regler in den RF-Kopplungsmodus.</p> <p>Wählen Sie mit ◀ oder ▶ die Zone 3 (LED blinkt rot) und drücken Sie OK um in den Modus „Kopplung mit Zusatzgerät“ zu gelangen.</p> <p>Alle LEDs blinken grün.</p>	<p>Wenn die Verbindung hergestellt ist, kehrt der SH-CD in das Menü für die RF-Kopplung zurück, und der SH-HCM kehrt in den normalen Modus zurück.</p>

6. Fehlersuche

Symptom	Probleme	Beschreibung	Fehlersuche
Rotes/blauges Blinken von Heat und Cool und RF LED	RF-Problem	Der SH-HCM hat die Verbindung mit dem SH-CD verloren.	<p>Prüfen Sie den Abstand zwischen den Geräten. Wenn das Gerät in einem Metallgehäuse installiert ist, verwenden Sie eine externe Antenne, die sich außerhalb des Metallgehäuses befindet. Eine externe Antenne ist auch bei einer großen Entfernung zwischen den Geräten nützlich.</p> <p>Die Verwendung einer externen Antenne auf dem SH-CD und SH-HCM verbessert die RF-Kommunikation.</p> <p>Die Verwendung eines Repeaters, der mit dem SH-CD gekoppelt ist, kann erforderlich sein.</p>
Rotes Blinken der LED Pumpe/Luftfeuchtigkeit	NTC-Fehler	Wenn DIP4 = ON ist, sollte ein Wassertempersensord an den Feuchteingang angeschlossen werden.	DIP4-Einstellung und NTC überprüfen

7. Technische Merkmale

7.1 Technische Daten

	SH-HCM
Elektrischer Schutz	Klasse II mit Funktionserde
IP-Schutz	IP 30
Versand- und Lagertemperatur	-10 °C bis 50 °C (14 °F bis 122 °F)
Stromversorgung	230 V AC ± 10 % 50 Hz
Maximale Ausgangslast (5 Ausgänge)	Relais: 5 A
Kompatibilität	SH-CD6-24, SH-CD10-24, SH-CD6-230, SH-CD10-230

7.2 Abmessungen und Gewicht

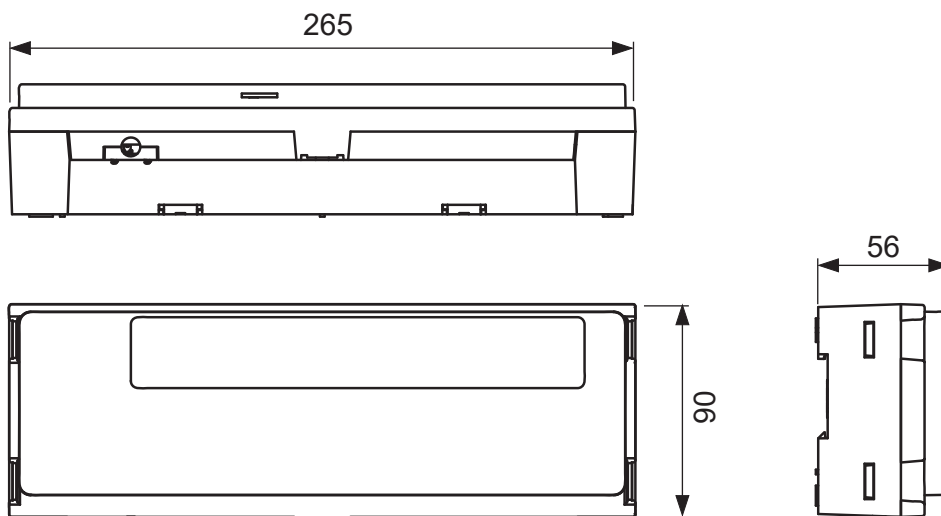

Gewicht: 820 g

8. Richtlinien

Bezeichnung	Beschreibung	Link
Niederspannungsrichtlinie (LVD)	Die Niederspannungsrichtlinie (2014/35/EU) stellt sicher, dass elektrische Betriebsmittel innerhalb bestimmter Spannungsgrenzen ein hohes Schutzniveau für die europäischen Bürgerinnen und Bürger bieten und die Vorteile des Binnenmarktes voll ausschöpfen.	2014/35/UE
Elektromagnetische Verträglichkeit (EMV) Richtlinie 2014/30/EU	Die Richtlinie 2014/30/EU über die elektromagnetische Verträglichkeit (EMV) stellt sicher, dass elektrische und elektronische Geräte keine elektromagnetischen Störungen erzeugen bzw. von diesen nicht beeinträchtigt werden.	2014/30/UE
Beschränkung der Verwendung bestimmter Richtlinie über gefährliche Stoffe (RoHS) 2011/65/ EU	Richtlinie zur Beschränkung der Verwendung bestimmter gefährliche Stoffe in elektrischen und elektronischen Geräten.	2011/65/EU
Abfall Elektrisch & Elektronische Ausrüstung Richtlinie (WEEE)	Die WEEE-Richtlinie (2012/19/EU) zielt darauf ab, die Menge an Elektro- und Elektronik-Altgeräten zu reduzieren, die auf Deponien landen.	2012/19/EU
Kommission für Ökodesign Verordnung	Ökodesign-Anforderungen für lokale Raumheizgeräte.	2015/1188
Funkanlagenrichtlinie (RED) 2014/53/ EU	Die Funkanlagenrichtlinie 2014/53/EU (RED) legt einen Rechtsrahmen für das Inverkehrbringen von Funkanlagen fest.	2014/53/EU

Content

1. General information	12
1.1 Safety warnings and operating instructions	12
1.2 Application	12
2. Presentation	12
2.1 Functions	12
2.2 Box content	13
2.3 First installation	13
3. Product description	13
3.1 LED color meanings	13
3.2 Push button	14
3.3 DIP switch configuration	14
4. Inputs / outputs	14
4.1 Power Supply	14
4.2 Heating/cooling Input	14
4.3 Pump Output	15
4.4 Humidity detection input	15
4.5 Dehumidifier output	15
4.6 Heating and cooling outputs	16
4.7 External antenna	16
5. System configuration	16
6. Trouble Shooting	17
7. Technical characteristics	17
7.1 Technical Data	17
7.2 Dimensions and weight	18
8. Directives	18

1. General information

1.1 Safety warnings and operating instructions

This product should be installed preferably by a qualified professional. Subject to observation of the above terms, the manufacturer shall assume the liability for the equipment as provided by legal stipulations. All instructions in this Installation & Operation manual should be observed when working with the controller. Failures due to improper installation, improper use or poor maintenance are voiding manufacturer liability.



Any attempt to repair voids the responsibility and the obligation to guarantee and replacement from the manufacturer.

2012/19/EU (WEEE directive): Products marked with this symbol cannot be disposed of as unsorted municipal waste in the European Union. For proper recycling, return this product to your local supplier upon the purchase of equivalent new equipment, or dispose of it at designated collection points. For more information see: www.recyclethis.info

1.2 Application

The controller has been designed for use in residential rooms, office spaces and industrial facilities. Verify that the installation complies with existing regulations before operation to ensure proper use of the installation.

2. Presentation

The SH-HCM is especially designed to control heating and cooling in combination with SH-CD controllers. The targeted application is thus 2 pipes multi zones water floor heating and cooling. This device is an option and only one module is possible per installation. It should be installed near the heating and cooling source (heat pump) whereas the SH-CD6 controllers should be installed near the manifolds. The device is an option with 3 main value proposals:

- Separate heating and cooling signal
- Global dehumidifier control
- Global Heating & cooling mode control

2.1 Functions

It has integrated multiple functions:

- Wall mounted or mounted on DIN Rail
- Push-in cable connections with strain relief
- LED status indication and DIP switch for device setting
- H&C input (230 V and volt free signal)
- Humidity input (Volt free contact) or water temperature measurement (Probe not supplied) for humidity detection
- Dehumidifier output
- Pump or boiler output (230 V and volt free signal)
- Heating output and cooling output
- Internal RF antenna, optional external antenna

2.2 Box content

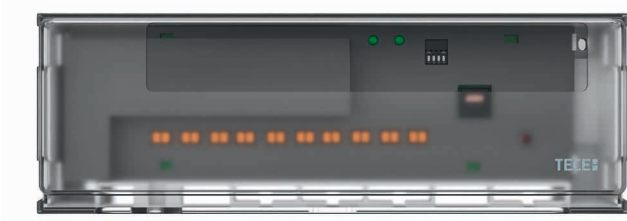

2.3 First installation

There are 2 ways to install the controller

- Wall mounted using 2 screws.
- Mounted on a DIN Rail

3. Product description

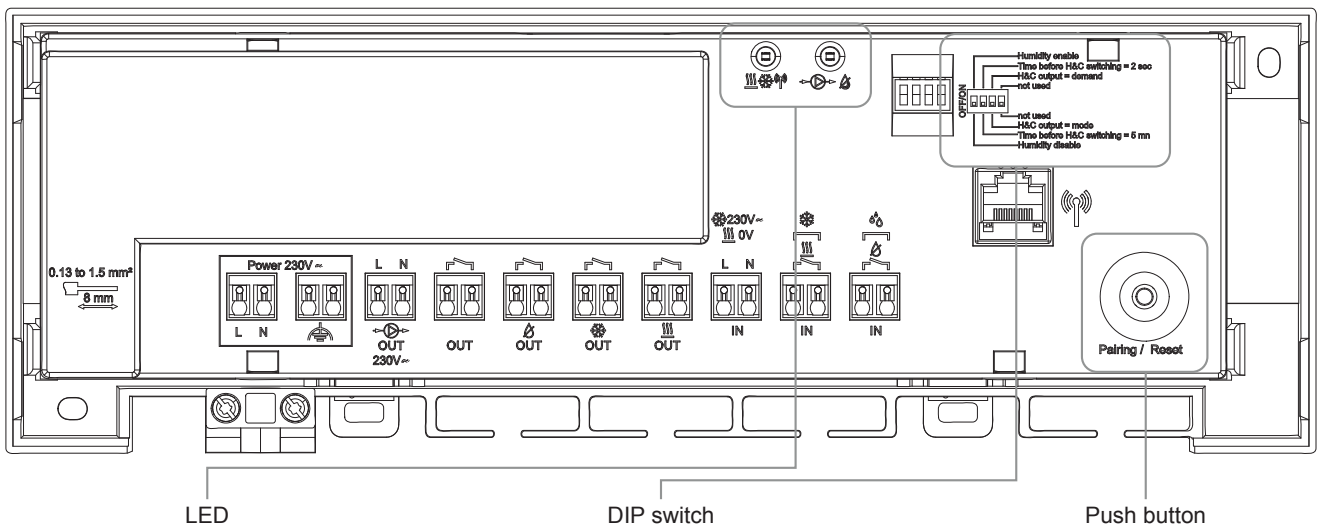

3.1 LED color meanings

LED	Meaning
Heat and Cool and RF LED (Red/Blue/Green)	Fix Red = Heating mode
	Fix Blue = Cooling mode
	Red / Blue blinking = RF loss (In case of RF loss, the SH-HCM switches in Heating mode and triggers the pump)
	Green flashing = RF communication
Pump/Humidity/error LED (Red/Blue/Green)	Red blinking = NTC error
	Blue blinking = Global humidity detection (In that case, the dehumidifier is triggered)
	Fix Green = Pump is triggered
	Green/Blue blinking = Global humidity detection and pump activation
	Green/red blinking = Pump is triggered and NTC error
	Red/Blue/Green blinking = Global humidity detection and pump activation and NTC error

3.2 Push button

10 s press triggers the pairing process.
20 s press triggers the device reset.

3.3 DIP switch configuration

DIP switch number	Function	Value (default: OFF)	Configuration	Description
DIP1	Humidity activation	OFF	Disable	See 4.4 and 4.5
		ON	Enable	
DIP2	H&C switch	OFF	5 minutes	See 4.2
		ON	2 seconds	
DIP3	H&C output mode	OFF	Mode	See 4.6
		ON	Demand	
DIP4	Humidity input	OFF	Free contact input	See 4.4
			NTC sensor	

4. Inputs / outputs

4.1 Power Supply

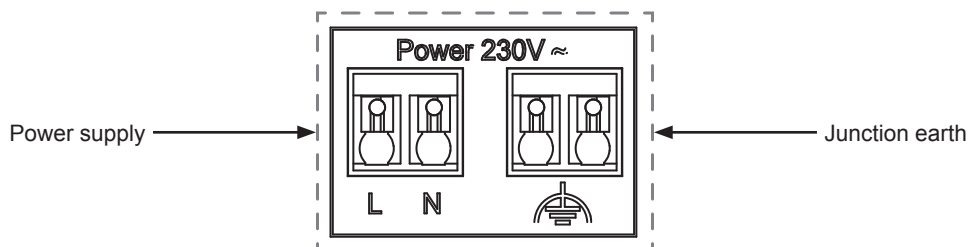

4.2 Heating/cooling Input

Purpose: This input allows switching the regulation mode for the system: Heating or cooling.

Source of the signal:

- A mechanical switch.
- The Heat Pump.
- A SH-SM paired on the SH-CU central unit as an ON/OFF device. This solution allows getting a remote control of the H&C mode from the application.

Format of the signal: The input could be free contact or live contact 230 V.

Mode	Free contact	Live contact
Heating	Opened	No signal
Cooling	Closed	230 Vac

The H&C mode is then propagated over all the system.

Only one device in the system should be able to select the H&C mode (Master H&C device).

Other possible H&C switch signal sources:

- SH-CU Central unit.
- H&C input on SH-CD controllers.
- Digital thermostat configured as a Master H&C thermostat in manual or automatic mode.

The DIP switch on the SH-CD controllers allows to select the device in charge of the H&C mode (Master H&C device).

The time before H&C switch is defined by the DIP2 (See 3.3):

- DIP2 = OFF: 5 minutes
- DIP2 = ON: 2 seconds

4.3 Pump Output

There are 2 outputs:

- Live contact output (230 Vac).
- Free contact output.

These outputs can be used to trigger:

- A zone valve.
- A pump.
- A boiler or heat pump.

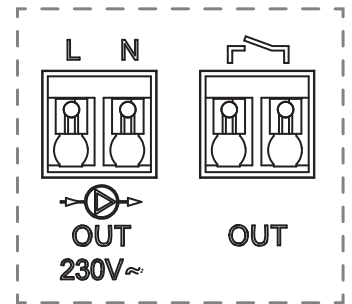

The 2 outputs are triggered when there are a heating or cooling demand, which is sent by the SH-CD controller to the SH-HCM.

The pump signal is always global, i.e. the pump is triggered when there is a heating or cooling demand within the system. If a RF failure occurs, the pump is triggered all the time.

4.4 Humidity detection input

When DIP1= ON (See 3.3) the product manages a humidity detection input, with 2 possible types of signal depending on DIP4 (See 3.3):

- Water temperature sensor (NTC 10 kΩ): Require SH-DTH thermostat.
- A humidity contact sensor.

Humidity contact sensor

Format of the signal: The input is a free contact.

No Humidity	Opened contact
Humidity detected	Closed contact

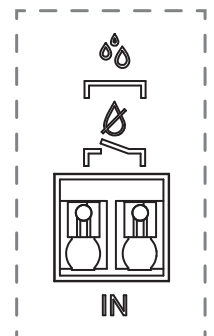

When humidity is detected by the sensor, the information is sent to the SH-CD controller which manages the information. Moreover the dehumidifier output is triggered.

Water temperature sensor

The water temperature measurement is sent to all SH-CD controllers to compute the dew point for humidity control in cooling mode (Please refer to the leaflet of SH-CD)

4.5 Dehumidifier output

When DIP1 = ON (See 3.3), the dehumidifier output (Free contact) is triggered in 2 cases:

- When the Humidity input is triggered (See 4.4).
- When the SH-CD controller orders the dehumidifier.

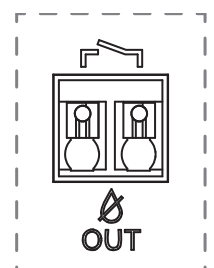

4.6 Heating and cooling outputs

The behavior of the outputs (Free contact) is dependent of the DIP3 (See 3.3):

- DIP3 = OFF: The Heating or cooling output is triggered constantly following the mode of the installation (heating or cooling).
- DIP3 = ON: The heating/cooling output is activated when there is a heating or a cooling demand in the installation.

In case of RF failure, the heating output is triggered all the time.

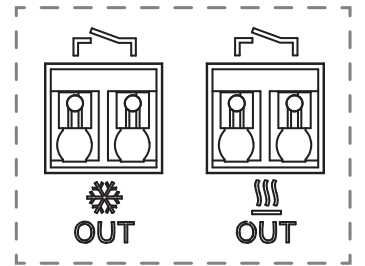

4.7 External antenna

The distance between 2 devices with internal antenna should be at least 50 cm.

The controller embeds an internal antenna. If require, an external antenna can be connected to improve the RF communication. It could be useful if the controller is installed inside a metallic box. In that case, you need to install the external antenna outside the metallic box.

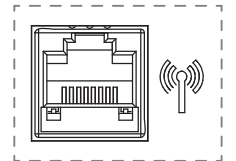

Please respect the mounting to optimize sensitivity and avoid any dysfunction

Antenna must be installed:

- outside the metallic box
- in vertical position
- and at least at 50 cm of metallic parts

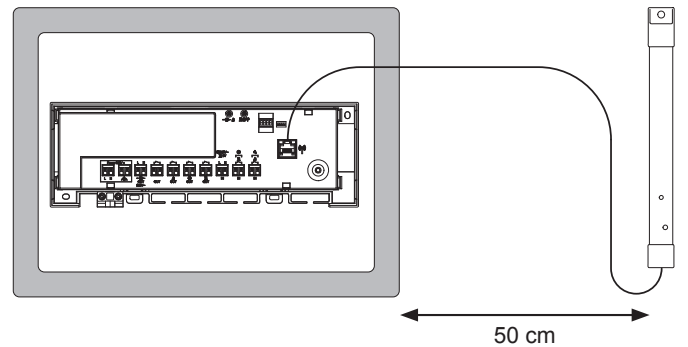

5. System configuration

The SH-HCM should be always paired to a SH-CD controller, even if you are using a SH-CU. There is always only one SH-HCM per installation.

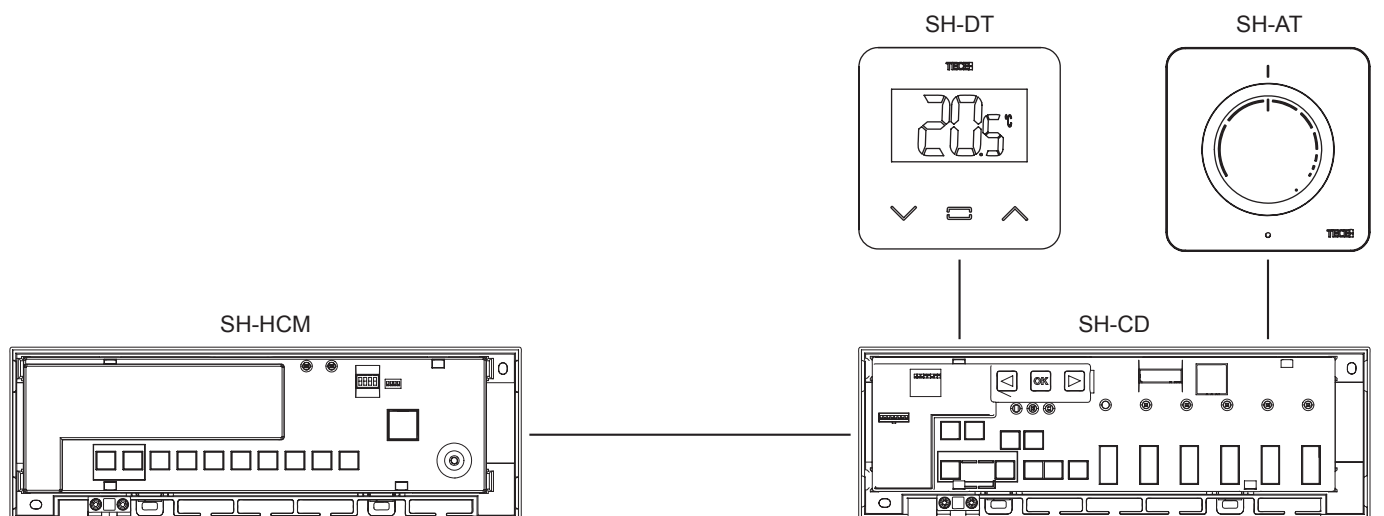

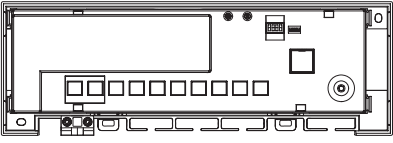
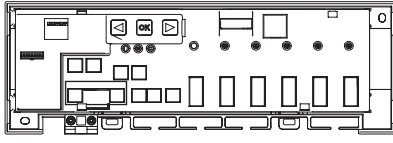
Device 1: SH-HCM	Device 2: SH-CD6-230	Remarks
 <p>Set the device to RF coupling mode. Press the button for 10 seconds.</p>	 <p>By pressing OK for 5 seconds, the controller goes in RF pairing menu. By using ◀ or ▶ select zone 3 (LED blinks red), press OK to enter in Pairing with a slave device mode. All LEDs are blinking green.</p>	When link is done, SH-CD returns to the RF pairing menu and SH-HCM returns to normal mode.

6. Trouble Shooting

Symptom	Trouble	Description	Trouble shooting
Red/Blue blinking on Heat and Cool and RF LED	RF Issue	The SH-HCM has lost the connection with the SH-CD controller.	Check distance between devices. If the device is installed within a metallic box, use an external antenna located outside the metallic box. External antenna is also useful for a long distance between devices. Usage of an external antenna on the SH-CD and SH-HCM improves the RF communication. Usage of a repeater paired to the SH-CD may be required.
Red blinking on Pump/ Humidity LED	NTC error	If DIP4 = ON, a water temperature sensor should be connected on Humidity input.	Check DIP4 setting and NTC.

7. Technical characteristics

7.1 Technical Data

	SH-HCM
Electrical protection	Class II with functional earth
IP Protection	IP30
Shipping and storage temperature	-10 °C à 50 °C (14 °F à 122 °F)
Power supply	230 Vac ± 10% 50 Hz
Output maximum load (5 outputs)	Relay: 5 A
Compatibility	SH-CD6-24, SH-CD10-24, SH-CD6-230, SH-CD10-230

7.2 Dimensions and weight

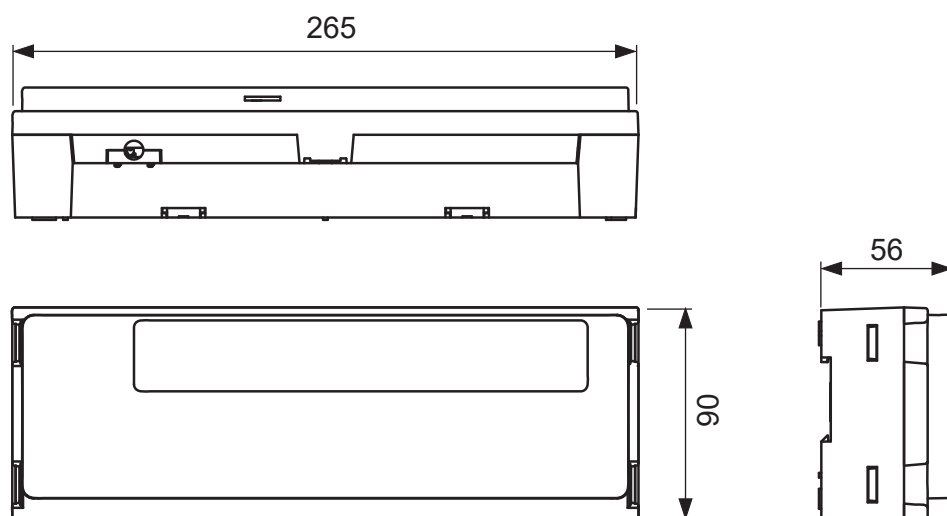

Weight: 820 g

8. Directives

Designation	Description	Link
Low Voltage Directive (LVD)	The Low Voltage Directive (LVD) (2014/35/EU) ensures that electrical equipment within certain voltage limits provides a high level of protection for European citizens, and benefits fully from the Single Market.	2014/35/UE
Electromagnetic Compatibility (EMC) Directive 2014/30/EU	The Electromagnetic Compatibility (EMC) Directive 2014/30/EU ensures that electrical and electronic equipment does not generate, or is not affected by, electromagnetic disturbance.	2014/30/UE
Restriction of the use of certain hazardous substances Directive (RoHS) 2011/65/ EU	Directive on the restriction of the use of certain hazardous substances in electrical and electronic equipment.	2011/65/EU
Waste Electrical & Electronic Equipment Directive (WEEE)	The WEEE Directive (2012/19/EU) aims to reduce the amount of waste electrical and electronic equipment that ends up in landfill.	2012/19/EU
Ecodesign Commission Regulation	Ecodesign requirements for local space heaters.	2015/1188
Radio Equipment Directive (RED) 2014/53/EU	The Radio Equipment Directive 2014/53/EU (RED) establishes a regulatory framework for placing radio equipment on the market.	2014/53/EU

Contenu

1. Informations générales	20
1.1 Avertissements de sécurité et instructions d'utilisation	20
1.2 Application	20
2. Présentation	20
2.1 Fonctions	20
2.2 Contenu de la boîte	21
2.3 Première installation	21
3. Description du produit	21
3.1 Signification de la couleur des LED	21
3.2 Bouton poussoir	22
3.3 Configuration des interrupteurs DIP	22
4. Entrées / sorties	22
4.1 Alimentation électrique	22
4.2 Entrée chauffage/refroidissement	22
4.3 Sortie de la pompe	23
4.4 Entrée de détection de l'humidité	23
4.5 Puissance du déshumidificateur	23
4.6 Sorties de chauffage et de refroidissement	24
4.7 Antenne externe	24
5. Configuration du système	24
6. Recherche de pannes	25
7. Caractéristiques techniques	25
7.1 Données techniques	25
7.2 Dimensions et poids	26
8. Directives	26

1. Informations générales

1.1 Avertissements de sécurité et instructions d'utilisation

Ce produit doit être installé de préférence par un professionnel qualifié. Sous réserve du respect des conditions susmentionnées, le fabricant assume la responsabilité de l'équipement conformément aux dispositions légales. Toutes les instructions de ce manuel d'installation et d'utilisation doivent être respectées lors de l'utilisation du contrôleur. Les défaillances dues à une mauvaise installation, à une mauvaise utilisation ou à un mauvais entretien entraînent l'annulation de la responsabilité du fabricant.



Toute tentative de réparation annule la responsabilité et l'obligation de garantie et de remplacement du fabricant.
2012/19/EU (directive DEEE) : Les produits marqués de ce symbole ne peuvent pas être éliminés comme des déchets municipaux non triés dans l'Union européenne. Pour un recyclage adéquat, renvoyez ce produit à votre fournisseur local lors de l'achat d'un nouvel équipement équivalent, ou déposez-le dans les points de collecte prévus à cet effet. Pour plus d'informations, voir : www.recyclethis.info

1.2 Application

Le contrôleur a été conçu pour être utilisé dans des pièces résidentielles, des bureaux et des installations industrielles. Vérifiez que l'installation est conforme aux réglementations en vigueur avant de la mettre en service afin d'assurer une utilisation correcte de l'installation.

2. Présentation

Le SH-HCM est spécialement conçu pour contrôler le chauffage et le refroidissement en combinaison avec les régulateurs SH-CD. L'application visée est donc le chauffage et le refroidissement de plancher d'eau multizones à 2 tuyaux. Ce dispositif est une option et un seul module est possible par installation. Il doit être installé près de la source de chauffage et de refroidissement (pompe à chaleur) tandis que les régulateurs SH-CD doivent être installés près des collecteurs. Le dispositif est une option avec 3 propositions de valeurs principales :

- Signal de chauffage et de refroidissement séparé
- Contrôle global du déshumidificateur
- Contrôle global des modes de chauffage et de refroidissement

2.1 Fonctions

Es hat mehrere Funktionen integriert:

- Montage mural ou sur rail DIN
- Raccordements de câbles avec dispositif anti traction
- Indication d'état par LED et commutateur DIP pour le réglage de l'appareil
- Entrée H&C (230 V et signal libre de potentiel)
- Entrée humidité (contact libre de potentiel) ou mesure de la température de l'eau (sonde non fournie) pour la détection de l'humidité
- Contrôle du déshumidificateur
- Sortie circulateur ou chaudière ou pompe à chaleur (230 V)
- Sortie chauffe et sortie refroidissement (signal libre de potentiel)
- Antenne RF interne, antenne externe en option

2.2 Contenu de la boîte

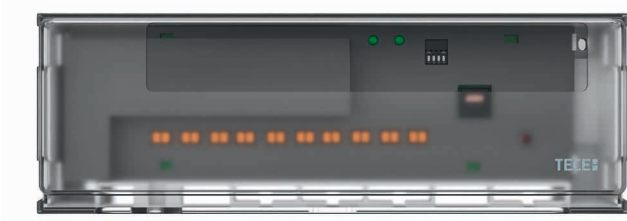

2.3 Première installation

Il y a deux façons d'installer le contrôleur

- Montage mural à l'aide de 2 vis.
- Montage sur rail DIN

3. Description du produit

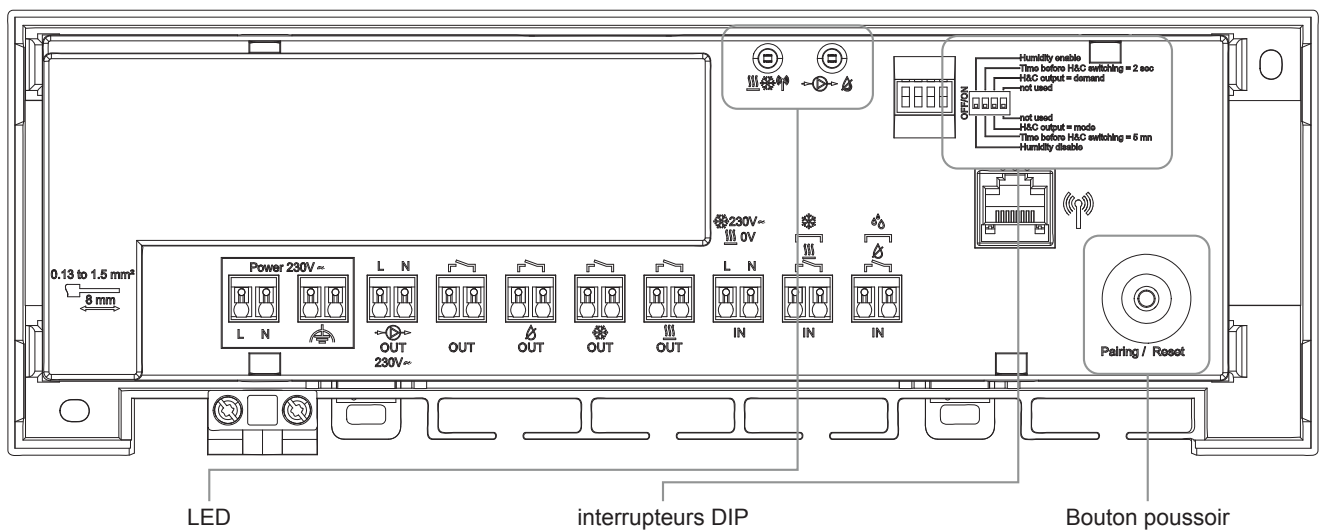

3.1 Signification de la couleur des LED

LED	Signification	
Chauffage et refroidissement et LED RF (Rouge/Bleu/Vert)	Rouge fixe =	Mode chauffage
	Bleu fixe =	Mode de refroidissement
	Rouge / Bleu clignotant =	Perte RF (En cas de perte RF, le SH-HCM passe en mode chauffage et déclenche la pompe)
	Vert clignotant =	Communication RF
LED pompe/humidité/erreur (Rouge/Bleu/Vert)	Rouge clignotant =	Erreur CTN
	Bleu clignotant =	Détection globale d'humidité (dans ce cas, le déshumidificateur est déclenché)
	Vert fixe =	Le circulateur est déclenchée
	Vert/Bleu clignotant =	Détection globale de l'humidité et activation du circulateur
	Vert/Rouge clignotant =	Déclenchement de la pompe et erreur CTN
	Rouge/Bleu/Vert clignotant =	Détection globale de l'humidité, activation du circulateur et erreur CTN

3.2 Bouton poussoir

Une pression de 10 s déclenche le processus d'appairage.
 Une pression de 20 secondes déclenche la réinitialisation de l'appareil.

3.3 Configuration des interrupteurs DIP

DIP-Schalter	Funktion	Wert (Standard: OFF)	Konfiguration	Beschreibung
DIP1	Activation de l'humidité	OFF	Désactiver	Voir 4.4 et 4.5
		ON	Activer	
DIP2	Commutateur H&C	OFF	5 minutes	Voir 4.2
		ON	2 secondes	
DIP3	Mode de sortie H&C	OFF	Mode	Voir 4.6
		ON	Demande	
DIP4	Entrée humidité	OFF	Entrée de contact libre	Voir 4.4
		ON	Capteur NTC	

4. Entrées / sorties

4.1 Alimentation électrique

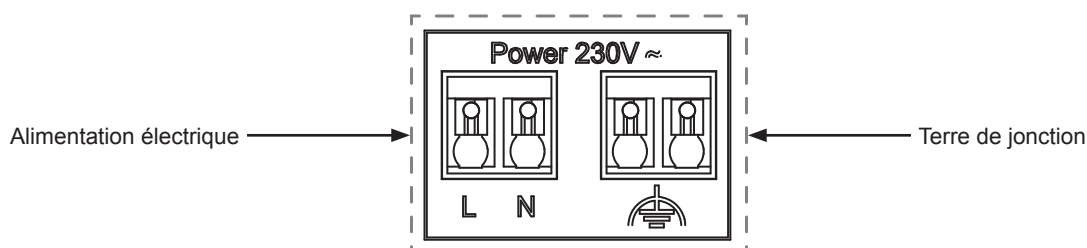

4.2 Entrée chauffage/refroidissement

Objet : Cette entrée permet de changer le mode de régulation du système : Chauffage ou refroidissement.

Source du signal :

- Un interrupteur mécanique.
- La pompe à chaleur.
- Un SH-SM couplé à l'unité centrale SH-CU/ BT-CT03 RF comme dispositif ON/OFF. Cette solution permet de contrôler à distance le mode H&C à partir de l'application.

Format du signal : L'entrée peut être à contact libre ou à contact direct 230 V.

Mode	Contact libre	Contact alimenté
Chauffage	Ouvert	Pas de signal
Refroidissement	Fermé	230 V AC

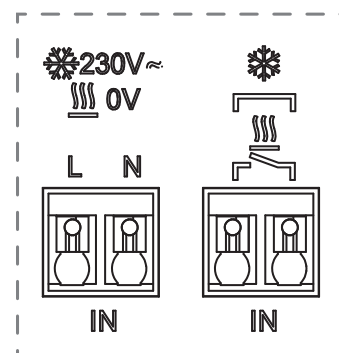

Le mode H&C est ensuite propagé à l'ensemble du système.

Un seul appareil dans le système doit pouvoir sélectionner le mode H&C (appareil H&C maître). Autres sources possibles de signaux de commutation H&C :

- SH-CU/ BT-CT03 RF Unité centrale.
- Entrée H&C sur les contrôleurs RF SH-CD.
- Thermostat digital configuré comme thermostat maître H&C en mode manuel ou automatique.

Le commutateur DIP sur les contrôleurs SH-CD permet de sélectionner l'appareil en charge du mode H&C (appareil H&C maître).

Le temps avant la commutation H&C est défini par le DIP2 (Voir 3.3) :

- DIP2 = ON : 5 minutes
- DIP2 = ON : 2 seconds

4.3 Sortie de la pompe

Il y a 2 sorties :

- Sortie contact alimenté(230 Vac).
- Sortie contact libre de potentiel

Ces sorties peuvent être utilisées pour déclencher :

- Une vanne de zone.
- Une pompe.
- Une chaudière ou une pompe à chaleur.

Les 2 sorties sont déclenchées lorsqu'il y a une demande de chauffage ou de refroidissement, qui est envoyée par le contrôleur SH-CD au SH-HCM.

Le signal de la pompe est toujours global, c'est-à-dire que la pompe est déclenchée lorsqu'il y a une demande de chauffage ou de refroidissement dans le système.

En cas de défaillance du RF, la pompe est déclenchée en permanence.

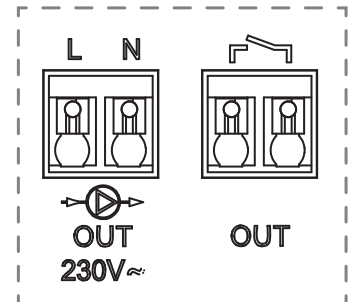

4.4 Entrée de détection de l'humidité

Lorsque DIP1= ON (voir 3.3) le produit gère une entrée de détection d'humidité, avec 2 types de signaux possibles en fonction de DIP4 (Voir 3.3) :

- Capteur de température de l'eau (CTN 10 kΩ) : Thermostat SH-DTH requis.
- Un capteur de contact d'humidité.

Capteur d'humidité à contact

Format du signal : L'entrée est un contact libre.

Pas d'humidité	Contact ouvert
Humidité détectée	Contact fermé

Lorsque l'humidité est détectée par le capteur, l'information est envoyée au contrôleur SH-CD qui gère l'information. De plus, la sortie du déshumidificateur est déclenchée.

Capteur de température de l'eau.

La mesure de la température de l'eau est envoyée à tous les contrôleurs SH-CD afin de calculer le point de rosée pour le contrôle de l'humidité en mode refroidissement (veuillez-vous référer à la notice du SH-CD).

4.5 Puissance du déshumidificateur

Lorsque DIP1 = ON (voir 3.3), la sortie du déshumidificateur (contact libre) est déclenchée dans 2 cas :

- Lorsque l'entrée Humidité est déclenchée (voir 4.4).
- Lorsque le contrôleur SH-CD commande le déshumidificateur.

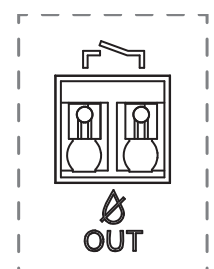

4.6 Sorties de chauffage et de refroidissement

Le comportement des sorties (contact libre) dépend du DIP3 (Voir 3.3) :

- DIP3 = OFF : La sortie chauffage ou refroidissement est déclenchée en permanence selon le mode de l'installation (chauffage ou refroidissement).
- DIP3 = ON : La sortie chauffage/refroidissement est activée lorsqu'il y a une demande de chauffage ou de refroidissement dans l'installation.

En cas de défaillance du RF, la sortie de chauffage est déclenchée en permanence.

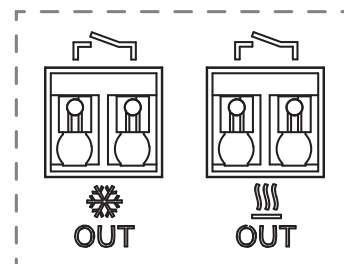

4.7 Antenne externe

La distance entre deux appareils équipés d'une antenne interne doit être d'au moins 50 cm. Le contrôleur intègre une antenne interne. Si nécessaire, une antenne externe peut être connectée pour améliorer la communication RF. Cela peut être utile si le contrôleur est installé à l'intérieur d'une boîte métallique. Dans ce cas, vous devez installer l'antenne externe à l'extérieur du boîtier métallique.

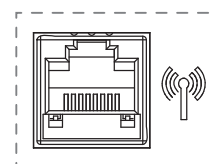

Veillez respecter le montage afin d'optimiser la sensibilité et d'éviter tout dysfonctionnement.

L'antenne doit être installée :



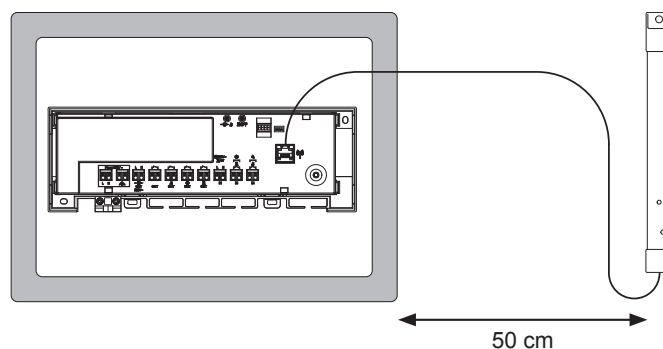

- en dehors de la boîte métallique
- en position verticale
- et au moins 50 cm de parties métalliques

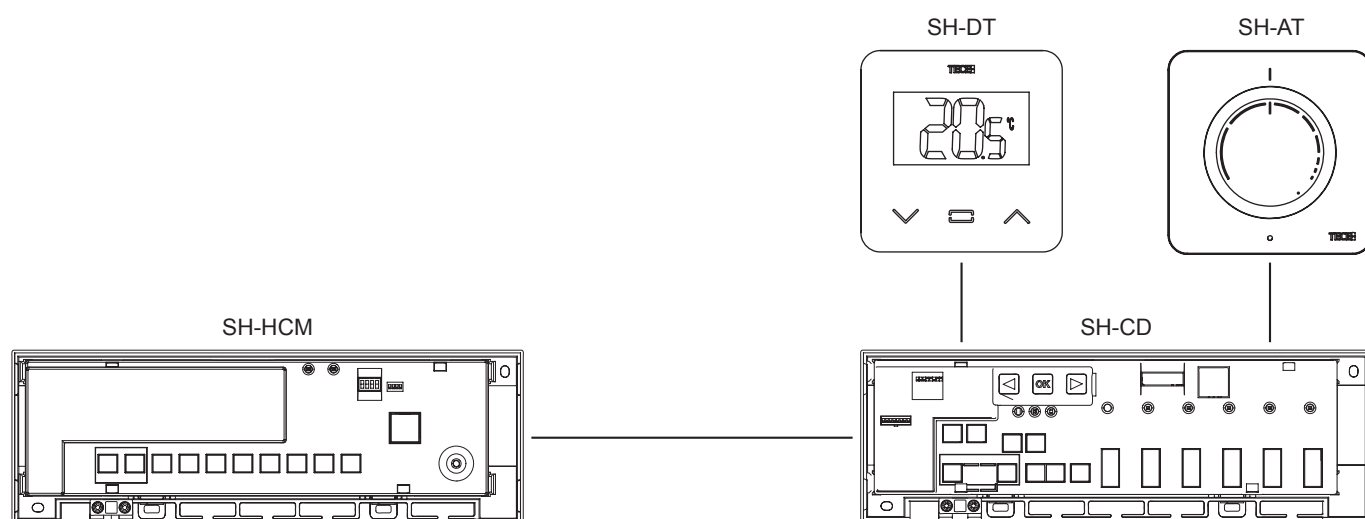

5. Configuration du système

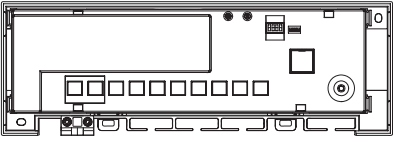
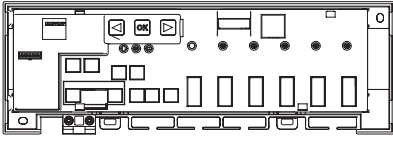
Le SH-HCM doit toujours être associé à un contrôleur SH-CD, même si vous utilisez un SH-CU. Il n'y a toujours qu'un seul SH-HCM par installation.



Dispositif 1 : SH-HCM	Dispositif 2 : SH-CD6-230	Remarques
 <p>Réglez l'appareil en mode de couplage RF. Appuyez sur le bouton pendant 10 secondes.</p>	 <p>En appuyant sur  pendant 5 secondes, le contrôleur entre dans le menu d'appairage RF. En utilisant  ou , sélectionnez la zone 3 (la LED clignote en rouge), appuyez sur  pour entrer dans le mode d'appairage avec un appareil esclave. Tous les voyants clignotent en vert.</p>	<p>Une fois la liaison effectuée, le SH-CD revient au menu d'appairage RF et le SH-HCM revient en mode normal.</p>

6. Recherche de pannes

Symptôme	Problèmes	Description	Recherche de pannes
Clignotement rouge/bleu des LED de chauffage et de refroidissement et de la LED RF	Problème relatif à la RF	Le SH-HCM a perdu la connexion avec le contrôleur SH-CD.	Vérifier la distance entre les appareils. Si l'appareil est installé dans un boîtier métallique, utilisez une antenne externe située à l'extérieur du boîtier métallique. L'antenne externe est également utile en cas de distance importante entre les appareils. L'utilisation d'une antenne externe sur le SH-CD et le SH-HCM améliore la communication RF. L'utilisation d'un répéteur couplé au SH-CD peut être nécessaire.
Clignotement rouge sur la LED Pompe/Humidité	Erreur CTN	Si DIP4 = ON, un capteur de température de l'eau doit être connecté à l'entrée Humidité.	Vérifier le réglage du DIP4 et le raccordement de la CTN.

7. Caractéristiques techniques

7.1 Données techniques

	SH-HCM
Protection électrique	Classe II avec terre fonctionnelle
Protection IP	IP30
Température d'expédition et de stockage	-10 °C à 50 °C (14 °F à 122 °F)
Alimentation électrique	230 Vac ± 10% 50 Hz
Charge maximale de la sortie (5 sorties)	Relais : 5 A
Compatibilité	SH-CD6-24, SH-CD10-24, SH-CD6-230, SH-CD10-230

7.2 Dimensions et poids

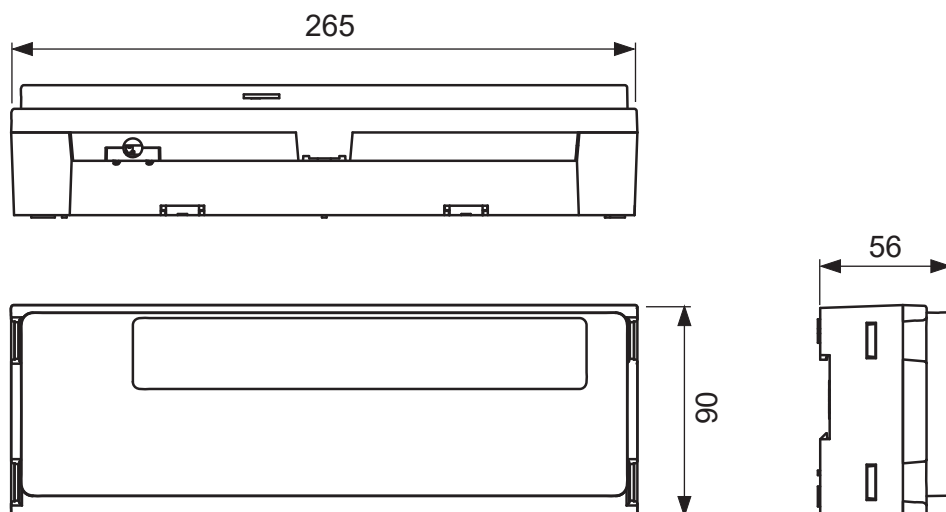

Poids : 820 g

8. Directives

Désignation	Description	Lien
Directive basse tension (DBT)	La directive basse tension (DBT) (2014/35/UE) garantit que les équipements électriques situés dans certaines limites de tension offrent un niveau de protection élevé aux citoyens européens et bénéficient pleinement du marché unique.	2014/35/UE
Compatibilité électromagnétique (CEM) Directive 2014/30/UE	La directive 2014/30/UE sur la compatibilité électromagnétique (CEM) garantit que les équipements électriques et électroniques ne génèrent pas de perturbations électromagnétiques ou ne sont pas affectés par celles-ci.	2014/30/UE
Restriction de l'utilisation de certains substances dangereuses (RoHS) Directive sur les substances dangereuses (RoHS) 2011/65/UE	Directive relative à la limitation de l'utilisation de certains substances dangereuses dans les équipements électriques et électroniques l'équipement.	2011/65/UE
Déchets électriques Équipements électroniques Directive sur les déchets d'équipements électriques et électroniques (DEEE)	La directive DEEE (2012/19/UE) vise à réduire la quantité de déchets d'équipements électriques et électroniques mis en décharge.	2012/19/UE
Commission de l'écoconception Règlement	Exigences en matière d'écoconception pour les appareils de chauffage locaux.	2015/1188
Directive relative aux équipements hertziens (RED) 2014/53/UE	La directive 2014/53/UE relative aux équipements hertziens (RED) établit un cadre réglementaire pour la mise sur le marché des équipements hertziens.	2014/53/UE

Índice

1. INFORMACIÓN GENERAL	28
1.1 Advertencias de seguridad e instrucciones de uso	28
1.2 Aplicación	28
2. PRESENTACIÓN	28
2.1 Funciones	28
2.2 Contenido de la caja	29
2.3 Primera instalación	29
3. DESCRIPCIÓN DEL PRODUCTO	29
3.1 Significado del color del LED (en rojo)	29
3.2 Pulsador (en verde)	30
3.3 Configuración del interruptor DIP (En naranja)	30
4. ENTRADAS / SALIDAS	30
4.1 Fuente de alimentación	30
4.2 Heizung/Kühlung Eingang	30
4.3 Salida de la bomba	31
4.4 Entrada de detección de humedad	31
4.5 Salida del deshumidificador	31
4.6 Potencia de calefacción y refrigeración	32
4.7 Antena exterior	32
5. CONFIGURACIÓN DEL SISTEMA	32
6. RESOLUCIÓN DE PROBLEMAS	33
7. CARACTERÍSTICAS TÉCNICAS	33
7.1 Datos técnicos	33
7.2 Dimensiones y peso	34
8. DIRECTIVAS	34

1. INFORMACIÓN GENERAL

1.1 Advertencias de seguridad e instrucciones de uso

Este producto debe ser instalado preferentemente por un profesional cualificado. Sujeto a la observación de los términos anteriores, el fabricante asumirá la responsabilidad del equipo según lo dispuesto por las estipulaciones legales. Todas las instrucciones de este manual de instalación y funcionamiento deben ser observadas cuando se trabaje con el controlador. Los fallos debidos a una instalación incorrecta, un uso inadecuado o un mantenimiento deficiente anulan la responsabilidad del fabricante.



Cualquier intento de reparación anula la responsabilidad y la obligación de garantía y sustitución por parte del fabricante. 2012/19/UE (Directiva RAEE): Los productos marcados con este símbolo no pueden eliminarse como residuos urbanos sin clasificar en la Unión Europea. Para un reciclaje adecuado, devuelva este producto a su proveedor local tras la compra de un equipo nuevo equivalente, o deséchelo en los puntos de recogida designados. Para más información, consulte en: www.recyclethis.info

1.2 Aplicación

El controlador ha sido diseñado para su uso en habitaciones residenciales, espacios de oficina e instalaciones industriales. Verifique que la instalación cumple la normativa vigente antes de ponerla en funcionamiento para garantizar un uso adecuado de la misma.

2. PRESENTACIÓN

El SH-HCM está especialmente diseñado para controlar la calefacción y la refrigeración en combinación con los controladores SH-CD. La aplicación prevista es, por tanto, calefacción y refrigeración por suelo radiante de 2 tuberías y varias zonas. Este dispositivo es una opción y sólo es posible un módulo por instalación. Debe instalarse cerca de la fuente de calefacción y refrigeración (bomba de calor), mientras que los controladores SH-CD6 deben instalarse cerca de los colectores. El dispositivo es una opción con 3 propuestas de valores principales:

- Señal separada de calefacción y refrigeración
- Control global del deshumidificador
- Control global de los modos de calefacción y refrigeración

2.1 Funciones

Ha integrado múltiples funciones:

- Montaje en pared o en carril DIN
- Conexiones de cable a presión con descarga de tracción
- Indicador LED de estado e interruptor DIP para ajustar el dispositivo
- Entrada H&C (230 V y señal sin tensión)
- Entrada de humedad (contacto libre de potencial) o medición de la temperatura del agua (sonda no suministrada) para la detección de humedad
- Salida del deshumidificador
- Salida de bomba o caldera (230 V y señal sin tensión)
- Potencia calorífica y potencia frigorífica
- Antena RF interna, antena externa opcional

2.2 Contenido de la caja

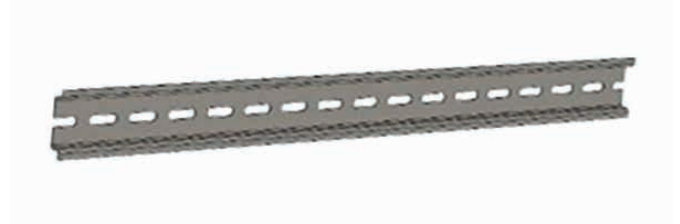
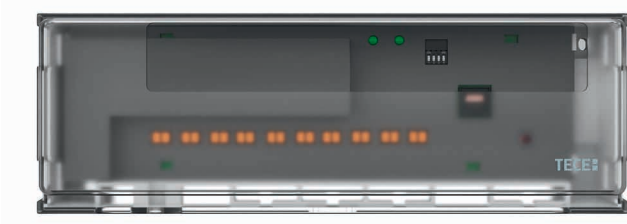

2.3 Primera instalación

Hay 2 maneras de instalar el controlador

- Montaje en pared mediante 2 tornillos.
- Montaje en carril DIN

3. DESCRIPCIÓN DEL PRODUCTO

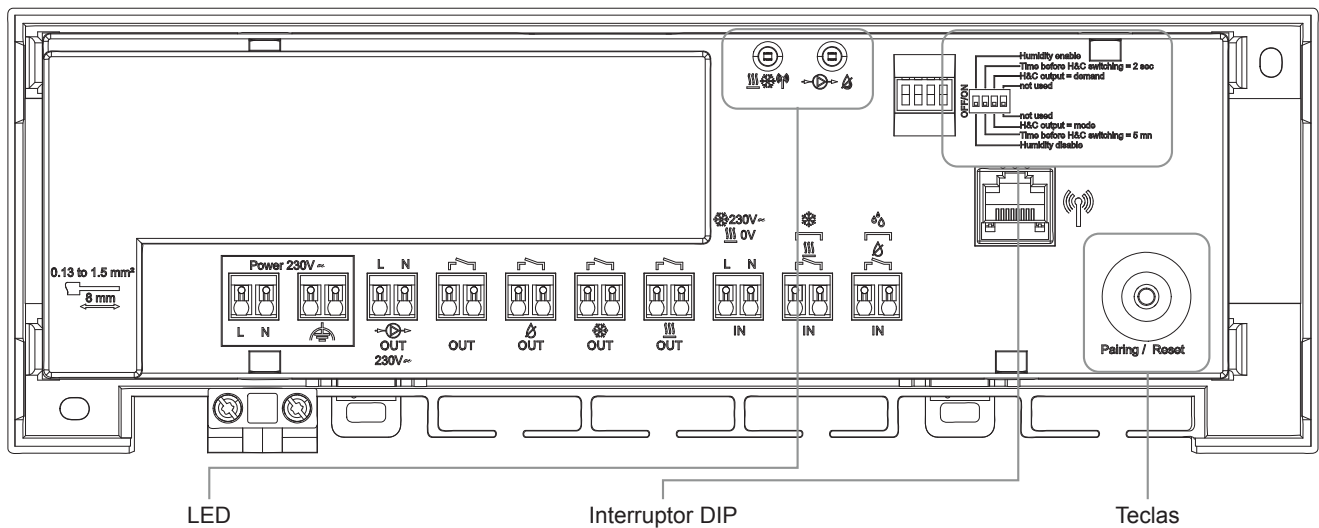

3.1 Significado del color del LED (en rojo)

LED	Significado
LED de calor y frío y RF (rojo/azul/verde)	<p>Fijar Rojo = Modo calefacción</p> <p>Fijar Azul = Modo refrigeración</p> <p>Rojo / Azul parpadeante = Pérdida de RF (En caso de pérdida de RF, la CMA-03 HCM RF 230 pasa a modo Calefacción y activa la bomba)</p> <p>Verde intermitente = Comunicación RF</p>
LED de bomba/humedad/error (Rojo/Azul/Verde)	<p>Rojo parpadeante = Error NTC</p> <p>Azul parpadeante = Detección global de humedad (En ese caso, se activa el deshumidificador)</p> <p>Fijo Verde = Bomba activada</p> <p>Verde/azul parpadeante = Detección global de humedad y activación de la bomba</p> <p>Verde/rojo parpadeante = Bomba activada y error NTC</p> <p>Rojo/Azul/Verde intermitente = Detección global de humedad y activación de la bomba y error NTC</p>

3.2 Pulsador (en verde)

Una pulsación de 10 s activa el proceso de emparejamiento.
Una pulsación de 20 s activa el reinicio del dispositivo.

3.3 Configuración del interruptor DIP (En naranja)

Número del interruptor DIP	Función	Valor (por defecto: OFF)	Configuración	Descripción
DIP1	Activación de la humedad	OFF	Desactivar	Véase 4.4 y 4.5
		ON	Activar	
DIP2	Cambio H&C	OFF	5 minutos	Véase 4.2
		ON	2 segundos	
DIP3	Modo de salida H&C	OFF	Modo	Véase 4.6
		ON	Demanda	
DIP4	Entrada de humedad	OFF	Entrada de contacto libre	Véase 4.4
			Sensor NTC	

4. ENTRADAS / SALIDAS

4.1 Fuente de alimentación

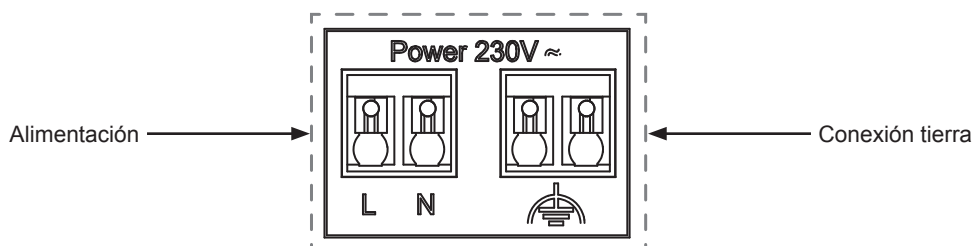

4.2 Heizung/Kühlung Eingang

Propósito:

Esta entrada permite cambiar el modo de regulación del sistema: Calefacción o refrigeración.

Fuente de la señal:

- Un interruptor mecánico.
- La bomba de calor.
- Un SH-SM emparejado en la unidad central SH-CU como dispositivo ON/OFF. Esta solución permite obtener un control remoto del modo H&C desde la aplicación.

Formato de la señal:

La entrada puede ser de contacto libre o de contacto vivo de 230 V.

Modo	Contacto gratuito	Contacto en directo
Calefacción	Abierto	No hay señal
Refrigeración	Cerrado	230 V AC

A continuación, el modo H&C se propaga por todo el sistema.

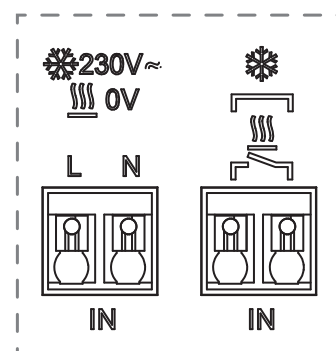

Sólo un dispositivo del sistema debe poder seleccionar el modo H&C (dispositivo H&C maestro). Otras posibles fuentes de señal de conmutación H&C:

- SH-CU Unidad central.
- Entrada H&C en los controladores SH-CD.
- Termostato digital configurado como termostato Master H&C en modo manual o automático.

El interruptor DIP de los controladores SH-CD permite seleccionar el dispositivo encargado del modo H&C (dispositivo Master H&C).

El tiempo antes de la conmutación H&C está definido por el DIP2 (Ver 3.3):

- DIP2 = OFF: 5 minutos
- DIP2 = ON: 2 segundos

4.3 Salida de la bomba

Hay dos salidas:

- Salida con contacto bajo tensión (230 V CA).
- Salida sin potencial

Estas salidas pueden conmutar los siguientes dispositivos:

- Una válvula de zona
- Una bomba
- Una caldera o bomba de calor

Las dos salidas se activan cuando hay una demanda de calefacción o refrigeración enviada desde el controlador SH-CD al SH-HCM.

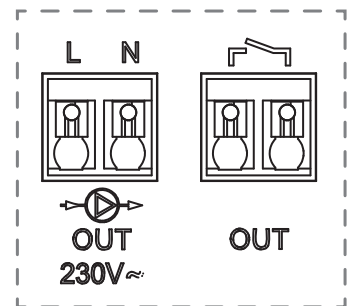

4.4 Entrada de detección de humedad

Cuando DIP1= ON (Ver 3.3) el producto gestiona una entrada de detección de humedad, con 2 posibles tipos de señal dependiendo de DIP4 (Ver 3.3):

- Sensor de temperatura del agua (NTC 10 kΩ): Requiere termostato SH-DTH.
- Un sensor de contacto de humedad.

Sensor de contacto de humedad

Formato de la señal: La entrada es un contacto libre.

Sin humedad	Contacto abierto
Humedad detectada	Contacto cerrado

Cuando el sensor detecta humedad, la información se envía al controlador SH-CD que gestiona la información. Además, se activa la salida del deshumidificador.

Sensor de temperatura del agua.

La medición de la temperatura del agua se envía a todos los controladores SH-CD para calcular el punto de rocío para el control de la humedad en modo refrigeración (consulte el folleto de SH-CD).

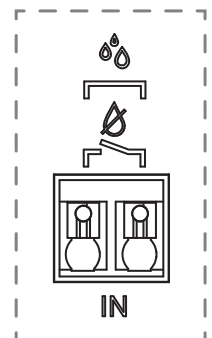

4.5 Salida del deshumidificador

Cuando DIP1 = ON (Ver 3.3), la salida del deshumidificador (Contacto libre) se activa en 2 casos:

- Cuando se activa la entrada Humedad (Ver 4.4).
- Cuando el controlador SH-CD ordena el deshumidificador.

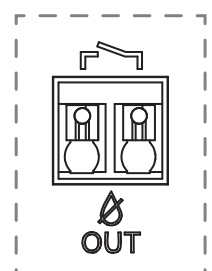

4.6 Potencia de calefacción y refrigeración

El comportamiento de las salidas (Contacto libre) depende del DIP3 (Ver 3.3):

- DIP3 = OFF: La salida Calefacción o Refrigeración se activa constantemente siguiendo el modo de la instalación (calefacción o refrigeración).
- DIP3 = ON: La salida de calefacción/refrigeración se activa cuando hay una demanda de calefacción o refrigeración en la instalación.

En caso de fallo de RF, la salida de calefacción se activa todo el tiempo.

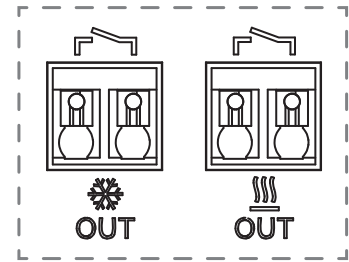

4.7 Antena exterior

La distancia entre 2 dispositivos con antena interna debe ser de al menos 50 cm.

El controlador incorpora una antena interna. Si es necesario, puede conectarse una antena externa para mejorar la comunicación por radiofrecuencia. Puede ser útil si el controlador se instala dentro de una caja metálica. En ese caso, deberá instalar la antena externa fuera de la caja metálica.



Respete el montaje para optimizar la sensibilidad y evitar cualquier disfunción

La antena debe estar instalada:

- fuera de la caja metálica
- en posición vertical
- y al menos a 50 cm de las partes metálicas

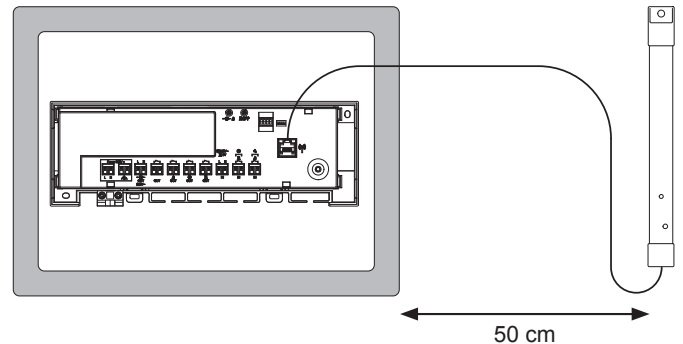

5. CONFIGURACIÓN DEL SISTEMA

El SH-HCM debe emparejarse siempre con un controlador SH-CD, incluso si está utilizando un SH-CU. Siempre hay un solo SH-HCM por instalación.

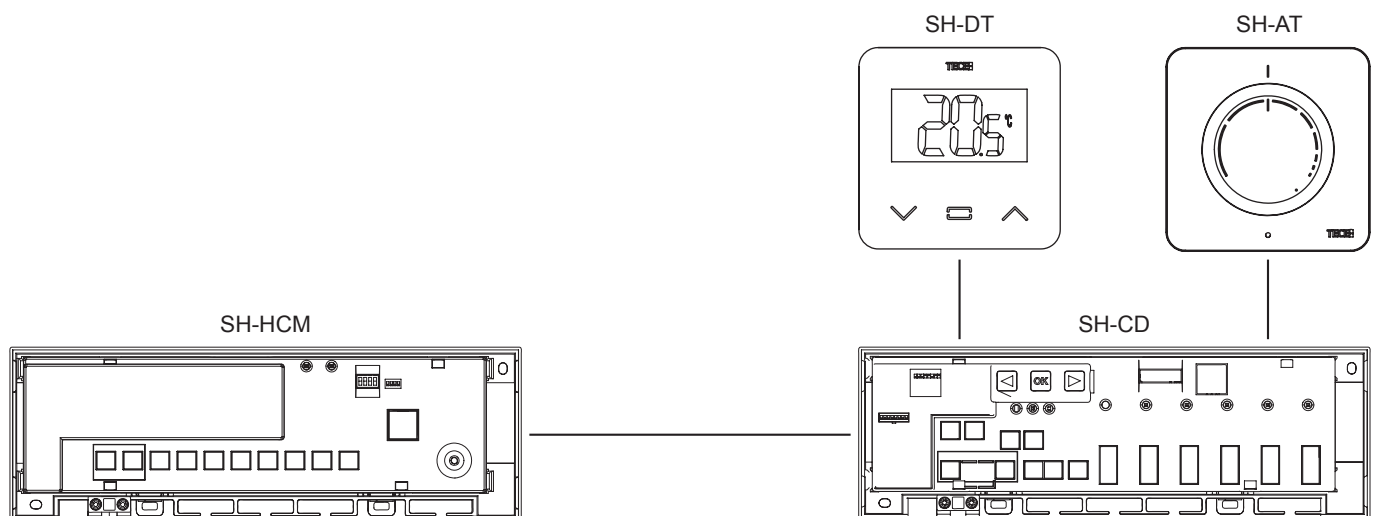

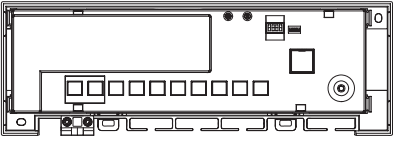
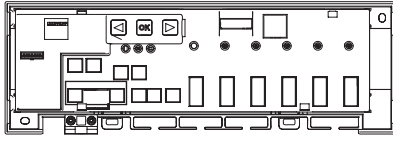
Dispositivo 1: SH-HCM	Dispositivo 2: SH-CD6-230	Observaciones
 <p>Ponga el aparato en modo de emparejamiento RF. Pulse el botón durante 10 segundos.</p>	 <p>Pulsando OK durante 5 segundos, el mando entra en el menú de emparejamiento RF.</p> <p>Mediante ◀ o ▶ seleccione la zona 3 (el LED parpadea en rojo), pulse OK para entrar en modo Emparejamiento con un dispositivo esclavo.</p> <p>Todos los LED parpadean en verde.</p>	<p>Una vez finalizado el enlace, el SH-CD vuelve al menú de emparejamiento RF y el SH-HCM vuelve al modo normal.</p>

6. RESOLUCIÓN DE PROBLEMAS

Síntoma	Problemas	Descripción	Solución de problemas
Parpadeo rojo/azul en Heat y Cool y LED RF	Problema de RF	El SH-HCM ha perdido la conexión con el controlador SH-CD.	<p>Compruebe la distancia entre dispositivos. Si el dispositivo está instalado dentro de una caja metálica, utilice una antena externa situada fuera de la caja metálica. La antena externa también es útil para distancias largas entre dispositivos.</p> <p>El uso de una antena externa en el SH-CD y SH-HCM mejora la comunicación RF.</p> <p>Puede ser necesario el uso de un repetidor emparejado a la SH-CD.</p>
Parpadeo en rojo del LED Bomba/Humedad	Error NTC	Si DIP4 = ON, debe conectarse un sensor de temperatura del agua en la entrada Humedad.	Compruebe el ajuste del DIP4 y el NTC.

7. CARACTERÍSTICAS TÉCNICAS

7.1 Datos técnicos

	SH-HCM
Protección eléctrica	Clase II con tierra funcional
Protección IP	IP 30
Temperatura de transporte y almacenamiento	-10 °C a 50 °C (14 °F a 122 °F)
Alimentación	230 Vca ± 10 % 50 Hz
Carga máxima de salida (5 salidas)	Relé: 5 A
Compatibilidad	SH-CD6-24, SH-CD10-24, SH-CD6-230, SH-CD10-230

7.2 Dimensiones y peso

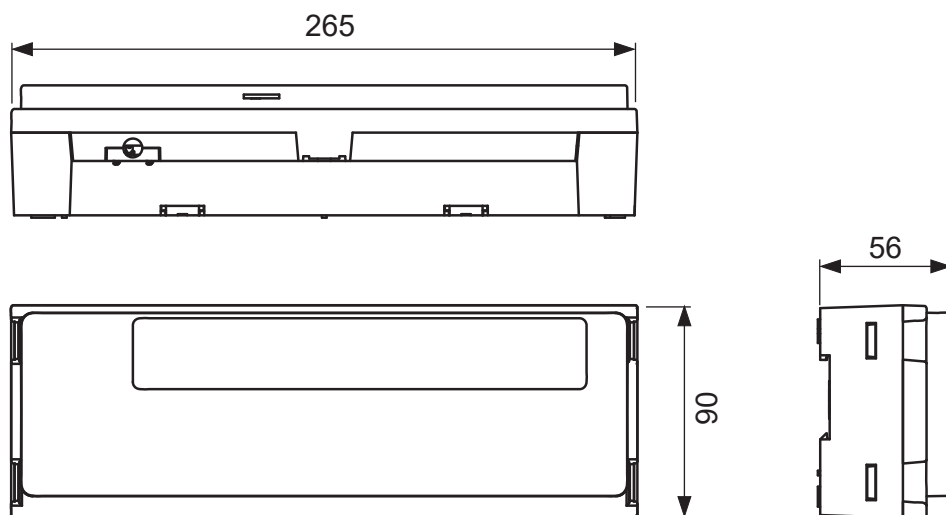

Peso: 820 g

8. DIRECTIVAS

Bezeichnung	Beschreibung	Link
Directiva de baja tensión (LVD)	La Directiva de Baja Tensión (LVD) (2014/35/UE) garantiza que los equipos eléctricos dentro de ciertos límites de tensión proporcionen un alto nivel de protección a los ciudadanos europeos y se beneficien plenamente del mercado único.	2014/35/UE
Compatibilidad electromagnética (EMC) Directiva 2014/30/UE	La Directiva de Compatibilidad Electromagnética (EMC) 2014/30/UE garantiza que los equipos eléctricos y electrónicos no generen perturbaciones electromagnéticas ni se vean afectados por ellas.	2014/30/UE
Restricción del uso de determinadas sustancias peligrosas (RoHS) 2011/65/UE	Directiva relativa a la restricción del uso de determinadas sustancias peligrosas en aparatos eléctricos y electrónicos equipo.	2011/65/EU
Residuos eléctricos & Equipos electrónicos Directiva RAEE	La Directiva RAEE (2012/19/UE) tiene como objetivo reducir la cantidad de residuos de aparatos eléctricos y electrónicos que acaban en los vertederos.	2012/19/EU
Comisión de Diseño Ecológico Reglamento	Requisitos de diseño ecológico para los calefactores locales.	2015/1188
Directiva sobre equipos radioeléctricos (DER) 2014/53/UE	La Directiva de Equipos Radioeléctricos 2014/53/UE (DER) establece un marco regulador para la comercialización de equipos radioeléctricos.	2014/53/EU

Contenuto

1. INFORMAZIONI GENERALI	36
1.1 Avvertenze di sicurezza e istruzioni per l'uso	36
1.2 Applicazione	36
2. PRESENTAZIONE	36
2.1 Funzioni	36
2.2 Contenuto della scatola	37
2.3 Prima installazione	37
3. DESCRIZIONE DEL PRODOTTO	37
3.1 Pulsante	38
3.2 Configurazione dei DIP-switch	38
4. INGRESSI / USCITE	38
4.1 Alimentazione	38
4.2 Ingresso riscaldamento/raffrescamento (H&C)	38
4.3 Uscita della pompa	39
4.4 Uscita della pompa	39
4.5 Uscita del deumidificatore	39
4.6 Uscite di riscaldamento e raffrescamento	40
4.7 Antenna esterna	40
5. Antenna esterna	40
6. RISOLUZIONE DEI PROBLEMI	41
7. CARATTERISTICHE TECNICHE	41
7.1 Dati tecnici	41
7.2 Dimensioni e peso	42
8. DIRETTIVE	42

1. INFORMAZIONI GENERALI

1.1 Avvertenze di sicurezza e istruzioni per l'uso

Questo dispositivo deve essere installato da un professionista qualificato. Ferma restando l'osservanza di quanto sopra, il produttore si assume la responsabilità del prodotto in conformità alla legislazione vigente.

Quando si opera con il modulo di controllo, seguire tutte le istruzioni contenute nel presente manuale di installazione e uso. Eventuali guasti dovuti ad errori di installazione, uso improprio o a scarsa manutenzione sollevano il produttore dalla responsabilità.



Qualsiasi tentativo di riparazione solleva il produttore dalla responsabilità e dall'obbligo di garanzia e sostituzione. 2012/19/UE (direttiva RAEE): I prodotti contrassegnati con questo simbolo non possono essere smaltiti come rifiuti urbani indifferenziati all'interno dell'Unione Europea. Per un corretto riciclaggio, restituire il prodotto al proprio fornitore di fiducia all'acquisto di un prodotto nuovo equivalente, oppure smaltire il prodotto presso i centri di raccolta preposti. Per maggiori informazioni: www.recyclethis.info

1.2 Applicazione

Il modulo di controllo è stato progettato per l'uso in ambienti residenziali, uffici e impianti industriali. Prima dell'uso, verificare che l'installazione sia conforme alle normative vigenti così da garantirne l'uso corretto.

2. PRESENTAZIONE

Il modulo SH-HCM è stato progettato appositamente per controllare il riscaldamento e il raffrescamento in combinazione con i box di collegamento SH-CD. Trova quindi applicazione in impianti a pavimento di riscaldamento e raffrescamento ad acqua a 2 tubi multizona. Questo dispositivo è un'opzione e per ogni impianto è possibile installare un solo modulo. Deve essere installato vicino alla fonte di riscaldamento e raffrescamento (pompa di calore), mentre i regolatori SH-CD devono essere installati vicino ai collettori. Il modulo è un dispositivo opzionale con 3 caratteristiche principali:

- Segnale di riscaldamento e raffrescamento separato
- Controllo globale del deumidificatore
- Controllo globale della modalità di riscaldamento e raffrescamento

2.1 Funzioni

Integra molteplici funzioni:

- Montaggio a parete o su guida DIN
- Collegamenti cavi ad innesto antistrappo
- Indicazione di stato a LED e DIP-Switch per la configurazione del dispositivo
- Ingresso H&C (230 V e segnale libero da tensione)
- Ingresso umidità (contatto libero da tensione) o misurazione della temperatura dell'acqua (sonda non fornita) per il rilevamento dell'umidità
- Uscita del deumidificatore
- Uscita pompa o caldaia (230 V e segnale libero da tensione)
- Uscita contatto pulito attivazione riscaldamento e uscita contatto pulito attivazione raffrescamento
- Antenna RF interna, antenna esterna opzionale

2.2 Contenuto della scatola

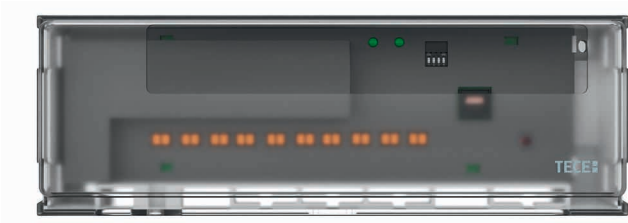

2.3 Prima installazione

Esistono due modi per installare il modulo di controllo

- Montaggio a parete con 2 viti.
- Montaggio su guida DIN

3. DESCRIZIONE DEL PRODOTTO

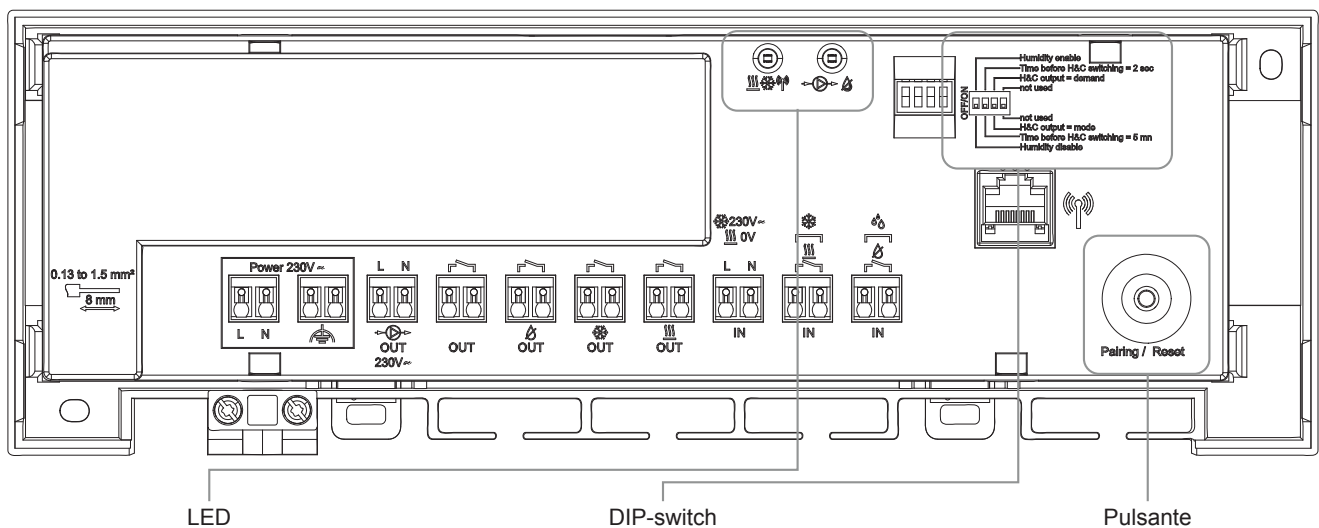

Significato dei colori dei LED

LED	Significato
LED di calore, raffreddamento e RF (Rosso/Blu/Verde)	<p>Fisso rosso = Modalità di riscaldamento</p> <p>Fisso blu = Modalità di raffreddamento</p> <p>Lampeggio rosso/blu = Perdita della comunicazione radiofrequenza (in caso di perdita di radiofrequenza, il SH-HCM passa in modalità riscaldamento e attiva la pompa).</p> <p>Verde lampeggiante = Comunicazione RF</p>
LED pompa/umidità/errore (Rosso/Blu/Verde)	<p>Lampeggio rosso = errore sonda NTC</p> <p>Lampeggio blu = Rilevamento dell'umidità globale (in questo caso viene attivato il deumidificatore)</p> <p>Verde fisso = la pompa è attivata</p> <p>Lampeggio verde/blu = Rilevamento dell'umidità globale e attivazione della pompa</p> <p>Lampeggio Verde/rosso = Pompa attivata ed errore sonda NTC</p> <p>Lampeggio Rosso/Blu/Verde = rilevamento dell'umidità globale, attivazione della pompa ed errore sonda NTC</p>

3.1 Pulsante

La pressione di 10 secondi attiva il processo di accoppiamento – Luce verde fissa del primo LED

La pressione di 20 secondi attiva il reset del dispositivo – Lampeggio Rosso e Verde di entrambi i LED

3.2 Configurazione dei DIP-switch

Numero del DIP-switch	Funzione	Valore (impostazione predefinita: OFF)	Configurazione	Descrizione
DIP1	Attivazione gestione ingresso Umidità	OwwFF	Disattivare	Vedi 4.4 e 4.5
		ON	Abilitazione	
DIP2	Tempo di commutazione modalità H&C	OFF	5 minuti	Vedi 4.2
		ON	2 secondi	
DIP3	Modalità attivazione uscite H&C	OFF	In base alla Modalità	Vedi 4.6
		ON	In base alla Domanda	
DIP4	Ingresso umidità	OFF	Ingresso a contatto libero	Vedi 4.4
		ON	Sensore NTC	

4. INGRESSI / USCITE

4.1 Alimentazione

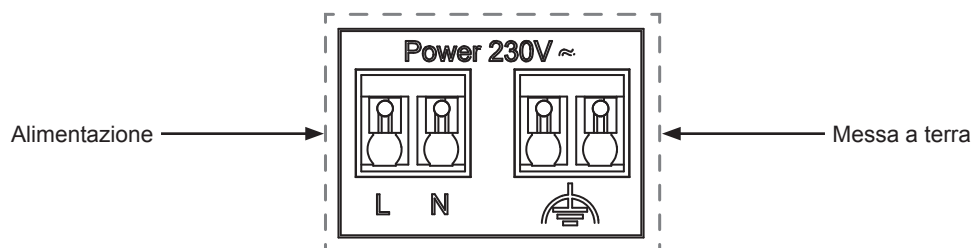

4.2 Ingresso riscaldamento/raffrescamento (H&C)

Scopo: Questo ingresso consente di commutare la modalità di regolazione del sistema: riscaldamento o raffrescamento.

Fonte del segnale:

- Un interruttore meccanico
- Una pompa di calore
- Un SH-SM accoppiato all'Unità Centrale SH-CU come dispositivo ON/OFF. Questa soluzione consente di ottenere un controllo remoto della modalità H&C dall'applicazione Watts Vision per dispositivi mobili.

Formato del segnale: L'ingresso può essere a contatto libero o in tensione a 230 V.

Modalità	Contatto libero	Contatto in tempo reale
Riscaldamento	Aperto	Nessun segnale
Raffrescamento	Chiuso	230 V AC

La modalità H&C viene quindi propagata su tutto il sistema.

Solo un dispositivo del sistema deve essere in grado di selezionare la modalità H&C (dispositivo H&C master).

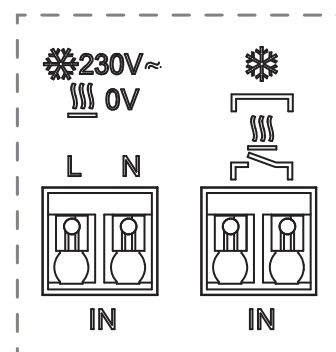

Altre possibili fonti di segnale di commutazione H&C:

- Unità centrale SH-CU
- Ingresso H&C sui box SH-CD
- Termostato digitale configurato come termostato Master H&C in modalità manuale o automatica

La configurazione dei DIP-switch dei box di collegamento SH-CD consente di selezionare il dispositivo responsabile del cambio di modalità H&C (dispositivo H&C master)

L'intervallo di tempo prima della commutazione modalità H&C è definito dal DIP2 (Vedere 3.3)

- DIP2 = OFF: 5 minuti
- DIP2 = ON: 2 secondi

4.3 Uscita della pompa

Sono presenti 2 uscite:

- Uscita contatto in tensione (230 V AC)
- Uscita a contatto libero

Queste uscite possono essere utilizzate per l'attivazione:

- Una valvola di zona
- Una pompa di circolazione
- Una caldaia o una pompa di calore

Le 2 uscite vengono attivate quando SH-HCM riceve una richiesta di riscaldamento o raffreddamento dal box di collegamento SH-CD.

Il segnale della pompa è sempre globale, cioè la pompa viene attivata quando c'è una richiesta di riscaldamento o raffreddamento all'interno del sistema.

Se si verifica un guasto RF, la pompa si attiva sempre.

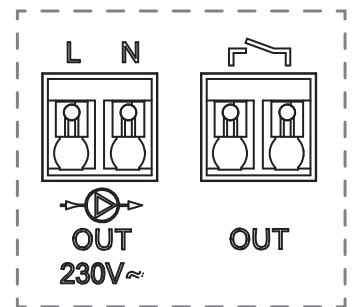

4.4 Uscita della pompa

Quando DIP1= ON (vedere 3.3) il dispositivo gestisce un ingresso per il rilevamento dell'umidità, è possibile configurare il tipo di segnale secondo la configurazione di DIP4 (vedi 3.3):

- Un sensore di contatto per l'umidità
- Sensore di temperatura dell'acqua ((NTC 10 kΩ): Richiede il termostato SH-DTH

Sensore di contatto per l'umidità

Formato del segnale: l'ingresso è un contatto libero

Nessuna umidità	Contatto aperto
Umidità rilevata	Contatto chiuso

Quando il sensore rileva l'umidità, le informazioni vengono inviate al modulo di controllo SH-CD che le gestisce. Inoltre, viene attivata l'uscita del deumidificatore.

Sensore di temperatura dell'acqua

La misura della temperatura dell'acqua viene inviata a tutti i box di collegamento SH-CD per calcolare il punto di rugiada per il controllo dell'umidità in modalità di raffreddamento (vedi manuale d'uso del SH-CD)

4.5 Uscita del deumidificatore

Secondo configurazione DIP1 = ON (vedere 3.3), l'uscita del deumidificatore (contatto libero) viene attivata se:

- viene attivato l'ingresso Umidità (vedere 4.4)
- il box di collegamento SH-CD invia richiesta di deumidifica

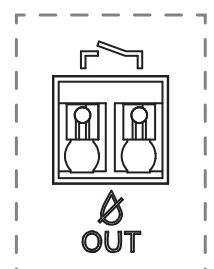
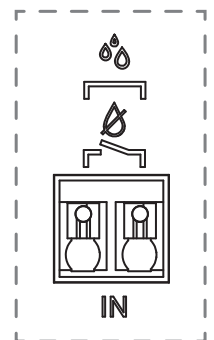

4.6 Uscite di riscaldamento e raffrescamento

Il comportamento delle uscite (contatto libero) dipende dal DIP3 (vedi 3.3):

- DIP3 = OFF: L'uscita di riscaldamento o raffrescamento viene attivata costantemente in base alla modalità di installazione (riscaldamento o raffrescamento).
- DIP3 = ON: L'uscita di riscaldamento/raffrescamento si attiva quando nell'impianto è presente almeno una richiesta di riscaldamento o di raffrescamento.

In caso di guasto RF, l'uscita di riscaldamento è sempre attivata.

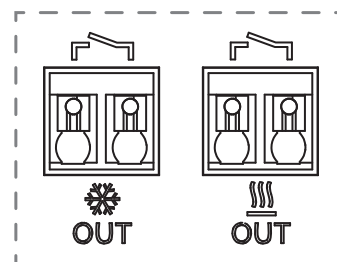

4.7 Antenna esterna

La distanza tra 2 dispositivi con antenna interna deve essere di almeno 50 cm.

Il modulo di controllo incorpora un'antenna interna. Se necessario, è possibile collegare un'antenna esterna (accessorio opzionale) per migliorare la comunicazione RF. Potrebbe essere utile se il modulo di controllo è installato all'interno di una scatola metallica. In questo caso, è necessario installare l'antenna esterna al di fuori della scatola metallica.

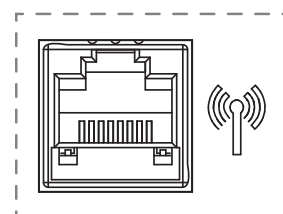

Rispettare lo schema di montaggio per ottimizzare la sensibilità ed evitare malfunzionamenti.

L'antenna deve essere installata:

- fuori dalla scatola metallica
- in posizione vertical e
- almeno 50 cm da parti metalliche.

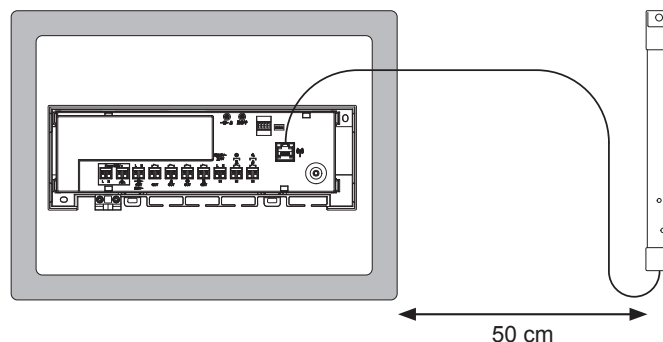

5. Antenna esterna

Il modulo SH-HCM deve essere sempre accoppiato a un box di collegamento SH-CD, anche se si utilizza l'Unità Centrale SH-CU. Per ogni impianto si può abbinare un solo SH-HCM.

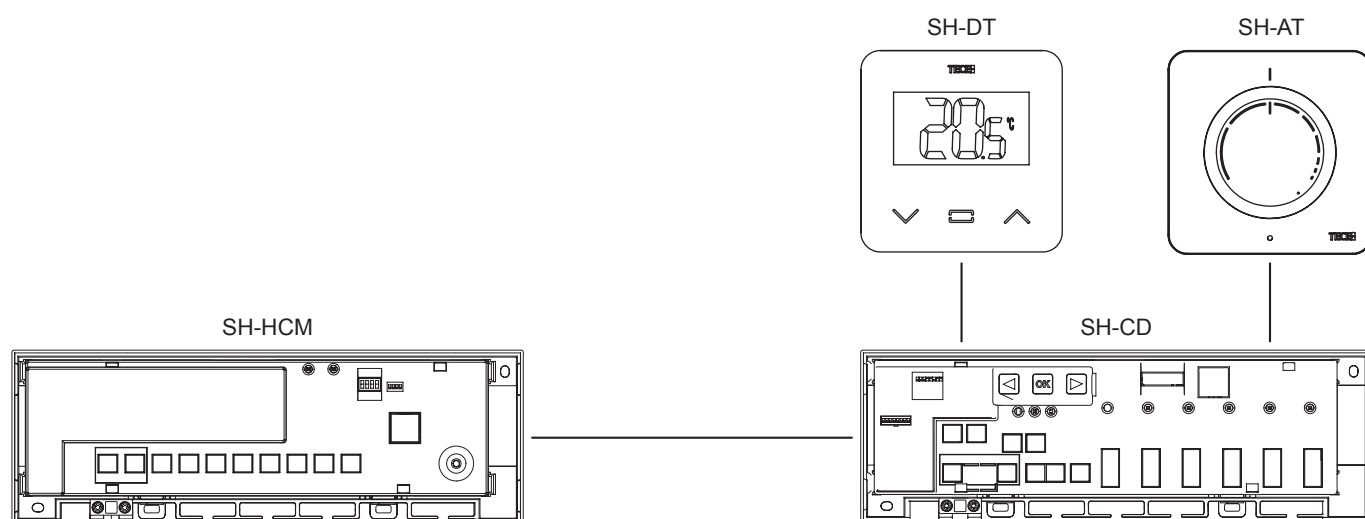

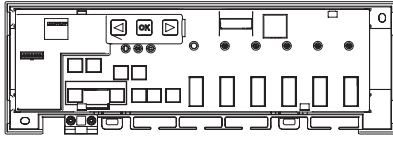
Dispositivo 1:SH-HCM	Dispositivo 2:SH-CD6-230	Osservazioni
 <p>Impostare il dispositivo in modalità di accoppiamento RF. Premere il pulsante per 10 secondi.</p>	 <p>Premendo OK per 5 secondi, il box di collegamento passa al menu di accoppiamento RF. Selezionare con ◀ o ▶ la zona 3 (il LED lampeggia in rosso), premere OK per accedere alla modalità di accoppiamento con un dispositivo slave. Tutti i LED lampeggiano in verde.</p>	<p>Al termine del collegamento, il box SH-CD torna al menu di accoppiamento RF e il modulo di controllo SH-HCM torna in normale modalità di funzionamento.</p>

6. RISOLUZIONE DEI PROBLEMI

Sintomo	Problemi	Descrizione	Risoluzione dei problemi
Lampeggio rosso/blu su LED riscaldamento/raffrescamento e LED segnale RF	Problema RF	Il SH-HCM ha perso il collegamento con il modulo di controllo SH-CD.	Verificare la distanza tra i dispositivi. Se il dispositivo è installato all'interno di una scatola metallica, utilizzare un'antenna esterna situata all'esterno della scatola metallica. L'antenna esterna è utile anche nel caso distanze elevate tra i dispositivi. L'uso di un'antenna esterna sul SH-CD e sul SH-HCM migliora la comunicazione RF. Potrebbe essere necessario l'uso di un ripetitore accoppiato al SH-CD.
Lampeggio rosso del LED pom-pa/umidità	Errore sonda NTC	Se DIP4 = ON, un sensore di temperatura dell'acqua deve essere collegato all'ingresso Umidità.	Controllare corretto collegamento e funzionamento del sensore NTC, nonché corretta l'impostazione del DIP4

7. CARATTERISTICHE TECNICHE

7.1 Dati tecnici

	SH-HCM
Protezione elettrica	Classe II con terra funzionale
Protezione IP	IP30
Temperatura di spedizione e di magazzino	-10 °C à 50 °C (14 °F à 122 °F)
Alimentazione	230 V AC ± 10 % 50 Hz
Carico massimo in uscita (5 uscite)	Relè: 5 A
Compatibilità	SH-CD6-24,SH-CD10-24,SH-CD6-230,SH-CD10-230

7.2 Dimensioni e peso

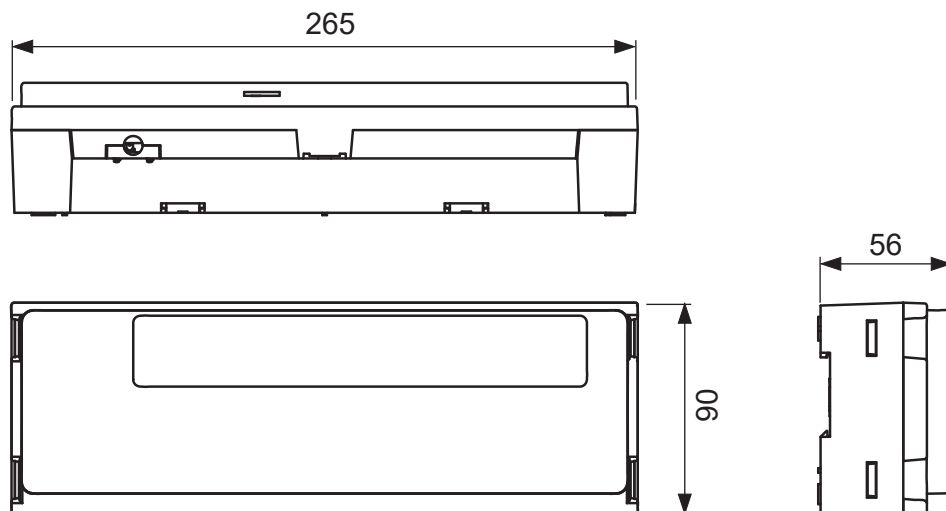

Peso: 820 g

8. DIRETTIVE

Designazione	Descrizione	Collegamento
Direttiva bassa tensione (LVD) 2014/35/EU	La Direttiva bassa tensione (LVD) (2014/35/UE) assicura che entro determinati limiti di tensione le apparecchiature elettriche prevedano un livello elevato di protezione per i cittadini europei e sfrutta appieno i vantaggi del mercato unico europeo.	2014/35/EU
Compatibilità elettromagnetica (EMC) Direttiva 2014/30/EU	La Direttiva compatibilità elettromagnetica (EMC) 2014/30/UE assicura che le apparecchiature elettriche ed elettroniche non generino o subiscano interferenze elettromagnetiche.	2014/30/EU
Direttiva RoHS 2011/65/EU sulla restrizione all'uso di determinate sostanze pericolose	Direttiva sulla restrizione all'uso di determinate sostanze pericolose nelle apparecchiature elettriche ed elettroniche.	2011/65/EU
Direttiva RAEE sui rifiuti di apparecchiature elettriche ed elettroniche	La Direttiva RAEE (2012/19/UE) mira a ridurre la quantità di rifiuti di apparecchiature elettriche ed elettroniche conferite in discarica.	2012/19/EU
Regolamento (EU) 2015/1188 della Commissione	Specifiche per la progettazione ecocompatibile degli apparecchi per il riscaldamento d'ambiente locale.	2015/1188
Direttiva apparecchiature radio (RED) 2014/53/EU	La Direttiva relativa alle apparecchiature radio 2014/53/ UE (RED) stabilisce un quadro normativo concernente la messa a disposizione delle apparecchiature radio sul mercato.	2014/53/EU

Inhoud

1.	ALGEMENE INFORMATIE	44
1.1	Veiligheidswaarschuwingen en gebruiksaanwijzingen	44
1.2	Toepassing	44
2.	PRESENTATIE	44
2.1	Eigenschappen	44
2.2	Inhoud van de verpakking	45
2.3	Eerste installatie	45
3.	PRODUCTOMSCHRIJVING	45
3.1	LED-kleuren betekenis	45
3.2	Druckknop	46
3.3	DIP-schakelaarconfiguratie	46
4.	INGANGEN/UITGANGEN	46
4.1	Voeding	46
4.2	Ingang verwarming/koeling	46
4.3	Pompuitgangen	47
4.4	Ingang voor vochtigheidsdetectie	47
4.5	Uitgang ontvochtiger	47
4.6	Verwarmings- en koeluitgangen	48
4.7	Externe antenne	48
5.	SYSTEEMCONFIGURATIE	48
6.	PROBLEMEN OPLOSSEN	49
7.	TECHNISCHE KENMERKEN	49
7.1	Technische gegevens	49
7.2	Afmetingen en gewicht	50
8.	RICHTLIJNEN	50

1. ALGEMENE INFORMATIE

1.1 Veiligheidswaarschuwingen en gebruiksaanwijzingen

Dit product dient bij voorkeur door een gekwalificeerde vakman te worden geïnstalleerd. Met inachtneming van de bovenstaande bepalingen neemt de fabrikant de aansprakelijkheid voor de apparatuur op zich zoals voorzien in de wettelijke bepalingen. Alle instructies in deze installatie- en bedieningshandleiding moeten in acht worden genomen bij het werken met de regelaar. Storingen door verkeerde installatie, verkeerd gebruik of slecht onderhoud maken de aansprakelijkheid van de fabrikant ongedaan.



Bij elke poging tot reparatie vervalt de verantwoordelijkheid en de verplichting tot garantie en vervanging door de fabrikant. 2012/19/EU (WEEE-richtlijn): Producten met dit symbool mogen in de Europese Unie niet als ongesorteerd huishoudelijk afval worden afgevoerd. Voor correcte recycling dient u dit product bij aankoop van gelijkwaardige nieuwe apparatuur in te leveren bij uw plaatselijke leverancier, of af te geven bij aangewezen inzamelpunten. Zie voor meer informatie: www.recyclethis.info

1.2 Toepassing

De regelaar is ontworpen voor gebruik in woonruimten, kantoorruimten en industriële installaties. Controleer vóór gebruik of de installatie voldoet aan de bestaande voorschriften om een juist gebruik van de installatie te waarborgen.

2. PRESENTATIE

De SH-HCM is speciaal ontworpen om verwarming en koeling te regelen in combinatie met SH-CD-regelaars. De beoogde toepassing is dus 2 leidingen met meerdere zones watervloerverwarming en -koeling. Dit apparaat is een optie en er is slechts één module per installatie mogelijk. Het moet in de buurt van de verwarmings- en koelingsbron (warmtepomp) worden geïnstalleerd, terwijl de SH-CD-regelaars in de buurt van de verdeelstukken moeten worden geïnstalleerd. Het apparaat is een unit met 3 functionaliteiten:

- Apart verwarmings- en koelsignaal
- Ontvochtigingscontrole van de gehele installatie
- Verwarming en koeling aansturing van de gehele installatie

2.1 Eigenschappen

Het heeft meerdere functies geïntegreerd:

- Wandmontage of montage op DIN-rail
- Push-fit kabelverbindingen met trekontlasting
- LED-statusindicatie en DIP-schakelaar voor apparaatinstelling
- H&C ingang (230 V en spanningsvrij signaal)
- Vochtigheidsingang (Volt vrij contact) of watertemperatuurmetering (Sonde niet meegeleverd) voor vochtigheidsdetectie
- Uitgang ontvochtiger
- Pomp- of keteluitgang (230 V en voltvrij signaal)
- Verwarmingsvermogen en koelvermogen
- Interne RF-antenne, optionele externe antenne

2.2 Inhoud van de verpakking

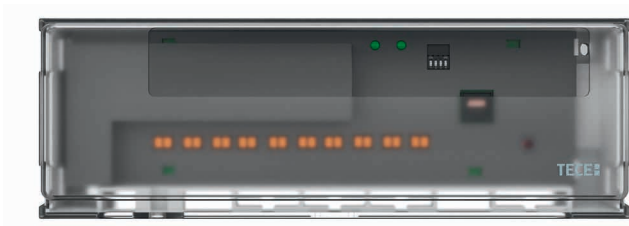

2.3 Eerste installatie

Er zijn 2 manieren om de controller te installeren

- Wandmontage met 2 schroeven.
- Gemonteerd op een DIN-rail

3. PRODUCTOMSCHRIJVING

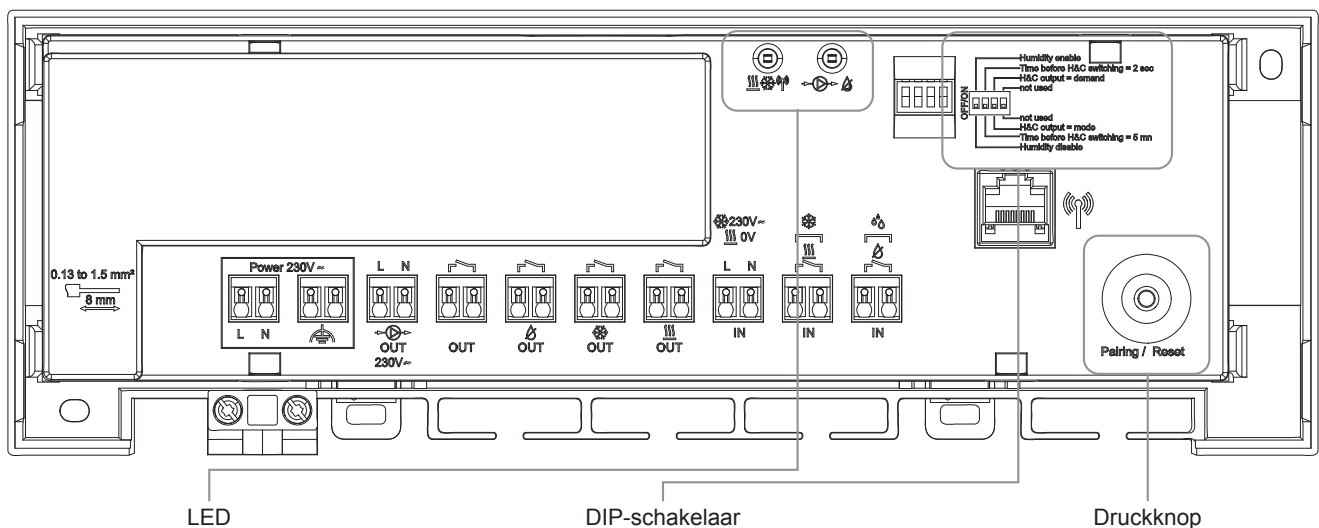

3.1 LED-kleuren betekenis

LED	Betekenis
Verwarmen en Koelen en RF LED (Rood/Blauw/Groen)	Fix Rood = Verwarmingsmodus
	Fix Blauw = Koelmodus
	Rood/Blauw knipperend = RF verlies (In geval van RF verlies, schakelt de SH-HCM in verwarmingsmodus en activeert de pomp).
Pomp/Vochtigheid/Fout LED (Rood/Blauw/Groen)	Groen knipperend = RF communicatie
	Rood knipperend = NTC-fout
	Blauw knipperend = Globale vochtigheidsdetectie (In dat geval wordt de ontvochtiger geactiveerd)
	Fix Groen = pomp wordt geactiveerd
	Groen/Blauw knipperend: Globale vochtigheidsdetectie en activering van de pomp
	Groen/Rood knipperend: Pomp wordt geactiveerd en NTC-fout
Rood/Blauw/Groen knipperend = Globale vochtigheidsdetectie en pompactivering en NTC-fout	

3.2 Drückknop

10 s indrukken activeert het koppelproces,
20 s drukken activeert de reset van het apparaat.

3.3 DIP-schakelaarconfiguratie

DIP-schakelaar	Functie	Waarde (standaard: UIT)	Configuratie	Beschrijving
DIP1	Vochtigheidsactivering	OFF	Schakel uit	Zie 4.4 en 4.5
		ON	Schakel in	
DIP2	H&C schakelaar	OFF	5 minuten	Zie 4.2
		ON	2 seconden	
DIP3	H&C uitgangsmodus	OFF	Modus	Zie 4.6
		ON	Vraag	
DIP4	Vochtigheidsinput	OFF	Vrije contactingang	Zie 4.4
		ON	NTC-sensor	

4. INGANGEN/UITGANGEN

4.1 Voeding

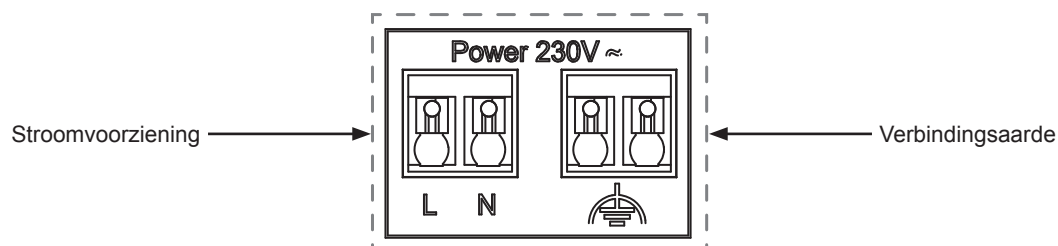

4.2 Ingang verwarming/koeling

Doel: Met deze ingang kan de regelmodus voor het systeem worden omgeschakeld: Verwarmen of koelen.

Bron van het signaal:

- Een mechanische schakelaar
- De warmtepomp
- Een SH-SM gekoppeld aan de SH-CU centrale als AAN/UIT apparaat. Deze oplossing maakt een afstandsbediening van de H&C-modus mogelijk.

Aard van het signaal: De ingang kan potentiaalvrij zijn of 230 V.

Modus	Vrij contact	Live contact
Verwarming	Geopend	Geen signaal.
Koeling	Gesloten	230 V AC

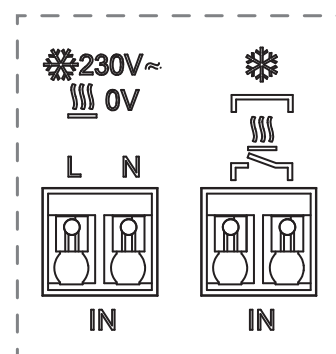

De H&C-modus wordt dan aan het hele systeem door gegeven.

Slechts één apparaat in het systeem mag de H&C-modus kunnen selecteren (Master H&C-apparaat).

Andere mogelijke H&C-schakelsignaalbronnen:

- SH-CU centrale
- H&C-ingang op SH-CD-regelaars
- Digitale thermostaat geconfigureerd als een Master H&C thermostaat in handmatige of automatische modus.

Met de DIP-schakelaar op de SH-CD-regelaar kan het apparaat worden geselecteerd dat verantwoordelijk is voor de H&C-modus (Master H&C-apparaat).

De tijd voor de H&C-schakelaar wordt bepaald door de DIP2 (zie 3.3):

- DIP2 = OFF: 5 minuten
- DIP2 = ON: 2 seconden

4.3 Pomputgangen

Er zijn 2 uitgangen:

- Uitgang onder spanning (230 V AC)
- Potentiaal vrije uitgang

Deze uitgangen kunnen worden gebruikt aan te sturen:

- Een zoneklep
- Een pomp
- Een ketel of warmtepomp

De 2 uitgangen worden geactiveerd wanneer er een verwarmings- of koelingsvraag is, die door de SH-CD regelaar naar de SH-HCM wordt gestuurd.

Het pompsignaal is altijd globaal, d.w.z. de pomp wordt geactiveerd wanneer er in het systeem vraag is naar verwarming of koeling. Bij een RF-storing wordt de pomp steeds geactiveerd.

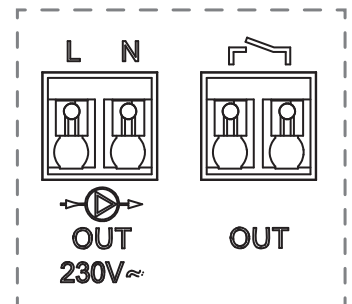

4.4 Ingang voor vochtigheidsdetectie

Wanneer DIP1= ON (Zie 3.3) beheert de module een vochtigheidsdetectie-ingang, met 2 mogelijke signaaltypes, afhankelijk van DIP4 (Zie 3.3):

- Watertemperatuursensor (NTC 10 kΩ): Vereist SH-DTH-thermostaat
- Een vochtigheidscontactsensor

Vochtighheidscontactsensor

Aard van het signaal: De ingang is een vrij contact

Geen vochtigheid	Geopend contact
Vochtigheid gedetecteerd	Gesloten contact

Wanneer de vochtigheid wordt gedetecteerd door de sensor, wordt de informatie verzonden naar de SH-CD-regelaar die de informatie beheert. Bovendien wordt de ontvochtigingsuitgang geactiveerd.

Watertemperatuursensor

De meting van de watertemperatuur wordt naar alle SH-CD-regelaars gestuurd om het dauwpunt te berekenen voor vochtigheidsregeling in de koelmodus (Raadpleeg de folder van de SH-CD).

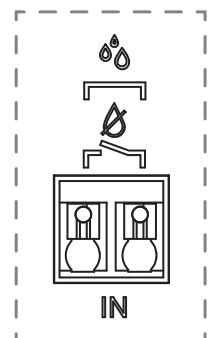

4.5 Uitgang ontvochtiger

Wanneer DIP1 = ON (Zie 3.3) wordt de ontvochtigingsuitgang (Vrij contact) in 2 gevallen geactiveerd:

- Wanneer de vochtigheidsingang wordt geactiveerd (Zie 4.4)
- Wanneer de SH-CD-regelaar de ontvochtiger opdracht geeft

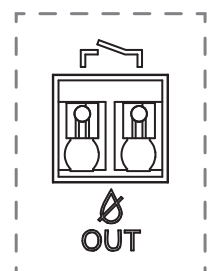

4.6 Verwarmings- en koeluitgangen

Het gedrag van de uitgangen (vrij contact) is afhankelijk van de DIP3 (zie 3.3):

- DIP3 = OFF: De verwarmings- of koeluitgang wordt constant geactiveerd volgens de modus van de installatie (verwarmen of koelen).
- DIP3 = ON: De verwarmings-/koelingsuitgang wordt geactiveerd wanneer er in de installatie vraag is naar verwarming of koeling.

Bij RF-storing wordt de verwarmingsuitgang continu geactiveerd.

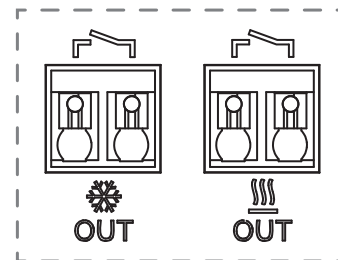

4.7 Externe antenne

De afstand tussen 2 apparaten met interne antenne moet minstens 50 cm bedragen.

De controller heeft een interne antenne. Indien nodig kan een externe antenne worden aangesloten om de RF-communicatie te verbeteren. Dit kan nuttig zijn als de controller in een metalen omkasting wordt geïnstalleerd. In dat geval moet u de externe antenne buiten de metalen omkasting installeren.

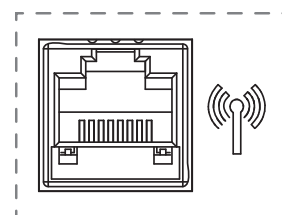

Respecteer het montage-advies om de gevoeligheid te optimaliseren en storingen te voorkomen.

De antenne moet geïnstalleerd zijn:

- buiten de metalen omkasting,
- in verticale positie
- en ten minste op 50 cm van metalen delen.

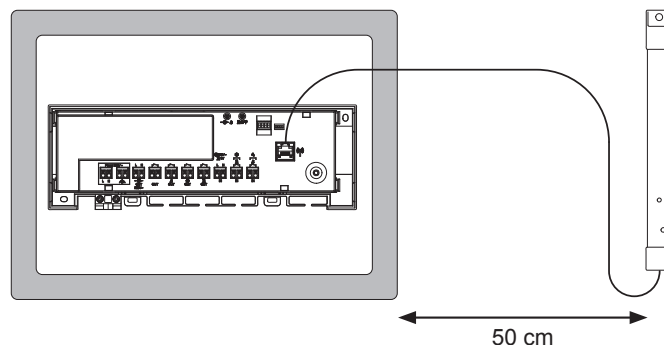

5. SYSTEEMCONFIGURATIE

De SH-HCM moet altijd worden gekoppeld aan een SH-CD-regelaar, zelfs als u een SH-CU gebruikt. Er is altijd maar één SH-HCM per installatie..

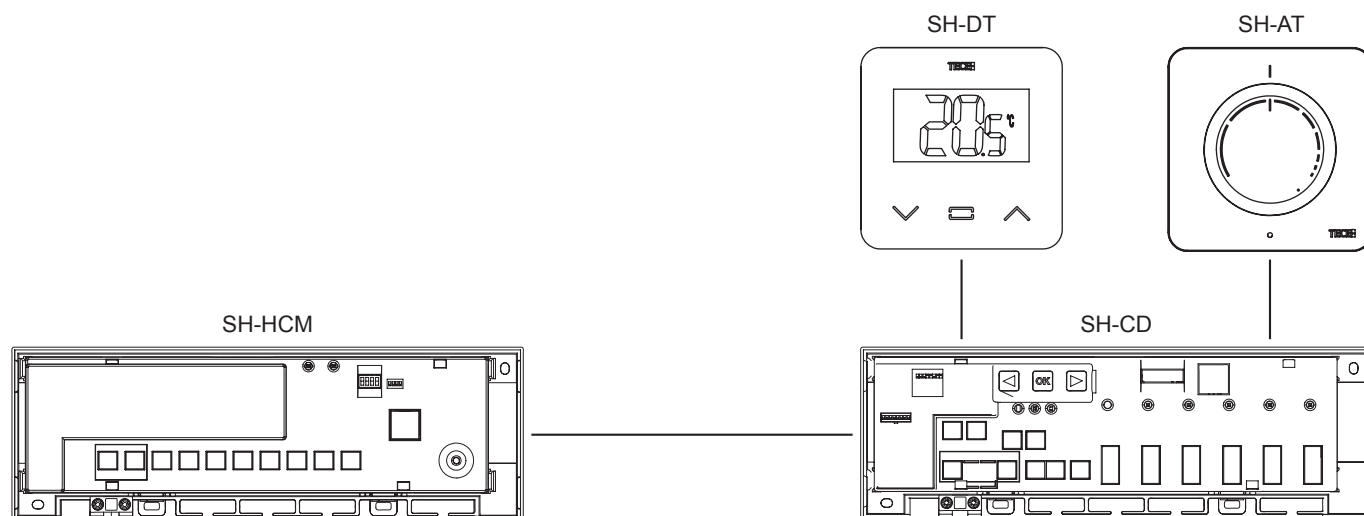

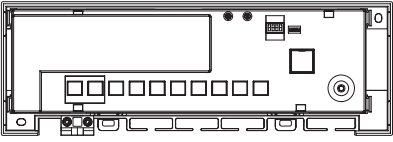
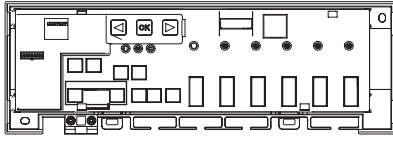
Apparaat 1: SH-HCM	Apparaat 2: SH-CD	Opmerkingen
 <p>Zet het apparaat in de RF-koppelingsmodus. Druk gedurende 10 seconden op de knop.</p>	 <p>Door gedurende 5 seconden op OK te drukken, gaat de regelaar naar het RF koppelingsmenu. Selecteer met ◀ of ▶ zone 3 (LED knippert rood), druk op OK om naar de modus Koppelen met een slaafapparaat te gaan. Alle LED's knipperen groen.</p>	<p>Wanneer de koppeling is voltooid, keert de SH-CD terug naar het menu voor RF-koppeling en keert de SH-HCM terug naar de normale modus.</p>

6. PROBLEMEN OPLOSSEN

Symptoom	Problemen	Beschrijving	Problemen oplossen
Rood/blauw knipperen van Verwarmen en Koelen en RF LED	RF kwestie	De SH-HCM heeft de verbinding met de SH-CD-controller verloren.	Controleer de afstand tussen de apparaten. Als het apparaat in een metalen omkasting is geïnstalleerd, gebruik dan een externe antenne buiten de metalen omkasting. Een externe antenne is ook nuttig bij een grote afstand tussen apparaten. Het gebruik van een externe antenne op de SH-CD en SH-HCM verbetert de RF-communicatie. Het gebruik van een repeater gekoppeld aan de SH-CD kan nodig zijn.
Rood knipperend van pomp/vochtigheids-LED	NTC-fout	Als DIP4 = ON, moet een watertemperatuursensor worden aangesloten op de vochtigheidsingang.	Controleer DIP4-instelling en NTC

7. TECHNISCHE KENMERKEN

7.1 Technische gegevens

	SH-HCM
Elektrische bescherming	Klasse II met functionele aarde
IP Bescherming	IP 30
Verzend- en opslagtem-peratuur	-10 °C bis 50 °C (14 °F bis 122 °F)
Stroomvoorziening	230 V AC ± 10 % 50 Hz
Maximale uitgangsbelaasting (5 uitgangen)	Relais: 5 A
Compatibiliteit	SH-CD6-24, SH-CD10-24, SH-CD6-230, SH-CD10-230

7.2 Afmetingen en gewicht

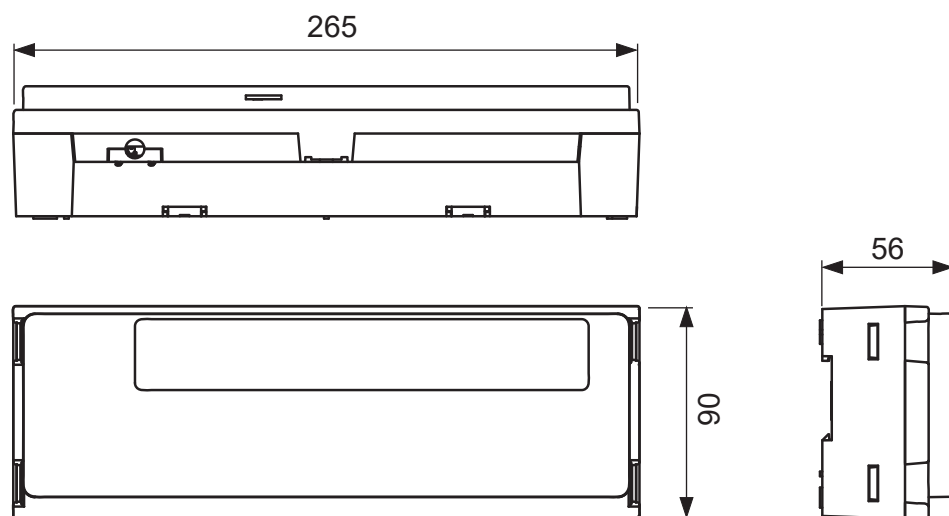

Gewicht: 820 g

8. RICHTLIJNEN

Aanwijzing	Beschrijving	Link
Laagspanningsrichtlijn (LVD)	De laagspanningsrichtlijn (LVD) (2014/35/EU) zorgt ervoor dat elektrisch materiaal binnen bepaalde spannings-grenzen een hoog beschermingsniveau biedt aan Europese burgers en volledig profiteert van de interne markt.	2014/35/UE
Elektromagnetische compatibiliteit (EMC) Richtlijn 2014/30/EU	De Richtlijn Elektromagnetische Compatibiliteit (EMC) 2014/30/EU zorgt ervoor dat elektrische en elektronische apparatuur geen elektromagnetische storingen veroorzaakt of er geen hinder van ondervindt.	2014/30/UE
Beperking van het gebruik van bepaalde richtlijn gevaarlijke stoffen (RoHS) 2011/65/EU	Richtlijn inzake de beperking van het gebruik van bepaalde gevaarlijke stoffen in elektrische en elektronische apparatuur.	2011/65/EU
Elektrisch afval & elektronische apparatuur Richtlijn (WEEE)	De AEEA-richtlijn (2012/19/EU) heeft tot doel de hoeveelheid afgedankte elektrische en elektronische apparatuur die op de stortplaats terecht komt, te verminderen.	2012/19/EU
Commissie ecologisch ontwerp Verordening	Eisen inzake ecologisch ontwerp voor lokale ruimteverwarmers.	2015/1188
Richtlijn radioapparatuur (RED) 2014/53/EU	De Richtlijn radioapparatuur 2014/53/EU (RED) stelt een regelgevingskader vast voor het op de markt brengen van radioapparatuur.	2014/53/EU

Rukerveiledning

1. GENERELL INFORMASJON	52
1.1 Sikkerhetsadvarsler og bruksanvisning	52
1.2 Søknad	52
2. PRESENTASJON	52
2.1 Funksjoner	52
2.2 Boksens innhold	53
2.3 Første installasjon	53
3. PRODUKTBESKRIVELSE	53
3.1 LED-fargemålinger	53
3.2 Trykknapp	54
3.3 DIP-bryterkonfigurasjon	54
4. INNGANGER/UTGANGER	54
4.1 Strømforsyning	54
4.2 Oppvarming/kjøling Inngang	54
4.3 Pumpeutgang	55
4.4 Inngang for deteksjon av luftfuktighet	55
4.5 Avfukterens effekt	55
4.6 Varme- og kjøleeffekt	56
4.7 Ekstern antenne	56
5. SYSTEMKONFIGURASJON	56
6. FEILSØKING	57
7. TEKNISKE EGENSKAPER	57
7.1 Dimensjoner og vekt	58
8. RETNINGSLINJER	58

1. GENERELL INFORMASJON

1.1 Sikkerhetsadvarsler og bruksanvisning

Dette produktet bør fortrinnsvis installeres av en kvalifisert fagperson. Under forutsetning av at vilkårene ovenfor overholdes, påtar produsenten seg ansvaret for utstyret i henhold til lovbestemmelsene.

Alle instruksjonene i denne installasjons- og bruksanvisningen må følges når du arbeider med regulatoren. Feil som skyldes feil installasjon, feil bruk eller dårlig vedlikehold, medfører at produsentens ansvar bortfaller.



Ethvert forsøk på reparasjon opphever produsentens ansvar og garanti- og erstatningsplikt. 2012/19/EU (WEEE-direktivet): Produkter merket med dette symbolet kan ikke kastes som usortert husholdningsavfall i EU. For riktig resirkulering må du returnere dette produktet til din lokale leverandør når du kjøper tilsvarende nytt utstyr, eller levere det til et angitt innsamlingssted. For mer informasjon, se: www.recyclethis.info

1.2 Søknad

Regulatoren er konstruert for bruk i boliger, kontorlokaler og industrianlegg. Kontroller at installasjonen er i samsvar med gjeldende forskrifter før du tar den i bruk for å sikre at den brukes på riktig måte.

2. PRESENTASJON

SH-HCM er spesielt utviklet for styring av varme og kjøling i kombinasjon med SH-CD-regulatorer. Bruksområdet er derfor gulvvarme og -kjøling med 2 rør og flere soner. Denne enheten er et tillegg, og det er bare mulig å installere én modul per installasjon. Den bør installeres i nærheten av varme- og kjølekilden (varmepumpe), mens SH-CD6-regulatorene bør installeres i nærheten av fordelerrørene. Enheten er et tillegg med 3 hovedverdiforslag:

- Separat varme- og kjølesignal
- Global styring av avfukter
- Global styring av varme- og kjølemodus

2.1 Funksjoner

Den har flere integrerte funksjoner:

- Veggmontert eller montert på DIN-skinne
- Push-in-kabeltilkoblinger med strekkavlastning
- LED-statusindikering og DIP-bryter for innstilling av enheten
- H&C-inngang (230 V og spenningsfritt signal)
- Fuktighetsinngang (voltfri kontakt) eller vanntemperaturmåling (sonde medfølger ikke) for deteksjon av fuktighet
- Avfukterens effekt
- Pumpe- eller kjeleutgang (230 V og spenningsfritt signal)
- Oppvarmingseffekt og kjøleeffekt
- Intern RF-antenne, valgfri ekstern antenne

2.2 Boksens innhold

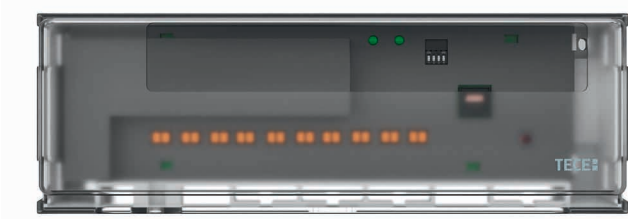

2.3 Første installasjon

Det er to måter å installere kontrolleren på

- Veggmontert med 2 skruer.
- Monteres på en DIN-skinne

3. PRODUKTBEKRIVELSE

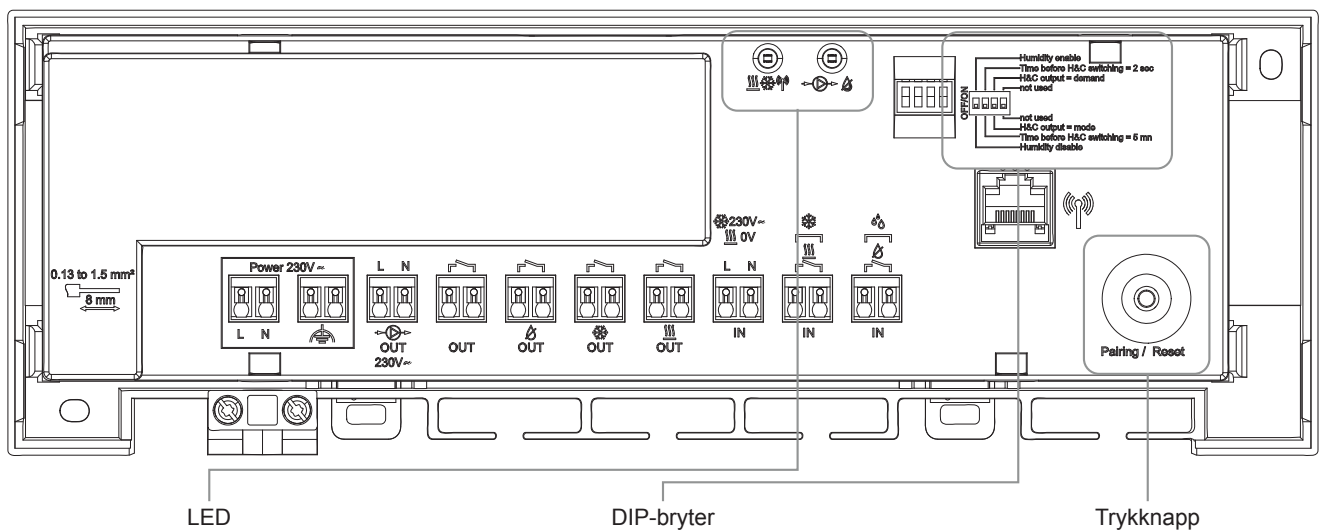

3.1 LED-fargemålinger

LED	Bedeutung	
Varme- og kjøle- og RF-LED (rød/blå/grønn)	Fikse rød =	Oppvarmingsmodus
	Fikse blå =	Kjølemodus
	Blinker rødt/blått =	RF-tap (ved RF-tap skifter SH-HCM til oppvarmingsmodus og utløser pumpen).
	Grønt blinkende =	RF-kommunikasjon
LED for pumpe/fuktighet/feil (rød/blå/grønn)	Blinker rødt =	NTC-feil
	Blått blinkende =	Global fuktighetsregistrering (i dette tilfellet utløses avfukteren).
	Fikser grønn =	Pumpen er utløst
	Grønt/blått blinkende =	Global fuktighetsregistrering og aktivering av pumpe
	Grønt/rødt blinkende =	Pumpen er utløst og NTC-feil
	Blinkende rødt/blått/grønt =	Global fuktighetsregistrering og aktivering av pumpe og NTC-feil

3.2 Trykknapp

10 s trykk utløser sammenkoblingsprosessen.
20 sekunders trykk utløser tilbakestilling av enheten.

3.3 DIP-bryterkonfigurasjon

Nummer på DIP-bryter	Funksjon	Verdi (standard: OFF)	Konfigurasjon	Beskrivelse
DIP1	Aktivering av fuktighet	OFF	Deaktivere	Se 4.4 og 4.5
		ON	Aktivere	
DIP2	H&C-bryter	OFF	5 minutter	Se 4.2
		ON	2 sekunder	
DIP3	H&C utgangsmodus	OFF	Modus	Se 4.6
		ON	Etterspørsel	
DIP4	Luftfuktighetsinngang	OFF	Fri kontaktinngang	Se 4.4
		ON	NTC-sensor	

4. INNGANGER/UTGANGER

4.1 Strømforsyning

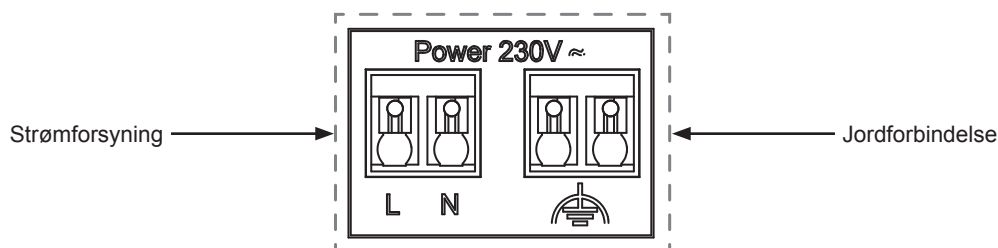

4.2 Oppvarming/kjøling Inngang

Formål: Denne inngangen gjør det mulig å bytte reguleringsmodus for systemet: Oppvarming eller kjøling.

Kilden til signalet:

- En mekanisk bryter.
- Varmepumpen.
- En SH-SM koblet til SH-CU-sentralenheten som en PÅ/AV-enhet. Denne løsningen gjør det mulig å fjernstyre H&C-modus fra applikasjonen.

Signalets format:

Inngangen kan være fri kontakt eller strømførende kontakt 230 V.

Modus	Gratis kontakt	Direkte kontakt
Oppvarming	Åpnet	Ikke noe signal
Kjøling	Stengt	230 V vekselstrøm

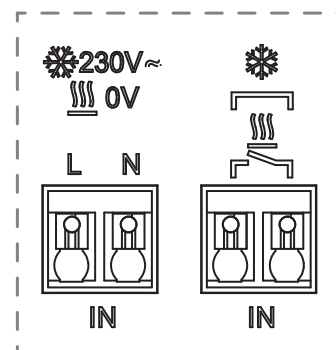

H&C-modusen forplanter seg deretter til hele systemet.

Bare én enhet i systemet skal kunne velge H&C-modus (Master H&C-enhet). Andre mulige H&C-bryter-signalkilder:

- SH-CU-sentralenhet.
- H & C-inngang på SH-CD-kontrollere.
- Digital termostat konfigurert som en Master H&C-termostat i manuell eller automatisk modus.

DIP-bryteren på SH-CD-kontrollerne gjør det mulig å velge hvilken enhet som er ansvarlig for H&C-modus (Master H&C-enhet).

Tiden før H&C-bryteren slås på defineres av DIP2 (se 3.3):

- DIP2 = OFF: 5 minutter
- DIP2 = ON: 2 sekunder

4.3 Pumpeutgang

Det er to utganger:

- Strømførende kontaktutgang (230 Vac).
- Utgang med fri kontakt.

Disse utgangene kan brukes til å trigge:

- En soneventil.
- En pumpe.
- Kjele eller varmpumpe.

De 2 utgangene utløses når det foreligger et varme- eller kjølebehov, som sendes fra SH-CD-regulatoren til SH-HCM.

Pumpesignalet er alltid globalt, dvs. at pumpen utløses når det er et varme- eller kjølebehov i systemet.

Hvis det oppstår en RF-feil, utløses pumpen hele tiden.

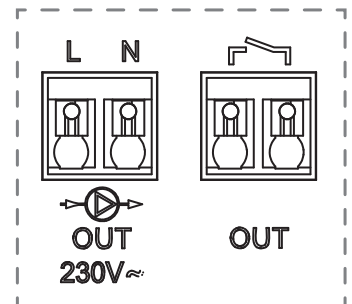

4.4 Inngang for deteksjon av luftfuktighet

Når DIP1= ON (se 3.3) håndterer produktet en fuktighetsdetekteringsinngang, med 2 mulige signaltyper avhengig av DIP4 (se 3.3):

- Sensor for vanntemperatur (NTC 10 kΩ): Krever SH-DTH-termostat.
- En kontaktsensor for fuktighet.

Kontaktsensor for fuktighet

Signalets format:

Inngangen er en fri kontakt.

Ingen fuktighet	Åpnet kontakt
Detektert fuktighet	Lukket kontakt

Når sensoren registrerer fuktighet, sendes informasjonen til SH-CD-kontrolleren som håndterer informasjonen. I tillegg utløses avfukterens utgang.

Sensor for vanntemperatur.

Vanntemperaturmålingen sendes til alle SH-CD-regulatorer for å beregne duggpunktet for fuktighetsregulering i kjølemodus (se brosjyren for SH-CD).

4.5 Avfukterens effekt

Når DIP1 = ON (se 3.3), utløses avfukterutgangen (fri kontakt) i 2 tilfeller:

- Når inngangen for luftfuktighet utløses (se 4.4).
- Når SH-CD-kontrolleren bestiller avfukteren.

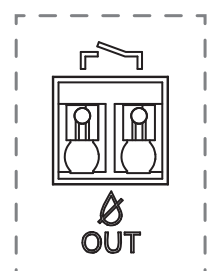
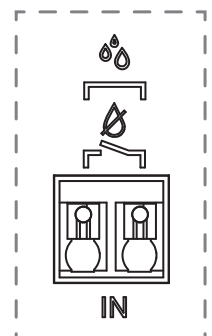

4.6 Varme- og kjøleeffekt

Oppførselen til utgangene (fri kontakt) er avhengig av DIP3 (Se 3.3):

- DIP3 = OFF: Varme- eller kjøleutgangen utløses konstant i henhold til installasjonsmodus (oppvarming eller kjøling).
- DIP3 = ON: Varme-/kjøleutgangen aktiveres når det er et varme- eller kjølebehov i installasjonen.

Ved RF-feil utløses varmeutgangen hele tiden.

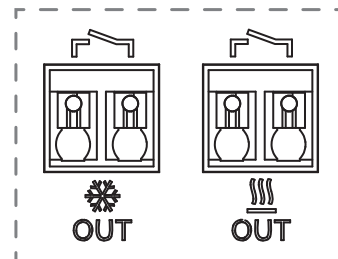

4.7 Ekstern antenne

Kontrolleren har en intern antenne. Ved behov kan en ekstern antenne kobles til for å forbedre RF-kommunikasjonen. Det kan være nyttig hvis styreenheten er installert inne i en metallboks. I så fall må du installere den eksterne antennen utenfor metallboksen.

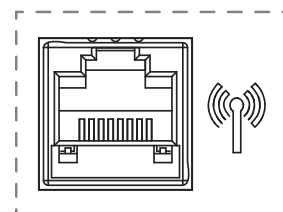

Respekter monteringen for å optimalisere følsomheten og unngå dysfunksjon.

Antenne må være installert:

- utenfor metallboksen
- i vertikal stilling
- og minst 50 cm fra metalliske deler

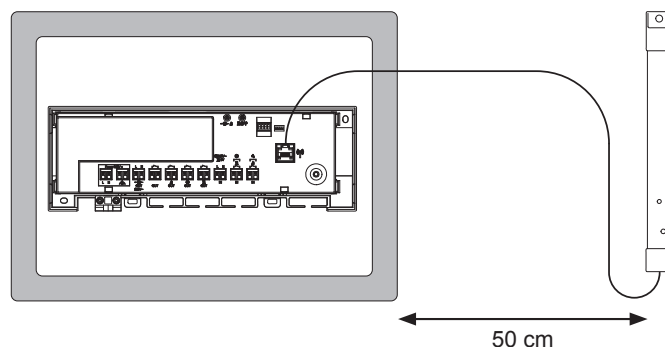

5. SYSTEMKONFIGURASJON

SH-HCM skal alltid pares med en SH-CD-kontroller, selv om du bruker en SH-CU. Det finnes alltid bare én SH-HCM per installasjon.

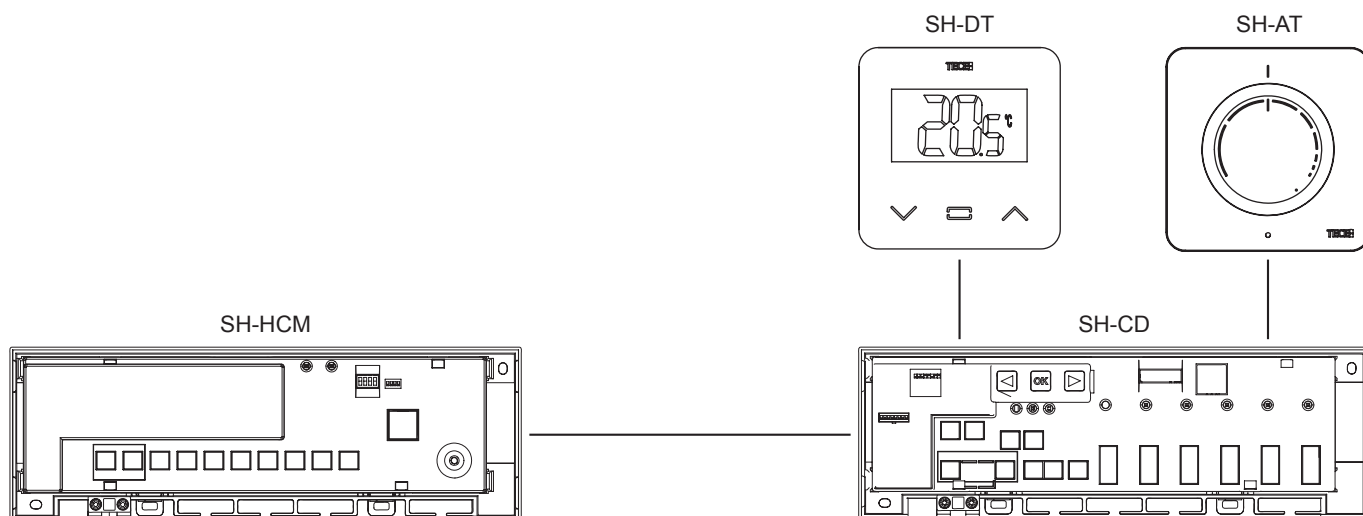

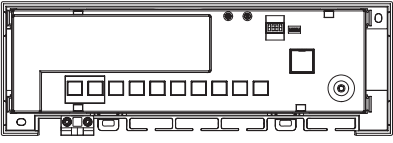
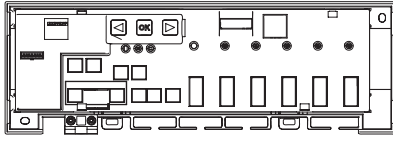
Enhet 1: SH-HCM	Enhet 2: SH-CD6-230	Merknader
 <p>Sett enheten i RF-koblingsmodus. Trykk på knappen i 10 sekunder.</p>	 <p>Ved å trykke på OK i 5 sekunder går kontrolleren til RF-paringsmenyen. Bruk ◀ eller ▶ til å velge sone 3 (LED-lampen blinker rødt), og trykk på OK for å gå inn i modus for sammenkobling med en slaveenhet. Alle lysdiodene blinker grønt.</p>	<p>Når koblingen er fullført, går SH-CD tilbake til RF-paringsmenyen og SH-HCM går tilbake til normal modus.</p>

6. FEILSØKING

Symptom	Problemer	Beskrivelse	Feilsøking
Rød/blå blinking på varme- og kjøle- og RF-LED-lampen	RF-problem	SH-HCM har mistet forbindelsen med SH-CD-kontrolleren.	Kontroller avstanden mellom enhetene. Hvis enheten er installert i en metallboks, kan du bruke en ekstern antenne som er plassert utenfor metallboksen. Ekstern antenne er også nyttig ved lang avstand mellom enhetene. Bruk av en ekstern antenne på SH-CD og SH-HCM forbedrer RF-kommunikasjonen. Det kan være nødvendig å bruke en repeater sammenkoblet med SH-CD.
Rød blinking på LED for pumpe/fuktighet	NTC-feil	Hvis DIP4 = ON, bør en vanntempertursensor kobles til fuktighetsinngangen.	Kontroller DIP4-innstillingen og NTC.

7. TEKNISKE EGENSKAPER

	SH-HCM
Elektrisk beskyttelse	Klasse II med funksjonell jord
IP-beskyttelse	IP30
Transport- og lagringstemperatur	-10 °C til 50 °C (14 °F til 122 °F)
Strømforsyning	230 Vac ± 10 % 50 Hz
Maksimal utgangsbelastning (5 utganger)	Relé: 5 A
Kompatibilitet	SH-CD6-24, SH-CD10-24, SH-CD6-230, SH-CD10-230

7.1 Dimensjoner og vekt

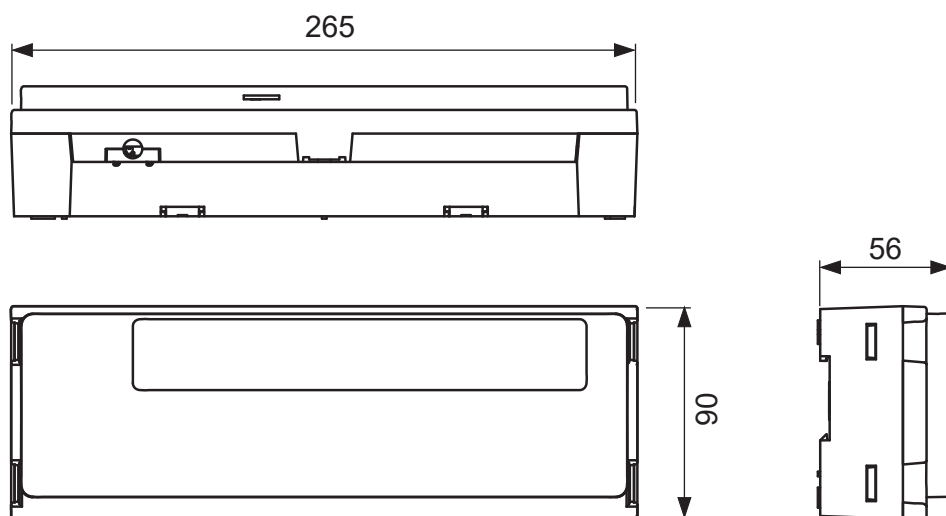

Vekt: 820 g

8. RETNINGSLINJER

Bezeichnung	Beschreibung	Link
Lavspenningsdirektivet (LVD)	Lavspenningsdirektivet (LVD) (2014/35/EU) sikrer at elektrisk utstyr innenfor visse spenningsgrenser gir et høyt beskyttelsesnivå for europeiske borgere, og at de får full nytte av det indre markedet.	2014/35/UE
Elektromagnetisk kompatibilitet (EMC) Direktiv 2014/30/EU	Direktivet om elektromagnetisk kompatibilitet (EMC) 2014/30/EU sikrer at elektrisk og elektronisk utstyr ikke genererer eller påvirkes av elektromagnetiske forstyrrelser.	2014/30/UE
Begrensning av bruken av visse direktivet om farlige stoffer (RoHS) 2011/65/ EU	Direktiv om begrensning av bruken av visse stoffer og farlige stoffer i elektrisk og elektronisk utstyr.	2011/65/EU
Elektrisk avfall & Elektronisk utstyr Direktiv (WEEE)	WEEE-direktivet (2012/19/EU) har som mål å redusere mengden elektrisk og elektronisk avfall som havner på deponi.	2012/19/EU
Kommisjonen for økodesign Regulering	Økodesignkrav for lokale romoppvarmere.	2015/1188
Direktiv 2014/53/EU om radioutstyr (RED)	Radioutstyrsdirektivet 2014/53/EU (RED) etablerer et regelverk for markedsføring av radioutstyr.	2014/53/EU

ANVÄNDARGUIDE

1.	ALLMÄN INFORMATION	60
1.1	Säkerhetsvarningar och bruksanvisningar	60
1.2	Tillämpning	60
2.	PRESENTATION	60
2.1	Funktioner	60
2.2	Boxens innehåll	61
2.3	Första installationen	61
3.	PRODUKTBESKRIVNING	61
3.1	LED-färgbeteckningar	61
3.2	Tryckknapp	62
3.3	Konfiguration av DIP-omkopplare (i orange)	62
4.	INGÅNGAR/UTGÅNGAR	62
4.1	Strömförsörjning	62
4.2	Värme/kyla Ingång	62
4.3	Pumputgång	63
4.4	Ingång för detektering av luftfuktighet	63
4.5	Avfuktarens effekt	63
4.6	Värme- och kyleffekt	64
4.7	Extern antenn	64
5.	SYSTEMKONFIGURATION	64
6.	FELSÖKNING	65
7.	TEKNISKA EGENSKAPER	65
7.1	Mått och vikt	66
8.	DIREKTIV	66

1. ALLMÄN INFORMATION

1.1 Säkerhetsvarningar och bruksanvisningar

Denna produkt bör installeras av en kvalificerad fackman. Under förutsättning att ovanstående villkor följs, åtar sig tillverkaren det ansvar för utrustningen som följer av lagstadgade bestämmelser.

Alla anvisningar i denna installations- och bruksanvisning ska följas när du arbetar med styrenheten. Fel som beror på felaktig installation, felaktig användning eller bristfälligt underhåll innebär att tillverkarens ansvar upphör att gälla.



Varje försök till reparation upphäver ansvaret och skyldigheten till garanti och ersättning från tillverkaren. 2012/19/EU (WEEE-direktivet): Produkter som är märkta med denna symbol får inte slängas som osorterat kommunalt avfall inom Europeiska unionen. För korrekt återvinning, returnera denna produkt till din lokala leverantör vid köp av motsvarande ny utrustning, eller kassera den på utsedda insamlingsställen. För mer information se: www.recyclethis.info Tillämpning

1.2 Tillämpning

Regulatorn är konstruerad för användning i bostäder, kontorslokaler och industrianläggningar. Kontrollera att installationen överensstämmer med gällande bestämmelser innan den tas i drift för att säkerställa att installationen används på rätt sätt.

2. PRESENTATION

SH-HCM är speciellt utformad för att reglera värme och kyla i kombination med SH-CD-regulatorer. Den avsedda applikationen är således 2-rörs flerzons vattenburen golvvärme och kylning. Denna enhet är ett tillval och endast en modul är möjlig per installation. Den bör installeras nära värme- och kylkällan (värmepumpen) medan SH-CD6-regulatorerna bör installeras nära fördelarna. Enheten är ett tillval med 3 huvudsakliga värdeförslag:

- Separat värme- och kylsignal
- Global styrning av avfuktare
- Global styrning av värme- och kylläge

2.1 Funktioner

Den har integrerat flera funktioner:

- Väggh monterad eller monterad på DIN-skene
- Push-in kabelanslutningar med dragavlastning
- ED-statusindikering och DIP-omkopplare för enhetsinställning
- H&C ingång (230 V och voltfri signal)
- Fuktighetsingång (voltfri kontakt) eller vattentemperaturmätning (sond medföljer ej) för fuktighetsdetektering
- Avfuktarens effekt
- Pump- eller pannutgång (230 V och spänningsfri signal)
- Värmeeffekt och kyleffekt
- Intern RF-antenn, extern antenn som tillval

2.2 Boxens innehåll

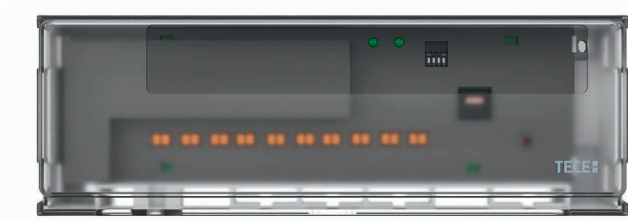

2.3 Första installationen

Det finns 2 sätt att installera styrenheten

- Vägghontering med 2 skruvar.
- Monterad på en DIN-skena

3. PRODUKTBESKRIVNING

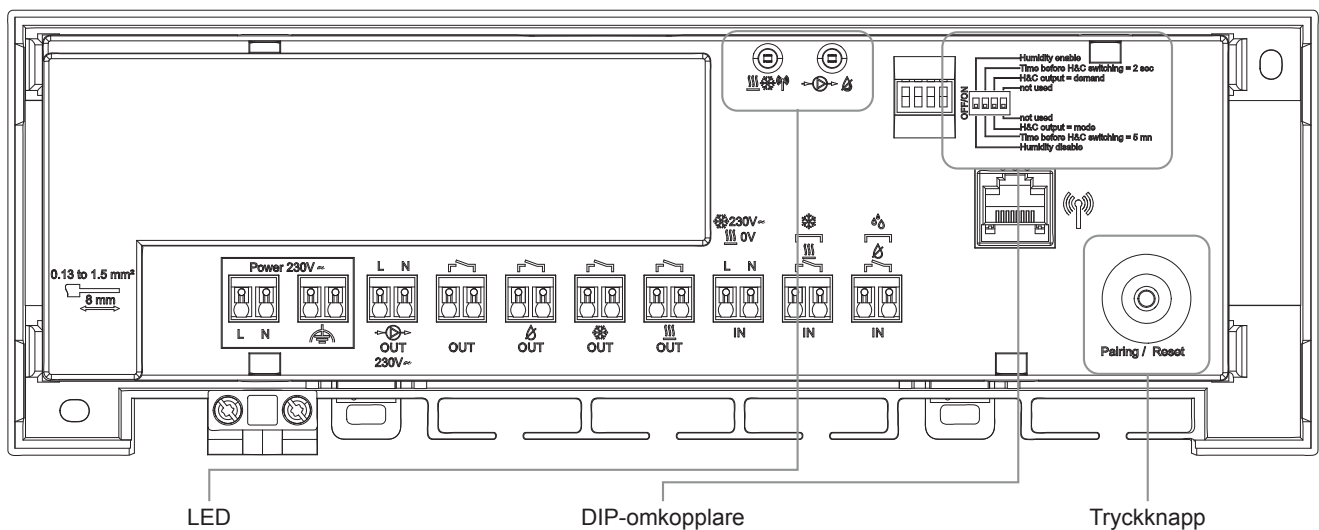

3.1 LED-färgbeteckningar

LED	Betydelse
Värme och kyla och RF LED (röd/blå/grön)	<p>Fix Röd = Uppvärmningsläge</p> <p>Fix Blå = Kylningsläge</p> <p>Röd / Blå blinkning = RF-förlust RF-förlust (Vid RF-förlust växlar SH-HCM till uppvärmningsläge och aktiverar pumpen)</p> <p>Grön blinkning = RF-kommunikation</p>
LED Pumpe/Entfeuchter/Fehler (Rot/Blau/Grün)	<p>Röd blinkande = NTC-fel</p> <p>Blått blinkande = Global fuktighetsdetektering (i detta fall aktiveras avfuktaren)</p> <p>Fixera grön = Pumpen är utlöst</p> <p>Grönt/blått blinkande = Global fuktighetsdetektering och pumpaktivering</p> <p>Grönt/rött blinkande = Pumpen är utlöst och NTC-fel</p> <p>Röd/blå/grön blinkande = Global fuktetktering och pumpaktivering samt NTC-fel</p>

3.2 Tryckknapp

10 s tryck utlöser parningsprocessen.
20 s tryck utlöser återställning av enheten.

3.3 Konfiguration av DIP-omkopplare (i orange)

Nummer på DIP-omkopplare	Funktion	Värde (standard: OFF)	Konfiguration	Beskrivning
DIP1	Aktivering av luftfuktighet	OFF	Inaktivera	se 4.4 och 4.5
		ON	Aktivera	
DIP2	H&C växling	OFF	5 minuter	se 4.2
		ON	2 sekunder	
DIP3	Utgångsläge för H&C	OFF	Läge	se 4.6
		ON	Efterfrågan	
DIP4	Ingång för luftfuktighet	OFF	Fri kontaktingång	se 4.4
		ON	NTC-sensor	

4. INGÅNGAR/UTGÅNGAR

4.1 Strömförsörjning

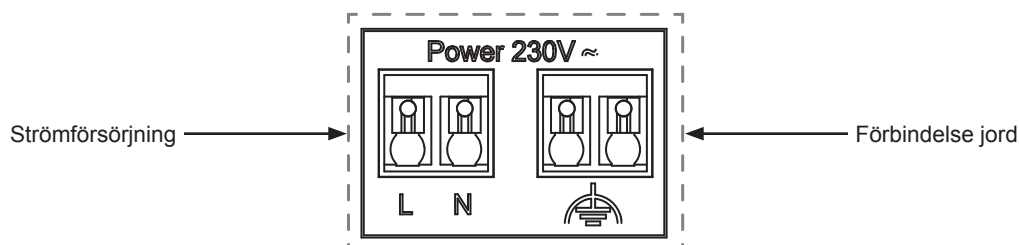

4.2 Värme/kyla Ingång

Syfte: Denna ingång gör det möjligt att växla regleringsläge för systemet: Värme eller kyla.

Signalens källa:

- En mekanisk brytare.
- Värmepumpen.
- En SH-SM kopplas till SH-CU-centralenheten som en ON/OFF-enhet. Denna lösning gör det möjligt att fjärrstyra H&C-läget från applikationen.

Signalens format: Inmatningen kan vara fri kontakt eller spänningssatt kontakt 230 V.

Läge	Fri kontakt	Direktkontakt
Uppvärmning	Öppnad	Ingen signal
Kylning	Stängt	230 Vac

H&C-läget sprids sedan över hela systemet.

Endast en enhet i systemet ska kunna välja HLK-läge (Master HLK-enhet). Andra möjliga signalkällor för H&C-omkopplare:

- SH-CU centralenhet.
- H&C synpunkter på SH-CD-kontroller.
- Digital termostat konfigurerad som en Master H&C-termostat i manuellt eller automatiskt läge.

DIP-omkopplaren på SH-CD-regulatorer gör det möjligt att välja vilken enhet som ska ansvara för H&C-läget (Master H&C-enhet).

Tiden innan H&C bryts definieras av DIP2 (se 3.3):

- DIP2 = OFF: 5 minuter
- DIP2 = ON: 2 sekunder

4.3 Pumputgång

Det finns 2 utgångar:

- Utgång för strömförande kontakt (230 Vac).
- Utgång med fri kontakt.

Dessa utgångar kan användas för att trigga:

- En zonventil.
- En pump.
- En värmepanna eller värmepump.

De 2 utgångarna aktiveras när det finns ett värme- eller kylbehov, som skickas av SH-CD-regulatorn till SH-HCM. Pumpsignalen är alltid global, dvs. pumpen aktiveras när det finns ett värme- eller kylbehov i systemet.

Om ett RF-fel inträffar aktiveras pumpen hela tiden.

4.4 Ingång för detektering av luftfuktighet

När DIP1= ON (se 3.3) hanterar produkten en ingång för fuktdetektering, med 2 möjliga signaltyper beroende på DIP4 (se 3.3):

- Vattentempersensur (NTC 10 k Ω): Krav på SH-DTH-termostat.
- En kontaktgivare för fuktighet.

Kontaktgivare för luftfuktighet

Signalens format: Inmatningen är en fri kontakt.

Ingen luftfuktighet	Öppnad kontakt
Luftfuktighet detekterad	Sluten kontakt

När fukt detekteras av sensorn skickas informationen till SH-CD-styrenheten som hanterar informationen. Dessutom aktiveras avfuktarens utgång.

Sensor för vattentemperatur.

Vattentemperaturmätningen skickas till alla SH-CD-regulatorer för att beräkna daggpunkten för fuktreglering i kyläge (se broschyren för SH-CD)

4.5 Avfuktarens effekt

När DIP1 = ON (se 3.3), aktiveras avfuktarens utgång (Fri kontakt) i 2 fall:

- När ingången för luftfuktighet aktiveras (se 4.4).
- När SH-CD-regulatorn beställer avfuktaren.

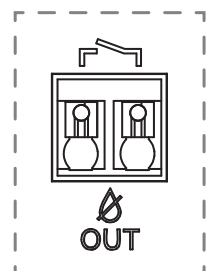
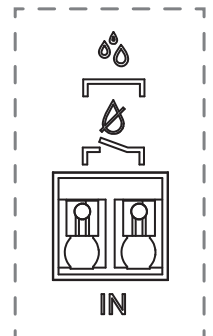

4.6 Värme- och kyleffekt

Utgångarnas beteende (fri kontakt) är beroende av DIP3 (se 3.3):

- DIP3 = OFF: Utgången för värme eller kyla aktiveras konstant i enlighet med installationens läge (värme eller kyla).
- DIP3 = ON: Utgången för värme/kyla aktiveras när det finns ett värme- eller kylbehov i installationen.

I händelse av RF-fel aktiveras värmeutgången hela tiden.

4.7 Extern antenn

Avståndet mellan 2 enheter med intern antenn bör vara minst 50 cm.

Styrenheten har en inbyggd antenn. Vid behov kan en extern antenn anslutas för att förbättra RF-kommunikationen. Det kan vara användbart om styrenheten är installerad i en metallbox. I så fall måste du installera den externa antennen utanför metallboxen.

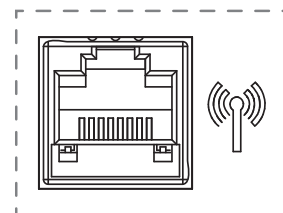

Vänligen respektera monteringen för att optimera känsligheten och undvika dysfunktion

Antenn måste vara installerad:

- utanför den metalliska boxen
- i vertikalt läge
- och minst 50 cm metalldelar

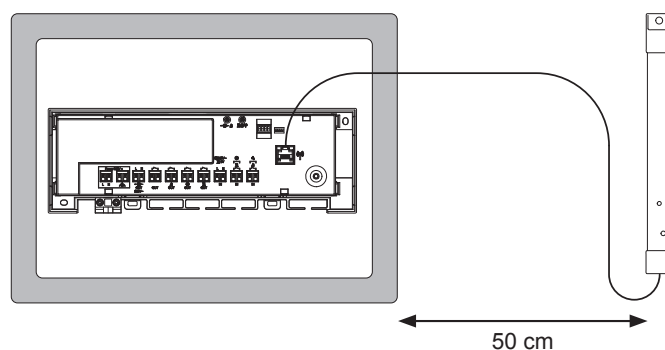

5. SYSTEMKONFIGURATION

SH-HCM ska alltid paras ihop med en SH-CD-regulator, även om du använder en SH-CU. Det finns alltid bara en SH-HCM per installation.

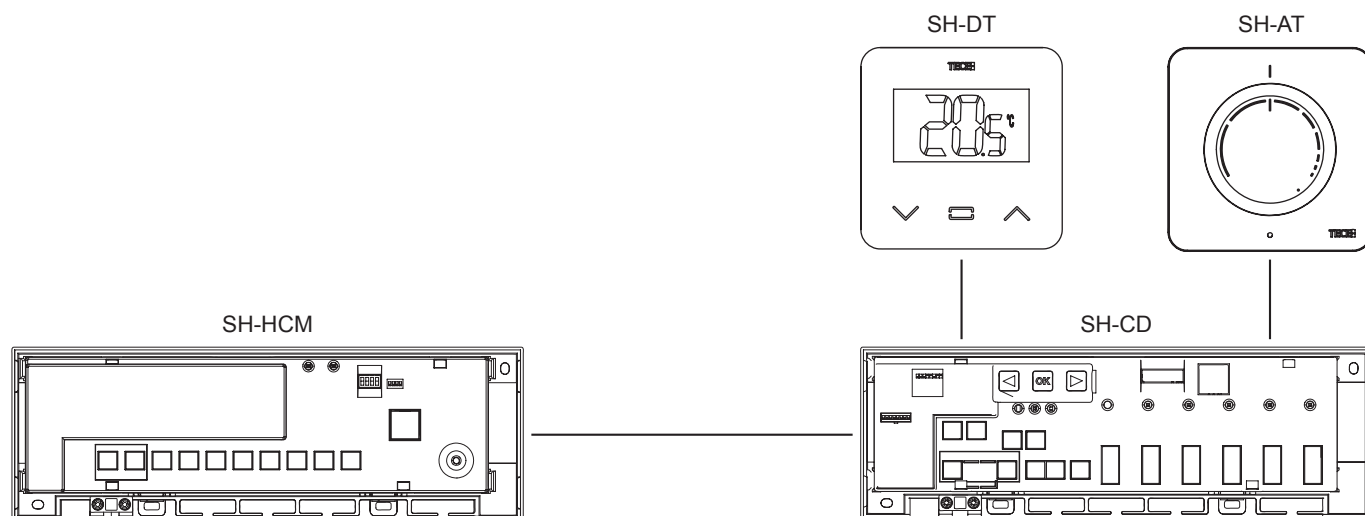

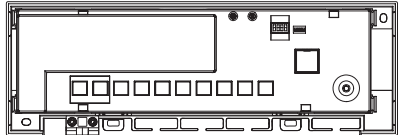
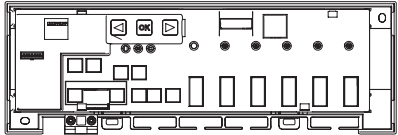
Enhet 1: SH-HCM	Enhet 2: SH-CD6-230	Anmärkingar
 <p>Ställ in enheten på RF-kopplingsläge. Tryck på knappen i 10 sekunder.</p>	 <p>Genom att trycka på OK i 5 sekunder går styrenheten till RF-parningsmenyn.</p> <p>Välj zon 3 med ◀ eller ▶ (LED:n blinkar rött), tryck på OK för att gå till läget Para ihop med en slavenhet.</p> <p>Alla lysdioder blinkar grönt.</p>	<p>När länken är klar återgår SH-CD till RF-parningsmenyn och SH-HCM återgår till normalläge.</p>

6. FELSÖKNING

Symptom	Problem	Beskrivning	Felsökning
Röd/blå blinkning på Värme och kyla och RF LED	RF-frågan	SH-HCM har förlorat anslutningen till SH-CD-regulatorn.	Kontrollera avståndet mellan enheterna. Om enheten är installerad i en metallbox, använd en extern antenn som är placerad utanför metallboxen. Extern antenn är också användbar för långa avstånd mellan enheter. Användning av en extern antenn på SH-CD och SH-HCM förbättrar RF-kommunikationen. Användning av en repeater kopplad till SH-CD kan krävas.
Röd blinkning på Pump/ Fuktighet LED	NTC-fel	Om DIP4 = ON ska en vattentemperaturgivare anslutas till ingången Humidity.	Kontrollera DIP4-inställningen och NTC.

7. TEKNISKA EGENSKAPER

	SH-HCM
Elektriskt skydd	Klass II med funktionell jord
IP-skydd	IP30
Transport- och lagringstemperatur	-10 °C till 50 °C (14 °F till 122 °F)
Strömförsörjning	230 Vac ± 10% 50 Hz
Utgångens maximala belastning (5 utgångar)	Relä: 5 A
Kompatibilitet	SH-CD6-24, SH-CD10-24, SH-CD6-230, SH-CD10-230

7.1 Mått och vikt

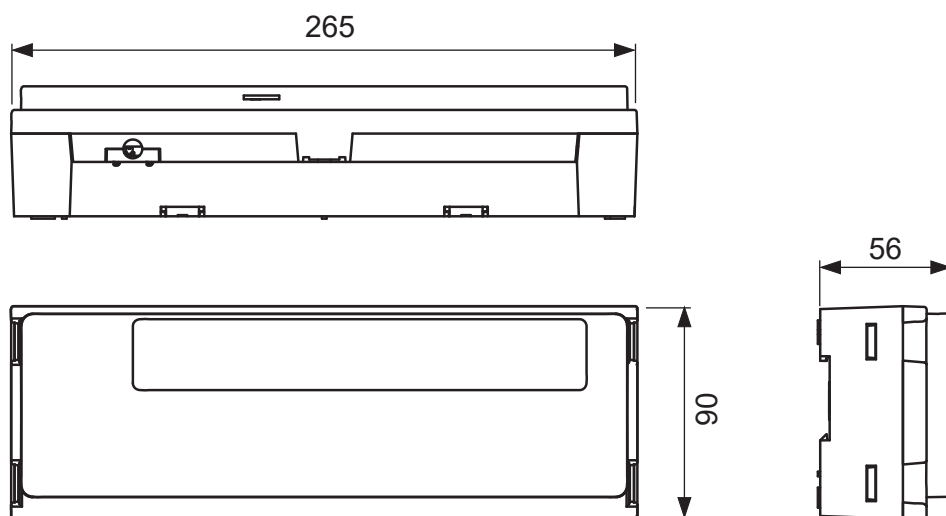

Vikt: 820 g

8. DIREKTIV

Beteckning	Beskrivning	Länk
Lågspänningsdirektivet (LVD)	Lågspänningsdirektivet (LVD) (2014/35/EU) säkerställer att elektrisk utrustning inom vissa spänningsgränser ger en hög skyddsnivå för europeiska medborgare, och drar full nytta av den inre marknaden.	2014/35/UE
Elektromagnetisk kompatibilitet (EMC) Direktiv 2014/30/EU	Direktivet om elektromagnetisk kompatibilitet (EMC) 2014/30/EU säkerställer att elektrisk och elektronisk utrustning inte genererar, eller påverkas av, elektromagnetisk störning.	2014/30/UE
Begränsning av användningen av vissa direktivet om farliga ämnen (RoHS) 2011/65/EU	Direktiv om begränsning av användningen av vissa farliga ämnen i elektriska och elektroniska utrustning.	2011/65/EU
Elektriskt avfall & Elektronisk utrustning Direktiv (WEEE)	WEEE-direktivet (2012/19/EU) syftar till att minska mängden avfall från elektrisk och elektronisk utrustning som hamnar på deponi.	2012/19/EU
Kommissionen för ekodesign Förordning	Ekodesignkrav för rumsvärmare.	2015/1188
Direktiv om radioutrustning (RED) 2014/53/EU	I radioutrustningsdirektivet 2014/53/EU (RED) fastställs ett regelverk för utsläppande av radio-utrustning på marknaden.	2014/53/EU

Sadržaj

1. OPĆE INFORMACIJE	68
1.1 Sigurnosne upute i upute za rad	68
1.2 Primjena	68
2. PREZENTACIJA	68
2.1 funkcije	68
2.2 sadržaj kutije	69
2.3 Prva instalacija	69
3. IDENTIFIKACIJA PROIZVODA	69
3.1 Značenja LED boja (crveno)	69
3.2 Gumb (zeleno)	70
3.3 Konfiguracija DIP prekidača (narančasto)	70
4. ULAZI/IZLAZI	70
4.1 napajanje	70
4.2 prelazeći zemlju	70
4.3 performanse pumpe	71
4.4 Ulaz za detekciju vlažnosti	71
4.5 Izlaz odvlaživača	71
4.6 snage grijanja i hlađenja	72
4.7 Vanjska antena	72
5. SISTEMSKA KONFIGURACIJA	72
6. RJEŠAVANJE PROBLEMA	73
7. TEHNIČKE KARAKTERISTIKE	73
7.1 Tehnički podaci	73
8. Težina	74

1. OPĆE INFORMACIJE

1.1 Sigurnosne upute i upute za rad

Poželjno je da ovaj proizvod instalira kvalificirani stručnjak. Uz poštivanje gore navedenih uvjeta, proizvođač prihvaća odgovornost za uređaj u okviru zakonskih odredbi. Prilikom rada s regulatorom potrebno je pridržavati se svih uputa u ovim uputama za montažu i rad. Pogreške uzrokovane nepravilnom instalacijom, nepravilnom uporabom ili nedostatkom održavanja poništavaju odgovornost proizvođača.



Svaki pokušaj popravka oslobađa vas odgovornosti i obveze jamstva i zamjene od strane proizvođača. 2012/19/EU (WEEE Direktiva): Proizvodi označeni ovim simbolom ne smiju se odlagati kao nerazvrstani komunalni otpad u Europskoj uniji. Za pravilno recikliranje, kada kupujete novi ekvivalentni proizvod, vratite ovaj proizvod svom lokalnom dobavljaču ili ga odložite na određenim sabirnim mjestima. Za više informacija pogledajte: www.stiftung-ear.de .Registracija

1.2 Primjena

Kontroler je dizajniran za korištenje u dnevnim sobama, uredima i industrijskim pogonima. Prije pokretanja provjerite je li instalacija u skladu s važećim propisima kako biste osigurali pravilnu upotrebu sustava.

2. PREZENTACIJA

SH-HCM posebno je razvijen za upravljanje grijanjem i hlađenjem u kombinaciji s SH-CD regulatorima . Ciljana primjena je stoga vodonosno površinsko grijanje i hlađenje kao 2-cijevni sustav. Ovaj uređaj je opcija i moguć je samo jedan modul po sustavu. Treba ga postaviti u blizini izvora grijanja i hlađenja (dizalica topline), dok regulatore SH-CD6C treba ugraditi u blizini razdjelnika. Uređaj je opcija s 3 glavne prednosti:

- Odvojeni signal grijanja i hlađenja
- Globalna kontrola odvlaživača
- Globalna kontrola rada grijanja i hlađenja

2.1 funkcije

Ima nekoliko integriranih funkcija:

- Montaža na zid ili montaža na DIN šinu
- Utični kabelski priključci s rasterećenjem napreznja
- LED prikaz statusa i DIP prekidači za podešavanje uređaja
- H&C ulaz (230 V i signal bez napona)
- Ulaz vlage (beznaponski kontakt) ili mjerenje temperature vode (sonda nije uključena) za detekciju vlažnosti
- rad odvlaživača
- Izlaz pumpe ili kotla (230 V i signal bez napona)
- kapacitet grijanja i kapacitet hlađenja
- Unutarnja RF antena, dodatna vanjska antena

2.2 sadržaj kutije

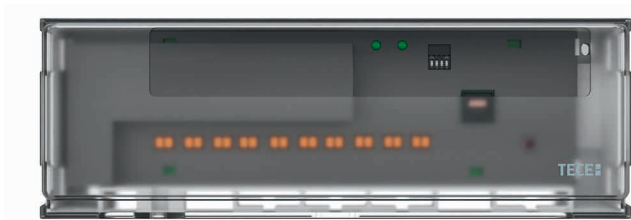

2.3 Prva instalacija

Postoje 2 načina za instaliranje kontrolera

- Montaža na zid s 2 vijka.
- Postavljen na DIN šinu

3. IDENTIFIKACIJA PROIZVODA

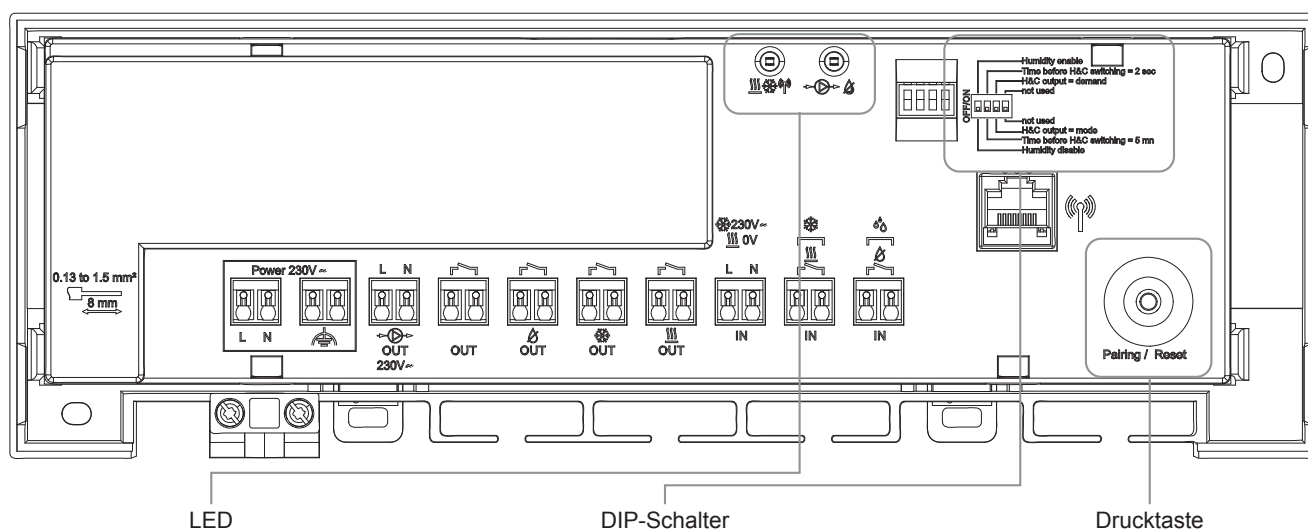

3.1 Značenja LED boja (crveno)

LED diode	Značenje
Grijanje i hlađenje i RF LED (crveno/plavo/zeleno)	Fiksno crveno = način grijanja Fiksno plavo = rad hlađenja Treperenje crveno/plavo = gubitak RF-a (Kada se RF izgubi, SH-HCM se prebacuje na način grijanja i pokreće pumpu) Trepćuće zeleno = RF komunikacija
LED pumpa / odvlaživač / greška (Crveno/plavo/zeleno)	Trepće crveno = NTC greška Treperenje plavo = globalna detekcija vlage (u ovom slučaju aktivira se odvlaživač) Popravi Zeleno = Pumpa je pokrenuta Trepere zeleno/plavo = Otkrivanje globalne vlažnosti i aktivacija pumpe Trepere zeleno/crveno = pumpa je okinula i NTC greška Treperenje crveno/plavo/zeleno = Globalna detekcija vlažnosti i aktivacija pumpe i NTC pogreška

3.2 Gumb (zeleno)

Pritiskom na 10 s pokreće se proces uparivanja
Pritiskom 20 s pokreće se resetiranje uređaja.

3.3 Konfiguracija DIP prekidača (narančasto)

Dip prekidač	funkcija	Vrijednost (Zadano: OFF)	Konfiguration	Opis
(Zadano: OFF)	funkcija vlažnosti	OFF	Onemogućeno	Vidi 4.4 i 4.5
		ON	aktiviran	
DIP2	Prebacivanje grijanje/hlađenje	OFF	5 minuta	Vidi 4.2
		ON	2 sekunde	
DIP3	izlazi grijanje i hlađenje	OFF	Prema načinu rada	Vidi 4.6
		ON	Na zahtjev	
DIP4	vlažan ulaz	OFF	Besplatan unos kontakata	Vidi 4.4
		ON	NTC senzor	

4. ULAZI/IZLAZI

4.1 napajanje

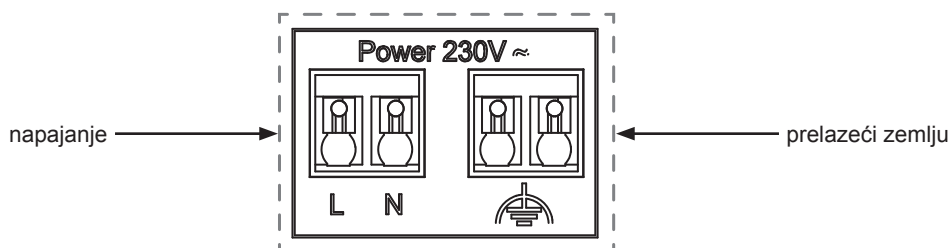

4.2 prelazeći zemlju

Ovaj ulaz omogućuje promjenu načina upravljanja za sustav: grijanje ili hlađenje.

Izvor signala:

- Mehanički prekidač
- Dizalica topline
- SH-SM spojen na SH-CU središnju jedinicu kao ON/OFF uređaj. Ovo rješenje omogućuje daljinsko upravljanje načinom grijanja/hlađenja iz aplikacije ili s korisničkog računala.

Format signala: Ulaz može biti slobodni kontakt ili kontakt pod naponom od 230 V.

način rada	Besplatan kontakt	živi kontakt
Grijanje	Otvoren	Nema signala
hlađenje	Zatvoreno	230 Vac

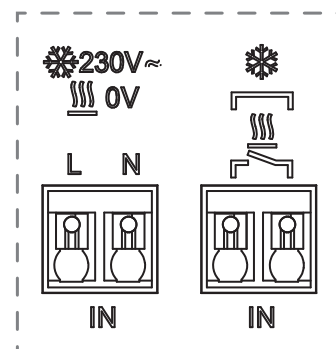

H&C mod se prenosi na cijeli sustav. Samo jedan uređaj u sustavu trebao bi moći odabrati način H&C (glavni H&C uređaj).

Drugi mogući izvori signala za prebacivanje grijanja/hlađenja :

- SH-CU središnja jedinica
- H&C ulaz na SH-CD kontrolerima
- Digitalni termostat konfiguriran kao glavni H&C termostat u ručnom ili automatskom načinu rada.

DIP prekidač na SH-CD kontrolnoj kutiji omogućuje odabir uređaja koji je odgovoran za H&C mod (glavni H&C uređaj)

Odgoda između H&C prebacivanja definirana je preko DIP2 (vidi 3.3)

- DIP2 = OFF: 5 minuta
- DIP2 = ON: 2 sekunde

4.3 performanse pumpe

Postoje 2 izlaza:

- Izlaz kontakta pod naponom (230 Vac)
- Izlaz bez potencijala

Ovi izlazi mogu prebacivati sljedeće uređaje:

- Zonski ventil
- pumpa
- Bojler ili toplinska pumpa

2 izlaza se pokreću kada postoji zahtjev za grijanjem ili hlađenjem, koji se šalje s SH-CD kontrolera na SH-HCM. Signal crpke je uvijek globalan, tj. crpka se uključuje kada u sustavu postoji zahtjev za grijanjem ili hlađenjem. U slučaju kvara RF, crpka će biti stalno uključena.

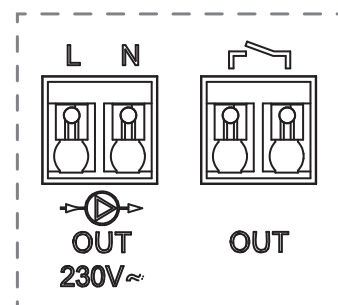

4.4 Ulaz za detekciju vlažnosti

Ako je DIP1 = ON (pogledajte 3.3), uređaj upravlja ulazom detekcije vlažnosti, s 2 moguće vrste signala, ovisno o DIP4 (pogledajte 3.3):

- Senzor temperature vode (NTC 10 k Ω): Zahtijeva SH-DTH termostat
- Senzor za kontakt s vlagom

Kontaktni senzor vlage (kontrolor točke rosišta)

Format signala: Ulaz je slobodan kontakt

Nema vlage	otvoreni kontakt
otkrivena vlažnost	zatvoreni kontakt

Kada sonda detektira vlagu, informacija se šalje SH-CD kontroleru, koji upravlja informacijama. Osim toga, aktivira se izlaz odvlaživača.

Senzor temperature vode

Izmjerena temperatura vode šalje se svim SH-CD kontrolerima za izračunavanje točke rosišta za kontrolu vlažnosti u načinu hlađenja (pogledajte upute za SH-CD)

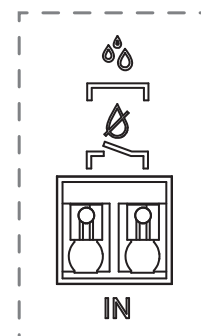

4.5 Izlaz odvlaživača

Kada je DIP1 = ON (pogledajte 3.3), izlaz odvlaživača (slobodan kontakt) aktivira se u 2 slučaja:

- Ako se aktivira unos vlažnosti (pogledajte 4.4)
- Kada upravljački razdjelnik SH-CD zatraži odvlaživač

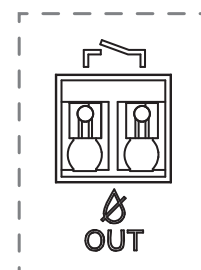

4.6 snage grijanja i hlađenja

Ponašanje izlaza (slobodan kontakt) ovisi o DIP3 (vidi 3.3):

- DIP3 = OFF: Izlaz „grijanje“ ili „hlađenje“ stalno je aktiviran ovisno o načinu rada sustava (grijanje ili hlađenje).
- DIP3 = ON: Izlaz grijanja/hlađenja se aktivira kada u sustavu postoji zahtjev za grijanjem ili hlađenjem.

U slučaju kvara RF, izlaz grijača se neprekidno aktivira.

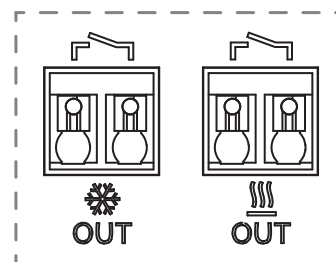

4.7 Vanjska antena

Udaljenost između 2 uređaja s unutarnjom antenom mora biti najmanje 50 cm.

U upravljač je ugrađena unutarnja antena. Ako je potrebno, može se spojiti vanjska antena za poboljšanje RF komunikacije. Ovo može biti korisno ako je upravljač instaliran u metalnom kućištu. U tom slučaju morate instalirati vanjsku antenu izvan metalnog kućišta.

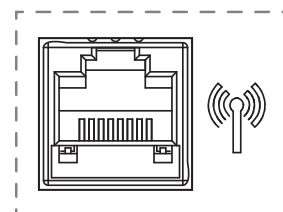

Pridržavajte se uputa za instalaciju kako biste optimizirali domet i izbjegli kvarove.

Antena mora biti instalirana na sljedeći način:

- izvan metalnog kućišta
- u okomitom položaju i najmanje 50 cm udaljen od metalnih dijelova

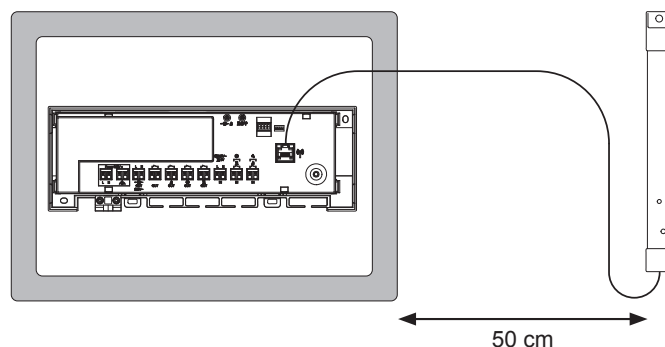

5. SISTEMSKA KONFIGURACIJA

SH-HCM uvijek treba biti uparen s SH-CD kontrolerom, čak i ako koristite SH-CU. Uvijek postoji samo jedan SH-HCM po sustavu.

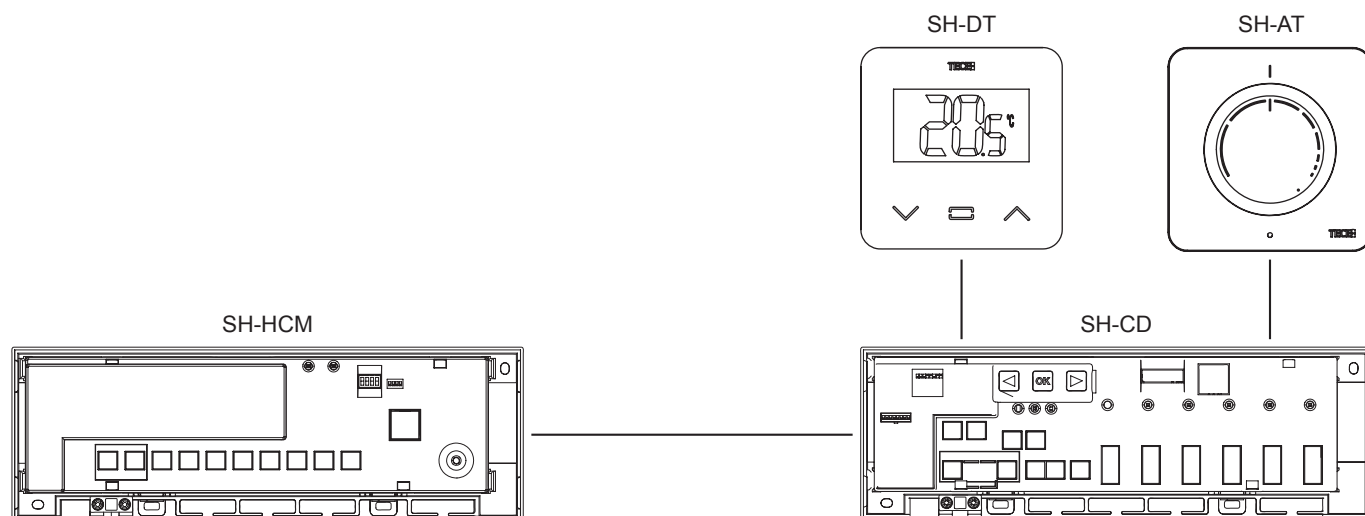

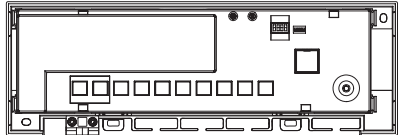
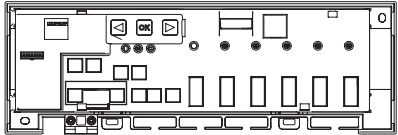
Uređaj 1: SH-HCM	Uređaj 2: SH-CD6-230	Opaske
 <p>Stavite uređaj u način RF uparivanja. Pritisnite tipku 10 sekundi.</p>	 <p>Pritiskom OK na 5 sekundi kontroler će se staviti u način RF uparivanja. Koristite ili ◀ za odabir ▶ zone 3 (LED treperi crveno) i pritisnite OK za ulazak u mod uparivanja pomoćnih uređaja. Sve LED diode trepću zeleno.</p>	<p>Kada se veza uspostavi, SH-CD vraća se u izbornik RF uparivanja, a SH-HCM vraća se u normalni način rada.</p>

6. RJEŠAVANJE PROBLEMA

simptom	problema	Opis	rješavanje problema
Bljeskanje crveno/plavo za grijanje i hlađenje i RF LED	RF problem	SH-HCM izgubio je vezu s SH-CD .	Provjerite udaljenost između uređaja. Ako je uređaj instaliran u metalnom kućištu, koristite vanjsku antenu koja se nalazi izvan metalnog kućišta. Vanjska antena također je korisna kada postoji velika udaljenost između uređaja. Korištenje vanjske antene na SH-CD i SH-HCM poboljšava RF komunikaciju. uporaba repetitora uparenog s SH-CD .
LED pumpa/vlažnost treperi crveno	NTC greška	Ako je DIP4 = ON, senzor temperature vode treba biti spojen na ulaz vlažnosti.	Provjerite postavku DIP4 i NTC

7. TEHNIČKE KARAKTERISTIKE

7.1 Tehnički podaci

	SH-HCM
električna zaštita	Klasa II sa funkcionalnim uzemljenjem
IP zaštita	IP 30
temperatura transporta i skladištenja	-10 °C do 50 °C (14 °F do 122 °F)
napajanje	230 Vac ± 10% 50 Hz
Maksimalno izlazno opterećenje (5 izlaza)	Releji: 5 A
kompatibilnost	SH-CD6-24, SH-CD10-24, SH-CD6-230, SH-CD10-230

7.2. mjere i težinu

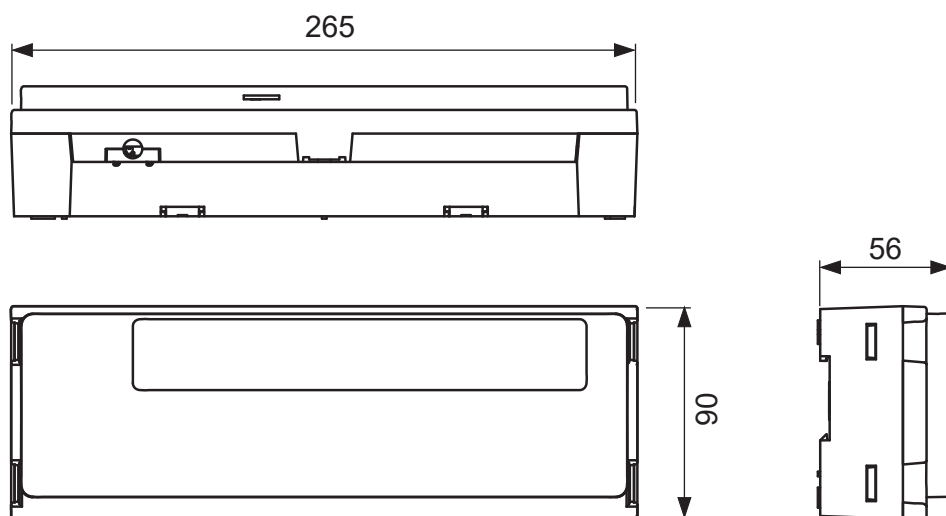

Težina: 820 g

8. Težina

Oznaka	Opis	veza
Direktiva o niskom naponu (LVD)	Direktiva o niskom naponu (2014/35/EU) osigurava da električna oprema unutar određenih naponskih granica nudi visoku razinu zaštite za europske građane i u potpunosti iskorištava prednosti unutarnjeg tržišta.	2014/35/UE
Elektromagnetska kompatibilnost (EMC) Direktiva 2014/30/EU	Direktiva 2014/30/EU o elektromagnetskoj kompatibilnosti (EMC) osigurava da električni i elektronički uređaji ne stvaraju elektromagnetske smetnje niti da one na njih ne utječu.	2014/30/UE
Ograničenje uporabe određenih Direktiva o opasnim tvarima (RoHS) 2011/65/EU	Pravila koja ograničavaju korištenje određenih opasne tvari u električnoj i elektroničkoj opremi Oprema.	2011/65/EU
Električni otpad & Elektronička oprema Direktiva (WEEE)	Direktiva WEEE (2012/19/EU) ima za cilj smanjiti količinu WEEE koja ide na odlagalište.	2012/19/EU
Komisija za ekološki dizajn regulacija	Zahtjevi za ekološki dizajn za lokalne grijače prostora.	2015/1188
Direktiva o radijskoj opremi (RED) 2014/53/EU	Direktiva o radijskoj opremi 2014/53/EU (RED) definira pravni okvir za stavljanje radijske opreme na tržište.	2014/53/EU

Conținut

1. INFORMAȚII GENERALE	76
1.1 Avertismente de siguranță și instrucțiuni de utilizare	76
1.2 Aplicație	76
2. PREZENTARE	76
2.1 Funcții	76
2.2 Conținutul cutiei	77
2.3 Prima instalare	77
3. DESCRIEREA PRODUSULUI	77
3.1 Semnificații ale culorii LED	77
3.2 Buton de apăsare	78
3.3 Configurația comutatorului DIP	78
4. INTRĂRI / IEȘIRI	78
4.1 Sursa de alimentare	78
4.2 Încălzire/răcire Intrare	78
4.3 Pompa de ieșire	79
4.4 Intrare de detectare a umidității	79
4.5 Ieșirea dehumidificatorului	79
4.6 Putere de încălzire și răcire	80
4.7 Antenă externă	80
5. CONFIGURAȚIA SISTEMULUI	80
6. REZOLVAREA PROBLEMELOR	81
7. CARACTERISTICI TEHNICE	81
7.1 Date tehnice	81
7.2 Dimensiuni și greutate	82
8. DIRECTIVE	82

1. INFORMAȚII GENERALE

1.1 Avertismente de siguranță și instrucțiuni de utilizare

Acest produs trebuie instalat de preferință de către un profesionist calificat. Sub rezerva respectării termenilor de mai sus, producătorul își asumă răspunderea pentru echipament conform prevederilor legale.

Toate instrucțiunile din acest manual de instalare și utilizare trebuie respectate atunci când se lucrează cu regulatorul. Defecțiunile datorate instalării necorespunzătoare, utilizării necorespunzătoare sau întreținerii necorespunzătoare anulează răspunderea producătorului.



Orice încercare de reparare anulează responsabilitatea și obligația de garanție și de înlocuire din partea producătorului. 2012/19/UE (Directiva WEEE): Produsele marcate cu acest simbol nu pot fi eliminate ca deșeuri municipale nesortate în Uniunea Europeană. Pentru o reciclare corespunzătoare, returnați acest produs furnizorului local la achiziționarea unui echipament nou echivalent sau aruncați-l la punctele de colectare desemnate. Pentru mai multe informații, consultați: www.recyclethis.info

1.2 Aplicație

Controlerul a fost proiectat pentru a fi utilizat în camere rezidențiale, spații de birouri și instalații industriale. Verificați dacă instalația este conformă cu reglementările în vigoare înainte de funcționare pentru a asigura utilizarea corectă a instalației.

2. PREZENTARE

SH-HCM este special conceput pentru a controla încălzirea și răcirea în combinație cu regulatoarele SH-CD. Aplicația vizată este, astfel, încălzirea și răcirea pardoselii cu apă în 2 conducte și mai multe zone. Acest dispozitiv este o opțiune și este posibil doar un singur modul pentru fiecare instalație. Acesta trebuie instalat în apropierea surselor de încălzire și răcire, în timp ce regulatoarele SH-CD trebuie instalate în apropierea colectoarelor. Dispozitivul este o opțiune cu 3 propuneri de valori principale:

- Semnal separat de încălzire și răcire
- Control global al dehumidicatorului
- Control global al modului de încălzire și răcire

2.1 Funcții

Acesta a integrat mai multe funcții:

- Montat pe perete sau montat pe șină DIN
- Conexiuni de cablu cu descărcare de efort
- Indicarea stării cu LED-uri și comutator DIP pentru setarea dispozitivului
- Intrare H&C (230 V și semnal fără tensiune)
- Intrare umiditate (contact fără volți) sau măsurare a temperaturii apei (sonda nu este furnizată) pentru detectarea umidității
- Leșirea dehumidicatorului
- Leșirea pompei sau a boilerului (230 V și semnal fără tensiune)
- Puterea de încălzire și puterea de răcire
- Antenă RF internă, antenă externă opțională

2.2 Conținutul cutiei



2.3 Prima instalare

Există 2 moduri de a instala controlerul:

- Se montează pe perete cu ajutorul a 2 șuruburi
- Montat pe o șină DIN

3. DESCRIEREA PRODUSULUI

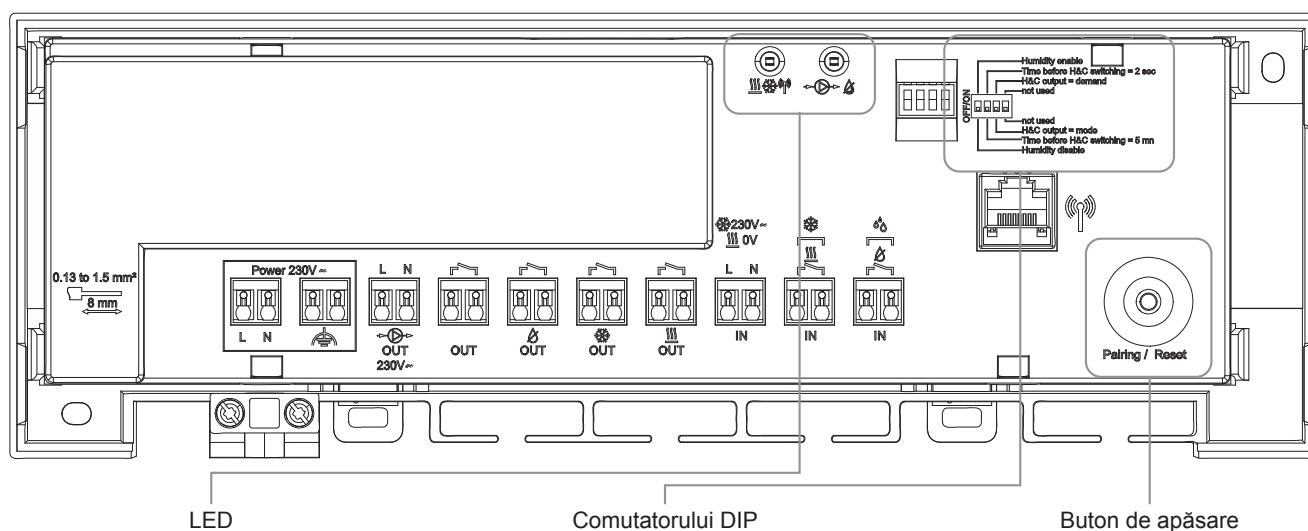

3.1 Semnificații ale culorii LED

LED	Adică	
Încălzire și răcire și LED RF (roșu/albastru/verde)	Fix Red =	Modul de încălzire
	Fix Blue =	Mod de răcire
	Roșu/Albastru intermitent =	Pierdere RF (în caz de pierdere RF, SH-HCM trece în modul Încălzire și declanșează pompa)
	Verde intermitent =	Comunicare RF
LED de pompă/umiditate/erori (roșu/albastru/verde)	Roșu intermitent =	Eroare NTC
	Albastru intermitent =	Detectarea umidității globale (în acest caz, se declanșează dezumidificatorul)
	Fix Verde =	Pompa este declanșată
	Verde/albastru intermitent =	Detectarea umidității globale și activarea pompei
	Verde/Roșu intermitent =	Pompa este declanșată și eroare NTC
	Roșu/Albastru/Verde intermitent =	Detectarea umidității globale și activarea pompei și eroare NTC

3.2 Buton de apăsare

Apăsarea a 10 s declanșează procesul de împerechere.

O apăsare de 20 de secunde declanșează resetarea dispozitivului.

3.3 Configurația comutatorului DIP

Numărul comutatorului DIP	Funcția	Valoare	Konfiguration	Beschreibung
(implicit: OFF)	Configurație	Descriere	Dezactivați	A se vedea e 4.4 și 4.5
		ON	Activați	
DIP2	Comutator H&C	OFF	5 minute	A se vedea 4.2
		ON	2 secunde	
DIP3	Modul de ieșire H&C	OFF	Mod	A se vedea 4.6
		ON	Cerere	
DIP4	Intrarea umidității	OFF	Intrare liberă de contact	A se vedea 4.4
		ON	Senzor NTC	

4. INTRĂRI / IEȘIRI

4.1 Sursa de alimentare

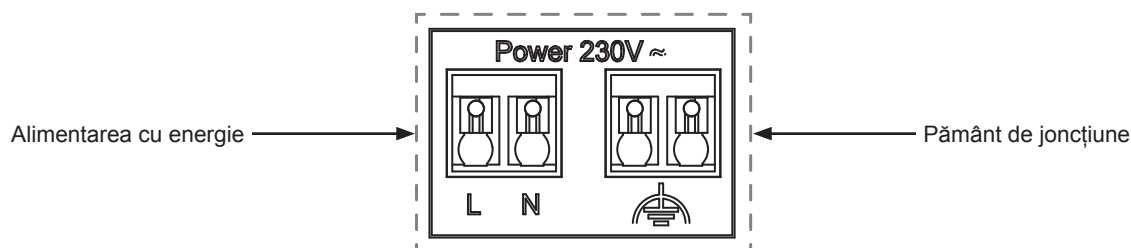

4.2 Încălzire/răcire Intrare

Această intrare permite comutarea modului de reglare a sistemului: Încălzire sau răcire.

Sursa semnalului:

- Un comutator mecanic
- Pompa de căldură
- Un SH-SM cuplat la unitatea centrală SH-CU ca dispozitiv ON/OFF. Această soluție permite obținerea unui control de la distanță al modului H&C din aplicație.

Formatul semnalului:

Intrarea poate fi un contact liber sau un contact sub tensiune de 230 V

Mod	Contact liber	Contact live
Încălzire	deschis	Nici un semnal
Răcire	Închis	230 V AC

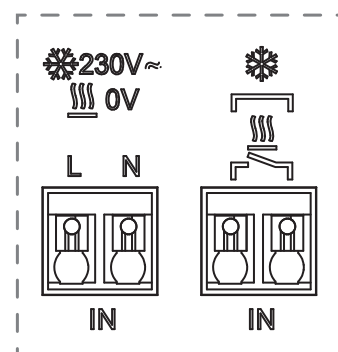

Modul H&C este apoi propagat în tot sistemul.

Doar un singur dispozitiv din sistem trebuie să poată selecta modul H&C (dispozitiv H&C principal). Alte surse posibile de semnal de comutare H&C:

- SH-CU Unitate centrală
- Intrare H&C pe controlorii SH-CD
- Termostat digital configurat ca termostat Master H&C în mod manual sau automat.

Comutatorul DIP de pe controlerele SH-CD permite selectarea dispozitivului responsabil de modul H&C (dispozitiv H&C principal).

Timpul înainte de comutarea H&C este definit de DIP2 (a se vedea 3.3)

- DIP2 = OFF: 5 minute
- DIP2 = ON: 2 secunde

4.3 Pompa de ieșire

Există 2 ieșiri:

- Ieșire de contact sub tensiune (230 V AC)
- Ieșire cu contact liber

Aceste ieșiri pot fi utilizate pentru a declanșa:

- O supapă de zonă
- O pompă
- Un cazan sau o pompă de căldură

Cele 2 ieșiri sunt declanșate atunci când există o cerere de încălzire sau de răcire, care este trimisă de către controlerul SH-CD către SH-HCM.

Semnalul pompei este întotdeauna global, adică pompa este declanșată atunci când există o cerere de încălzire sau răcire în cadrul sistemului.

Dacă apare o defecțiune RF, pompa este declanșată tot timpul

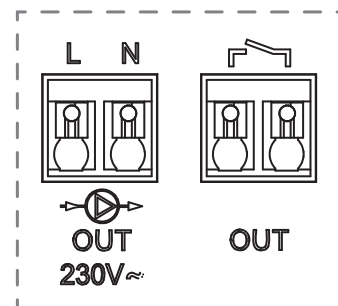

4.4 Intrare de detectare a umidității

Atunci când DIP1= ON (a se vedea 3.3), produsul gestionează o intrare de detectare a umidității, cu 2 tipuri posibile de semnal în funcție de DIP4 (Vezi 3.3):

- Senzor de temperatură a apei (NTC 10 kΩ): Necesită termostatul SH-DTH
- Un senzor de contact pentru umiditate

Senzor de contact pentru umiditate

Formatul semnalului: Intrarea este un contact liber

Fără umezeală	Contact deschis
Umiditate detectată	Contact închis

Atunci când senzorul detectează umiditatea, informațiile sunt trimise la controlerul SH-CD care gestionează informațiile. În plus, este declanșată ieșirea dezumidicatorului.

Senzor de temperatură a apei

Măsurarea temperaturii apei este trimisă la toate controlerele SH-CD pentru a calcula punctul de rouă pentru controlul umidității în modul de răcire (consultați prospectul SH-CD)

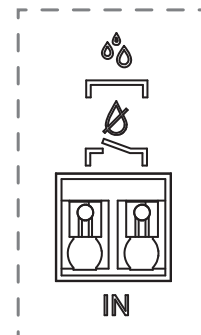

4.5 Ieșirea dezumidicatorului

Când DIP1 = ON (vezi 3.3), ieșirea dezumidicatorului (Contact liber) este declanșată în 2 cazuri:

- Atunci când este declanșată intrarea Umiditate (a se vedea 4.4)
- Atunci când controlerul SH-CD comandă dezumidicatorul

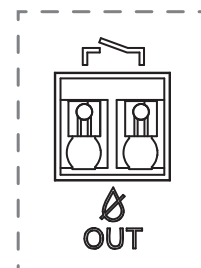

4.6 Putere de încălzire și răcire

Comportamentul ieșirilor (contact liber) depinde de DIP3 (vezi 3.3):

- DIP3 = OFF: Ieșirea de încălzire sau de răcire este declanșată în mod constant în funcție de modul de funcționare al instalației (încălzire sau răcire).
- DIP3 = ON: Ieșirea de încălzire/răcire este activată atunci când există o cerere de încălzire sau de răcire în instalație.

În cazul unei defecțiuni RF, ieșirea de încălzire este declanșată în permanență.

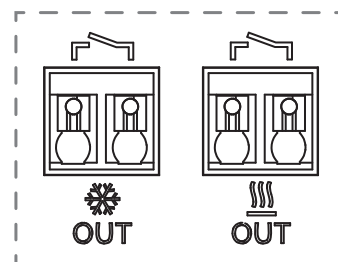

4.7 Antenă externă

Distanța dintre 2 dispozitive cu antenă internă trebuie să fie de cel puțin 50 cm.

Controlerul încorporează o antenă internă. Dacă este necesar, poate fi conectată o antenă externă pentru a îmbunătăți comunicarea RF. Aceasta ar putea fi utilă în cazul în care SH-HCM este instalat în interiorul unei cutii metalice. În acest caz, trebuie să instalați antena externă în afara cutiei metalice.

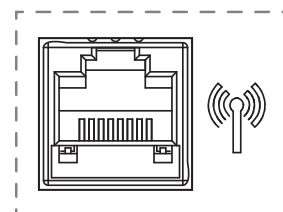

Vă rugăm să respectați montajul pentru a optimiza sensibilitatea și a evita orice disfuncționalitate.

Antena trebuie instalată:

- în afara cutiei metalice
- în poziție verticală
- și la cel puțin 50 cm de piese metalice

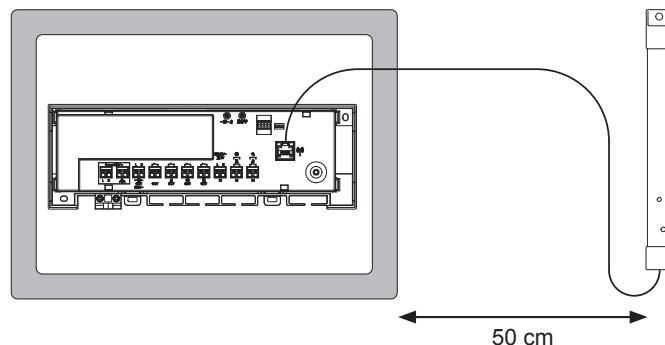

5. CONFIGURAȚIA SISTEMULUI

SH-HCM trebuie să fie întotdeauna asociat cu un controler SH-CD, chiar dacă utilizați un SH-CU. Există întotdeauna doar un singur SH-HCM pe instalație.

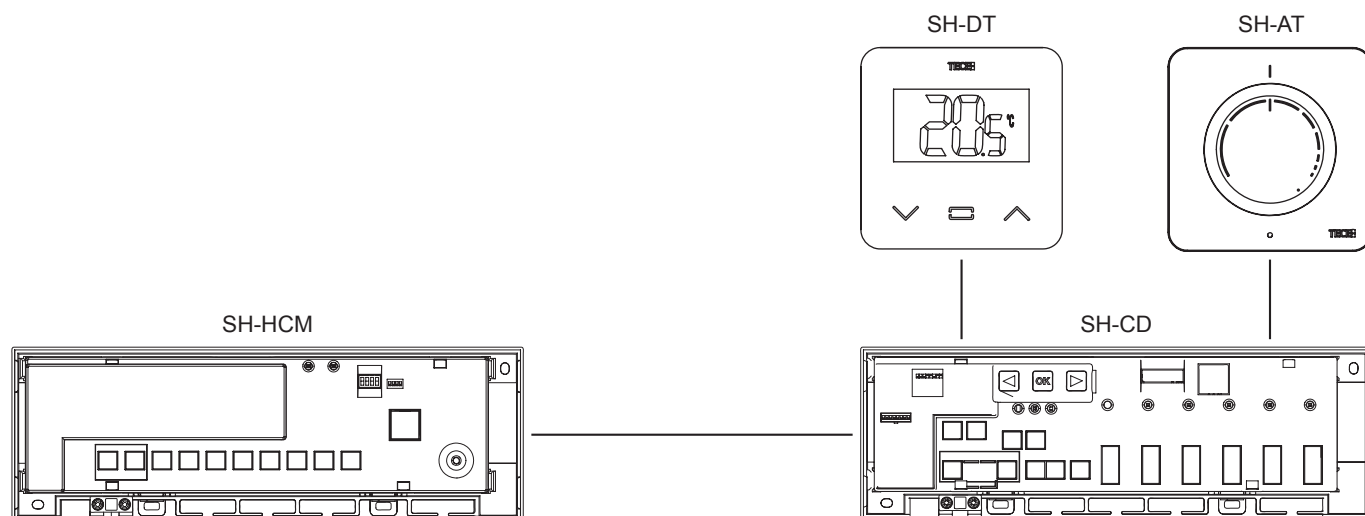

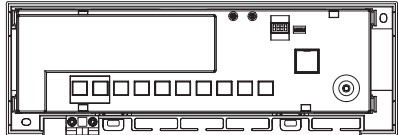
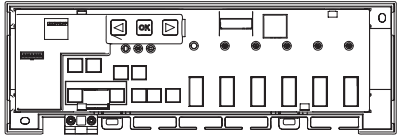
Dispozitiv 1: SH-HCM	Dispozitiv 2: SH-CD6-230	Observații
 <p>Setați dispozitivul în modul de cuplare RF. Apăsați butonul timp de 10 secunde.</p>	 <p>Prin apăsarea OK timp de 5 secunde, controlerul intră în meniul de împerechere RF.</p> <p>Cu ajutorul ◀ sau ▶ selectați zona 3 (LED-ul clipește în roșu), apăsați OK pentru a intra în modul de împerechere cu un dispozitiv sclav.</p> <p>Toate LED-urile clipeșc în verde.</p>	<p>Când legătura este realizată, SH-CD revine la meniul de asociere RF, iar SH-HCM revine la modul normal.</p>

6. REZOLVAREA PROBLEMELOR

Simptome	Probleme	Descriere	Depanarea defecțiunilor
Roșu/albastru intermitent pe LED-ul de încălzire și răcire și RF	Problema RF	SH-HCM a pierdut conexiunea cu controlerul SH-CD.	<p>Verificați distanța dintre dispozitive. Dacă dispozitivul este instalat într-o cutie metalică, utilizați o antenă externă situată în afara cutiei metalice. Antena externă este utilă și în cazul unei distanțe mari între dispozitive.</p> <p>Utilizarea unei antene externe pe SH-CD și SH-HCM îmbunătățește comunicarea RF.</p> <p>Este posibil să fie necesară utilizarea unui repetor cuplat la SH-CD.</p>
Roșu intermitent pe LED-ul pompă/umiditate	Eroare NTC	Dacă DIP4 = ON, trebuie conectat un senzor de temperatură a apei la intrarea Umiditate.	Verificați setarea DIP4 și NTC

7. CARACTERISTICI TEHNICE

7.1 Date tehnice

	SH-HCM
Protecție electrică	Clasa II cu pământ funcțional
Protecție IP	IP30
Temperatura de transport și depozitare	-10 °C la 50 °C (14 °F la 122 °F)
Alimentarea cu energie electrică	230 V AC ± 10 % 50 Hz
Sarcina maximă de ieșire (5 ieșiri)	Relev: 5 A
Compatibilitate	SH-CD6-24, SH-CD10-24, SH-CD6-230, SH-CD10-230

7.2 Dimensiuni și greutate

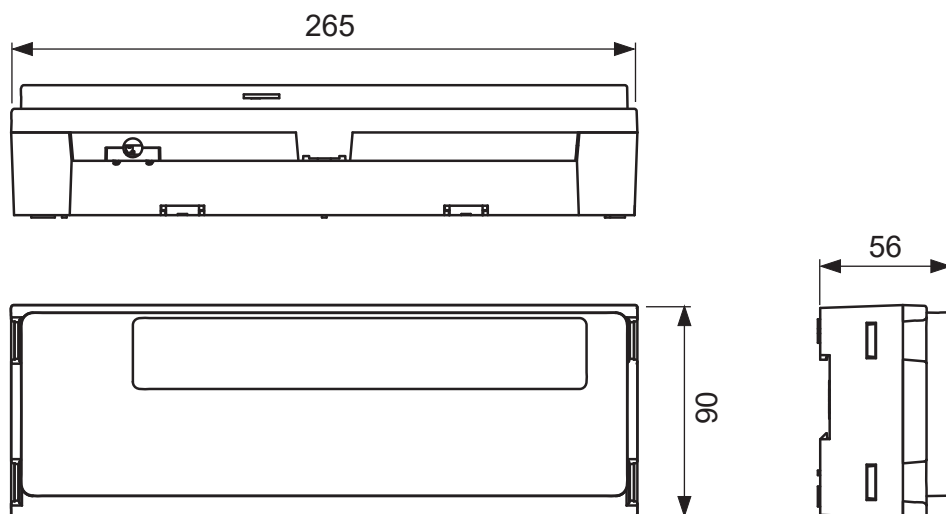

Greutate: 820 g

8. DIRECTIVE

Desemnare	Descriere	Link
Directiva privind joasă tensiune (LVD)	Directiva privind joasă tensiune (LVD) (2014/35/UE) garantează că echipamentele electrice care se încadrează în anumite limite de tensiune asigură un nivel ridicat de protecție pentru cetățenii europeni și beneficiază pe deplin de piața unică.	2014/35/UE
Compatibilitate electromagnetică (EMC) Directiva 2014/30/UE	Directiva 2014/30/UE privind compatibilitatea electromagnetică (CEM) garantează că echipamentele electrice și electronice nu generează perturbații electromagnetice sau nu sunt afectate de acestea.	2014/30/UE
Restricția de utilizare a anumitor Directiva privind substanțele periculoase (RoHS) 2011/65/UE	Directiva privind restricțiile de utilizare a anumitor substanțele periculoase din instalațiile electrice și electronice echipamente.	2011/65/UE
Deșeurile electrice & Echipamente electronice Directiva (WEEE)	Directiva DEEE (2012/19/UE) are ca scop reducerea cantității de deșeurile de echipamente electrice și electronice care ajung la groapa de gunoi.	2012/19/UE
Comisia pentru proiectare ecologică Regulamentul	Cerințe de proiectare ecologică pentru încălzitoarele locale.	2015/1188
Directiva privind echipamentele radio (RED) 2014/53/UE	Directiva 2014/53/UE privind echipamentele radio (RED) stabilește un cadru de reglementare pentru introducerea pe piață a echipamentelor radio.	2014/53/UE

TECE GmbH
Germany
T + 49 25 72 / 9 28 - 0
info@tece.com
www.tece.com