

TECE
close to you

Piping systems

**TECEflex –
SAFE. SIMPLE.
UNIVERSAL.**





“Any piping system I install should last at least 50 years. After all, most of it disappears deep into the structural shell. For me, quality and maximum reliability come first.”



SYSTEMS COME AND GO. TECEflex HAS BEEN HERE SINCE 1992.

How can you tell a real classic? Years later, it is just as contemporary as it was on the first day. It never fails to impress new customers. And its features remain relevant without exception. All these things are true of TECEflex. Because TECEflex continues to meet customer requirements for fault-tolerant workmanship and maximum reliability. Without a doubt: TECEflex is “The classic”.

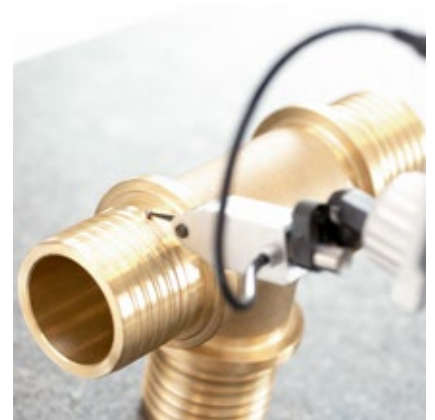

CONTENTS

04 **Reliability**

06 Safety pays off

08 **Simply designed**

10 Sleeve technology

12 Making a connection

14 Tools

16 Multi-layer composite pipe

18 Fittings

20 Application areas

22 Variety of solutions

24 **Safety in the system**

26 Quality tested

SAFE. SIMPLE. UNIVERSAL.

RELIABILITY.

Something that never goes out of fashion.

TECEflex customers choose the system for financial reasons.

Their decision is always based on outstanding system reliability. It's not about small leakages, which fortunately show up in the pressure test in many systems, but about major leaks and pipe breaks which occur every year hundreds of times after weeks, months or years after the building has been handed over.

Fortunately not a daily problem, but when this kind of damage does occur, it always entails very high costs, a lot of time, considerable damage to the image and in particular the question: who's going to pay for it?



A FALSE ECONOMY?

We have the solution that pays off in the long run.

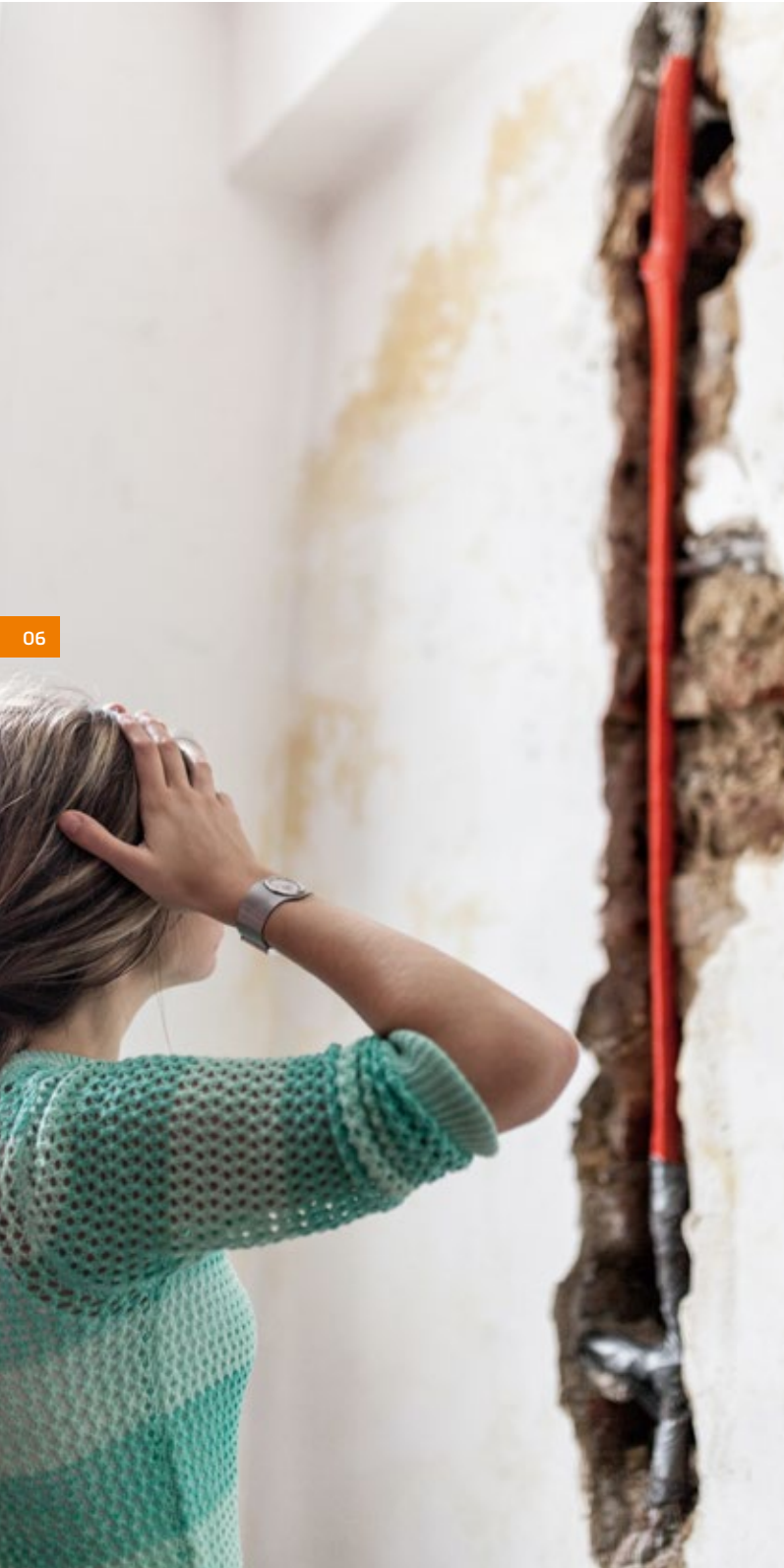

€ 2,300,000,000

That's the annual claims figure that German insurance companies have to pay out for tap water damage. And the trend is on the rise. This doesn't even include damage that installation companies fix at their own expense.

Source: Association of the German Insurance Industry

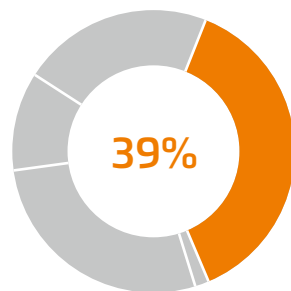

Causes of tap water damage

39% of all damage is due to installation and assembly errors. Faulty press connections are a major cause of damage.

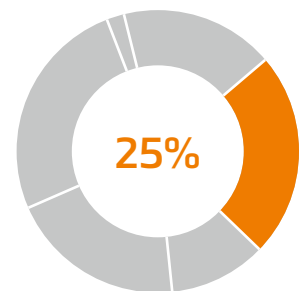

System parts affected

Although we often think of pipe bursts being the cause of water damage, statistics show that leaky connections are actually frequently the cause, accounting for 25% of all damage.

Source: German Institute for Loss Prevention and Loss Research of Public Insurers, Loss Database 2003-2019

“When it comes to pipe installation, I want absolute security in terms of workmanship and quality, because if there is any damage, my only option is to pry open the floor or the wall. I prefer quality from the start, without the stress afterwards.”



Where **SHOULDN'T** you save?

You won't save much by skimping on pipe and fitting materials. That's because these represent a very small part of the overall installation (ceramics, boiler, fixings, bathroom furniture, etc.). The risk of making a mistake with high incidental damages however is significant.

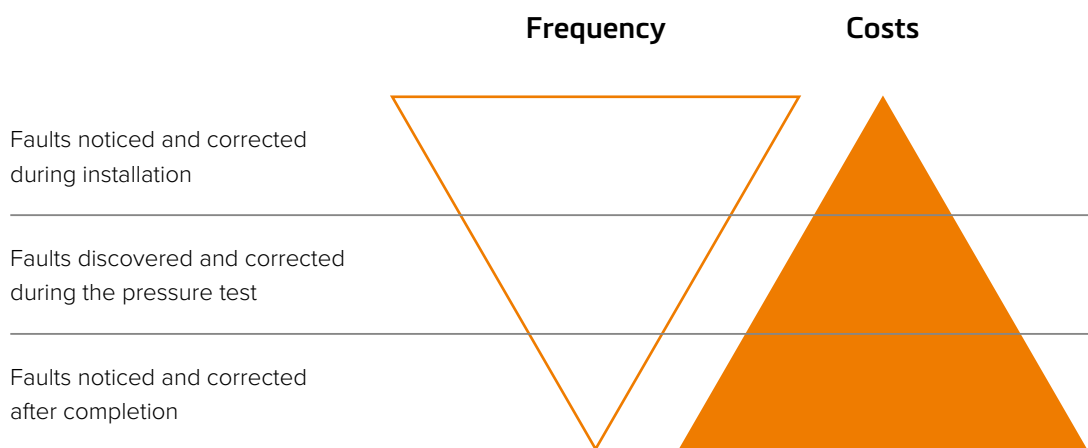

Where can you save?

In the long term, you save costs and nervous energy by relying on a fault-tolerant and high-quality piping system from the start. This reduces the workmanship and damage risk.

SAFE. SIMPLE. UNIVERSAL.

SIMPLY DESIGNED, SYSTEMATICALLY SUPERIOR.

The classic in detail.

With proven advantages over 25 years. Technically always state-of-the-art.

Modern classics are able to transfer the experience and advantages of the past into the present, learn from them and adapt to changing conditions. This is exactly what we have done with TECEflex: we have not changed our workmanship reliability and fault tolerance for over 25 years. But we have always adapted quickly to changing conditions. For example, to new potable water regulations requirements.

These aspects have permanently been incorporated into the system immediately.

So you can always be sure: With TECEflex you are always compliant with standards and legislation – as well as the requirements of construction site practice. Let the extraordinary features inspire you.



SIMPLY DESIGNED, SYSTEMATICALLY SUPERIOR

EXPAND, PRESS, TIGHT. REALLY TIGHT.

Sleeve technology

TECEflex tradespeople know: for decades no leaky connections, no discussion about zeta values and no risk of confusion with O-rings. This is what makes sleeve technology the safest and most respected type of connection for plastic pipes, even in the 21st century.

Sleeve technology also means that it is impossible to forget a work step. Because without expanding you can't get the pipe pushed onto the connector. And without pressing, you will find out at the latest during the pressure test that you have re-work to do.

Simply tight, without an O-ring

The expansion and subsequent pressing and reshaping of the pipe by the sleeve creates a non-positive and form-fitting sealing surface over the entire pressing area.



“With TECEflex, the tool has only a minor bearing on the quality of the sleeve connection. Quite unlike conventional radial press systems, where the press jaws have to be really clean and wear-free in order to form a sealing contour into the press sleeve with the correct press pressure. In the past, O-rings were usually thicker, so pressing was not about sealing, they were already tight when inserted. Today's “unpressed untight fittings” are much more sensitive. And in the event of damage, it must be possible to demonstrate that everything is regularly serviced. That is a great deal of organisational effort using several tool sets. With TECEflex I know from experience: sleeve on, sealed!”



Security of workmanship at a glance

With sleeve technology, at a glance you can see that you have made the connection correctly: Sleeve on = sealed!



SIMPLY DESIGNED, SYSTEMATICALLY SUPERIOR

SIMPLE INSTALLATION, MAXIMUM SAFETY.



Forming a TECEflex connection

Expanding, axial pressing and the quality of the connection should be achieved regardless of the quality of the tool. With TECEflex you get a system through which you deliver quality step by step.



Step 1: Expand just once

Admittedly, expanding is an additional step compared to radial pressing. Long-standing TECEflex customers know that this is the basis for the outstanding reliability and fault tolerance of this system.

Years of working without a single leak are the impressive proof of this. It also forms connections with large inner diameters and excellent flow properties. In short: Expanding is 100% worth the effort!

Step 2: Axial pressing

Here, the expanded pipe end is forcefully formed by the sleeve and pressed to the special TECEflex fitting contour. The connection is then water and gas tight and therefore ideally suited for potable water, heating, compressed air and gas. And the great thing about it: everything with the same metal fitting!



Removing a TECEflex connection

Sometimes it's easy for the wrong fitting to get pressed onto the pipe at construction sites. This is not an issue with TECEflex metal fittings, because the connection can be released with hot air. Naturally, the fitting can then be reused.

SIMPLY DESIGNED, SYSTEMATICALLY SUPERIOR

YOUR TECEflex TOOL. IN USE EVERY DAY.

Hand tools

Always ready to use

You can easily form sleeve connections up to 32 mm with the TECEflex range of hand tools. All you need is an expanding and pressing tool. What you don't need are electricity, batteries or expensive maintenance costs for the tools.



RAZ-V pipe expansion tool

Pipe ends can be expanded quickly and easily with this manual tool. There is no need to mark the insertion depth.



Press everything from 16 - 32 mm with a single tool

It's simple: with the HPW-L manual pressure sleeve pressing tool. Just replace the fork heads and the tool is ready to use in any position thanks to flexible chain hoists and an articulated arm.

No searching and nothing to forget

Both tools are housed in the sturdy tool case, which means you can start working on the construction site straight away.



Electrical tools

Small and handy from 16 - 32 mm

With the two battery-operated TECEflex Raz-Faz tools for expanding and pressing, you can form sleeve connections even in tight installation areas or very close to walls. The pressing tool has a double pressing fork which means you can work with two dimensions without changing.



You can also work bigger

The TECEflex range offers you the PMA tool set for dimensions from 40 - 63 mm. This is compatible with standard pressing machines with a compression force of 32 kN. This retains the full functionality of the pressing machine. And of course the same applies to this tool:

Sleeve on = sealed!



EXTRA THICK FOR EXTRA SAFETY.

The composite pipe – a sensation in its day

The forerunner of TECEflex was already on the market in the mid-1980s: as an aluminium-coated, oxygen-tight underfloor heating pipe. Back then, however, you could only obtain certification for all-plastic pipes. A plastic pipe was therefore developed as an internal pipe that already met all pressure and temperature requirements. For dimension 16 this would be for example a 16 x 2.1 mm internal pipe. Not even today's standard aluminium composite pipes are this thick! Further layers of aluminium and polyethylene were then added on top of this internal pipe, which was already completely pressure-resistant.

Even if the outer skin on the construction site rubbed down through the aluminium or scratches went through the aluminium: the pressure-resistant internal pipe remained, already fulfilling all requirements for composite pipes.

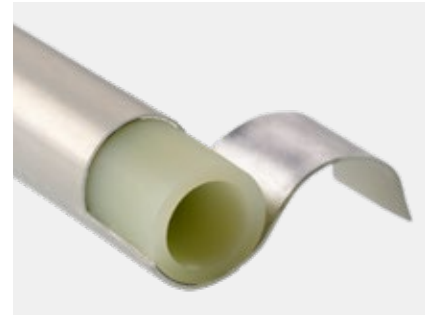

The first composite pipe from the 80s.



TECEflex multi-layer composite pipe PE-Xc/Al/PE-RT: the best of two worlds

The TECEflex multi-layer composite pipe is the ideal combination of plastic and metal. Even the electron beam cross-linked inliner is extremely pressure and temperature resistant. The aluminium casing also ensures 100% oxygen tightness and excellent dimensional stability. And with the white outer sheath, it is also perfectly equipped for use in the visible area.

Wall thickness comparison

Dimension 16



A minor scratch makes all the difference

In order to simulate a construction site scratch, a commercially available aluminium composite pipe 16 x 2.0 mm and a TECEflex pipe DIM 16 (17 x 2.75) were grooved 0.5 mm deep in the longitudinal direction in a laboratory test. The requirements of ISO 10508 - application class 2: hot water supply 70°C were then used as the basis for a creep test. This requires an accident resistance of 95°C for 100 hours at 10 bar (potable water).

The result: The commercial aluminium composite pipe burst after just 4:09 hours, while the TECEflex pipe easily withstood. After more than 1,200 hours, the test was ended without any break, because based on the standard curves, a break would only be expected in well over a hundred years.



1 Standard composite pipe
2 TECEflex composite pipe



Minimum bending radius – maximum stability

In order to fully utilise the minimum bending radius, a bending tool is also required for a TECEflex pipe. But normally you bend the TECEflex pipe over your thumb. Your thumb is sufficient as a daily work tool, since the TECEflex composite pipe is significantly less prone to buckling. Try it out yourself!

SIMPLY DESIGNED, SYSTEMATICALLY SUPERIOR

A CLASSIC FROM A SINGLE CAST, FOR MAXIMUM FLOW.

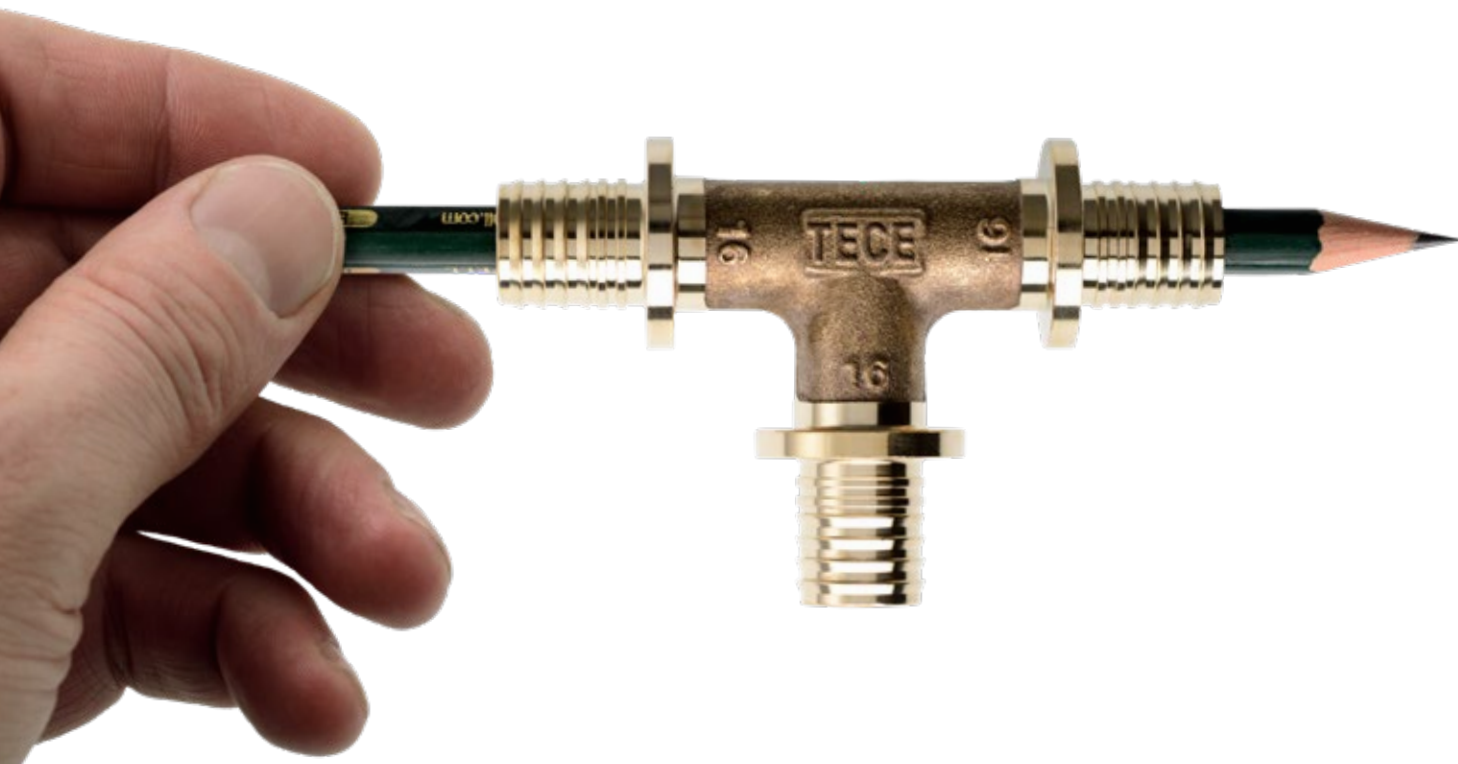

18

Take the pencil test!

The TECEflex expansion technology ensures that the pipe and fitting have almost the same internal diameter. Especially in times of zeta-value discussions, pressure-loss optimisation and minimal pipe water content, we offer the fitting which has combined all the positive properties for the pipe network hydraulics since it was launched. And with the simple pencil test you can make this visible even with a 16 mm fitting.

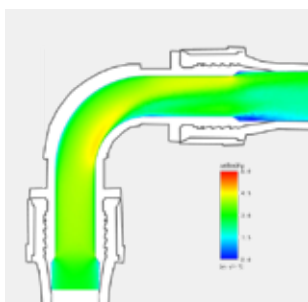

The fittings

In developing the TECEflex fittings, we placed great emphasis on optimal zeta values and a very slim design. The result: a streamlined fitting that, in conjunction with sleeve technology, sets standards in resistance values.



The TECEflex materials

The TECEflex metal fitting forms the basis for an optimal potable water, heating, gas or compressed air installation. O-ring-free and with an optimised cross-section, it makes your installation a success simply and safely. "One fitting for all" also means less inventory. The cost-effective alternative is the TECEflex fitting made from the high-performance polymer PPSU. This fitting has been part of the TECEflex range for potable water, heating and compressed air since 1999.

Tip:

TECEflex fittings are optimised for pressure loss. This means that in some cases you can plan smaller with a pipe dimension. A smaller pipe dimension has less water content. This significantly reduces the discharge times for hot water installations, for example.

ALL IN ONE.

The TECEflex metal fitting is a real all-rounder. The metal alloy not only allows the fitting to be used in potable water and heating installations. TECEflex fittings can also be used for gas and compressed air installations.

The TECEflex composite pipe combines all the advantages of metal and plastic pipes. It has a high impact strength and no crack propagation. Thanks to the oxygen barrier layer made of butt welded aluminium, the TECEflex composite pipe is fully diffusion-tight – a key advantage when it comes to heating connections.



Aluminium composite pipe with 14–63 mm dimensions

For potable water, heating and compressed air.

- As rolls or in rod form
- With and without corrugated sheath pipe
- Internal pipe consists of PE-Xc base pipe
- High pressure, temperature and corrosion resistance
- Approved for potable water, heating, compressed air



Potable water

The fittings are suitable for every potable water quality according to DIN 50930. As the TECEflex connection is free of dead spaces and no water stagnates in front of seals, this avoids recontamination after disinfection by bacteria surviving in stagnant water.



Heating

TECEflex is designed for class 5 high-temperature heating installations according to DIN EN ISO 21003. The fittings are resistant to inhibitors or glycol-based antifreeze. Please refer to our current technical information.





The TECEflex 5S pipe: the economical alternative to the composite pipe with 16 and 20 mm dimensions.

Thanks to the central oxygen barrier layer, the pipe is not only optimised for potable water and heating installations, but also withstands harsh construction site conditions. The TECEflex 5S pipe can also be used for compressed air installations, which has been confirmed by extensive TÜV tests.

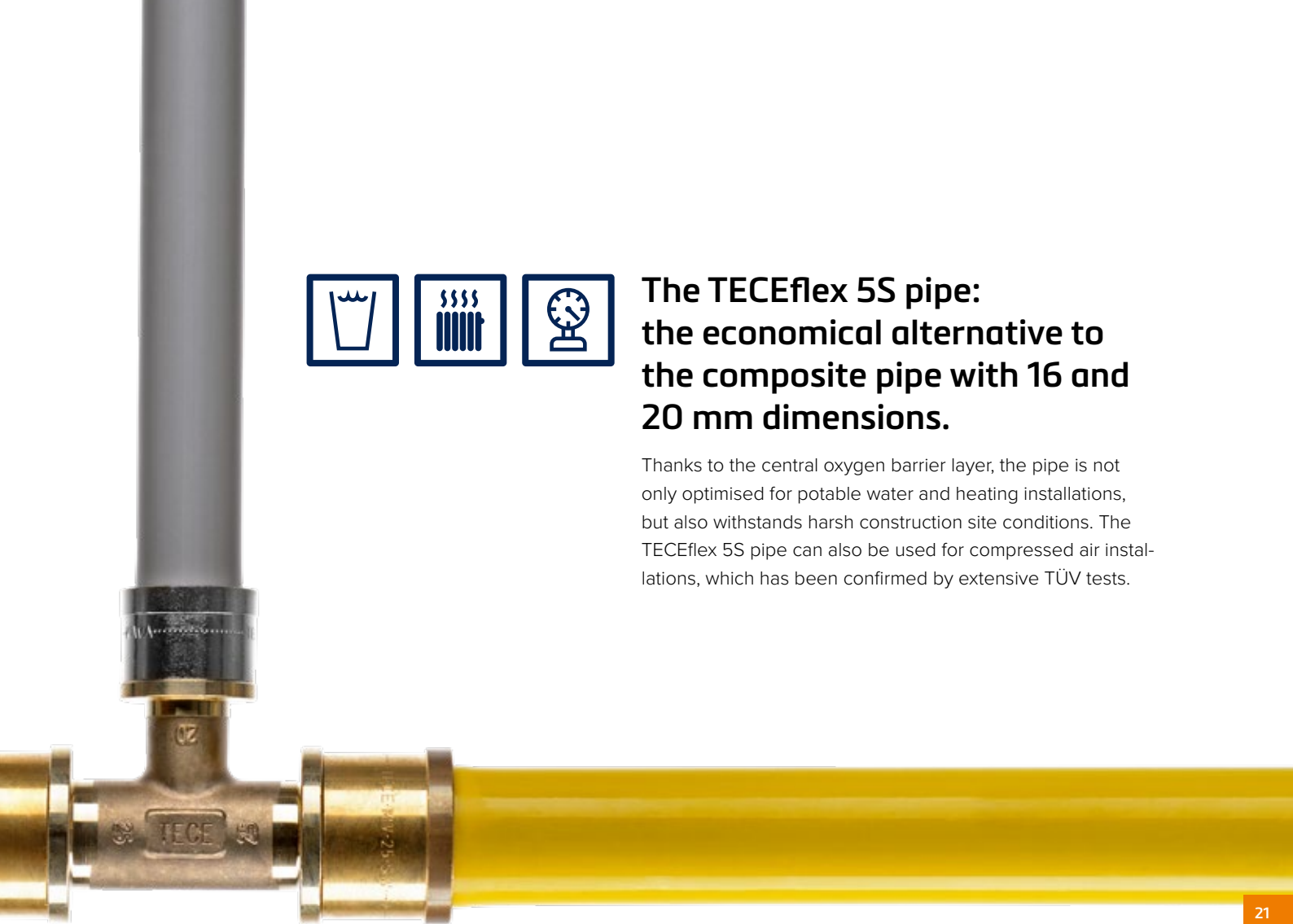

21



Aluminium composite pipe with dimensions of 16–63 mm

- Application area for internal gas installations according to TRGI 2018 and TRF 2012
- With DVGW approval up to 100 mbar for gases of the 2nd and 3rd gas family (natural and liquid gas)
- Dimensions 16–63 mm
- As rolls or in rod form
- With and without corrugated sheath pipe



Gas

With the yellow aluminium composite pipes, you can use the metal fittings to create liquid and natural gas installations inside buildings. As well as the flexible installation option, a major advantage of yellow plastic pipes is that they do not corrode. As a result, they can be laid as a gas line in unventilated or filled rooms or shafts.



Compressed air

The materials of the TECEflex system are non-sensitive to grease and oil in a compressed air installation. There are no O-rings that can swell in TECEflex connections. The TECEflex can therefore be used to create compressed air installations regardless of the oil content.

SIMPLY DESIGNED, SYSTEMATICALLY SUPERIOR

A REAL CLASSIC FITS ANYWHERE.

Practical solutions for maximum diversity.

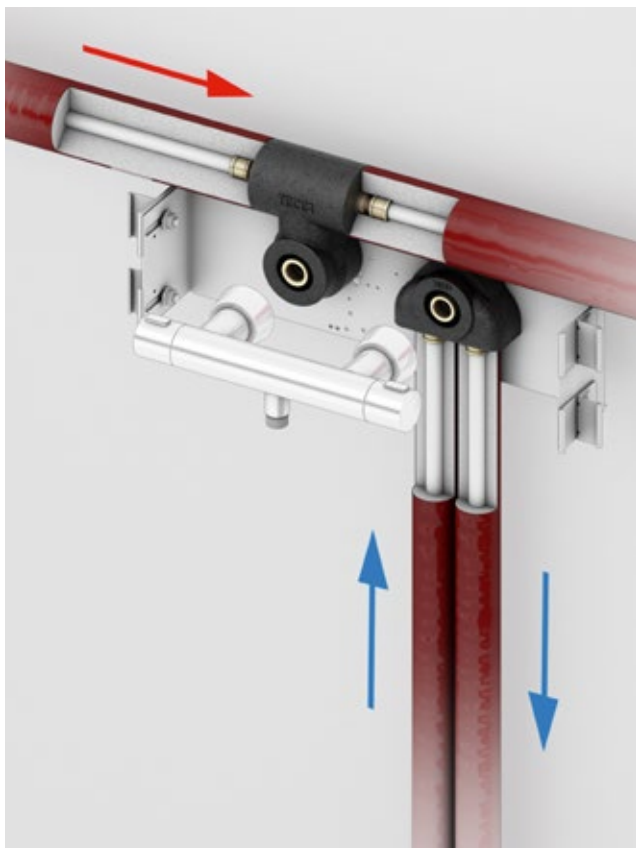

The TECEflex hygiene box

The TECEflex hygiene box thermally decouples the hot water circulation line from the fitting connection, and thereby effectively prevents heat from being transferred via the fittings to the cold water side. Made from prefabricated components, it prevents the cold water from being heated above the permissible 25 °C.

Advantages for planners and craftsmen

- Potable water regulations are automatically met – cold water stays cold.
- Prefabricated components ensure efficient assembly and reliable, safe operation.
- Insulation shells make it easier to connect the pipe insulation.
- High level of compatibility with different pipe adapters.
- Offers planners and craftsmen protection from cost-intensive complaints.

The TECEflex double wall disk

The TECEflex double wall disk ensures that fresh potable water is available at all times, even from tap fittings that are rarely used. A little extra effort during installation ensures a high level of potable water hygiene. Simply TECEflex.

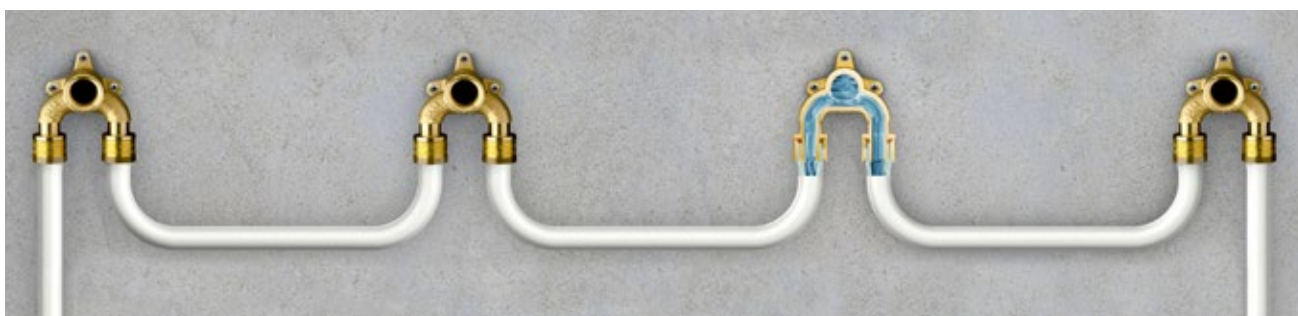

The Seal System sealing set

The sealing set for wall bushings: the professional solution for standard-compliant installations.

A modern classic also has to be able to implement changed normative requirements into practical solutions. DIN 18534, which was issued in Summer 2017 for sealing indoor spaces, also precisely defines the requirements for wall bushings above the bathtub and in the shower.

The Seal System sealing set offers additional safety: reliably sealed after the work has been handed over.

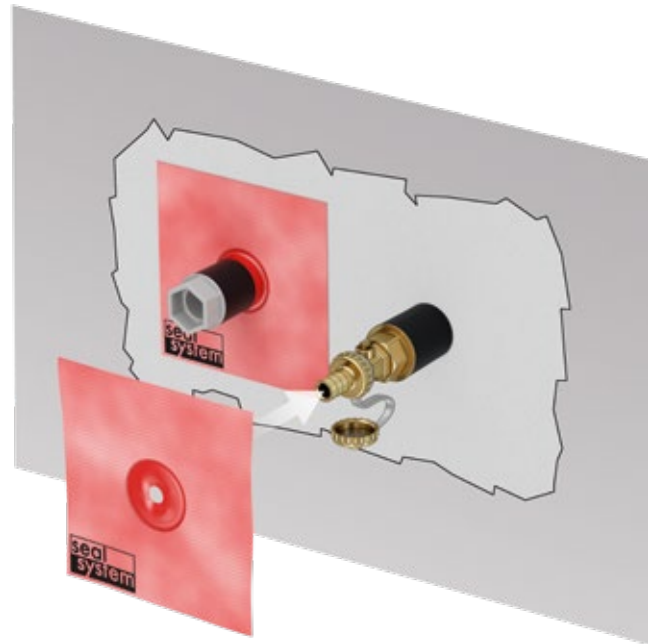

How it works:

1

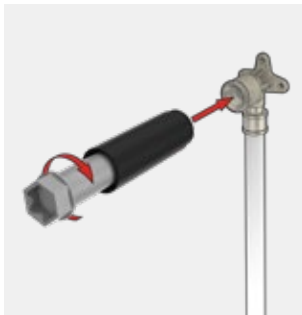

2



3



4

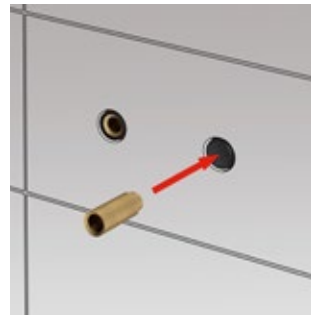

- 1 The sealing sleeve is pushed over the wall disk when the assembly plug is screwed in and seals outwards.
- 2 The sealing collar is pushed over the plug and sits directly on the sealing sleeve.
- 3 Prior to assembly of the fitting, the sealing sleeve is shortened to be flush to the wall and the reusable assembly plug is unscrewed and removed.
- 4 The valve extensions are then screwed in.



See now:
How the TECE Seal System sealing set for wall bushings works.

SAFE. SIMPLE. UNIVERSAL.

TECEflex DEMONSTRATES SAFETY IN THE SYSTEM.

In line with standards and regulations.

Proven quality from the TECE laboratory

Even a true classic has to keep proving that it still fulfils current construction site requirements and complies with standards and regulations. Our fittings and pipes are therefore continuously monitored internally and externally. The entire

system is checked time and again. All of this gives us the security of offering you the highest proven quality. Yesterday, today and in the future. Just as you would expect from a true classic.



TECEflex DEMONSTRATES SAFETY IN THE SYSTEM

CONVINCING PERFORMANCE.

For decades, TECEflex has repeatedly adapted to changing conditions and passed all requirements convincingly: this is what sets this universal classic apart.



Tested and certified

In order to authorise a piping system for potable water, heating or even the gas sector, the different requirements of the regulatory body must be met (in Germany, among others, DVGW German Association of the Gas and Water Industry). These tests are carried out both internally in the TECE laboratory and externally in various renowned institutes. Our goal: a consistently high product and connection quality.

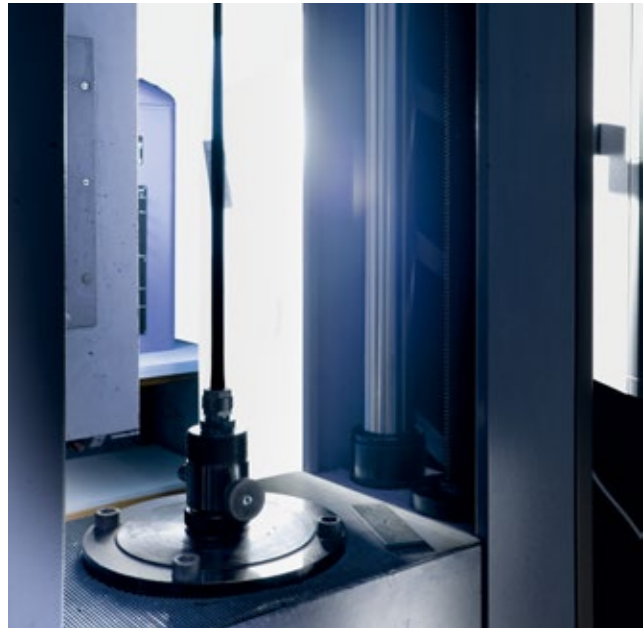

System for performing tensile tests on installation pipes



KOMO CV

kiwa



ITG



Extreme tests guarantee maximum safety

In addition to the individual tests for connectors and pipes, the connection also undergoes an endurance test at TECE's in-house temperature change test system: here the pipe systems must withstand at least 5,000 temperature change cycles of 15 minutes each between 20°C and 95°C. This normative requirement ensures that the systems optimally match the conditions in the building installation.

GET TO KNOW US BETTER.

TECE provides expertise in further areas of competence. Visit www.tece.com, where you can find detailed information about the company, products and services.



Installation & Assembly

Straightforward, stress-free work. In this brochure, professional tradesmen can discover more about well-thought-out products, quality, services and the TECE Academy.



Design & Creation

Freedom in design. The themes of Space & Architecture, Individuality & Design and Function & Technology are aimed primarily at architects and bathroom planners.



Project & Planning

Reliability in terms of time, legal aspects and economic efficiency. This brochure is intended for planners, architects and investors.

