

Pipe Systems

## TECEflex

TECHNICAL GUIDELINES

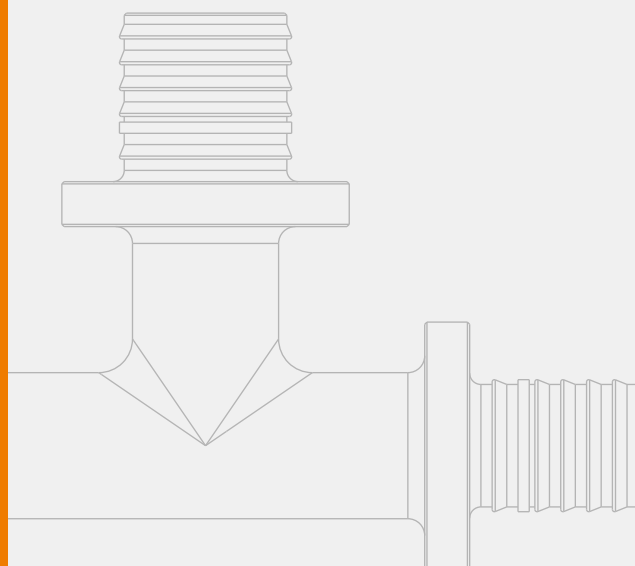

|  |             |
|--|-------------|
| <b>System Description</b>                    | <b>1-4</b>  |
| TECEflex composite pipe PE-Xc/Al/PE-RT       | 1-5         |
| TECEflex PE-Xc 5S pipe                       | 1-6         |
| TECEflex PE-MDXc 5S underfloor heating pipe  | 1-6         |
| Fittings                                     | 1-7         |
| Pressure sleeves                             | 1-8         |
| TECEflex system application limits           | 1-8         |
| <b>Areas of application</b>                  | <b>1-11</b> |
| Drinking water installation                  | 1-11        |
| Disinfection of drinking water installations | 1-12        |
| Heating installation                         | 1-13        |
| Compressed air installation                  | 1-13        |
| <b>Connection technology</b>                 | <b>1-14</b> |
| Forced leakage                               | 1-14        |
| <b>Installation information</b>              | <b>1-15</b> |
| Connection with TECEflex manual tools        | 1-15        |
| Connection with RazFaz battery-powered tool  | 1-16        |
| Connection with pressing tool PMA            | 1-18        |
| Reuse of pressed fittings                    | 1-19        |
| <b>Installation Guidelines</b>               | <b>1-20</b> |
| General notes                                | 1-20        |
| Bending radii                                | 1-21        |
| Thermal length changes                       | 1-22        |
| Attaching conduit                            | 1-23        |
| Routing of water-bearing TECEflex lines      | 1-23        |
| Sound insulation                             | 1-25        |
| Fire protection                              | 1-25        |

|  |             |
|--|-------------|
| <b>TECElogo - Planning and design</b>              | <b>1-25</b> |
| Dimensioning of drinking water systems             | 1-25        |
| Guide values and installation times                | 1-32        |
| Rinsing drinking water systems                     | 1-32        |
| Pressure test of drinking water systems            | 1-32        |
| <b>Radiator connection</b>                         | <b>1-39</b> |
| <b>Compressed air installation</b>                 | <b>1-42</b> |
| Planning of a compressed air installation          | 1-42        |
| Compressed air lines                               | 1-43        |
| Calculation basis for compressed air installations | 1-44        |
| Dimensioning                                       | 1-44        |
| Resistance list PPSU                               | 1-46        |

# TECEflex - System Description

## System Description

TECEflex is the universal installation system for drinking water, heating, compressed air and gas installations. All-plastic pipes and composite pipes are available. The pipes are connected using axial pressure sleeve technology - without using O-rings.

TECEflex offers:

- connection without an O-ring
- connections with low pressure loss using expansion technology
- high pressure and temperature resistance
- no hygiene issues
- error-tolerant and thus totally secure system
- flush-mounting possible
- dimensionally stable, bend-resistant composite pipes
- one fitting for three types of pipe - therefore no danger of a mix-up with the fittings and significantly reduced storage requirement
- axial press-connector with low cross-section constriction

### Types of pipe

The TECEflex system offers the right pipe for every installation application:

- composite pipe for drinking water, heating and compressed air applications
- composite pipe - coloured yellow - for the indoor gas installation
- PE-Xc-5S pipe for drinking water, heating and compressed air applications (with internal diffusion block)
- PE-MDXc-5S pipe for underfloor heating (with internal diffusion block)

### Electron beam cross-linking

The installation of drinking water, heating, compressed air and gas requires large amounts of pipe material. In addition to being pressure and temperature-resistant, a pipe must be resistant to chemicals and have a service life of at least 50 years. Plastic pipes made of polyethylene are cross-linked to improve their mechanical properties. The cross-linking of polyethylene entails the linkage of the long, loosely adjoining molecules in the polyethylene into a large three-dimensional macromolecule. Polyethylene molecules are very long chains of hydrocarbon compounds.

These chains loosely adjoin one another, the chains are not linked among themselves. Cohesion is only provided by low attractive forces. This two-dimensional structure is the reason that the polyethylene melts. If the plastic is heated, the chains begin to oscillate. As soon as the oscillations increase to the point at which the attractive forces are no longer sufficient, the plastic becomes fluid.

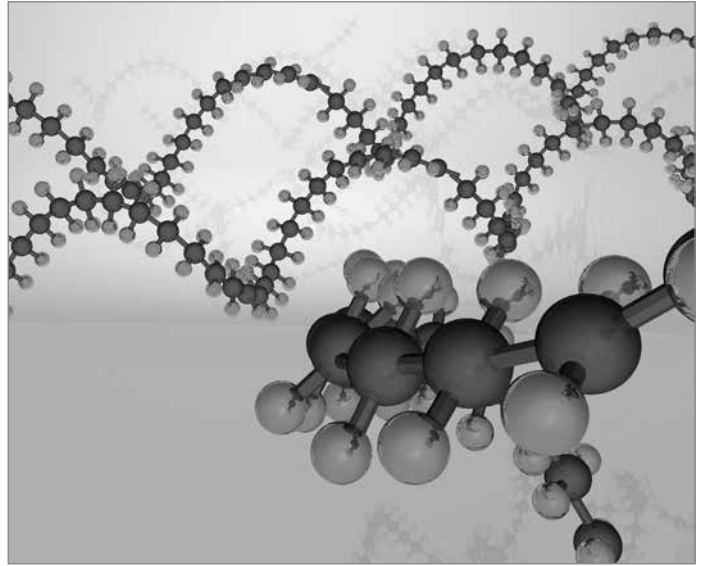

Unlinked PE molecules

The cross-linked macromolecule on the other hand has a three-dimensional structure. The long polyethylene chains are frictionally connected to one another by fixed connections. This molecule structure gives the cross-linked polyethylene its extraordinary properties. The three-dimensional grid doesn't allow the plastic to melt. This is why cross-linked pipes also cannot be welded.

All TECEflex pipes are electron beam cross-linked polyethylene pipes and have proven their worth for years. They fulfil the requirements of the DVGW for drinking water and gas installation and the requirements of DIN CERTCO for heating installations. A TÜV design type approval exists for use in compressed air installations. The pipes are monitored externally by recognised testing institutes and have the most important European permits and certificates.

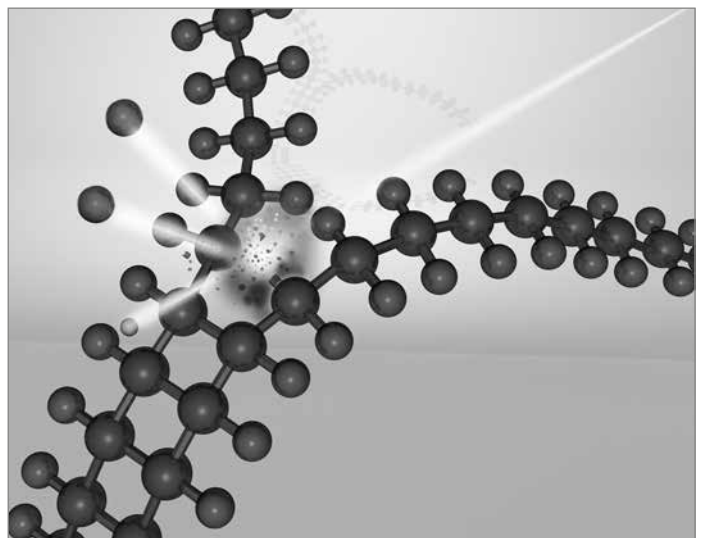

Molecule structure of cross-linked polyethylene

TECEflex pipes are cross-linked using a high energy electron beam. This method is a purely physical process. Pipes

cross-linked via electron beam are marked with PE-Xc. The “PE” stands for the material polyethylene, the “X” for the cross-linking, the index “c” denotes the cross-linking process.

### Memory effect

Cross-linked pipes have a memory effect. This means the plastic tries to return to its original geometry after being deformed. The memory effect makes it possible e.g. to repair kink points in a PE-Xc pipe with an industrial dryer. Unlinked pipes would melt. The memory effect prevents the plastic from flowing under pressure. This constitutes a significant plus in safety for connection technology. The cross-linked plastic of a PE-Xc pipe stays in place even under tension. The memory effect is what makes the O-ring free connection technology of the TECEflex system possible to begin with.

### Benefits of electron beam cross-linked PE-Xc pipes

The increased mechanical load-bearing capacity gives the electron beam cross-linked TECEflex pipes the following properties:

- very good long-term behaviour in internal pressure creep rupture strength tests, even at high temperatures
- good thermal ageing stability so no damage from thermo-oxidative ageing is to be expected during proper use
- high resilience to the formation of stress fractures
- good chemical resistance, meaning also resistant to heating water additions, such as e.g. inhibitors
- can be cold-laid without heat treatment
- laying with tight bending radii
- high corrosion resistance
- smooth pipe walls, which means reduced pressure loss and reduced tendency towards encrustation
- good abrasion resistance and tear resistance
- impact-resistant at low temperatures
- no plastic creep behaviour
- suitable for any quality of drinking water as per the Drinking Water Ordinance (TrinkwV 2001)
- neutral odour and taste
- construction-site quality suitable for harsh everyday installation conditions

## TECEflex composite pipe PE-Xc/Al/PE-RT

The TECEflex composite pipe is equipped with an especially strong inner pipe made of PE-Xc. This inliner alone would fulfil the requirements for pressure and temperature resilience by itself. The aluminium layer and the PE outer layer confer additional mechanical security. The TECEflex composite pipe’s special construction gives it its unique resistance to buckling so that the pipe can be bent and handled by hand without bending springs. Only the yellow composite pipes may be used for gas installation. The pipes are marked with W/G 100. Approved for indoor gas installations up to 100 mbar.

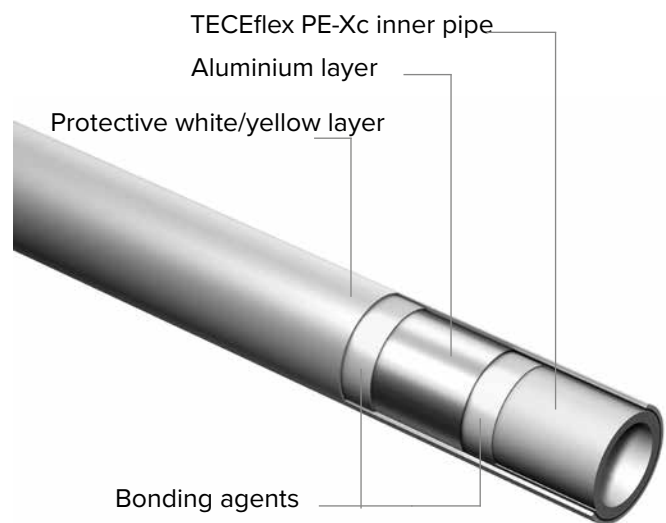

Composition of the TECEflex composite pipe

The PE-Xc/AL/PE-RT composite pipe is a pipe with a butt-welded aluminium layer. This combination of materials reduces the thermal length change and simultaneously makes the pipe rigid and bend-resistant.

TECEflex composite pipes can be used as follows:

- in floor and flat distribution
- in cellars, rising pipes and surface-mounting
- in insulation in concealed areas
- in the connection of radiators, including from the skirting board
- as underfloor and wall heating, etc.

Delivery forms:

- Dimensions from 14–63 (14/16/20/25/32/40/50/63)
- as rolls or in rod form
- in corrugated sheath pipe or
- as pre-insulated variants
- coloured yellow for gas installation

Advantages of TECEflex composite pipe:

- universal pipe for sanitation, heating, compressed air and gas = one pipe for all application areas

## TECEflex - System Description

- linear extension comparable to a metal pipe
- visually appealing white or yellow outer layer
- easy to lay because of its bend-resistant rigidity
- corrosion resistant
- resistant to heating inhibitors
- external and internal monitoring
- outstanding creep strength
- DVGW, TÜV and DIN CERTCO certified
- suitable for drinking water installations according to application class 2 and 10 bar as per ISO 10508 for hot water applications\*
- suitable for heating installations according to application class 5 and 10 bar as per ISO 10508 for high temperature applications\*

### TECEflex PE-Xc 5S pipe

The TECEflex 5S all-plastic pipes are fitted with an internal diffusion block. They are therefore ideally protected against adverse construction site conditions. As a result of the position of the oxygen barrier layer in the middle of the pipe wall, the TECEflex 5S-pipes are insensitive to external humidity, such as condensation water.

The silver PE-Xc 5S pipes can be used for drinking water, heating and compressed air installations.

PE-Xc pipes have enjoyed over 25 years of use in housing technology applications. They stand out in particular on account of their high pressure, temperature and corrosion resistance. The patented TECEflex pressure sleeve technology permits connection without O-rings while allowing for large inner diameters.

The TECEflex PE-Xc 5S pipes may not be used in gas installations.

Delivery forms:

- dimension 16 and 20
- as a roll
- in black corrugated pipe sheathing

Advantages of the TECEflex 5S pipe:

- extremely flexible
- oxygen barrier layer effectively protected by five-layer technology
- oxygen tight to DIN 4726
- external and internal monitoring
- suitable for drinking water installations according to application class 2 and 10 bar as per ISO 10508 for hot water applications\*
- suitable for heating installations according to application class 5 and 6 bar as per ISO 10508 for high temperature applications\*

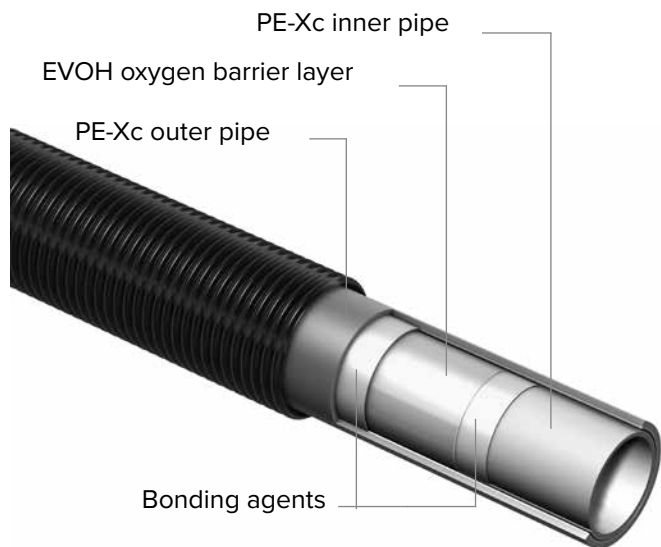

Composition of the TECEflex PE-Xc 5S pipe

### TECEflex PE-MDXc 5S underfloor heating pipe

The PE-MDXc 5S underfloor heating pipe - in accordance with DIN 16894/95 - is a new development in PE-Xc pipes, featuring special characteristics for use in floor heating systems. Like a PE-Xc pipe, this pipe is designed with electron beam crosslinking, but the use of MD-PE gives the pipe increased flexibility. PE-MDXc heating pipes are designed with five-layer technology. The oxygen barrier is located in the middle of the pipe sheath, providing effective damage protection.

Field of application:

Floor heating and radiator installations

Delivery forms:

- dimension 16
- as 200 and 600 m rolls

Advantages of the TECEflex 5S pipe:

- extremely flexible
- oxygen barrier layer effectively protected by five-layer technology
- oxygen tight to DIN 4724
- external and internal monitoring
- suitable for heating installations according to application class 5 and 4 bar as per ISO 10508 for high temperature applications\*

## Fittings

The TECEflex system offers fittings in three material quality grades. All fittings are suitable for TECEflex aluminium composite pipes as well as for all-plastic pipes.

Properties and features of TECEflex fittings:

- same fittings for all TECEflex composite pipes as well as TECEflex PE-Xc pipes
- no sensitive O-rings or additional sealing rings
- clear cross-section
- fittings comply with DVGW worksheet W 534
- national and international certificates

### Red brass



Universal and future-proof – approved for drinking water installations.

The flow-optimised all-round fitting is dimensionally stable and resistant to erosion as well as corrosion through dezincification and stress corrosion cracking. The standardised material complies with generally accepted engineering standards and is recommended by the German Federal Environment Agency (UBA) for drinking water installations. The fitting is ideal for drinking water installations to DIN 1988/DIN EN 806, for gas installations to DVGW TRGI 2008 and TRF 2012, for heating installations and for compressed air installations.

### PPSU



The low-cost alternative to metal fittings. The fitting made of high-performance plastic PPSU is corrosion-free and impact-resistant. It is equally suitable for drinking water

installations to DIN 1988/DIN EN 806 and heating and compressed air installations.

### Brass\*



The inexpensive metallic alternative to red brass fittings made of standard brass. The fitting can be used without restriction for heating and compressed air installations and with certain limitations for drinking water installations. It is also suitable for gas installations to DVGW TRGI 2008 and TRF 2012.

The 98/83 Directive on water quality for human consumption set out by the European Community defines a maximum lead content of 0.01 mg/l. Of this, the maximum amount permitted to emanate from the drinking water installation is 0.005 mg/l.

To ensure reliable compliance with the limit value, TECE recommends using red brass, standard brass or PPSU fittings. These three materials are included on the positive list of the German Federal Environment Agency (UBA).

\* Please note that some qualities of drinking water may have a corrosive effect on metals. We recommend checking the selection of the material (see technical data section of the tube and the chart on following pages).

# TECEflex - System Description

## Pressure sleeves

The TECEflex composite pipes and TECEflex PE-Xc pipes are pressed using various pressure sleeves.

- brass-coloured pressure sleeves for TECEflex composite pipes
- silver-coloured pressure sleeves for TECEflex PE-Xc or PE-MDXc 5S pipes

## TECEflex system application limits

- suitable for drinking water installations according to application class 2 and 10 bar as per ISO 10508 for hot water applications
- suitable for heating installations according to application class 5 and 10 bar as per ISO 10508 for high temperature applications
- local legislation, standards and guidelines should be observed for gas and liquid gas installations.

The system can be operated at 95 °C for a short time but the TECEflex components may not be subjected to a temperature greater than 100 °C at any time. Open flames are not permitted. With soldered connections on copper pipe, the solder connection must be established first. With the TECEflex system pipe connection, you must wait until the fitting has cooled down.



| TECEflex system pipes   | Multi-layer composite pipes |                            |            |                    |      |      |      |      |
|---|-----------------------------|----------------------------|------------|--------------------|------|------|------|------|
| Pipe designation  | PE-Xc/AL/PE                 |                            |            |                    |      |      |      |      |
| Dimension   | 14                          | 16                         | 20         | 25                 | 32   | 40   | 50   | 63   |
| Delivery length – roll in m   | 120                         | 100                        | 100        | 50                 | -    | -    | -    | -    |
| Rods (m) (5 m/pipe)   | -                           | 100                        | 70         | 45                 | 30   | 15   | 15   | 5    |
| Field of application*   | HKA, FBH,<br>DLA            | TWA, HKA, FBH,<br>DLA, GAS |            | TWA, HKA, DLA, GAS |      |      |      |      |
| Application class/ operating pressure   | 2 / 10 bar<br>5 / 10 bar    |                            |            |                    |      |      |      |      |
| Colour  | white                       | white<br>yellow            |            |                    |      |      |      |      |
| Outside diameter in mm  | 15                          | 17                         | 21         | 26                 | 32   | 40   | 50   | 63   |
| Wall thickness in mm  | 2.60                        | 2.75                       | 3.45       | 4.00               | 4.00 | 4.00 | 4.50 | 6.00 |
| Inside diameter in mm   | 9.8                         | 11.5                       | 14.1       | 18                 | 24   | 32   | 41   | 51   |
| Available in corrugated protective pipe                                       | yes                         |                            |            |                    | -    |      |      |      |
| Deliverable with insulation<br>$\lambda = 0.040 \text{ W/(m} \cdot \text{K)}$ |                             |                            |            |                    |      |      |      |      |
| - 6 mm  | --                          |                            | yes        |                    |      |      | --   |      |
| - 9 mm  | --                          |                            | yes        |                    |      |      | --   |      |
| - 13 mm   | --                          |                            | yes        |                    |      |      | --   |      |
| Pipe weight empty in kg/m   | 0.11                        | 0.14                       | 0.21       | 0.30               | 0.40 | 0.53 | 0.80 | 1.29 |
| Internal volume in dm <sup>3</sup> /m   | 0.08                        | 0.10                       | 0.16       | 0.25               | 0.45 | 0.80 | 1.32 | 2.04 |
| Pipe roughness in mm  | 0.007                       |                            |            |                    |      |      |      |      |
| Thermal conductivity uninsulated<br>in W/(m <sup>2</sup> K)                   | 0.35                        |                            |            |                    |      |      |      |      |
| Coefficient of thermal expansion<br>in mm/(mK)                                | 0.026                       |                            |            |                    |      |      |      |      |
| Minimum bending radius in mm<br>(5 x dimension)                               | 70                          | 80                         | 100 (80)** | 125                | 160  | 200  | 250  | 315  |

\* TWA - drinking water systems; HKA - radiator connection; FBH - floor heating; DLA - compressed air systems; GAS - gas installations

The classification of the application classes corresponds to the information in ISO 10508[4].

\*\* Pipes of dimension 20 can also be bent with 4 times the dimension.

Technical pipe data TECEflex – Part 1

# TECEflex - System Description

| TECEflex system pipes   | PE-MDXc 5S heating pipes<br>in accordance with DIN 4724 |         | PE-Xc 5S heating pipes<br>in accordance with DIN EN ISO 15875 |      |
|---|---|---------|---|------|
| Pipe designation  | PE-MDXc 5S  |         | PE-Xc   |      |
| Dimension   | 16  | 20      | 16  | 20   |
| Delivery length – roll in m   | 200/600   | 200/600 | 200   | 120  |
| Rods (m) (5 m/pipe)   | -   | -       | -   | -    |
| Field of application*   | FBH, HKA  |         | FBH, HKA  |      |
| Application class/ operating pressure   | 5 / 4 bar   |         | 2 / 10 bar<br>5 / 6 bar                                       |      |
| Colour  | mother of pearl   |         | silver  |      |
| Outside diameter in mm  | 16.2  | 20      | 16  | 20   |
| Wall thickness in mm  | 2.0   | 2.8     | 2.2   | 2.8  |
| Inside diameter in mm   | 12  | 14.4    | 11.6  | 14.4 |
| Available in corrugated protective pipe   | -   | -       | yes   | yes  |
| Deliverable with insulation<br>$\lambda = 0.040 \text{ W}/(\text{m} \cdot \text{K})$<br>- 6 mm<br>- 9 mm<br>- 13 mm | --<br>--<br>--  |         | --<br>--<br>--  |      |
| Pipe weight empty in kg/m   | 0.08  | 0.14    | 0.09  | 0.14 |
| Internal volume in dm <sup>3</sup> /m   | 0.11  | 0.16    | 0.11  | 0.16 |
| Pipe roughness in mm  | 0.007   |         | 0.007   |      |
| Thermal conductivity uninsulated in W/(m <sup>2</sup> K)  | 0.35  |         | 0.35  |      |
| Coefficient of thermal expansion in mm/(mK)   | 0.2   |         | 0.2   |      |
| Minimum bending radius in mm (5 x dimension)  | 80  | 100     | 80  | 100  |

\* TWA - drinking water systems; HKA - radiator connection; FBH - floor heating; DLA - compressed air systems  
The classification of the application classes corresponds to the information in ISO 10508[4].

## Technical pipe data TECEflex – Part 2

### Operating parameters

If the operating parameters are exceeded then the pipes and connections will be overstressed. The operating parameters must therefore not be exceeded. This should be ensured using suitable safety/regulation devices (e.g. pressure regulators, safety valves or similar).

| Application class | Calculation temperature $T_D$<br>°C | Operating period <sup>b</sup> with $T_D$<br>Years <sup>a</sup> | $T_{max}$<br>°C | Operating period with $T_{max}$<br>Years | $T_{mal}$<br>°C | Operating period with $T_{mal}$<br>Hours | Typical application area                                 |
|-------------------|-------------------------------------|--|-----------------|--|-----------------|--|--|
| 1 <sup>a</sup>    | 60                                  | 49   | 80              | 1  | 95              | 100                                      | Hot water supply (60 °C)                                 |
| 2 <sup>a</sup>    | 70                                  | 49   | 80              | 1  | 95              | 100                                      | Hot water supply (70 °C)                                 |
| 3 <sup>c</sup>    | 20                                  | 0.5  | 50              | 4.5                                      | 65              | 100                                      | Low-temperature floor heating                            |
|                   | 30                                  | 20   |                 |  |                 |  |  |
|                   | 40                                  | 25   |                 |  |                 |  |  |
| 4 <sup>b</sup>    | 20                                  | 2.5  | 70              | 2.5                                      | 100             | 100                                      | Floor heating and<br>low-temperature radiator connection |
|                   | 40                                  | 20   |                 |  |                 |  |  |
|                   | 60                                  | 25   |                 |  |                 |  |  |
| 5 <sup>b</sup>    | 20                                  | 14   | 90              | 1  | 100             | 100                                      | High-temperature radiator connection                     |
|                   | 60                                  | 25   |                 |  |                 |  |  |
|                   | 80                                  | 10   |                 |  |                 |  |  |

$T_D$  = temperature the pipe system is designed for.  $T_{max}$  = maximum temperature permitted for a short time.

$T_{mal}$  = highest possible temperature that may be reached in the event of the fault "mal" (maximum 100 hours in 50 years).

<sup>a</sup> A state can select either class 1 or class 2 according to its national provisions.

<sup>b</sup> If there is more than one operating temperature for the operating duration and the associated temperature for an application class, the corresponding operating duration times should be added. "Plus cumulative" in the table implies a temperature group for the temperature given for an operating period (e.g. the temperature group for a period of 50 years for class 5 is made up as follows: 20 °C over 14 years, followed by 60 °C over 25 years, followed by 80 °C over 10 years, followed by 90 °C over 1 year, followed by 100 °C over 100 h).

<sup>c</sup> Only permitted if the fault temperature cannot exceed 65 °C.

Application classes and classification of operating conditions in accordance with ISO 10508

## Areas of application

### Drinking water installation

Drinking water presents special requirements for an installation system. It's a consumable and must not be negatively impacted by the installation system materials. The planning and design as well as the operation of drinking water installations must be carried out in accordance with DIN 1988, DIN EN 806, DIN EN 1717/A1 and VDI 6023. The fitter has to make sure that they are installing a piping system that corresponds to the applicable recognised technical regulations. The TECEflex system is DVGW certified and proven suitable for drinking water installations. Among other things, the DVGW certification includes:

- technical inspection of the components
- KTW inspection
- Certification in accordance with worksheet DVGW W270

### Field of application

The TECEflex system is suitable for all drinking water qualities in accordance with DIN 50930 Section 6, which comply with the current Drinking Water Ordinance (TrinkwV 2011), DIN 2000 and EU Council Directive 98/83/EG dated 3rd November 1998.

The following components are available for drinking water installations:

- plastic fittings made of PPSU
- flow-optimised metal fittings made of red brass
- Composite pipes with PE-Xc inliners
- All-plastic pipes made of PE-Xc

All materials are recommended by DVGW and recognised across Europe. All metallic components in the TECEflex that come into contact with water comply with the evaluation principles (as at 19/01/2016) of the German Federal Environment Agency (UBA) as per the 4MS material list (as at 05/01/2017).

### Material selection

The fitter has satisfied their duty of care when they

- have presented the drinking water analysis as per DIN 50930-6 for the supply area of the building project to be constructed and have inspected the suitability of the TECEflex system,
- have satisfied themselves of the supplier's experience,
- if necessary, receive approval for TECEflex from TECE.

### Measures for Legionella prophylaxis

Drinking water installations must be planned, designed and operated with special care in accordance with DIN EN 806 and DIN 1988; VDI 6023 and DVGW worksheet W551 also apply.

The risk of Legionella formation can be minimised by complying with a few simple rules:

- Unnecessary and dead pipe sections where water can stagnate should be immediately disconnected at the outlet.
- Care should be taken during installation to ensure no dirt is introduced into the piping system
- the storage water volume should be designed to be as small as possible.
- Pipes should be selected in the correct dimensions.
- Circulation pipes must not be designed to be too large.
- Circulation pipes must be hydraulically balanced.
- The temperature of the hot water boiler must be at least 60°C.
- The circulation return must not fall below 55 °C.
- The system should be rinsed particularly thoroughly during commissioning.
- No organic materials such as e.g. hemp should remain in the drinking water installation.
- Uninsulated sections of the hot water line should be avoided.
- Care should be taken to ensure the correct function and maintenance of water treatment systems and filters.
- A local hot water supply should be installed if tapping points are far away or used very rarely.
- If cold water lines are located next to hot water lines or heating pipes, they have to be insulated well, so that the cold water cannot heat up.
- Lines carrying cold water should not be laid in hollow spaces in which circulation and heating lines are located.
- For hygiene reasons, pressure tests should not be performed with water but rather oil-free compressed air or inert gas. Pressure tests with water are only permitted immediately prior to the commissioning of the installation. Only drinking water with no hygiene issues should be used for rinsing and the pressure test.

# TECEflex - Areas of application

## Disinfection of drinking water installations

The suitability of the TECEflex system for drinking water is confirmed by the DVGW certification. The components of the TECEflex system are made from materials recognised and valued across Europe. A drinking water installation planned, designed and operated in accordance with DIN 1988, DIN EN 806, DIN EN 1717/A1 and VDI 6023 has no hygiene issues and in principle requires no disinfection measures. Disinfection is only necessary in exceptional instances and only then to be carried out if there is an urgent requirement (contamination).

This is to be viewed as an immediate emergency measure in order to return the drinking water installation to a usable state. The cause of the microbial contamination - e.g. construction fault or incorrect operation - must be eliminated. The maintenance of the usability of the drinking water installation by repeated disinfection measures must be avoided. In such instances, remodelling works take priority over disinfection measures. Repeated courses of disinfection have a negative impact on the service life of the installation.

A fundamental distinction is to be made between measures outside of ongoing operation (chemical disinfection) and measures in ongoing operation (thermal disinfection and continuous chemical disinfection).

### Thermal disinfection

DVGW worksheet W551 prescribes a three-minute flushing of each tapping point with hot water at a minimum temperature of 70° C. It has been proven in practice that the hot water boiler should be heated to 80 °C to compensate for the temperature losses to the tapping points. Before rinsing the tapping points any existing circulation (if present) must be switched on until the circulation line reaches a minimum of 70 °C. Check that no users could scald themselves during the thermal disinfection. All drinking water installation pipes from the TECEflex system can be promptly disinfected using this method. Restriction of the service life of the TECEflex pipes cannot be ruled out where thermal disinfection is used regularly and consideration should be given to renovation of the drinking water installation.

### Chemical disinfection

Chemical disinfection measures should be carried out in compliance with DVGW worksheet W 291. Care should be taken that the active ingredients, concentrations, usage periods and maximum temperatures listed here are complied with. The combination of thermal and chemical disinfection is not permitted. The water temperature during chemical disinfection must not exceed 25 °C.

The TECEflex system can be disinfected using the disinfection agents listed in DVGW worksheet W 551. The dosages must not be exceeded. It should be ensured that nobody draws drinking water during the disinfection process. Following chemical disinfection it **MUST** be ensured that all disinfection agent residues have been sufficiently rinsed out of the piping network. The water containing the disinfection agent must not be added to the drainage.

Prior to carrying out disinfection measures with chemical agents it should be ensured that all components of the drinking water installation are resistant to the agent. Special attention should be given to stainless steel components. The provisions of DVGW worksheet W 551 must be observed. The manufacturer of the disinfection agent must approve the suitability of the agent for use with PE-Xc pipes and red brass. The manufacturer's specifications must be observed.

The disinfectant effect of the chemical disinfection agent normally results from the oxidative effect of the contents. Regular disinfection means the materials that comprise the drinking water installation could also be attacked. Repeated courses of chemical disinfection have a significant negative impact on the service life of the TECEflex system. The total number should thus be restricted to five disinfection cycles over the total service life of the pipes. Repeated disinfection measures do not conform to the state of the technology. A disinfection measure is only warranted in order to return a drinking water installation to a usable state following contamination.

| Agent   | Form of delivery  | Storage  | General safety information *   | Max. concentration                     | Effect duration | Maximum temperature permitted |
|---|---|--|--|--|-----------------|-------------------------------|
| Hydrogen peroxide H <sub>2</sub> O <sub>2</sub> | Watery solution in various concentrations                 | Away from light, cool, avoid all contamination         | Protective gear required for solutions >5%                                     | 150 mg/l H <sub>2</sub> O <sub>2</sub> | Max. 24 h       | T <sub>max</sub> ≤ 25 °C      |
| Sodium hypochlorite                             | Watery solution with maximum 150 g/l chlorine             | Away from light, cool, sealed and in a collection tray | Alkaline, irritant, poisonous, protective gear required                        | 50 mg/l chlorine                       | Max. 12 h       | T <sub>max</sub> ≤ 25 °C      |
| Chlorine dioxide ClO <sub>2</sub>               | Two components: sodium chlorite, sodium peroxide sulphate | Away from light, cool and sealed                       | Oxidative effect, do not inhale chlorine dioxide has, protective gear required | 6 mg/l ClO <sub>2</sub>                | Max. 12 h       | T <sub>max</sub> ≤ 25 °C      |

\* The corresponding notes in the manufacturer's safety datasheets must be observed.

\*\* This value must not be exceeded over the total usage period at any point in the installation.

Chemical disinfections, agents and concentrations in accordance with e.g. DVGW W 557

### Continuous chemical disinfection

Disinfection of a contaminated drinking water system over a constant given dose of disinfection agents is not expedient according to today's knowledge. It should therefore only be carried out in rare exceptional cases. Here it should be ensured that the requirements of the current Drinking Water Ordinance and the UBA list in accordance with Sec. 11 DWO (TVO) are met. The prescribed limit values would have to be exceeded significantly in order to achieve a relevant effect, however. Continuously added disinfection agents can have a significant effect on the service life of the drinking water installation. This kind of disinfection is advised against due to possible material deterioration. No guarantee can be made in these cases.

### Heating installation

The following components are available for heating installations:

- plastic fittings made of PPSU
- Metal fittings made of brass or red brass
- Composite pipes with PE-Xc inliners
- 5S all-plastic pipes made of PE-Xc
- 5S all-plastic pipes made of PE-MDXc

All materials are oxygen tight to DIN 4724/4726.

### Compressed air installation

TECEflex moulded and connection parts as well as TECEflex aluminium pipes are suitable for use in compressed air systems. The same fittings and pipes are used in compressed air installations as in drinking water and heating installations.

TECEflex is certified by TÜV Süd as a compressed air system and has the right to display the TÜV seal. This certification also includes TECEflex PPSU fittings.

System-wide connections with armatures, valves, fittings, etc. can be established using TECEflex threaded fittings. The TECEflex is suitable for compressed air with these parameters

- Nominal pressure 16 bar
- Operating pressure 12 bar and
- Maximum peak operating temperature 60° C.

The TÜV Süd certificate is available for download at [www.tece.de](http://www.tece.de).

# TECEflex - Connection technology

## Connection technology

The patented TECEflex pressure sleeve connection is a specially approved connection technique that has been tried and tested for years in sanitary and heating installation. The functional safety is i.a. evidenced by the DVGW system registration DW8501 AQ2007.

### Axial pressing technology

TECEflex connections are based on axial pressing technology. Here a pressure sleeve is slid axially over an expanded pipe and the fitting. Since the fittings are inserted into an expanded pipe, they have a larger internal diameter compared to plastic pipe connector sealed with O-rings and are characterised by especially low pressure loss. The sealing effect is achieved solely by the pressing of the full pipe material surface against the fitting. This is why TECEflex fittings don't need O-rings. This thus rules out faults like the ones that occur when working with O-rings. There's no gap or clearance for water to get into and stagnate in. This is especially relevant because stagnating water represents a significant hygiene risk.



Depiction of a TECEflex connection:

1. Unpressed connections can be recognised easily due to loosely attached pressure sleeve
2. Unpressed connections become wet during the pressure test
3. Pressure sleeve at the front, connection tight! The condition of the pressing tools has no impact on the tightness of the connection.

## Forced leakage

The TECEflex connection technology fulfils the requirements of DVGW worksheet W 534, paragraph 12.14 of connectors with forced leakage. This means that an unpressed TECEflex connection is easily recognisable by the water coming from it during the pressure test. Additionally, the status of the press seal is visibly clear by the pressure sleeve loosely seated on the pipe and clearly unpressed.

The controlled leakage is tested and certified by DVGW. The DVWG certificate is available for download at [www.tece.de](http://www.tece.de).

## Installation information

The TECEflex system must be processed only with the accompanying system tools. It is not permitted to connect TECEflex components with third-party pipes or fittings. A warranty claim can only be made for the possible applications outlined in the System Description.

### Connection with TECEflex manual tools

TECEflex connections up to dimension 32 can be connected using the TECEflex hand tools.



TECEflex manual tools: Expanding tool with expansion head, pipe cutting pliers, handheld crimping pliers with fork heads (from left)

The following work steps must be performed to ensure a correct TECEflex connection:

#### Step 1 – Shorten pipe:



Cut the installation pipe at a right-angle with the TECE pipe cutting pliers (order no.: 8760002 or 720093). It is recommended that the plastic pipe cutters be used for dimension 32 and up (order no.: 8760008).

**Note:** TECEflex pipes may only be processed using cutting tools in perfect condition. The cutters in particular must be sharp and free of burrs otherwise the installation pipe could be damaged during expansion.

#### Step 2 - Slide on pressure sleeve:



Slide the TECEflex pressure sleeve over the end of the pipe. Here the flat side of the collet (without outer ring) must face the fitting.

#### Step 3 – Expand pipe:

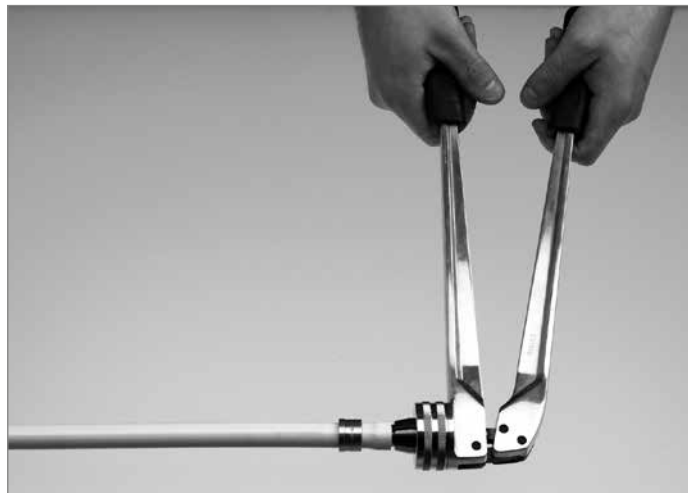

Select the expansion head to match the dimension of the pipe and screw on the expanding tool (order no.: 720056). Slide the end of the pipe onto the expansion head up to the stopper and expand. The TECEflex composite pipes may only be expanded once!

## TECEflex - Installation information

### Step 4 – Slide on pipe:



The TECEflex installation pipe must be slid onto the fitting up to the last saw tooth. The pipe does not need to be pushed up to the stopper, the appropriate depth is already set by the expansion. It is not necessary to mark the insertion depth.

### Step 5 – Create connection:

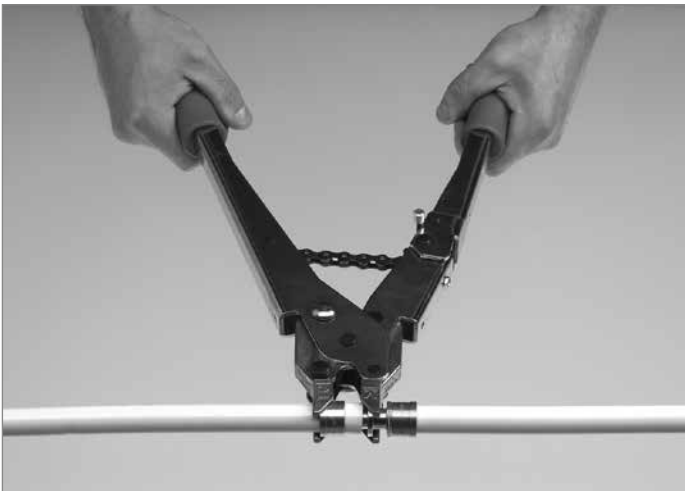

Select the fork heads labelled with the pipe dimension and attach them to the handheld crimping pliers using the bolt (order no.: 720050). Push the pressure sleeve towards the end of the pipe by hand as far as it will go, insert the fitting and sleeve into the fork heads. Squeeze the handheld crimping pliers repeatedly to press the pressure sleeve up to the fitting. A remaining gap of approx. 0.5 mm between the fitting and the sleeve is specific to the production and insignificant. The connection is even then perfect if the pipe is not slid up to the pressing collar of the fitting.

**Note:** Pay attention to the correct positioning of the pressing tool when pressing. The fitting must be seated in the pressing tool fully and a right-angle to avoid damage to the fitting collar.

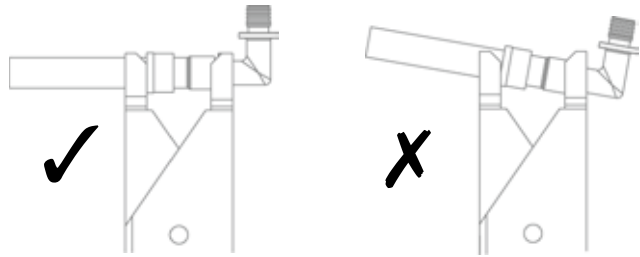

Pressing: Correct position (on left) – Incorrect position (on right)

### Connection with RazFaz battery-powered tool

The RazFaz tools - one pressing tool and one expansion tool - let you create TECEflex connections up to dimension 32. The light and handy battery-powered tools enable rational working even in narrow mounting situations or pressing directly on the wall.



TECEflex RazFaz battery-operated tools: Expansion tool with expansion heads and pressing tool with pressing forks

The working steps required for a correct connection correspond to the process for "Connection with TECEflex manual tools" (see previous section). Only the expansion (step 3) and pressing (step 5) are carried out with the RazFaz tools.

### Step 3 – Expand pipe:

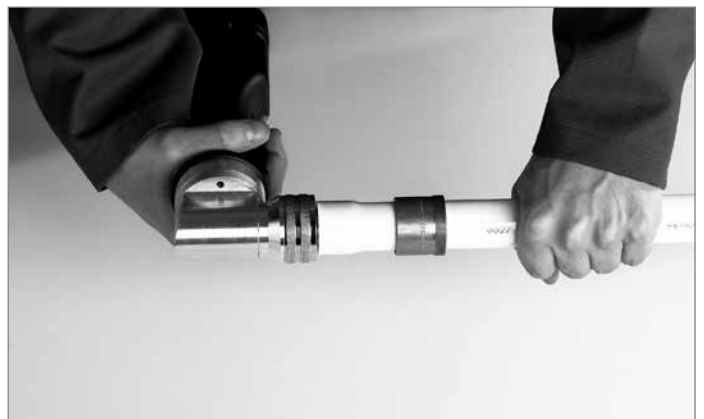

Select the expansion head matching the pipe dimension and screw it onto the RazFaz expansion tool. Now slide the expansion head into the pipe up to the stopper and carry



out the expansion with the pressing tool. The tool must be held right in front of the end of the pipe.

The tool has a final check, which means that the expansion process has to be performed as long as it takes until the expansion head automatically returns to the starting position.

#### Step 5 – Create connection:

Slide the matching pressing forks onto the pressing tool and lock in with the safety pins. The forks are designed for two dimensions each (14/16–20 and 25–32) and come with seamless 360° rotation.

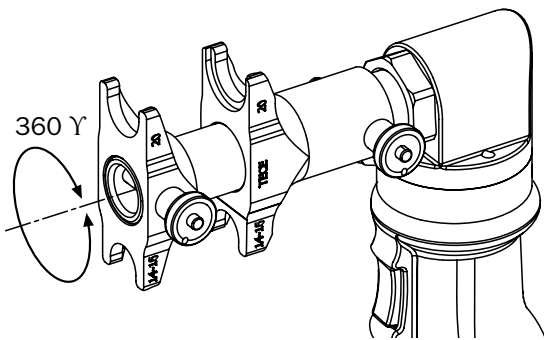

Slide the pressure sleeve up to the end of the pipe as far as possible and place the pressing forks straight on the fitting.

Squeeze the pressing tool to slide the pressure sleeve up to the fitting.

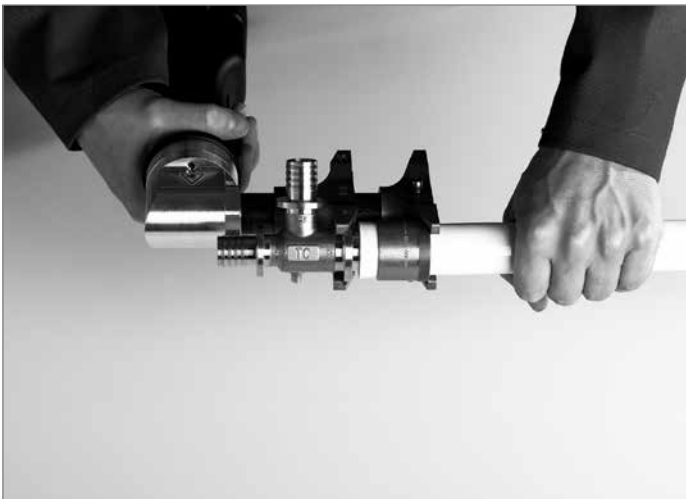

The pressing tool also has a final check, which means that the pressing process has to be performed as long as it takes until the pressing forks automatically return to the starting position.

Special care should be taken when pressing PPSU fittings. The pressing forks must always be seated correctly. The tool must not be used diagonally.

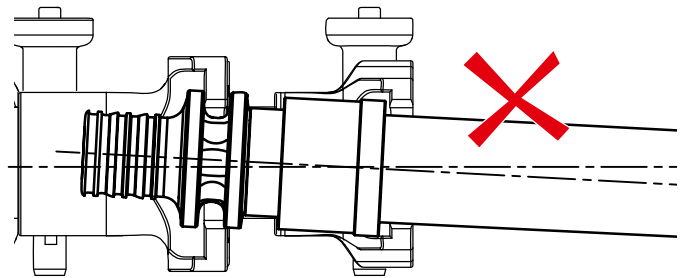
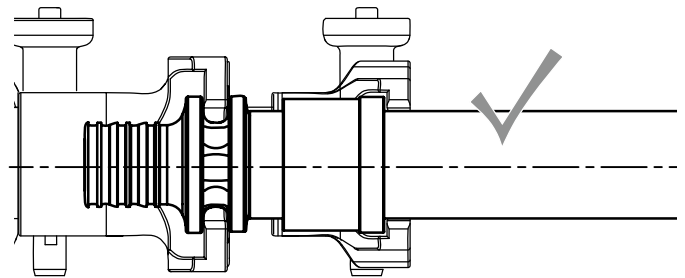

The RazFaz tools are high-quality and technically sophisticated hydraulic units. The quality of the TECEflex connection does not depend on the maintenance status of the RazFaz devices. It is still recommended, however, that the devices are maintained on a regular basis. You can find a service address at:

#### **Novopress GmbH & Co. KG**

Scharnhorststraße 1

41460 Neuss

Germany

[info@novopress.de](mailto:info@novopress.de)

## TECEflex - Installation information

### Connection with pressing tool PMA

The TECEflex tools for working with dimensions 40–63 require a drive in the form of a commercial pressing machine with a pressing force of at least 32 kN, whereby the pressing force **may not exceed 34 kN**. Damage to the tool cannot be ruled out where higher pressing forces are applied.

TECE recommends the following pressing machines:

| Manufacturer<br>(system operator)   | Machine type  |
|-------------------------------------|---|
| KLAUKE<br>(Uponor)                  | UAP1 (UP63, UP75); UAP2<br>UAP3L; UAP4L<br>UNP2<br>HPU2<br>UP2EL (UP50EL)<br>UP2EL14 (UP50EL) |
| NOVOPRESS<br>(Mapress)<br>(Geberit) | EFP 2<br>EFP; ECO1; ACO1<br>ACO 201; ECO 201<br>ACO 202; ECO 202<br>AFP 202; EFP 202          |
| NUSSBAUM (Viega)                    | Type 1; Type 2<br>Type 3; Type 4<br>Type 5; Type 5a<br>Presshandy (battery)<br>Picco          |
| REMS/ROLLER                         | Battery press   |
| ROTHENBERGER                        | Romax Pressliner (Eco)<br>Romax 3000<br>Romax AC Eco  |
| GEBERIT                             | PWH 75  |

In the event that a pressing machine cannot be found in the list below, approval should be sought from TECE.

**Note:** A connection is correctly pressed when the pressure sleeve is slid up to the fitting. The guarantee for the press connection therefore does not depend on the status of the pressing tool - the position of the pressure sleeve is the crucial factor.

Please read the manufacturer's safety information for the pressing machine and the TECEflex tools before use and observe these during use.

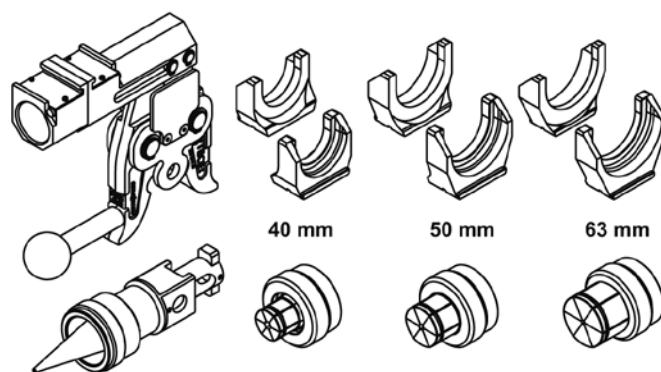

Pressing tool PMA 40 63 TECEflex

The working steps required to form a connection - using the toolset - are analogous to those for using the handheld pressing tools.



The pipe is disconnected with a pipe cutter (order no. 8760008). The pipe cutter is fitted with a special plastic pipe cutting wheel.

**Note:** TECEflex pipes may only be processed using cutting tools in perfect condition. The cutters in particular must be sharp and free of burrs otherwise the installation pipe could be damaged during expansion.



In the second step, the TECEflex pressure sleeve is slid over the end of the pipe. Here the flat side of the collet (without outer ring) must face the fitting.

**Note:** Only perform tool changes on an unpowered pressing machine!

Select the expansion tool matching the dimension, insert it into the pressing machine and lock in with the safety bolt. Slide the end of the pipe onto the expansion head up to the stopper and perform the expansion at the pressing machine. The tool must be held straight and right in front of the end of the pipe.

The pipe must be slid onto the fitting up to the last saw tooth. The pipe does not need to be pushed up to the stopper, the appropriate depth is already set by the expansion.

The connection is created in the next step: Insert the pressing machine attachment PMA - with the pressing forks to match the pipe dimension - into the recess on the pressing machine and lock into the place with the safety bolts.

Push the pressure sleeve towards the end of the pipe by hand as far as it will go, insert the fitting and place the pressure sleeve straight between the fork heads. The base body of the sliding jaw must point parallel to the pipe. Squeeze the pressing machine to press the pressure sleeve up to the fitting. A remaining gap of approx. 0.5 mm between the fitting and the sleeve is specific to the production and insignificant.

## Reuse of pressed fittings

TECEflex fittings that are already pressed can be reused. The fittings can simply be removed from the pipe by heating the connection up to approx. 180 °C with a hot air dryer.

Please remember the following:

- Only metallic moulded and connection parts can be reused (not PPSU fittings).
- The fitting to be reused must be completely disconnected from the piping system so that the existing installation is not exposed to temperatures above 110 °C. If fittings have multiple outlets (e.g. tees or elbows), all connections must be removed.
- The pressure sleeves may not be reused.
- Allow the fitting to cool down sufficiently.
- Never heat with an open flame!
- Never remove the heated pipe end from the connector with bare hands - always use pliers!



# TECEflex - Installation Guidelines

## Installation Guidelines

For the installation of heating, drinking water, compressed air and gas installations, the applicable technical rulings, standards and provisions should be observed. Installations must only be carried out by specialist companies.

### General notes

The following information should be considered when using TECEflex pipes.

#### Threaded connections

For threaded connections TECE recommends the use of hemp combined with a sealant paste approved for this purpose. Using too much hemp can cause damage to the internal and external threaded components. Care should be taken to ensure no hemp residue remains in the pipe system. If other thread sealants are used, the warranty must be assumed by the sealant manufacturer.

#### Processing temperatures

The TECEflex system can be handled down to a minimum temperature of 0 °C. With lower temperatures, the ends of the pipe should be warmed up until "lukewarm". The use of open flames is also prohibited!

#### Coating of fittings

TECEflex fittings must be fundamentally protected from contact with the wall structure, plasterboard, cement, screed, rapid binders or similar using suitable coverings. Direct contact with the structural shell must be avoided at all costs owing to the sound insulation requirements in accordance with DIN 4109 and VDI 4100.

#### Kinks and deformities

If a TECEflex pipe develops a kink or deformation due to incorrect handling or unfavourable construction site conditions then the site of the deformation must be repaired or an elbow fitting equipped for tight radii.

#### Use with poured asphalt

The high temperatures than can occur with the application of poured asphalt (approx. 250 °C) would destroy the pipeline immediately on direct contact. This also applies to the use of pipe-in-pipe systems. Suitable protection measures should therefore be taken. The pipe-in-pipe lines installed on the bare concrete are sufficiently protected against burning when the insulating fibreboards used during work with poured asphalt are laid over the pipes before the asphalt is applied. What is particularly critical is not the open floor areas, however, but the locations at which the lines are guided from the bare concrete into the wall structure. Here the lines are optimally protected when the edge insulation strips are laid in front of the lines so that

they maintain a certain distance and the space around the lines can be filled in with sand. These protective measures should be checked once again before the poured asphalt is actually applied in order to avoid irreparable damage to the piping system. During the application of the asphalt the pipes should be flushed with cold water.

#### Avoidance of air pockets

Pipes must be laid such that no air pockets can form. At the deepest point in the system there must also be a facility for draining the pipeline.

#### Protection against UV radiation

UV radiation damages the TECEflex pipes over longer periods of time. The pipe packaging offers sufficient protection against UV radiation but is not weather-proof. The pipes should therefore not be stored out in the open. The pipes should not be exposed to sunlight for unnecessary amounts of time. They should be protected against UV light where necessary. TECEflex pipes laid in the open must be protected against sunlight in a black corrugated pipe.

#### Identification of pipelines

TECE recommends identifying installation pipes in accordance with DIN 2403.

#### Installing TECEflex in soil

Pipes from TECEflex can be installed in soil under the following conditions:

- The pipelines must be installed in a sand bed.
- The pipelines must be covered in enough fine-grained sand that there is no risk of damage to the pipe from the later application of the filling material.
- Pipelines laid in soil must not be affected by traffic loads.
- The fittings and the pressure sleeves must be protected from direct contact with soil using suitable anti-corrosion agents.
- Wall bushings in soil must be suitable for plastic piping and the pipe secured against removal. They must be installed according to the applicable technical rulings and provisions.

### Installation on bitumen sheets

TECEflex pipes must be completely dried before laying these on bitumen sheets or coatings containing solvents. The manufacturer's setting times should be observed.

### Arrangement of pipelines

If cold and hot water pipes are laid on top of one another, the pipes carrying hot water must be laid above the cold water line.

### Contact with solvents

Direct contact between TECEflex components and solvents or solvent-based paints, dyes, sprays, adhesive strips, etc. should be avoided. Solvents can erode the plastic components in the system.

### Potential equalisation

TECEflex composite pipes may not be used as earthing conductors for electrical systems in accordance with VDE 0100.

This means metal pipe installations exchanged in part for a pipe from the TECEflex range (e.g. during renovations) should be checked for correct earthing.

### Protection against frost

Filled TECEflex pipes should be protected against frost. The TECEflex system is suitable for the following frost protection agents and concentrations:

- Ethyl glycol (Antifrogen N): May be used up to a concentration of maximum 50%. TECE recommends restricting the concentration to 35%. A concentration of 50% Antifrogen N corresponds to frost protection down to a temperature of -38 °C. A concentration of 35% Antifrogen N corresponds to frost protection down to -22 °C. If Antifrogen N is dosed above 50%, the frost protection effect is reversed. Slurry ice formed at temperatures below -25 °C.
- Propylene glycol: May be used up to a concentration of maximum 25%. Propylene glycol is primarily used in the foodstuffs industry. A concentration of 25% corresponds to frost protection down to -10 °C. Overdosing with propylene glycol can lead to stress fractures in the pipe material.

### Heat tracings

Heat tracings as well as self-regulating heater bands approved by manufacturers for plastic piping systems can be used for TECEflex. To ensure optimum heat transfer the heating bands are attached to the TECEflex installation pipe across their full surface using broad aluminium adhesive strips. The manufacturer's instructions should be followed.

### Bending radii

The TECEflex composite pipes can be bent in the neutral line with a minimal bending radius - corresponding to 5x the dimension of the pipe.

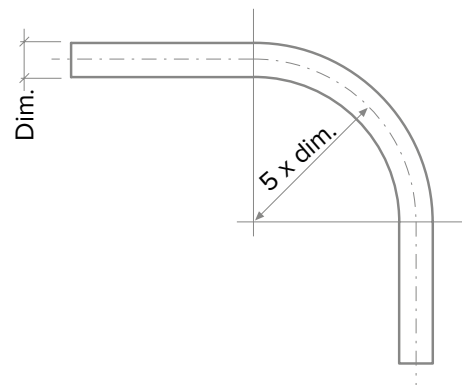

Minimal bending radius of TECEflex composite pipes

#### Note:

No pressings may be used near the bend. In addition, a bend should be made before the pressing that lies directly on the fitting.

TECEflex composite pipes can be bent by hand up to dimension 20. Bending springs are not required. Commercial bending tools can be used from dimension 25.

| TECEflex pipe dimension | Minimum bending radius in mm |
|-------------------------|------------------------------|
| 14                      | 70                           |
| 16                      | 80                           |
| 20                      | 100 (80)*                    |
| 25                      | 125                          |
| 32                      | 160                          |
| 40                      | 200                          |
| 50                      | 250                          |
| 63                      | 315                          |

Bending radii of TECEflex composite pipes

\* Pipes of dimension 20 can also be bent with 4 times the dimension.

# TECEflex - Installation Guidelines

## Thermal length changes

Materials expand when heated and contract when cooling down. The systemic, huge temperature differences mean that the lines in hot water and heating installations must be attached such that the length extension in elbows or special compensating elbows can be balanced out.

### Detecting thermal length changes

Thermal length changes are detected using the following formula:

$$\Delta l = \alpha \cdot l \cdot \Delta t$$

- $\Delta l$  thermal length change of the pipe in mm
- $\alpha$  expansion coefficient of the TECEflex pipes
- $l$  starting length of the pipe in m
- $\Delta t$  temperature difference in K\*

\* K = Kelvin is the SI base unit of temperature and relates to absolute zero.  
(0 °C = 273.16 K)

Extension coefficient of the TECEflex pipes:

Composite pipes  $\alpha = 0.026 \text{ mm}/(\text{mK})$

PE-Xc pipes  $\alpha = 0.2 \text{ mm}/(\text{mK})$

**Example:** A 12 metre-long TECEflex gas line made of composite pipe is installed at 5 °C in winter. Operating conditions can lead to a temperature of 35 °C.

$$l = 12 \text{ m}$$

$$\Delta t = 35 \text{ K} - 5 \text{ K} = 30 \text{ K}$$

$$\alpha = 0.026 \text{ mm}/(\text{mK})$$

$$\Delta l = 0.026 \text{ mm}/(\text{mK}) \cdot 12 \text{ m} \cdot 30 \text{ K} = 9.36 \text{ mm}$$

Result: The pipe will expand by approx. 10 mm. The expansion must be compensated for via structural conditions. Alternatively, the thermal length extension can be found in the following diagrams.

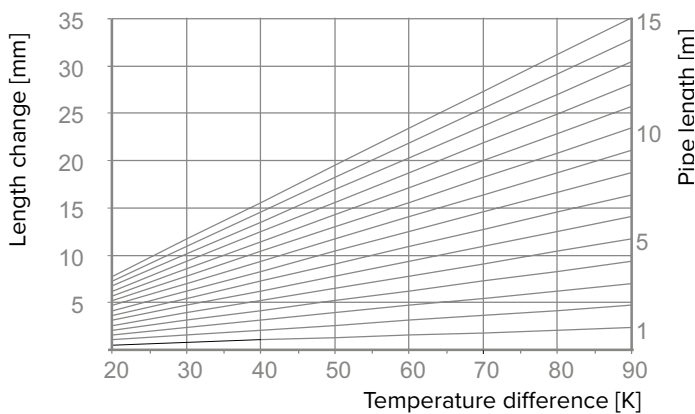

Thermal length extension TECEflex composite pipes

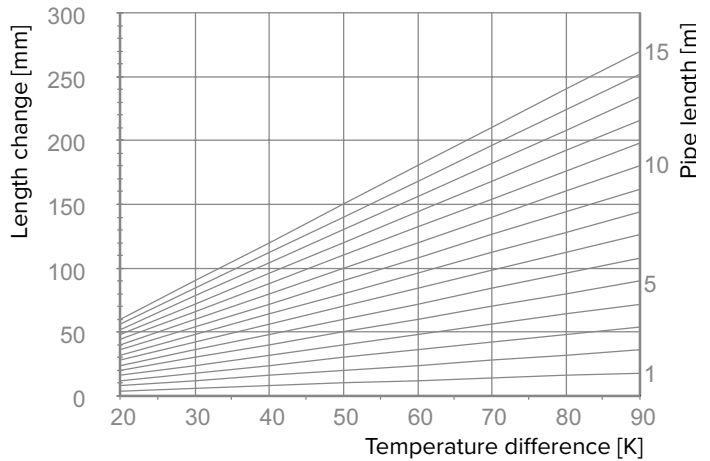

Thermal length extension TECEflex PE-Xc or PE-MD-Xc pipes

### Determining the length of the bending leg

The bending leg length (b) can be found in the following diagram:

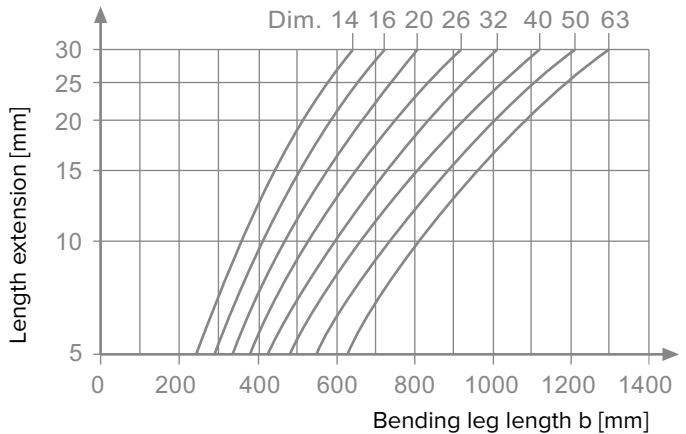

Bending leg length for TECEflex pipes

The pipe lengths to be observed can be isolated using fixed and sliding clamps. The length extension in compressed air and gas installations can normally be compensated by pipe design with direction changes.

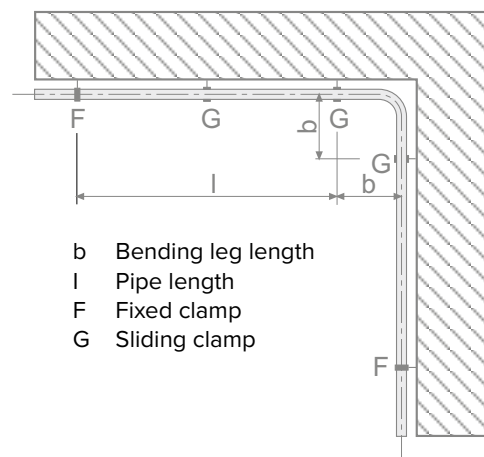

Compensation of thermal linear extension in a direction change

It can happen that the planned pipe design does not offer sufficient room for movement for the inclusion of thermal linear extension. In this case, compensating bends should be included in the plan that take into account the bending leg lengths.

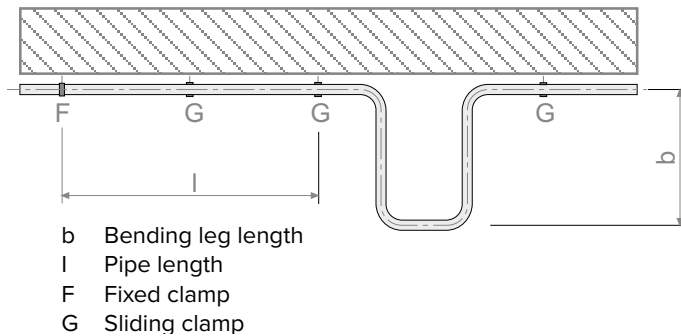

Compensation of thermal linear extension in an extension loop

Example:

The pipe length extension in the aforementioned example is approx. 10 mm. The bending leg length  $b$  can be found in the aforementioned diagram. For a TECEflex pipe with a dimension of 20 mm this results in a value of 470 mm. If a sliding clamp of at least 470 mm is fitted to the elbow then no additional compensating elbow is required.

### Special installation notes for linear extension

- Only TECEflex composite piping is approved for skirting board systems.
- Take care to ensure sufficient “room to manoeuvre” when connection radiators from the floor or wall in order to include linear extension.
- The connection should always be guided to the radiators in an elbow design.
- PPSU fittings should be installed tension-free. If necessary, suitable attachments should be arranged to decouple the PPSU fittings from the influence of the length extension.

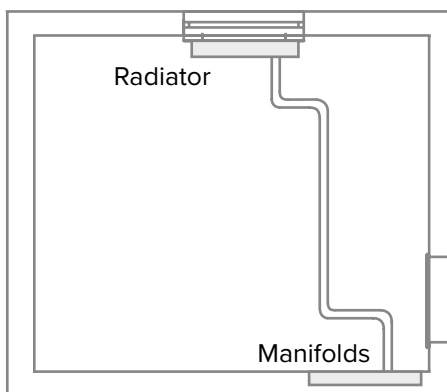

Example installation taking into account linear extension

### Attaching conduit

TECEflex pipelines are only to be attached using the approved pipe clips for the relevant purpose. Commercially available wall plugs can be used to attach clamps as long as they are used on components with sufficient mechanical stability. The TECEflex pipelines may not be attached to other lines.

### Attaching gas lines

Pipe holders made of combustible materials are approved for use with TECEflex gas lines. Commercially available wall plugs can be used to attach clamps as long as they are used on components with sufficient mechanical stability. The TECEflex gas lines may not be attached to other lines. Other lines may also not be attached to gas lines.

### Routing of water-bearing TECEflex lines

The routing of TECEflex installation lines must comply with the recognised rules of engineering. The quality of the drinking water must not be negatively affected by the conduit. To prevent the multiplication of microorganisms, the routing and insulation should be selected so that the drinking water is not heated. The cold drinking water pipes - in shafts and pre-walls in particular - should be checked to see if they require additional insulation for hygiene reasons. The drinking water may not be heated above 25 °C.

### TECEflex lines on plaster

The type and spacing of the attachment depend on the construction conditions on site. The fixing of the pipelines should be carried out using static perspectives taking into consideration the filled and insulated pipes according to the recognised rules of the technology.

| TECEflex pipe dimension | Attachment spacing in m |
|-------------------------|-------------------------|
| 14                      | 1                       |
| 16                      | 1                       |
| 20                      | 1.15                    |
| 25                      | 1.3                     |
| 32                      | 1.5                     |
| 40                      | 1.8                     |
| 50                      | 2                       |
| 63                      | 2                       |

Attachment distances for TECEflex lines installed on plaster.

# TECEflex - Installation Guidelines

| TECEflex dimension | Pipe weight filled in kg/m |
|--------------------|----------------------------|
| 14                 | 0.19                       |
| 16                 | 0.24                       |
| 20                 | 0.37                       |
| 25                 | 0.55                       |
| 32                 | 0.85                       |
| 40                 | 1.33                       |
| 50                 | 2.12                       |
| 63                 | 3.33                       |

TECEflex pipe masses

The pipes should be laid so that they cannot be affected by moisture from other fittings such as drips or condensation.

## Concealed TECEflex lines

Depending on the wall composition or quality of the masonry, the thermal length extension of a concealed TECEflex composite pipe can cause damage to the wall. TECE therefore recommends that all concealed TECEflex composite pipes be fitted with pipe insulation. The pre-insulated TECEflex pipes fulfil this requirement.

Alternatively, if no thermal insulation is required, the composite pipes can be laid in corrugated pipe sheathing. These pipes are also part of the TECEflex range. TECEflex fittings must be fundamentally protected from contact with the wall structure, plasterboard, cement, screed, rapid binders or similar using suitable coverings. Direct contact with the structural shell must be avoided at all costs owing to the sound insulation requirements in accordance with DIN 4109 and VDI 4100.

## TECEflex lines in concrete or screed

The pipes are solidly enclosed by concrete or screed so that the linear extension of the pipe material occurs on the inside. Special measures to include thermal linear extension are unnecessary in this instance. If the pipes are laid in the insulation layer between concrete and screed, however, they should be arranged so that the expected linear extension is compensated by the insulation or a pipe guide laid inside the elbow.

Heat insulation and impact sound requirements must be met. The corresponding standards and guidelines must be adhered to. It is therefore advisable to install the TECEflex pipes in a suitable levelling course. The additional installation height must be considered during planning. The fittings must be protected against corrosion.

TECEflex pipes installed on bare floor surfaces or in concrete ceilings should be attached at a maximum distance

of one metre. It should be ensured that the TECEflex pipes installed on bare floor surfaces are not damaged by ladders, equipment, wheelbarrows, constant impacts or similar. The pipelines must be inspected immediately before the screed is laid.

## TECEflex lines guided through movement joints

If pipelines are guided through building expansion joints, these must be laid in corrugated pipe sheathing. The corrugated pipe sheathing must sit at least 25 cm above the movement joint on all sides. Thermal insulation with a wall thickness of at least 6 mm may be used as an alternative to corrugated sheath piping.

## Piperun in floor structures

For planning and laying of pipes in floor structures, the screed trade has described in the guideline titled "Pipes, cable and cable channels on unfinished floors" how piperuns have to be carried out: "Pipelines in the floor assembly must be installed free of junctions, in straight lines as well as axially parallel and parallel to the wall. Even as early as the planning stage heating and drinking water lines should already take priority over electrical lines and conduits should be removed."

- The pipelines in a pipe route must be grouped together as tightly as possible.
- **Caution:**The installation should be performed so that cold water lines are not heated over 25 °C if warm pipes are laid directly beside cold drinking water lines.
- The pipe route containing lines laid in parallel inclusive of pipe insulation may be a maximum of 30 cm wide.
- The space between the individual lines should adhere to a minimum distance of 20 cm. The minimum distance of a line to a wall is 20 cm.
- The dimensions given above should be adhered to as closely as possible next to manifold housings.
- Around the door the distance from the door jamb should be a minimum of 10 cm.

Pipes of different thicknesses or other fittings within the line must be balanced to create an even surface for the impact sound insulation.



## Sound insulation

The noise behaviour of a drinking water heating installation in relation to the building structure should be taken into consideration during the planning and implementation.

The requirements for sound insulation are governed by local legislation, standards and guidelines.

### Sound-insulated installation of the TECEflex system

For water-bearing pipelines, special attention should be paid to structure-borne noise. The installation therefore has to be mounted so as to be decoupled from the building structure:

- Use of pipe attachments that insulate against structure-borne noise.
- Pipes passed through screed or in walls must be equipped with at least 9 mm of insulation. The TECEflex range offers appropriately pre-insulated pipes. Corrugated sheath pipes as coverings do not offer sufficient sound insulation.
- Dry-wall pre-wall installations such as TECEprofil, for example, offer better sound insulation for sanitary items mounted directed on the wall because they are decoupled from the building structure.
- Drinking water and heating installations must only be installed on correspondingly solid walls with a weight of at least 220 kg/m<sup>2</sup>.
- The resting pressure should not exceed 5 bar.
- The permitted through-flow values of fittings should be adhered to.
- Water-bearing pipes should not - if possible - be installed on walls connected to rooms requiring protection.

## Fire protection

The corresponding local laws, standards and guidelines on fire protection as well as the generally recognised state of the art should be observed and adhered to during the installation.

## TECElogo - Planning and design

### Dimensioning of drinking water systems

The planning and installation of drinking water systems are governed by local legislation, standards and guidelines.

#### Hygiene requirements

A drinking water installation must ensure that the water at the tapping point meets the requirements of the Drinking Water Ordinance. All metal fittings intended for use with drinking water are only composed of materials that comply with the UBA's metal evaluation principles (as at 17/03/2017) or the 4MS materials list (as at 05/01/2017). The biological and chemical suitability of the TECEflex system is confirmed by the DVGW certification and additional European approvals. The technical measures to be taken to reduce the growth of Legionella as well as the planning, operation and restoration of drinking water systems are described in the DVGW worksheet W 551. Among others, the following points should be considered during the planning:

#### Hydraulic design

Dimensioning and planning of drinking water lines with TECEflex is based on local legislation, standards and guidelines. The necessary product-specific information can be found in the following figures and tables.

# TECEflex - Planning and application

## Loss coefficient of TECEflex fittings

| Fitting              | Version        | Zeta value | Equivalent pipe length (m) |
|----------------------|----------------|------------|----------------------------|
| Transition connector | 14 mm x 1/2"   | 0.8        | 0.2                        |
| Coupling             | 14 mm          | 1          | 0.3                        |
| Angle                | 14 mm          | 4          | 1.1                        |
| Tee TT               | 14 mm          | 0.8        | 0.2                        |
| Tee OT               | 14 mm          | 4          | 1.1                        |
| Transition connector | 16 mm x 1/2"   | 1          | 0.3                        |
| Coupling             | 16 mm          | 0.5        | 0.2                        |
| Angle                | 16 mm          | 3.2        | 1.3                        |
| Elbow                | 16 mm          | 1.1        | 1.3                        |
| Tee TT               | 16 mm          | 0.8        | 0.3                        |
| Tee OT               | 16 mm          | 3.6        | 1.5                        |
| Transition connector | 20 mm x 3/4"   | 1.7        | 0.6                        |
| Coupling             | 20 mm          | 0.9        | 0.5                        |
| Angle                | 20 mm          | 4.3        | 2.4                        |
| Elbow                | 20 mm          | 1.9        | 2.4                        |
| Tee TT               | 20 mm          | 1.1        | 0.6                        |
| Tee OT               | 20 mm          | 4.7        | 2.6                        |
| Transition connector | 25 mm x 3/4"   | 0.8        | 0.4                        |
| Coupling             | 25 mm          | 0.3        | 0.2                        |
| Angle                | 25 mm          | 2.3        | 1.7                        |
| Elbow                | 25 mm          | 1.1        | 1.7                        |
| Tee TT               | 25 mm          | 0.6        | 0.4                        |
| Tee OT               | 25 mm          | 2.6        | 1.9                        |
| Transition connector | 32 mm x 1"     | 0.5        | 0.3                        |
| Coupling             | 32 mm          | 0.2        | 0.2                        |
| Angle                | 32 mm          | 2.4        | 2.5                        |
| Elbow                | 32 mm          | 0.6        | 2.5                        |
| Tee TT               | 32 mm          | 0.3        | 0.3                        |
| Tee OT               | 32 mm          | 2.5        | 2.6                        |
| Transition connector | 40 mm x 1 1/4" | 0.4        | 0.4                        |
| Coupling             | 40 mm          | 0.2        | 0.2                        |
| Angle                | 40 mm          | 2.1        | 2                          |
| Elbow                | 40 mm          | 0.6        | 2                          |
| Tee TT               | 40 mm          | 0.3        | 0.3                        |
| Tee OT               | 40 mm          | 2.2        | 2.2                        |
| Transition connector | 50 mm x 1 1/2" | 0.4        | 0.5                        |
| Coupling             | 50 mm          | 0.1        | 0.2                        |
| Angle                | 50 mm          | 1.8        | 2.3                        |
| Elbow                | 50 mm          | 0.5        | 2.3                        |
| Tee TT               | 50 mm          | 0.2        | 2.3                        |
| Tee OT               | 50 mm          | 1.9        | 2.5                        |
| Transition connector | 63 mm x 2"     | 0.3        | 0.6                        |
| Coupling             | 63 mm          | 0.1        | 0.2                        |
| Angle                | 63 mm          | 2.2        | 3.7                        |
| Elbow                | 63 mm          | 0.6        | 3.7                        |
| Tee TT               | 63 mm          | 0.5        | 0.8                        |
| Tee OT               | 63 mm          | 2.2        | 3.7                        |

## Pressure loss tables in the drinking water installation – Dimensions 14/16/20/25 mm

| TECEflex composite pipes – Pressure losses due to pipe friction for drinking water lines |         |        |        |         |        |        |         |        |        |         |        |        |
|--|---------|--------|--------|---------|--------|--------|---------|--------|--------|---------|--------|--------|
| Water<br>speed   | Dim. 14 |        |        | Dim. 16 |        |        | Dim. 20 |        |        | Dim. 25 |        |        |
|  | V       | m      | R      | V       | m      | R      | V       | m      | R      | V       | m      | R      |
|  | l/s     | kg/h   | mbar/m | l/s     | kg/h   | mbar/m | l/s     | kg/h   | mbar/m | l/s     | kg/h   | mbar/m |
| 0.1  | 0.008   | 28.3   | 0.4    | 0.011   | 38.0   | 0.3    | 0.016   | 58.6   | 0.2    | 0.025   | 91.6   | 0.1    |
| 0.2  | 0.012   | 42.4   | 0.6    | 0.016   | 57.1   | 0.5    | 0.024   | 87.9   | 0.3    | 0.038   | 137.4  | 0.2    |
| 0.2  | 0.016   | 56.5   | 0.8    | 0.021   | 76.1   | 0.6    | 0.033   | 117.3  | 0.4    | 0.051   | 183.2  | 0.5    |
| 0.3  | 0.020   | 70.7   | 1.0    | 0.026   | 95.1   | 0.8    | 0.041   | 146.6  | 1.0    | 0.064   | 229.0  | 0.7    |
| 0.3  | 0.024   | 84.8   | 1.3    | 0.032   | 114.1  | 1.8    | 0.049   | 175.9  | 1.3    | 0.076   | 274.8  | 1.0    |
| 0.4  | 0.027   | 99.0   | 2.8    | 0.037   | 133.2  | 2.3    | 0.057   | 205.2  | 1.7    | 0.089   | 320.6  | 1.3    |
| 0.4  | 0.031   | 113.1  | 3.5    | 0.042   | 152.2  | 2.9    | 0.065   | 234.5  | 2.2    | 0.102   | 366.4  | 1.6    |
| 0.5  | 0.035   | 127.2  | 4.3    | 0.048   | 171.2  | 3.5    | 0.073   | 263.8  | 2.7    | 0.115   | 412.2  | 2.0    |
| 0.5  | 0.039   | 141.4  | 5.1    | 0.053   | 190.2  | 4.2    | 0.081   | 293.1  | 3.2    | 0.127   | 458.0  | 2.4    |
| 0.6  | 0.043   | 155.5  | 6.1    | 0.058   | 209.3  | 5.0    | 0.090   | 322.5  | 3.8    | 0.140   | 503.8  | 2.8    |
| 0.6  | 0.047   | 169.6  | 7.0    | 0.063   | 228.3  | 5.8    | 0.098   | 351.8  | 4.4    | 0.153   | 549.7  | 3.3    |
| 0.7  | 0.051   | 183.8  | 8.1    | 0.069   | 247.3  | 6.7    | 0.106   | 381.1  | 5.1    | 0.165   | 595.5  | 3.8    |
| 0.7  | 0.055   | 197.9  | 9.2    | 0.074   | 266.3  | 7.6    | 0.114   | 410.4  | 5.7    | 0.178   | 641.3  | 4.3    |
| 0.8  | 0.059   | 212.1  | 10.3   | 0.079   | 285.3  | 8.5    | 0.122   | 439.7  | 6.5    | 0.191   | 687.1  | 4.9    |
| 0.8  | 0.063   | 226.2  | 11.6   | 0.085   | 304.4  | 9.6    | 0.130   | 469.0  | 7.3    | 0.204   | 732.9  | 5.5    |
| 0.9  | 0.067   | 240.3  | 12.9   | 0.090   | 323.4  | 10.6   | 0.138   | 498.4  | 8.1    | 0.216   | 778.7  | 6.1    |
| 0.9  | 0.071   | 254.5  | 14.2   | 0.095   | 342.4  | 11.7   | 0.147   | 527.7  | 8.9    | 0.229   | 824.5  | 6.7    |
| 1.0  | 0.075   | 268.6  | 15.6   | 0.100   | 361.4  | 12.9   | 0.155   | 557.0  | 9.8    | 0.242   | 870.3  | 7.4    |
| 1.0  | 0.079   | 282.7  | 17.1   | 0.106   | 380.5  | 14.1   | 0.163   | 586.3  | 10.7   | 0.254   | 916.1  | 8.1    |
| 1.1  | 0.082   | 296.9  | 18.6   | 0.111   | 399.5  | 15.4   | 0.171   | 615.6  | 11.7   | 0.267   | 961.9  | 8.8    |
| 1.2  | 0.094   | 339.3  | 23.5   | 0.127   | 456.6  | 19.4   | 0.195   | 703.6  | 14.8   | 0.305   | 1099.3 | 11.2   |
| 1.3  | 0.102   | 367.6  | 27.0   | 0.137   | 494.6  | 22.4   | 0.212   | 762.2  | 17.0   | 0.331   | 1190.9 | 12.9   |
| 1.4  | 0.113   | 405.3  | 32.1   | 0.151   | 545.3  | 26.6   | 0.233   | 840.4  | 20.2   | 0.365   | 1313.1 | 15.3   |
| 1.5  | 0.118   | 424.1  | 34.8   | 0.159   | 570.7  | 28.8   | 0.244   | 879.4  | 21.9   | 0.382   | 1374.1 | 16.6   |
| 1.6  | 0.126   | 452.4  | 39.0   | 0.169   | 608.7  | 32.3   | 0.261   | 938.1  | 24.6   | 0.407   | 1465.7 | 18.6   |
| 1.7  | 0.134   | 480.7  | 43.4   | 0.180   | 646.8  | 36.0   | 0.277   | 996.7  | 27.4   | 0.433   | 1557.4 | 20.7   |
| 1.8  | 0.141   | 508.9  | 48.0   | 0.190   | 684.8  | 39.8   | 0.293   | 1055.3 | 30.3   | 0.458   | 1649.0 | 23.0   |
| 1.9  | 0.149   | 537.2  | 52.9   | 0.201   | 722.9  | 43.8   | 0.309   | 1114.0 | 33.4   | 0.483   | 1740.6 | 25.3   |
| 2.0  | 0.157   | 565.5  | 57.9   | 0.211   | 760.9  | 48.0   | 0.326   | 1172.6 | 36.6   | 0.509   | 1832.2 | 27.7   |
| 2.1  | 0.165   | 593.8  | 63.2   | 0.222   | 799.0  | 52.4   | 0.342   | 1231.2 | 40.0   | 0.534   | 1923.8 | 30.3   |
| 2.2  | 0.173   | 622.0  | 68.6   | 0.233   | 837.0  | 56.9   | 0.358   | 1289.9 | 43.4   | 0.560   | 2015.4 | 32.9   |
| 2.3  | 0.181   | 650.3  | 74.3   | 0.243   | 875.1  | 61.7   | 0.375   | 1348.5 | 47.0   | 0.585   | 2107.0 | 35.6   |
| 2.4  | 0.188   | 678.6  | 80.2   | 0.254   | 913.1  | 66.5   | 0.391   | 1407.1 | 50.8   | 0.611   | 2198.6 | 38.5   |
| 2.5  | 0.196   | 706.9  | 86.3   | 0.264   | 951.1  | 71.6   | 0.407   | 1465.7 | 54.6   | 0.636   | 2290.2 | 41.4   |
| 2.6  | 0.204   | 735.1  |        | 0.275   | 989.2  |        | 0.423   | 1524.4 |        | 0.662   | 2381.8 | 44.4   |
| 2.7  | 0.212   | 763.4  |        | 0.285   | 1027.2 |        | 0.440   | 1583.0 |        | 0.687   | 2473.4 | 47.5   |
| 2.8  | 0.220   | 791.7  |        | 0.296   | 1065.3 |        | 0.456   | 1641.6 |        | 0.713   | 2565.0 | 50.8   |
| 2.9  | 0.228   | 820.0  |        | 0.306   | 1103.3 |        | 0.472   | 1700.3 |        | 0.738   | 2656.7 | 54.1   |
| 3.0  | 0.236   | 848.2  |        | 0.317   | 1141.4 |        | 0.489   | 1758.9 |        | 0.763   | 2748.3 | 57.5   |
| 3.6  | 0.283   | 1017.9 |        | 0.380   | 1369.7 |        | 0.586   | 2110.7 |        | 0.916   | 3297.9 | 80.1   |
| 4.0  | 0.314   | 1131.0 |        | 0.423   | 1521.8 |        | 0.651   | 2345.2 |        | 1.018   | 3664.4 | 97.1   |
| 4.6  | 0.361   | 1300.6 |        | 0.486   | 1750.1 |        | 0.749   | 2697.0 |        | 1.171   | 4214.0 | 125.3  |
| 5.0  | 0.393   | 1413.7 |        | 0.528   | 1902.3 |        | 0.814   | 2931.5 |        | 1.272   | 4580.4 | 146.0  |

# TECEflex - Planning and application

## Pressure loss tables in the drinking water installation – Dimensions 32/40/50/63 mm

| TECEflex composite pipes – Pressure losses due to pipe friction for drinking water lines |         |        |       |         |         |      |         |         |      |         |         |       |     |      |
|--|---------|--------|-------|---------|---------|------|---------|---------|------|---------|---------|-------|-----|------|
| Water speed  | Dim. 32 |        |       | Dim. 40 |         |      | Dim. 50 |         |      | Dim. 63 |         |       |     |      |
|  | V       | m      | R     | V       | m       | R    | V       | m       | R    | V       | m       | R     |     |      |
|  | m/s     | l/s    | kg/h  | hPa/m   | l/s     | kg/h | mbar/m  | hPa/m   | l/s  | kg/h    | mbar/m  | hPa/m | l/s | kg/h |
| 0.1  | 0.045   | 162.9  | 0.1   | 0.080   | 289.5   | 0.1  | 0.132   | 475.3   | 0.1  | 0.204   | 735.4   | 0.0   |     |      |
| 0.2  | 0.068   | 244.3  | 0.2   | 0.121   | 434.3   | 0.1  | 0.198   | 712.9   | 0.1  | 0.306   | 1103.1  | 0.1   |     |      |
| 0.2  | 0.090   | 325.7  | 0.3   | 0.161   | 579.1   | 0.2  | 0.264   | 950.6   | 0.2  | 0.409   | 1470.8  | 0.1   |     |      |
| 0.3  | 0.113   | 407.2  | 0.5   | 0.201   | 723.8   | 0.3  | 0.330   | 1188.2  | 0.3  | 0.511   | 1838.5  | 0.2   |     |      |
| 0.3  | 0.136   | 488.6  | 0.7   | 0.241   | 868.6   | 0.5  | 0.396   | 1425.9  | 0.3  | 0.613   | 2206.2  | 0.3   |     |      |
| 0.4  | 0.158   | 570.0  | 0.9   | 0.281   | 1013.4  | 0.6  | 0.462   | 1663.5  | 0.5  | 0.715   | 2574.0  | 0.3   |     |      |
| 0.4  | 0.181   | 651.4  | 1.1   | 0.322   | 1158.1  | 0.8  | 0.528   | 1901.2  | 0.6  | 0.817   | 2941.7  | 0.4   |     |      |
| 0.5  | 0.204   | 732.9  | 1.4   | 0.362   | 1302.9  | 1.0  | 0.594   | 2138.8  | 0.7  | 0.919   | 3309.4  | 0.5   |     |      |
| 0.5  | 0.226   | 814.3  | 1.7   | 0.402   | 1447.6  | 1.2  | 0.660   | 2376.5  | 0.8  | 1.021   | 3677.1  | 0.6   |     |      |
| 0.6  | 0.249   | 895.7  | 2.0   | 0.442   | 1592.4  | 1.4  | 0.726   | 2614.1  | 1.0  | 1.124   | 4044.8  | 0.8   |     |      |
| 0.6  | 0.271   | 977.2  | 2.3   | 0.483   | 1737.2  | 1.6  | 0.792   | 2851.7  | 1.2  | 1.226   | 4412.5  | 0.9   |     |      |
| 0.7  | 0.294   | 1058.6 | 2.6   | 0.523   | 1881.9  | 1.8  | 0.858   | 3089.4  | 1.3  | 1.328   | 4780.2  | 1.0   |     |      |
| 0.7  | 0.317   | 1140.0 | 3.0   | 0.563   | 2026.7  | 2.1  | 0.924   | 3327.0  | 1.5  | 1.430   | 5147.9  | 1.2   |     |      |
| 0.8  | 0.339   | 1221.5 | 3.4   | 0.603   | 2171.5  | 2.4  | 0.990   | 3564.7  | 1.7  | 1.532   | 5515.6  | 1.3   |     |      |
| 0.8  | 0.362   | 1302.9 | 3.8   | 0.643   | 2316.2  | 2.6  | 1.056   | 3802.3  | 1.9  | 1.634   | 5883.3  | 1.5   |     |      |
| 0.9  | 0.385   | 1384.3 | 4.2   | 0.684   | 2461.0  | 2.9  | 1.122   | 4040.0  | 2.2  | 1.736   | 6251.0  | 1.7   |     |      |
| 0.9  | 0.407   | 1465.7 | 4.7   | 0.724   | 2605.8  | 3.3  | 1.188   | 4277.6  | 2.4  | 1.839   | 6618.7  | 1.8   |     |      |
| 1.0  | 0.430   | 1547.2 | 5.1   | 0.764   | 2750.5  | 3.6  | 1.254   | 4515.3  | 2.6  | 1.941   | 6986.4  | 2.0   |     |      |
| 1.0  | 0.452   | 1628.6 | 5.6   | 0.804   | 2895.3  | 3.9  | 1.320   | 4752.9  | 2.9  | 2.043   | 7354.2  | 2.2   |     |      |
| 1.1  | 0.475   | 1710.0 | 6.1   | 0.844   | 3040.1  | 4.3  | 1.386   | 4990.6  | 3.2  | 2.145   | 7721.9  | 2.4   |     |      |
| 1.2  | 0.543   | 1954.3 | 7.8   | 0.965   | 3474.4  | 5.4  | 1.584   | 5703.5  | 4.0  | 2.451   | 8825.0  | 3.1   |     |      |
| 1.3  | 0.588   | 2117.2 | 9.0   | 1.046   | 3763.9  | 6.3  | 1.716   | 6178.8  | 4.6  | 2.656   | 9560.4  | 3.5   |     |      |
| 1.4  | 0.648   | 2334.3 | 10.7  | 1.153   | 4149.9  | 7.5  | 1.892   | 6812.5  | 5.5  | 2.928   | 10541.0 | 4.2   |     |      |
| 1.5  | 0.679   | 2442.9 | 11.6  | 1.206   | 4342.9  | 8.1  | 1.980   | 7129.4  | 6.0  | 3.064   | 11031.2 | 4.6   |     |      |
| 1.6  | 0.724   | 2605.8 | 13.0  | 1.287   | 4632.5  | 9.1  | 2.112   | 7604.7  | 6.7  | 3.269   | 11766.6 | 5.1   |     |      |
| 1.7  | 0.769   | 2768.6 | 14.5  | 1.367   | 4922.0  | 10.1 | 2.244   | 8080.0  | 7.5  | 3.473   | 12502.1 | 5.7   |     |      |
| 1.8  | 0.814   | 2931.5 | 16.0  | 1.448   | 5211.5  | 11.2 | 2.376   | 8555.2  | 8.3  | 3.677   | 13237.5 | 6.3   |     |      |
| 1.9  | 0.860   | 3094.3 | 17.7  | 1.528   | 5501.1  | 12.4 | 2.508   | 9030.5  | 9.1  | 3.881   | 13972.9 | 7.0   |     |      |
| 2.0  | 0.905   | 3257.2 | 19.4  | 1.608   | 5790.6  | 13.6 | 2.641   | 9505.8  | 10.0 | 4.086   | 14708.3 | 7.7   |     |      |
| 2.1  | 0.950   | 3420.1 | 21.2  | 1.689   | 6080.1  | 14.8 | 2.773   | 9981.1  | 11.0 | 4.290   | 15443.7 | 8.4   |     |      |
| 2.2  | 0.995   | 3582.9 | 23.0  | 1.769   | 6369.6  | 16.1 | 2.905   | 10456.4 | 11.9 | 4.494   | 16179.1 | 9.1   |     |      |
| 2.3  | 1.040   | 3745.8 | 24.9  | 1.850   | 6659.2  | 17.5 | 3.037   | 10931.7 | 12.9 | 4.698   | 16914.6 | 9.9   |     |      |
| 2.4  | 1.086   | 3908.6 | 26.9  | 1.930   | 6948.7  | 18.9 | 3.169   | 11407.0 | 13.9 | 4.903   | 17650.0 | 10.7  |     |      |
| 2.5  | 1.131   | 4071.5 | 29.0  | 2.011   | 7238.2  | 20.3 | 3.301   | 11882.3 | 15.0 | 5.107   | 18385.4 | 11.5  |     |      |
| 2.6  | 1.176   | 4234.4 | 31.1  | 2.091   | 7527.8  | 21.8 | 3.433   | 12357.6 | 16.1 | 5.311   | 19120.8 | 12.4  |     |      |
| 2.7  | 1.221   | 4397.2 | 33.3  | 2.171   | 7817.3  | 23.4 | 3.565   | 12832.9 | 17.3 | 5.516   | 19856.2 | 13.2  |     |      |
| 2.8  | 1.267   | 4560.1 | 35.6  | 2.252   | 8106.8  | 25.0 | 3.697   | 13308.2 | 18.5 | 5.720   | 20591.6 | 14.2  |     |      |
| 2.9  | 1.312   | 4722.9 | 37.9  | 2.332   | 8396.3  | 26.6 | 3.829   | 13783.5 | 19.7 | 5.924   | 21327.0 | 15.1  |     |      |
| 3.0  | 1.357   | 4885.8 | 40.3  | 2.413   | 8685.9  | 28.3 | 3.961   | 14258.7 | 20.9 | 6.128   | 22062.5 | 16.0  |     |      |
| 3.6  | 1.629   | 5863.0 | 56.2  | 2.895   | 10423.1 | 39.5 | 4.753   | 17110.5 | 29.2 | 7.354   | 26475.0 | 22.4  |     |      |
| 4.0  | 1.810   | 6514.4 | 68.1  | 3.217   | 11581.2 | 47.9 | 5.281   | 19011.7 | 35.4 | 8.171   | 29416.6 | 27.2  |     |      |
| 4.6  | 2.081   | 7491.6 | 88.0  | 3.700   | 13318.3 | 61.9 | 6.073   | 21863.4 | 45.8 | 9.397   | 33829.1 | 35.2  |     |      |
| 5.0  | 2.262   | 8143.0 | 102.6 | 4.021   | 14476.5 | 72.2 | 6.601   | 23764.6 | 53.4 | 10.214  | 36770.8 | 41.0  |     |      |

## Pressure loss tables for the heating installation – Dimensions 14/16/20/25 mm

| Pressure loss due to pipe friction in the heating installation |       |       |      |           |         |        |         |        |         |        |         |        |  |
|--|-------|-------|------|-----------|---------|--------|---------|--------|---------|--------|---------|--------|--|
| Connection capacity (W)  |       |       |      | Mass flux | Dim. 14 |        | Dim. 16 |        | Dim. 20 |        | Dim. 25 |        |  |
|  |       |       |      |           | v       | R      | v       | R      | v       | R      | v       | R      |  |
| Spread (K)   |       |       |      | kg/h      | hPa/m   |        | hPa/m   |        | hPa/m   |        | hPa/m   |        |  |
| 20 K   | 15 K  | 10 K  | 5 K  |           | m/s     | mbar/m | m/s     | mbar/m | m/s     | mbar/m | m/s     | mbar/m |  |
| 200  | 150   | 100   | 50   | 8.60      | 0.03    | 0.13   | 0.02    | 0.07   |         |        |         |        |  |
| 300  | 225   | 150   | 75   | 12.90     | 0.05    | 0.19   | 0.03    | 0.11   |         |        |         |        |  |
| 400  | 300   | 200   | 100  | 17.20     | 0.06    | 0.25   | 0.05    | 0.14   |         |        |         |        |  |
| 600  | 450   | 300   | 150  | 25.80     | 0.09    | 0.38   | 0.07    | 0.21   |         |        |         |        |  |
| 800  | 600   | 400   | 200  | 34.39     | 0.12    | 0.51   | 0.09    | 0.28   |         |        |         |        |  |
| 1000   | 750   | 500   | 250  | 42.99     | 0.15    | 0.64   | 0.11    | 0.35   |         |        |         |        |  |
| 1200   | 900   | 600   | 300  | 51.59     | 0.18    | 0.76   | 0.14    | 0.42   |         |        |         |        |  |
| 1400   | 1050  | 700   | 350  | 60.19     | 0.21    | 0.89   | 0.16    | 0.49   |         |        |         |        |  |
| 1600   | 1200  | 800   | 400  | 68.79     | 0.24    | 1.02   | 0.18    | 0.56   |         |        |         |        |  |
| 1800   | 1350  | 900   | 450  | 77.39     | 0.27    | 1.15   | 0.20    | 0.63   |         |        |         |        |  |
| 2000   | 1500  | 1000  | 500  | 85.98     | 0.30    | 2.21   | 0.23    | 0.70   | 0.15    | 0.30   |         |        |  |
| 2300   | 1725  | 1150  | 575  | 98.88     | 0.35    | 2.80   | 0.26    | 0.81   | 0.17    | 0.34   |         |        |  |
| 2800   | 2100  | 1400  | 700  | 120.38    | 0.43    | 3.91   | 0.32    | 1.94   | 0.21    | 0.42   |         |        |  |
| 3000   | 2250  | 1500  | 750  | 128.98    | 0.46    | 4.40   | 0.34    | 2.18   | 0.22    | 0.79   |         |        |  |
| 3500   | 2625  | 1750  | 875  | 150.47    | 0.53    | 5.73   | 0.40    | 2.84   | 0.26    | 1.02   |         |        |  |
| 4000   | 3000  | 2000  | 1000 | 171.97    | 0.61    | 7.21   | 0.45    | 3.57   | 0.29    | 1.29   | 0.19    | 0.45   |  |
| 4500   | 3375  | 2250  | 1125 | 193.47    | 0.68    | 8.83   | 0.51    | 4.37   | 0.33    | 1.57   | 0.21    | 0.55   |  |
| 5000   | 3750  | 2500  | 1250 | 214.96    | 0.76    | 10.60  | 0.57    | 5.24   | 0.37    | 1.88   | 0.23    | 0.66   |  |
| 5500   | 4125  | 2750  | 1375 | 236.46    | 0.84    | 12.50  | 0.62    | 6.17   | 0.40    | 2.22   | 0.26    | 0.77   |  |
| 6000   | 4500  | 3000  | 1500 | 257.95    | 0.91    | 14.55  | 0.68    | 7.18   | 0.44    | 2.57   | 0.28    | 0.90   |  |
| 6500   | 4875  | 3250  | 1625 | 279.45    | 0.99    | 16.73  | 0.73    | 8.25   | 0.48    | 2.95   | 0.31    | 1.03   |  |
| 7000   | 5250  | 3500  | 1750 | 300.95    | 1.06    | 19.04  | 0.79    | 9.38   | 0.51    | 3.36   | 0.33    | 1.17   |  |
| 7500   | 5625  | 3750  | 1875 | 322.44    |         |        | 0.85    | 10.58  | 0.55    | 3.78   | 0.35    | 1.31   |  |
| 8000   | 6000  | 4000  | 2000 | 343.94    |         |        | 0.90    | 11.84  | 0.59    | 4.23   | 0.38    | 1.47   |  |
| 8500   | 6375  | 4250  | 2125 | 365.43    |         |        | 0.96    | 13.16  | 0.62    | 4.70   | 0.40    | 1.63   |  |
| 9000   | 6750  | 4500  | 2250 | 386.93    |         |        | 1.02    | 14.55  | 0.66    | 5.19   | 0.42    | 1.80   |  |
| 9500   | 7125  | 4750  | 2375 | 408.43    |         |        | 1.07    | 16.00  | 0.70    | 5.70   | 0.45    | 1.98   |  |
| 10000  | 7500  | 5000  | 2500 | 429.92    |         |        |         |        | 0.73    | 6.23   | 0.47    | 2.16   |  |
| 10500  | 7875  | 5250  | 2625 | 451.42    |         |        |         |        | 0.77    | 6.79   | 0.49    | 2.35   |  |
| 11000  | 8250  | 5500  | 2750 | 472.91    |         |        |         |        | 0.81    | 7.36   | 0.52    | 2.55   |  |
| 11500  | 8625  | 5750  | 2875 | 494.41    |         |        |         |        | 0.84    | 7.96   | 0.54    | 2.75   |  |
| 12500  | 9375  | 6250  | 3125 | 537.40    |         |        |         |        | 0.92    | 9.21   | 0.59    | 3.18   |  |
| 13000  | 9750  | 6500  | 3250 | 558.90    |         |        |         |        | 0.95    | 9.86   | 0.61    | 3.40   |  |
| 14000  | 10500 | 7000  | 3500 | 601.89    |         |        |         |        | 1.03    | 11.23  | 0.66    | 3.87   |  |
| 15000  | 11250 | 7500  | 3750 | 644.88    |         |        |         |        |         |        | 0.70    | 4.37   |  |
| 16000  | 12000 | 8000  | 4000 | 687.88    |         |        |         |        |         |        | 0.75    | 4.89   |  |
| 17000  | 12750 | 8500  | 4250 | 730.87    |         |        |         |        |         |        | 0.80    | 5.44   |  |
| 18000  | 13500 | 9000  | 4500 | 773.86    |         |        |         |        |         |        | 0.85    | 6.01   |  |
| 19000  | 14250 | 9500  | 4750 | 816.85    |         |        |         |        |         |        | 0.89    | 6.61   |  |
| 20000  | 15000 | 10000 | 5000 | 859.85    |         |        |         |        |         |        | 0.94    | 7.24   |  |
| 22000  | 16500 | 11000 | 5500 | 945.83    |         |        |         |        |         |        | 1.03    | 8.56   |  |

# TECEflex - Planning and application

## Pressure loss tables for the heating installation – Dimensions 32/40/50/63 mm (part 1)

| Pressure loss due to pipe friction in the heating installation |       |       |       |           |         |        |         |        |         |        |         |        |  |
|--|-------|-------|-------|-----------|---------|--------|---------|--------|---------|--------|---------|--------|--|
| Connection capacity (W)  |       |       |       | Mass flux | Dim. 32 |        | Dim. 40 |        | Dim. 50 |        | Dim. 63 |        |  |
|  |       |       |       |           | v       | R      | v       | R      | v       | R      | v       | R      |  |
| Spread (K)   |       |       |       | kg/h      | hPa/m   |        | hPa/m   |        | hPa/m   |        | hPa/m   |        |  |
| 20 K   | 15 K  | 10 K  | 5 K   |           | m/s     | mbar/m | m/s     | mbar/m | m/s     | mbar/m | m/s     | mbar/m |  |
| 7000   | 5250  | 3500  | 1750  | 300.95    | 0.18    | 0.30   |         |        |         |        |         |        |  |
| 7500   | 5625  | 3750  | 1875  | 322.44    | 0.20    | 0.34   |         |        |         |        |         |        |  |
| 8000   | 6000  | 4000  | 2000  | 343.94    | 0.21    | 0.38   |         |        |         |        |         |        |  |
| 8500   | 6375  | 4250  | 2125  | 365.43    | 0.22    | 0.42   |         |        |         |        |         |        |  |
| 9000   | 6750  | 4500  | 2250  | 386.93    | 0.24    | 0.46   |         |        |         |        |         |        |  |
| 9500   | 7125  | 4750  | 2375  | 408.43    | 0.25    | 0.51   |         |        |         |        |         |        |  |
| 10000  | 7500  | 5000  | 2500  | 429.92    | 0.26    | 0.55   |         |        |         |        |         |        |  |
| 10500  | 7875  | 5250  | 2625  | 451.42    | 0.28    | 0.60   |         |        |         |        |         |        |  |
| 11000  | 8250  | 5500  | 2750  | 472.91    | 0.29    | 0.65   | 0.16    | 0.17   |         |        |         |        |  |
| 11500  | 8625  | 5750  | 2875  | 494.41    | 0.30    | 0.70   | 0.17    | 0.18   |         |        |         |        |  |
| 12500  | 9375  | 6250  | 3125  | 537.40    | 0.33    | 0.81   | 0.19    | 0.21   |         |        |         |        |  |
| 13000  | 9750  | 6500  | 3250  | 558.90    | 0.34    | 0.87   | 0.19    | 0.22   |         |        |         |        |  |
| 14000  | 10500 | 7000  | 3500  | 601.89    | 0.37    | 0.99   | 0.21    | 0.25   |         |        |         |        |  |
| 15000  | 11250 | 7500  | 3750  | 644.88    | 0.40    | 1.11   | 0.22    | 0.28   |         |        |         |        |  |
| 16000  | 12000 | 8000  | 4000  | 687.88    | 0.42    | 1.24   | 0.24    | 0.32   |         |        |         |        |  |
| 17000  | 12750 | 8500  | 4250  | 730.87    | 0.45    | 1.38   | 0.25    | 0.35   |         |        |         |        |  |
| 18000  | 13500 | 9000  | 4500  | 773.86    | 0.48    | 1.53   | 0.27    | 0.39   |         |        |         |        |  |
| 19000  | 14250 | 9500  | 4750  | 816.85    | 0.50    | 1.68   | 0.28    | 0.43   |         |        |         |        |  |
| 20000  | 15000 | 10000 | 5000  | 859.85    | 0.53    | 1.84   | 0.30    | 0.47   |         |        |         |        |  |
| 22000  | 16500 | 11000 | 5500  | 945.83    | 0.58    | 2.17   | 0.33    | 0.55   |         |        |         |        |  |
| 24000  | 18000 | 12000 | 6000  | 1031.81   | 0.63    | 2.52   | 0.36    | 0.64   |         |        |         |        |  |
| 26000  | 19500 | 13000 | 6500  | 1117.80   | 0.69    | 2.90   | 0.39    | 0.74   |         |        |         |        |  |
| 28000  | 21000 | 14000 | 7000  | 1203.78   | 0.74    | 3.31   | 0.42    | 0.84   |         |        |         |        |  |
| 30000  | 22500 | 15000 | 7500  | 1289.77   | 0.79    | 3.73   | 0.45    | 0.95   | 0.27    | 0.29   |         |        |  |
| 32000  | 24000 | 16000 | 8000  | 1375.75   | 0.85    | 4.19   | 0.48    | 1.06   | 0.29    | 0.33   |         |        |  |
| 34000  | 25500 | 17000 | 8500  | 1461.74   | 0.90    | 4.66   | 0.51    | 1.18   | 0.31    | 0.36   |         |        |  |
| 36000  | 27000 | 18000 | 9000  | 1547.72   | 0.95    | 5.15   | 0.53    | 1.30   | 0.33    | 0.40   |         |        |  |
| 38000  | 28500 | 19000 | 9500  | 1633.71   | 1.00    | 5.67   | 0.56    | 1.43   | 0.34    | 0.44   |         |        |  |
| 40000  | 30000 | 20000 | 10000 | 1719.69   |         |        | 0.59    | 1.57   | 0.36    | 0.48   |         |        |  |
| 42000  | 31500 | 21000 | 10500 | 1805.67   |         |        | 0.62    | 1.71   | 0.38    | 0.52   |         |        |  |
| 44000  | 33000 | 22000 | 11000 | 1891.66   |         |        | 0.65    | 1.85   | 0.40    | 0.57   |         |        |  |
| 46000  | 34500 | 23000 | 11500 | 1977.64   |         |        | 0.68    | 2.01   | 0.42    | 0.62   |         |        |  |
| 48000  | 36000 | 24000 | 12000 | 2063.63   |         |        | 0.71    | 2.16   | 0.43    | 0.66   | 0.28    | 0.23   |  |
| 50000  | 37500 | 25000 | 12500 | 2149.61   |         |        | 0.74    | 2.32   | 0.45    | 0.71   | 0.29    | 0.25   |  |
| 52000  | 39000 | 26000 | 13000 | 2235.60   |         |        | 0.77    | 2.49   | 0.47    | 0.76   | 0.30    | 0.27   |  |
| 54000  | 40500 | 27000 | 13500 | 2321.58   |         |        | 0.80    | 2.66   | 0.49    | 0.81   | 0.32    | 0.29   |  |
| 56000  | 42000 | 28000 | 14000 | 2407.57   |         |        | 0.83    | 2.84   | 0.51    | 0.87   | 0.33    | 0.31   |  |
| 58000  | 43500 | 29000 | 14500 | 2493.55   |         |        | 0.86    | 3.02   | 0.52    | 0.92   | 0.34    | 0.33   |  |
| 60000  | 45000 | 30000 | 15000 | 2579.54   |         |        | 0.89    | 3.21   | 0.54    | 0.98   | 0.35    | 0.35   |  |
| 62000  | 46500 | 31000 | 15500 | 2665.52   |         |        | 0.92    | 3.40   | 0.56    | 1.04   | 0.36    | 0.37   |  |
| 64000  | 48000 | 32000 | 16000 | 2751.50   |         |        | 0.95    | 3.60   | 0.58    | 1.10   | 0.37    | 0.39   |  |
| 66000  | 49500 | 33000 | 16500 | 2837.49   |         |        | 0.98    | 3.80   | 0.60    | 1.16   | 0.39    | 0.41   |  |
| 68000  | 51000 | 34000 | 17000 | 2923.47   |         |        | 1.01    | 4.00   | 0.62    | 1.22   | 0.40    | 0.43   |  |
| 70000  | 52500 | 35000 | 17500 | 3009.46   |         |        | 1.04    | 4.22   | 0.63    | 1.29   | 0.41    | 0.45   |  |
| 72000  | 54000 | 36000 | 18000 | 3095.44   |         |        | 1.07    | 4.43   | 0.65    | 1.35   | 0.42    | 0.48   |  |

## Pressure loss tables for the heating installation – Dimensions 32/40/50/63 mm (part 2)

| Pressure loss due to pipe friction in the heating installation |        |        |       |           |         |        |         |        |         |        |         |        |  |
|--|--------|--------|-------|-----------|---------|--------|---------|--------|---------|--------|---------|--------|--|
| Connection capacity (W)  |        |        |       | Mass flux | Dim. 32 |        | Dim. 40 |        | Dim. 50 |        | Dim. 63 |        |  |
|  |        |        |       |           | v       | R      | v       | R      | v       | R      | v       | R      |  |
| Spread (K)   |        |        |       | kg/h      | hPa/m   |        | hPa/m   |        | hPa/m   |        | hPa/m   |        |  |
| 20 K   | 15 K   | 10 K   | 5 K   |           | m/s     | mbar/m | m/s     | mbar/m | m/s     | mbar/m | m/s     | mbar/m |  |
| 76000  | 57000  | 38000  | 19000 | 3267.41   |         |        |         |        | 0.69    | 1.49   | 0.44    | 0.52   |  |
| 80000  | 60000  | 40000  | 20000 | 3439.38   |         |        |         |        | 0.72    | 1.63   | 0.47    | 0.57   |  |
| 84000  | 63000  | 42000  | 21000 | 3611.35   |         |        |         |        | 0.76    | 1.78   | 0.49    | 0.63   |  |
| 88000  | 66000  | 44000  | 22000 | 3783.32   |         |        |         |        | 0.80    | 1.93   | 0.51    | 0.68   |  |
| 92000  | 69000  | 46000  | 23000 | 3955.29   |         |        |         |        | 0.83    | 2.09   | 0.54    | 0.73   |  |
| 96000  | 72000  | 48000  | 24000 | 4127.26   |         |        |         |        | 0.87    | 2.25   | 0.56    | 0.79   |  |
| 100000   | 75000  | 50000  | 25000 | 4299.23   |         |        |         |        | 0.90    | 2.42   | 0.58    | 0.85   |  |
| 104000   | 78000  | 52000  | 26000 | 4471.20   |         |        |         |        | 0.94    | 2.59   | 0.61    | 0.91   |  |
| 108000   | 81000  | 54000  | 27000 | 4643.16   |         |        |         |        | 0.98    | 2.77   | 0.63    | 0.98   |  |
| 112000   | 84000  | 56000  | 28000 | 4815.13   |         |        |         |        | 1.01    | 2.96   | 0.65    | 1.04   |  |
| 116000   | 87000  | 58000  | 29000 | 4987.10   |         |        |         |        | 1.05    | 3.15   | 0.68    | 1.11   |  |
| 120000   | 90000  | 60000  | 30000 | 5159.07   |         |        |         |        | 1.09    | 3.35   | 0.70    | 1.18   |  |
| 124000   | 93000  | 62000  | 31000 | 5331.04   |         |        |         |        |         |        | 0.73    | 1.25   |  |
| 128000   | 96000  | 64000  | 32000 | 5503.01   |         |        |         |        |         |        | 0.75    | 1.32   |  |
| 132000   | 99000  | 66000  | 33000 | 5674.98   |         |        |         |        |         |        | 0.77    | 1.39   |  |
| 136000   | 102000 | 68000  | 34000 | 5846.95   |         |        |         |        |         |        | 0.80    | 1.47   |  |
| 140000   | 105000 | 70000  | 35000 | 6018.92   |         |        |         |        |         |        | 0.82    | 1.55   |  |
| 144000   | 108000 | 72000  | 36000 | 6190.89   |         |        |         |        |         |        | 0.84    | 1.63   |  |
| 148000   | 111000 | 74000  | 37000 | 6362.85   |         |        |         |        |         |        | 0.87    | 1.71   |  |
| 152000   | 114000 | 76000  | 38000 | 6534.82   |         |        |         |        |         |        | 0.89    | 1.79   |  |
| 156000   | 117000 | 78000  | 39000 | 6706.79   |         |        |         |        |         |        | 0.91    | 1.87   |  |
| 160000   | 120000 | 80000  | 40000 | 6878.76   |         |        |         |        |         |        | 0.94    | 1.96   |  |
| 164000   | 123000 | 82000  | 41000 | 7050.73   |         |        |         |        |         |        | 0.96    | 2.05   |  |
| 168000   | 126000 | 84000  | 42000 | 7222.70   |         |        |         |        |         |        | 0.98    | 2.14   |  |
| 172000   | 129000 | 86000  | 43000 | 7394.67   |         |        |         |        |         |        | 1.01    | 2.23   |  |
| 176000   | 132000 | 88000  | 44000 | 7566.64   |         |        |         |        |         |        | 1.03    | 2.33   |  |
| 180000   | 135000 | 90000  | 45000 | 7738.61   |         |        |         |        |         |        | 1.05    | 2.42   |  |
| 184000   | 138000 | 92000  | 46000 | 7910.58   |         |        |         |        |         |        | 1.08    | 2.52   |  |
| 188000   | 141000 | 94000  | 47000 | 8082.55   |         |        |         |        |         |        | 1.10    | 2.62   |  |
| 192000   | 144000 | 96000  | 48000 | 8254.51   |         |        |         |        |         |        | 1.12    | 2.72   |  |
| 196000   | 147000 | 98000  | 49000 | 8426.48   |         |        |         |        |         |        | 1.15    | 2.82   |  |
| 200000   | 150000 | 100000 | 50000 | 8598.45   |         |        |         |        |         |        | 1.17    | 2.92   |  |

# TECEflex - Planning and application

## Guide values and installation times

The following table contains the guide values for the assembly of pipes and pressure sleeve connectors in running metres, ready laid, including attachment for chase and pre-wall installation in single and multiple-family homes, shown in group minutes.

| TECEflex<br>Ø in mm | Installation time for run. m. ready laid,<br>incl. attachment in group minutes |
|---------------------|--|
| 14                  | 5–9  |
| 16                  | 5–9  |
| 20                  | 6–10   |
| 25                  | 7–11   |
| 32                  | 8–12   |
| 40                  | 14–16  |
| 50                  | 16–18  |
| 63                  | 18–20  |

**Note:** The group minutes stated relate to fitters with system experience.

## Rinsing drinking water systems

The pipes must be rinsed thoroughly before the drinking water installation is commissioned. Local legislation, standards and guidelines should be considered here.

## Pressure test of drinking water systems

A test pressure should be carried out for drinking water installations in accordance with DIN EN 806-4. The requirements of the pressure test in DIN EN 806-4 are supplemented by VDI/DVGW 6023 and the ZVSHK data sheet "Leak tests of drinking water installation with pressure tests using compressed air, inert gas or water". Before the pressure test is performed it should be ensured that all components in the installation are freely accessible and visible in order to be able to localise incorrectly installed fittings. If the piping system remains unfilled following a pressure test (e.g. because a regular water replacement cannot be guaranteed at the latest after 72 hours), it is recommended that a pressure test be performed using compressed air or inert gases.

### Leak test with oil-free compressed air or inert gas

The pipe connections should be visually inspected before the leak test is performed. Components in the piping system must be suitable for the test pressures or enlarged prior to the line test, replaced by a suitable piece of piping or tested separately at the ends of the pipe in line sections.

After applying the test pressure of 150 mbar (150 hPa), the testing period up to 100 litre line volume must be at least

120 minutes. The testing period must be extended by 20 minutes for every additional 100 litres of line volume.

The testing begins once the test pressure is reached, taking into account a corresponding waiting time for the stabilisation of media and ambient temperature. The seal tightness is determined by the agreement of the start and end test pressures, up to the normal fluctuations caused by the temperature of the medium and the pressure at the pressure gauge.

The pressure gauge used must show a corresponding accuracy of 1 mbar (1 hPa) in the display area for the pressures to be measured. The U-pipe pressure gauge known from the TRGI test or the standpipes can be used here.

### Load test

The purpose of this test is to identify faults that could lead to the rupture or dislocation of a connection in the specified piping system under normal operating conditions.

The strength test is combined with a visual inspection of all pipe connections. The test consists of filling the piping system to be tested with a medium under pressure (maximum 3 bar).

The load test with increased pressure should be carried out

- at maximum 3 bar for nominal values up to DN 50, and
- Nominal values above DN 50 (up to DN 100) maximum 1 bar

The testing period following the application of the test pressure is 10 minutes.

The state of the pressure gauge must remain constant during the testing period. For TECElogo installations, a steady state should be achieved first before the testing period begins. For other materials, the temperature constant required in the piping system must be reached before the test begins. The pressure gauge used must show an accuracy of 100 mbar (100 hPa) in the display area.

### Use of leak detectors

Only use leak detectors (e.g. foam building agents) with a current DVGW certification that are also approved by their respective manufacturers for use with the material PPSU.

### Preparation for leak test with water

All pipe connections should be visually inspected before the leak test with water. The testing device should be connected to the deepest point of the installation to be tested.



Only testing devices that can guarantee a maximum measurement accuracy of 0.1 bar (100 hPa) should be used.

The installation should be filled with filtered drinking water (particle size  $\leq 150 \mu\text{m}$ ), ventilated and protected against freezing. Shut-off device in front of and behind heat generators and boilers must be closed so the test pressure can be held back from the rest of the system.

If significant disparities arise between the ambient temperature and water temperature ( $>10 \text{ K}$ ), a 30 minute waiting period should be implemented following the application of the system test pressure to allow the temperature to equalise. The pressure must be maintained for at least 10 minutes. There must be no pressure drop or visible sign of a loose seal.

### Performing the leak test

The pipeline system is first loaded with a test pressure that must be  $1.1 \times$  the operating pressure (in relation to the deepest point in the system). The operating pressure is 10 bar (1 MPa) in accordance with DIN EN 806-2. This means a test pressure of 11 bar (1.1 MPa) is required. A subsequent inspection should be performed on the pipe section tested to be able to determine any possible leakage.

After a testing period of 30 minutes, water should be drained to reduce the pressure to 5.5 bar (0.55 MPa), corresponding to  $0.5 \times$  the starting test pressure. The testing period at this pressure is 120 minutes. There must be no leak in evidence during this testing period. The test pressure at the pressure gauge must remain constant ( $\Delta p = 0$ ). A pressure drop during the testing period indicates there is a leak in the system. The pressure must be maintained and the leaky sites determined. The defect must be rectified and the leak test then repeated.

### Please remember:

For hygiene reasons, TECE recommends carrying out a leak test with oil-free compressed air or inert gas in a leak test with drinking water.

### Heating systems

A heating system must be rinsed thoroughly prior to commissioning to remove metallic residues or liquids. The TECElogo system is immune to these contaminants but metallic components of the heating system - such as radiators or heat generators - can sustain damage from galvanic corrosion processes.

The leak test is carried out the same way as the leak test for drinking water installations. Here the test pressure must be  $1.3 \times$  the operating pressure, however.

# TECEflex - Planning and application

Pressure test log for drinking water installations – in accordance with DIN EN 806-4, supplemented by VDI/DVGW 6023 and ZVSHK data sheet (Leak tests of drinking water installation with pressure tests using compressed air, inert gas or water) – with the test medium oil-free compressed air or inert gas

Construction: \_\_\_\_\_

Customer: \_\_\_\_\_

Constructor/Fitter: \_\_\_\_\_

Pipeline system material: \_\_\_\_\_

Connection type: \_\_\_\_\_

Installation pressure: \_\_\_\_\_ bar

Ambient temperature \_\_\_\_\_ °C      Temperature of test medium \_\_\_\_\_ °C

Testing medium:  oil-free compressed air     hydrogen     carbon dioxide     \_\_\_\_\_

The drinking water system has been tested as:       Total system     in \_\_\_\_\_ Sections

## Leak test

Test pressure:      150 mbar

Testing period up to 100 litres line volume:      min. 120 minutes  
(for every additional 100 litres the testing period should be increased by 20 minutes)

Pipe volumes:      \_\_\_\_\_ litres

Testing period:      \_\_\_\_\_ minutes

Wait for temperature adjustment and steady state, then begin the testing period.

No pressure drop was detected during the testing period.

## Strength test with increased pressure

Test pressure up to and including DN 50:      3 bar

Test pressure over DN 50 up to DN 100:      1 bar

Testing period up to 100 litres pipe volume:      min. 10 minutes

Testing period:      \_\_\_\_\_ minutes

Wait for temperature adjustment and steady state, then begin the testing period.

No pressure drop was detected during the testing period.

The piping system is sealed.

\_\_\_\_\_  
Location

\_\_\_\_\_  
Date

\_\_\_\_\_  
Customer  
(Signature)

\_\_\_\_\_  
Contractor/Fitter  
(Stamp/Signature)

Pressure test log for drinking water installations – in accordance with DIN EN 806-4, supplemented by VDI/DVGW 6023 and ZVSHK data sheet (Leak tests of drinking water installation with pressure tests using compressed air, inert gas or water) – with the test medium drinking water

Construction: \_\_\_\_\_

Customer: \_\_\_\_\_

Fitter: \_\_\_\_\_

Dimension range from \_\_\_\_\_ mm to \_\_\_\_\_ mm

Line lengths approx. \_\_\_\_\_ m

Water temperature: \_\_\_\_\_ °C

Ambient temperature: \_\_\_\_\_ °C

The difference between the water temperature and ambient temperature must not be greater than 10 K!

**Leak test, part 1**

Testing period: 30 minutes

Test pressure: 11 bar (1.1 x operating pressure)

Pressure after 30 minutes

\_\_\_\_\_ bar

Result

\_\_\_\_\_

**Leak test, part 2**

Testing period: 120 minutes

Test pressure: 5.5 bar (0.5 x test pressure, part 1)

Pressure after 120 minutes

\_\_\_\_\_ bar

Result:

\_\_\_\_\_

\_\_\_\_\_  
Start of test (date, time)

\_\_\_\_\_  
End of test (date, time)

The VDI/DVGW 6023 requires that the system must be put back into operation within the next 72 hours following the leak test with water.

\_\_\_\_\_  
Commissioning of system (date, time)

\_\_\_\_\_  
Location

\_\_\_\_\_  
Date

\_\_\_\_\_  
Customer  
(Signature)

\_\_\_\_\_  
Contractor/Fitter  
(Stamp/Signature)

# TECEflex - Planning and application

Pressure testlog for heating systems – in accordance with DIN 18380 (VOB)

Construction: \_\_\_\_\_

Customer: \_\_\_\_\_

Contractor/Fitter: \_\_\_\_\_

Dimension range from \_\_\_\_\_ mm to \_\_\_\_\_ mm

Line lengths approx. \_\_\_\_\_ m

Water temperature: \_\_\_\_\_ °C

Ambient temperature: \_\_\_\_\_ °C

## Preliminary test

Testing period: 60 minutes

Test pressure: 1.3 x operating pressure in bar

Pressure after 30 minutes

\_\_\_\_\_ bar

Pressure after 60 minutes

\_\_\_\_\_ bar

Pressure loss over the last 30 minutes

\_\_\_\_\_ bar (maximum 0.6 bar)

Result of preliminary test

\_\_\_\_\_

## Main test

Testing period: 120 minutes

## Use the test pressure from the preliminary test

max. permitted pressure drop: 0.2 bar

Pressure at test start

\_\_\_\_\_ bar

Pressure after 120 minutes

\_\_\_\_\_ bar

Pressure drop during testing period

\_\_\_\_\_ bar (maximum 0.2 mbar)

Result of the main test:

\_\_\_\_\_

\_\_\_\_\_

Start of test

\_\_\_\_\_

End of test

\_\_\_\_\_

Location

\_\_\_\_\_

Date

\_\_\_\_\_

Customer/Representative  
(Signature)

\_\_\_\_\_

Contractor/Fitter  
(Stamp/Signature)

## Commissioning and instruction log for the drinking water system (page 1 of 2)

Construction project: \_\_\_\_\_

Customer/Representative: \_\_\_\_\_

Contractor/Representative: \_\_\_\_\_

In the absence of the persons named above, the following persons were trained in the use of the following system components and the system was put into operation:

| No. | System component, device                  | Acceptance completed     | Comment | n. a.                    |
|-----|---|--------------------------|---------|--------------------------|
| 1   | Home connection                           | <input type="checkbox"/> |         | <input type="checkbox"/> |
| 2   | Main shut-off valve                       | <input type="checkbox"/> |         | <input type="checkbox"/> |
| 3   | Return flow inhibitor                     | <input type="checkbox"/> |         | <input type="checkbox"/> |
| 4   | Backflow inhibitor                        | <input type="checkbox"/> |         | <input type="checkbox"/> |
| 5   | Filter                                    | <input type="checkbox"/> |         | <input type="checkbox"/> |
| 6   | Pressure relief system                    | <input type="checkbox"/> |         | <input type="checkbox"/> |
| 7   | Distribution lines                        | <input type="checkbox"/> |         | <input type="checkbox"/> |
| 8   | Risers/Shut-off valves                    | <input type="checkbox"/> |         | <input type="checkbox"/> |
| 9   | Multi-storey pipes/Shut-off valves        | <input type="checkbox"/> |         | <input type="checkbox"/> |
| 10  | Riser pipe aerator/Drip-water pipe        | <input type="checkbox"/> |         | <input type="checkbox"/> |
| 11  | Collector units/Drip-water pipe           | <input type="checkbox"/> |         | <input type="checkbox"/> |
| 12  | Tapping points with single guard          | <input type="checkbox"/> |         | <input type="checkbox"/> |
| 13  | Water heating/Drinking water heater       | <input type="checkbox"/> |         | <input type="checkbox"/> |
| 14  | Safety valves/Pressure relief lines       | <input type="checkbox"/> |         | <input type="checkbox"/> |
| 15  | Circulation line/Circulation pump         | <input type="checkbox"/> |         | <input type="checkbox"/> |
| 16  | Dosing unit                               | <input type="checkbox"/> |         | <input type="checkbox"/> |
| 17  | Softening unit                            | <input type="checkbox"/> |         | <input type="checkbox"/> |
| 18  | Pressure booster                          | <input type="checkbox"/> |         | <input type="checkbox"/> |
| 19  | Fire-extinguishing and protection systems | <input type="checkbox"/> |         | <input type="checkbox"/> |
| 20  | Swimming pool inflow                      | <input type="checkbox"/> |         | <input type="checkbox"/> |
| 21  | Extraction fittings                       | <input type="checkbox"/> |         | <input type="checkbox"/> |
| 22  | Consumption devices                       | <input type="checkbox"/> |         | <input type="checkbox"/> |
| 23  | Drinking water containers                 | <input type="checkbox"/> |         | <input type="checkbox"/> |
| 24  |   | <input type="checkbox"/> |         | <input type="checkbox"/> |
| 25  |   | <input type="checkbox"/> |         | <input type="checkbox"/> |
| 26  |   | <input type="checkbox"/> |         | <input type="checkbox"/> |
| 27  |   | <input type="checkbox"/> |         | <input type="checkbox"/> |

# TECEflex - Planning and application

## Commissioning and instruction log for the drinking water system (page 2 of 2)

Customer's supplementary remarks:

Contractor's supplementary remarks:

The instructions regarding the operation of the system were given, the required operating documents and existing instruction operation and maintenance document according to the aforementioned list were handed over. It has been mentioned that despite careful planning and design of the installation, drinking water of faultless quality can only be achieved at all tapping points if it is ensured that the water is completely replaced in all areas of the installation at regular intervals.

### Operator responsibilities: Measures during prolonged absence

| Absence    | Measures prior to absence   | Measures on return  |
|------------|---|---|
| > 3 days   | Homes:<br>Closure of multi-storey shut-off valves<br><br>Single family homes:<br>Closure of the shut-off valve behind the water meter | Once the shut-off valve is open, allow standing water to flow from all tapping points for 5 min (completely open) |
| > 4 weeks  | Homes:<br>Closure of multi-storey shut-off valves<br><br>Single family homes:<br>Closure of the shut-off valve behind the water meter | It is recommended to arrange a rinse of the home installation   |
| > 6 months | Arrange for the main shut-off valve (home connection) to be closed. Empty lines completely  | Arrange a rinse of the home installation  |
| > 1 year   | Separation of the connection line from the supply line  | Reconnection by water supply company or specialist fitter   |

Location

Date

Customer/Representative  
(Signature)

Contractor/Fitter  
(Signature)

## Radiator connection

The TECEflex system offers a comprehensive range of fittings for rational connection of radiators for most construction situations.

### Cross-fitting

The cross-fitting allows the splitting of the flow and return lines from two main lines running parallel to one another. The installation height of the fittings with insulation box is just 35 mm.

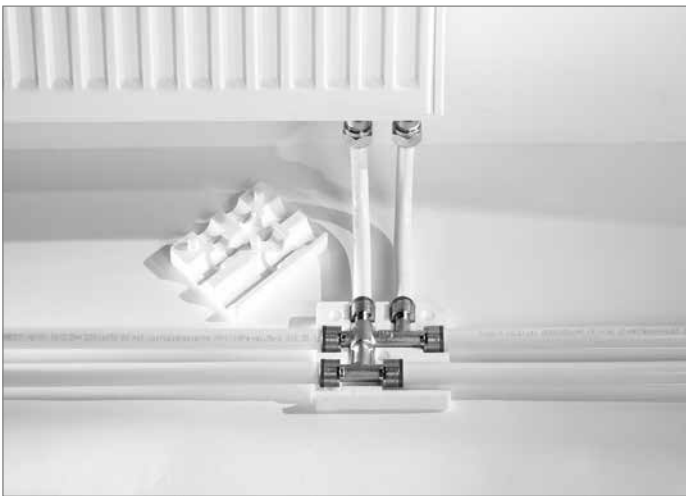

Radiator connection with cross-fitting

The use of cross-fittings not only saves assembly time but also negates the risk of damage to crossed pipes from wheelbarrows, crushing or similar.

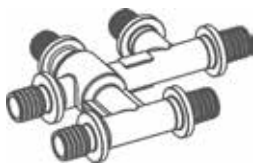

Cross-fitting  
(order no. 718501/ ...02/...03)

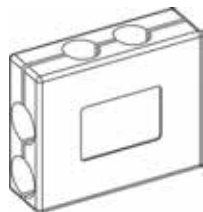

Protection box  
(order no. 718020)

### Connection from the floor

Radiators can be connected directly from the screed with the TECEflex composite pipe. The length extension of the pipe must be compensated to avoid “popping sounds”. The pipes should therefore be equipped with insulating tubing of at least 6 mm thick.

It is also recommended that a protective cuff be placed around the visible parts of the pipe. This thus avoids damage to the pipes via e.g. vacuuming.

### Radiator connection with mounting tees/elbows

The TECEflex range offers assembly tees made of nickel-plated copper for more demanding requirements. The elbow shape means a radiator can be connected using flow and return lines running parallel to one another.



Radiator connection with radiator mounting tee

The nickel-plated copper pipes are connected to the radiator valve block via a pinch screw connection.

Alternatively, if the flow and return lines do not run along the bottom of the radiator, the radiator mounting elbows made of nickel-plated copper can be used.



Radiator connection with radiator mounting elbow

## TECEflex - Radiator connection

### Connection from the wall

The special bending properties of the TECEflex composite pipe make it possible to connect the radiator directly from the wall. The chase in the wall must be able to accommodate the minimum bending radii of TECEflex pipes.

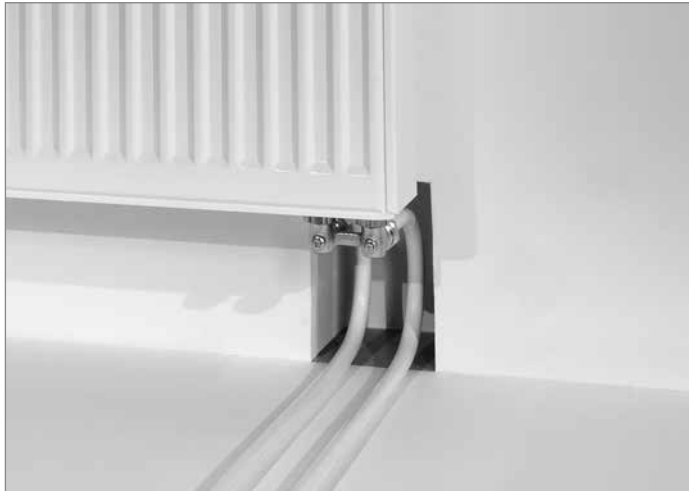

Radiator connection from the wall

### Radiator connection using the radiator mounting fitting for compact radiators from the wall

The radiator mounting fitting is equipped with sturdy fastening clips for secure fixing in the wall chase. TECEflex connection technology lets you connect pipes directly in the wall chase.



Radiator connection with radiator mounting unit - ready to push free



Radiator connection with radiator mounting fitting - connected to the valve block

The connection between the flow and return means the heating system can be pressed free without assembly plugs. To assemble the radiator, the U-pipe is suitably shortened and connected to the valve block via a pinch screw connection.

Alternatively, a radiator mounting fitting is available on the floor. It is also equipped with a U-pipe and allows you to push it free without assembly plugs.

TECEflex radiator mounting set dim. 16 x 15 mm Cu

### Connection from the wall with mounting unit

The radiator mounting unit can be equipped with pre-insulated pipes for optimum connection from the wall. A further feature is the especially tight radii of the TECEflex pipes.



Radiator connection with mounting unit - connected to the valve block



### Radiator connection from the skirting board

The TECEflex range offers a skirting board connection fitting with connection elbows or elbow shut-offs for connection from a skirting board. In the case of renovations, this allows radiators to be connected without any pressing work.

TECEflex composite pipes in skirting board systems may only be used together with brass fittings. TECE recommends using skirting boards from the company HZ.

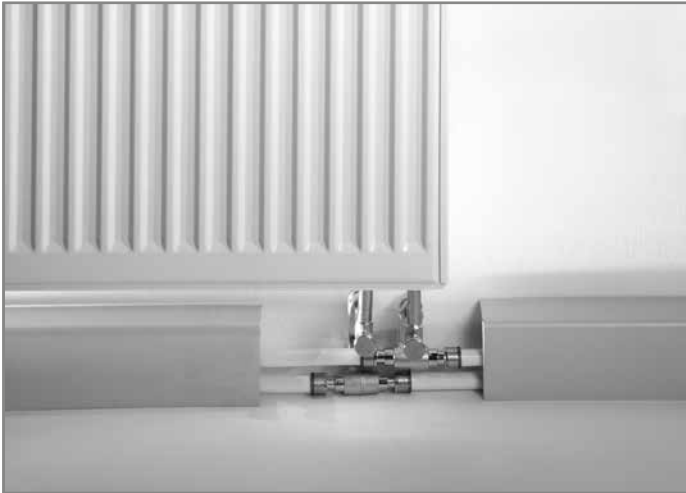

Radiator connection from the skirting board

# TECEflex - Compressed air installation

## Compressed air installation

### Design sizes for the pressure loss $\Delta p$

Compressed air installations with a maximum pressure  $p_{\max}$  of 8 bar or more should not exceed a total pressure loss through the pipe network to the consumer of  $\Delta P = 0.1$  bar. TECE recommends the following values for individual pipeline types:

- Main line  $\Delta p \leq 0.04$  bar
- Distribution line  $\Delta p \leq 0.04$  bar
- Connection lead  $\Delta p \leq 0.03$  bar

The following applies for pipeline networks with maximum pressures  $\leq 8$ :

Pipeline network pressure lost  $\Delta p \leq 1.5$  bar of  $p_{\max}$ .

### Oils

Oil may be present in the compressed air depending on the type of compressor. The compressed air is classified according to the maximum oil content permitted. The oil content can vary depending on class from 0.01 to 25 mg/m<sup>3</sup> compressed air. The TECEflex system is suitable for all qualities of compressor oil.

### Pressure test

TECE recommends performing a pressure test based on the technical rules for pressure tank classification (TRB 522) before commissioning a compressed air network. The test is split into two parts: leak test and strength test. Measures should be implemented to protect those involved in the work. During the test only those work personnel required for the test should be present on site.

### Leak test

It should be ensured that all open pipe outlets with stoppers, caps or similar are closed before the leak test is performed. The leak test should test the pipe network. Fittings, tools and pressure tanks should be removed from the network.

### Requirements:

- Test pressure 110 mbar
- Testing period up to 100 l pipe volume minimum 30 minutes
- The testing period must be extended by 10 minutes for every additional 100 litres of line volume. The testing period following the application of the test pressure is 15 minutes. The leak test is considered to be passed if the start and end pressure match once the testing period ends.

### Strength test

If the leak test was successful then the strength test can be performed directly afterwards. Here the test pressure is increased to 1.1 x the permitted system operating pressure.

The test pressure can be reapplied twice in the first 30 minutes after the test pressure is applied. It must then be maintained for 30 minutes. The pressure loss in this period must not exceed 0.1 mbar.

## Planning of a compressed air installation

Compressed air lines should always be installed in as straight a line as possible. The fewer fittings are used, the lower the pressure losses. This is why elbow couplings should be fitted with long hand-bent deflections when installing pipes.

Larger compressed air networks should be split into as many multiple sections as possible. The individual sections should each be fitted with a shut-off valve. This means there is always the option to take individual sections of the piping network out of operation in order to undertake repairs or expansion work.

Larger compressed air networks can make it thoroughly reasonable to integrate a second compressor station. This allows the pipe network to be supplied from a second point. This results in compressed air having shorter distances to travel and the pressure loss is reduced.

### Pipeline network without compressed air drying

If drying is not employed in compressed air systems, condensation forms as water droplets. In these instances, the following points should be considered to avoid damage to the compressed air consumers:

- Avoidance of cooldowns.  
The pipe guide should be selected so that the compressed air does not cool down on the way to the consumer. Ideally, the compressed air in the network should gradually warm up. This reduces the relative humidity of the air and avoids condensation forming.
- The compressed air lines must be laid at a gradient of approx. 1.5% to 2% in the direction of flow so the condensation can form at the deepest points in the pipe network.
- Main lines that run directly from the pressure tank should rise vertically. The resulting condensation then runs back into the pressure tank.
- Condensate drains must be installed at the deepest points in the pipe network.

- Connection leads must branch off upwards in the direction of flow.
- A maintenance unit with filter, water separator and pressure regulator should always be installed. Depending on the application, a second compressed air oiler may be necessary.

### Pipeline network with dry compressed air

If a compressed air dryer is installed in a compressed air network then the majority of measures concerning treatment of condensation can be ignored. Pipelines may also be laid without a gradient.

Condensate drains are only necessary on the filter in the compressed air tank and the compressed air dryer. Connection leads can be connected vertically downwards. Installation of a pipe network for dry compressed air is significantly cheaper. The purchase of a compressed air generally pays for itself even with smaller systems.

### Compressed air lines

A compressed air line is normally split into three line types:

- Main line
- Distribution line
- Connection lead

#### The main line

The main line connects the compressor with the distribution lines. Normally, the compressed air treatment and the compressed air tank are connected to the main line. These transport the total delivery volume of the compressor. The pressure loss in the main line should not exceed 0.04 mbar.

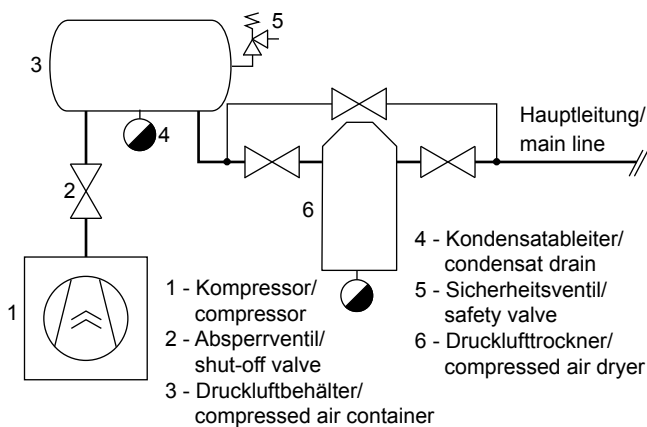

### Distribution line as a ring line

If possible, distribution lines should always be fitted as ring lines. This significantly increases the economic efficiency of the system. A ring line forms a closed distribution ring. This makes it possible to block off individual sections from the network without interrupting the supply of compressed air to the other sections. The compressed air has a shorter distance to travel here compared to stub distribution lines. This means you can calculate half the fluidic pipe length and half the volume flow when dimensioning the ring line.

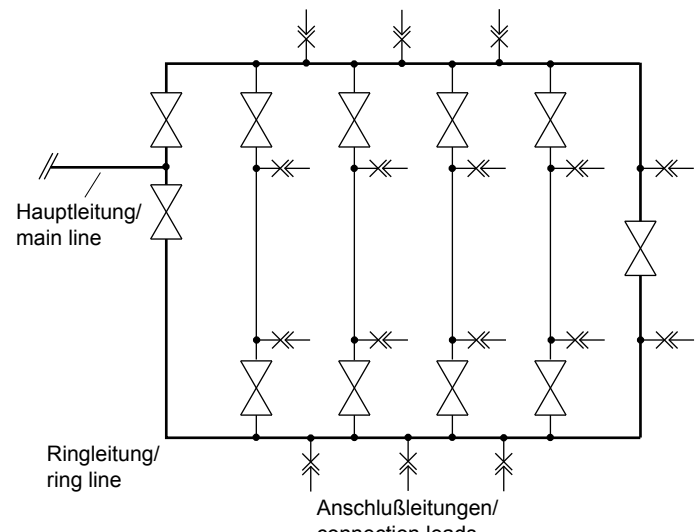

### The distribution line as a ring line

The stub lines connect the main line to the connection leads. Stub lines are often used to supply consumers located a little further away. Stub lines are often utilised in order to use fewer raw materials. This advantage is usually balanced out again, however, since they have to have larger dimensions than a ring line. The pressure loss in stub lines must not exceed 0.3 mbar.

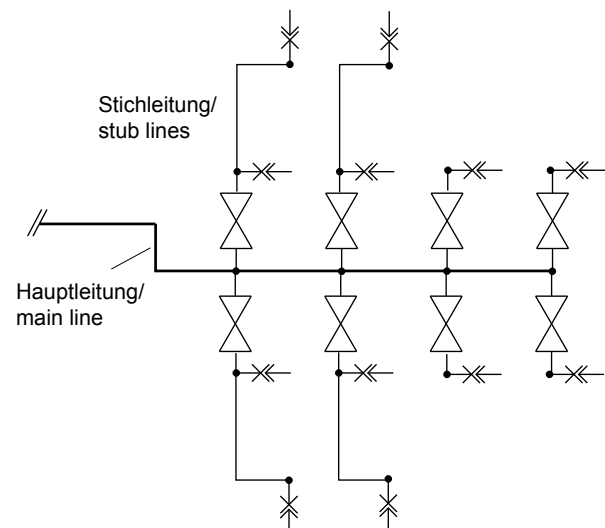

# TECEflex - Compressed air installation

## Connection leads

Connection leads connect the consumers with the supply line. As a rule, the compressed air consumers are operated using different pressures. This is why a pressure regulator is usually installed on the end of a connection lead. Connection leads are always connected to the distribution line from above and then guided downwards as otherwise a large amount of condensation or compressor oil collects in the connection lead. TECE recommends always installing connection leads in dimension 32 for the industrial sector. This dimension only entails low additional costs when compared to smaller measurements and generally always guarantees a secure supply of compressed air. With a connection length up to 10 metres, consumers with a compressed air requirement of up to 1800 litres per minute can be securely connected. The pressure loss in a connection lead should not exceed 0.3 mbar.

## Collection pipe

In multiple compressors are connected to a line, this is referred to as a collection pipe. The following points should be observed for these lines:

- Collection pipe with gradient:  
The collection pipe must be laid with a gradient in the direction of flow of approx. 1.5% to 2%. The connection lead must be connected to the collection line from above.
- With longer rising pipes, a water separator with automatic compressor drainage should be installed in order to compensate for the returning condensation.

## Calculation basis for compressed air installations

The correct dimensioning and design of a compressed air installation is in every operator's financial interest. Pipelines with dimensions that are too small cause high pressure losses in the pipe network. These must be balanced out again by higher air compression in order to be able to guarantee the necessary performance of the consumers. This would lead to excessively high costs for the system operator, however.

The following parameters influence the internal pipe diameter  $d_i$ :

## Nominal length (in m)

The pipe length must always be measured precisely. The equivalent pipe length should be used for fittings and moulded parts - the same equivalent pipe length can be used as in gas installation - and added to the pipe length measured.

As an estimate, the measured pipe length can also be multiplied by 1.6 (+60%). The result is the total pipe length needed to calculate the internal pipe diameter:

$$L_{\text{total}} = L_{\text{straight}} \cdot 1.6$$

This multiplier is the estimated share of individual resistances from pipe elbows, fittings and armatures.

## Volume flow ( $\dot{V}$ in l/s)

The greatest possible air through-flow should be assumed when establishing the internal pipe diameter  $d_i$  as an increased pressure drop has a particularly strong impact with maximum compressed air requirement.

## Operating pressure and overpressure (in bar)

For the calculation of the internal pipe diameter  $d_i$  the compressor shut-off pressure  $p_{\text{max}}$  should be assumed because with the highest pressure the pressure drop  $\Delta p$  is also highest.

## Dimensioning

There are various approaches for calculating the required internal pipe diameter. A relatively simple option is to calculate using the approximate formula.

$$d_i = \sqrt[5]{\frac{1,6 \cdot 10^3 \cdot \dot{V}^{1,85} \cdot L}{10^{10} \cdot \Delta p \cdot p_{\text{max}}}}$$

$d_i$  = internal diameter of pipeline [m]

$\dot{V}$  = total volume flow [m<sup>3</sup>/s]

$L$  = fluidic pipe length [m]

$\Delta p$  = intended pressure drop [bar]

$p_{\text{max}}$  = compressor shut-off pressure [barabs]

## Example 1

The internal pipe diameter  $d_i$  of a compressed air installation in a workshop should be calculated using the above approximate formula. The distribution line is built as a stub line. The intended total pressure loss is a  $\Delta p$  of 0.08 bar. The maximum operating pressure (compressor shut-off pressure) is 8 bar abs. The total pipe length is 75 metres, the number of fittings and moulded parts is unknown. A volume flow of 90 m<sup>3</sup>/h flows through this pipeline.

First, the fluidic total pipe length is now calculated as follows:

$$\begin{aligned} L_{\text{total}} &= 75 \text{ m} \cdot 1.6 \\ &= 120 \text{ m} \end{aligned}$$

$$\begin{aligned} \text{geg: } L &= 120 \text{ metres} \\ V &= 90 \text{ m}^3/\text{h} \Rightarrow 0.025 \text{ m}^3/\text{s} \\ \Delta p &= 0.08 \text{ bar} \\ p_{\text{max}} &= 8 \text{ bar} \end{aligned}$$

$$d_i = \sqrt[5]{\frac{1,6 \cdot 10^3 \cdot 0,025^{1,85} \cdot 120}{10^{10} \cdot 0,08 \cdot 8}}$$

$$\Rightarrow d_i = 0.032 \text{ m} \geq 32 \text{ mm}$$

Selected pipe dimension: TECEflex composite pipe dim.  
40 (40 x 4 mm)

### Example 2

For this example calculation we are using the same workshop as in the first example. The difference, however, is in the fact that the distribution line is installed as a ring line. Smaller pipe diameters are possible with a ring line, so the calculation can be made in this instance using the following adjusted approximate formula:

$$d_i = \sqrt[5]{\frac{1,6 \cdot 10^3 \cdot V^{1,85} \cdot L}{10^{10} \cdot \Delta p \cdot p_{\text{max}} \cdot 7,21}}$$

The constant 7.21 includes half the fluidic pipe length and half the volume flow.

This then leads to:

$$d_i = \sqrt[5]{\frac{1,6 \cdot 10^3 \cdot 0,025^{1,85} \cdot 120}{10^{10} \cdot 0,08 \cdot 8 \cdot 7,21}}$$

$$\Rightarrow d_i = 0.021 \text{ m} \geq 21 \text{ mm}$$

Selected pipe dimension: TECEflex composite pipe dim.  
32 (32 x 4 mm)

The calculation shows that the use of a ring line as a distribution line means in most instances the pipe dimension can be reduced by at least one dimension.

## TECEflex - Annex

## Resistance list PPSU

| Brand name                                | Date      | Concentration       | Manufacturer       | Use           |
|---|-----------|---------------------|--------------------|---------------|
| <b>Cooling lubricants</b>                 |           |                     |                    |               |
| Castrol nonol cooling lubricant           |           | 100%                | Castrol            | unpermitted   |
| Rocol RTD                                 |           | 100%                |                    | unpermitted   |
| Cooling lubricant M200 No. 1              | June 2009 | 100%                |                    | unpermitted   |
| <b>Disinfection agents</b>                |           |                     |                    |               |
| FINKTEC FT-99 CIP                         |           | 6%                  | Finktec GmbH       | unpermitted   |
| Mikro Quat                                |           | 100%                | Ecolab             | unpermitted   |
| Mikrobac forte                            |           | 1%, 23 °C           | Bode Chemie        | permitted     |
| Hydrogen peroxide                         |           | 35%, 23 °C          |                    | permitted     |
| Potassium permanganate KMnO <sub>4</sub>  |           | 15 mg/l, 23 °C      |                    | permitted     |
| Sodium hypochlorite NaOCl                 |           | > 6%, 23 °C         |                    | permitted     |
| Calcium hypochlorite Ca(ClO) <sub>2</sub> |           | 50 mg/l, 23 °C      |                    | permitted     |
| Chlorine dioxide ClO <sub>2</sub>         |           | 6 mg/l, 23 °C       |                    | permitted     |
| Aniosteril D2M                            | June 2009 | 5%                  | Laboratoires Anios | permitted     |
| Aniosteril Contact                        | June 2009 | 1%                  | Laboratoires Anios | permitted     |
| Witty W4                                  |           | 2%, 23 °C, 4 h      |                    | permitted     |
| <b>Descaler</b>                           |           |                     |                    |               |
| DS-40                                     |           | 4%                  |                    | unpermitted   |
| Boiler noise protection                   |           | 0.20%               |                    | permitted     |
| Calcolith DP                              |           | 10%, 40 °C,<br>24 h |                    | permitted     |
| Calcolith TIN-BE                          |           | 5%, 80 °C, 24 h     |                    | permitted     |
| Household descalers (quick descalers)     |           | 20%                 |                    | permitted     |
| LS1                                       |           | 0.60%               |                    | permitted     |
| MB1                                       |           | 4%                  |                    | permitted     |
| Super Concentrate                         |           | 0.20%               |                    | permitted     |
| Superfloc                                 |           | 2%                  |                    | permitted     |
| <b>Cleaning agents</b>                    |           |                     |                    |               |
| Arkopal 110                               |           | 5%                  | Hoescht            | unpermitted   |
| ANTIKAL                                   |           | 100%                | P & G              | unpermitted   |
| BREF - Bathroom                           |           | 100%                | Henkel             | permitted     |
| BREF - Fresh shower                       |           | 100%                | Henkel             | permitted     |
| CAROLIN - gloss cleaner                   |           | 1.80%               | Boltom Belgium     | permitted     |
| CAROLIN - aktive fresh                    |           | 1.90%               | Boltom Belgium     | permitted     |
| CAROLIN - with linseed oil                |           | 1.90%               | Boltom Belgium     | permitted     |
| CAROLIN - Marseille soap                  |           | 1.80%               | Boltom Belgium     | permitted     |
| Meister Proper - lemon                    |           | 3.40%               | P & G              | not permitted |
| Meister Proper - Extra Hygiene            |           | 3.50%               | P & G              | permitted     |
| Meister Proper - sensitive surfaces       |           | 2.40%               | P & G              | unpermitted   |
| Meister Proper - orange peel              |           | 3.40%               | P & G              | unpermitted   |
| Meister Proper - winter fresh             |           | 3.40%               | P & G              | unpermitted   |
| TERRA - stone floors                      |           | 12%                 | Henkel             | permitted     |
| TERRA - parquet                           |           | 3.20%               | Henkel             | permitted     |
| TERRA - high gloss floors                 | June 2009 | 100%                | Henkel             | permitted     |

| Brand name   | Date       | Concentration | Manufacturer            | Use         |
|--|------------|---------------|-------------------------|-------------|
| <b>Seals</b>   |            |               |                         |             |
| Cimberio Loxeal 58 11 PTFE thread sealant                      |            | 100%          |                         | unpermitted |
| Dreibond 5331  |            | 100%, 23 °C   | Dreibond                | unpermitted |
| EPDM rubber O-ring   |            | 100%          | Join de France          | permitted   |
| Easyfit (Griffon)  | June 2009  | 100%          | Bison International     | unpermitted |
| Everseal pipe thread sealant                                   |            | 100%, 82 °C   | Federal Process Corp.   | unpermitted |
| FACOT PTFE SEAL (PTFE sealant)                                 |            | 100%          |                         | unpermitted |
| Filjoint   | June 2009  | 100%          | GEB                     | unpermitted |
| FILETPLAST EAU POTABLE   | June 2009  | 100%          | GEB                     | permitted   |
| GEBATOUT 2   | June 2009  | 100%          | GEB                     | permitted   |
| GEBETANCHE 82 (EX-GEB)   | June 2009  | 100%          | GEB                     | unpermitted |
| Griffon assembly kit   |            | 100%          | Verhagen-Herlitzius BV. | permitted   |
| Kolmat jointpaste (- 30 up to + 135 °C)                        |            | 100%          | Denso                   | permitted   |
| Locher Paste Special   |            | 100%          | Locher & Co AG          | permitted   |
| Loctite 5061   |            | 100%          | Loctite                 | permitted   |
| Loctite 518 seal eliminator                                    |            | 100%, 82 °C   | Loctite                 | unpermitted |
| Loctite 5331   | June 2009  | 100%          | Loctite                 | permitted   |
| Loctite 5366 silicomet AS-310                                  |            | 100%          | Loctite                 | permitted   |
| Loctite 542  |            | 100%, 23 °C   | Loctite                 | unpermitted |
| Loctite 55   | June 2009  | 100%          | Loctite                 | unpermitted |
| Loctite 572 thread sealant                                     | June 2009  | 100%, 60 °C   | Loctite                 | unpermitted |
| Loctite 577  |            | 100%, 23 °C   | Loctite                 | unpermitted |
| Loctite Dryseal  | Sep. 2008  | 100%          | Loctite                 | permitted   |
| Manta Tape   |            | 100%          |                         | permitted   |
| Multipak   |            | 100%          |                         | permitted   |
| Neo-Fermit   |            | 100%          | Nissen & Volk           | permitted   |
| Neo-Fermit Universal 2000                                      |            | 100%          | Nissen & Volk           | permitted   |
| Plastic Fermit - sealant                                       |            | 100%          | Nissen & Volk           | permitted   |
| Precote 4  |            | 100%          | Omnifit                 | unpermitted |
| Precote 80   |            | 100%          | Omnifit                 | unpermitted |
| RectorSeal # 5   |            | 100%, 82 °C   | RectorSeal Corp.        | unpermitted |
| Red Silicone Sealant (- 65 up to + 315 °C)<br>Silicone sealant |            | 100%          | Loctite                 | permitted   |
| Rite-Lok   |            | 100%          | Chemence                | unpermitted |
| Scotch-Grip Rubber & Seal Adhesive # 1300                      |            | 100%, 82 °C   | 3M                      | unpermitted |
| Scotch-Grip Rubber & Seal Adhesive # 2141                      |            | 100%, 82 °C   | 3M                      | unpermitted |
| Scotch-Grip Rubber & Seal Adhesive # 847                       |            | 100%, 82 °C   | 3M                      | unpermitted |
| Selet Unyte  |            | 100%, 82 °C   | Whitman                 | unpermitted |
| Tangit metalock  | Apr. 2007  | 100%          | Henkel                  | unpermitted |
| Tangit Racoretanche  | June 2009  | 100%          | Loctite                 | permitted   |
| Tangit Unilock   | June 2009  | 100%          | Henkel                  | unpermitted |
| TWINEFLO (PTFE band) + processing medium                       |            | 100%          | Resitape / Ulith        | permitted   |
| Twineflon  | March 2009 | 100%          | Unith                   | permitted   |
| Unipack  | May 2006   | 100%          |                         | unpermitted |
| Unipack Packsalve  |            | 100%          |                         | permitted   |
| Viscotex Locher Paste 2000                                     |            | 100%          |                         | permitted   |

## TECEflex - Annex

| Brand name   | Date       | Concentration | Manufacturer           | Use         |
|--|------------|---------------|------------------------|-------------|
| <b>Adhesive</b>                                      |            |               |                        |             |
| Atmosfix   | July 2009  | 100%          | Atmos                  | unpermitted |
| ARMAFLEX 520 ADHESIVE                                | Dec. 2008  | 100%, 50 °C   |                        | unpermitted |
| ARMAFLEX HT 625                                      | Dec. 2009  | 100%, 50 °C   |                        | unpermitted |
| BISON SILIKONENKIT SANITAIR                          |            | 100%          |                        | permitted   |
| Bison-Tix contact adhesive                           |            | 100%, 23 °C   | Perfecta International | unpermitted |
| CFS SILICONE SEALANT S-200 silicone sealant)         |            | 100%          |                        | permitted   |
| Colle Mastic hautes Performances                     | June 2009  | 100%          | Orapi                  | permitted   |
| Epoxy ST100  | July 2007  | 100%          |                        | unpermitted |
| GENKEM CONTACT ADHESIVE                              |            | 100%          |                        | unpermitted |
| GOLD CIRCLE SILICONEKIT BOUW TRANSPARENT             |            | 100%          |                        | permitted   |
| Knauf Sanitär Silicone Kit                           |            | 100%          |                        | permitted   |
| Knauf Silicone Kit for Acrylic                       | July 2009  | 100%          | Henkel                 | permitted   |
| Pattex colle rigide PVC                              |            | 100%          |                        | unpermitted |
| PEKAY GB480 (Vidoglue) adhesive                      |            | 100%          |                        | unpermitted |
| PEKAY GB685 (Insulglue) adhesive                     |            | 100%          |                        | permitted   |
| Repa R 200   |            | 100%          |                        | permitted   |
| RUBSON SILIKON SANITÄR TRANSPARENT SET               |            | 100%          | Rubson                 | permitted   |
| RUBSON SILIKON SANITÄR TRANSPARENT SET               |            | 100%          | Rubson                 | permitted   |
| Hydrophobic wood glue                                |            | 100%          |                        | permitted   |
| <b>Foams</b>   |            |               |                        |             |
| BISON PUR FOAM                                       | March 2009 | 100%          |                        | unpermitted |
| Boxer Mounting Foam                                  | Feb 2007   | 100%          |                        | unpermitted |
| Gunfoam - Winter - Den Braven East sp. z o.o.        | Feb 2007   | 100%          |                        | unpermitted |
| Gunfoam Proby  | Feb 2007   | 100%          |                        | unpermitted |
| Hercusal   | Feb 2007   | 100%          |                        | unpermitted |
| MODIPUR HS 539                                       | July 2009  | 100%          | Wickes                 | unpermitted |
| MODIPUR US 24 TEIL 2                                 | July 2009  | 100%          |                        | unpermitted |
| MODIPUR HS 539 / US 24 TEIL 2 (1/1)                  | July 2009  | 100%          |                        | unpermitted |
| PUR Foam (contains diphenylmethane-4,4-diisocyanate) |            | 100%          |                        | unpermitted |
| O.K. - 1 K PUR                                       |            | 100%          |                        | unpermitted |
| Omega Faum - foam                                    | Feb 2007   | 100%          |                        | unpermitted |
| Proby Mounting Foam                                  | Feb 2007   | 100%          |                        | unpermitted |
| PURATEC - 1 K PUR                                    |            | 100%          |                        | unpermitted |
| PURATEC - 2 K PUR                                    |            | 100%          |                        | unpermitted |
| Ramsauer PU foam                                     | July 2009  | 100%          |                        | unpermitted |
| Shaft and Well Foam Klima plus                       |            | 100%          |                        | unpermitted |
| Soudal Mounting Foam for low temperatures            | Feb 2007   | 100%          |                        | unpermitted |
| SOULDAL Gun Foam Soudalfoam -10                      | Feb 2007   | 100%          |                        | unpermitted |
| SOULDAL PU foam                                      | July 2009  | 100%          |                        | unpermitted |
| Door mounting foam 2-K Klima plus                    |            | 100%          |                        | permitted   |
| TYTAN Professional Gun Foam Winter                   | Feb 2007   | 100%          |                        | unpermitted |
| TYTAN Professional for PCV gun foam                  | Feb 2007   | 100%          |                        | unpermitted |
| TYTAN Professional Lexy 60 low-pressure              | Feb 2007   | 100%          |                        | unpermitted |
| TYTAN Euro-Line Mounting Foam                        | Feb 2007   | 100%          |                        | unpermitted |
| TYTAN Professional for PCV mounting foam             | Feb 2007   | 100%          |                        | unpermitted |



| Brand name                                 | Date      | Concentration          | Manufacturer   | Use         |
|--|-----------|------------------------|----------------|-------------|
| ZIMOWA SUPER PLUS - (mounting foam)        | Feb 2007  | 100%                   |                | unpermitted |
| <b>Greases</b>                             |           |                        |                |             |
| BAYSILONE OIL M 1000                       |           | 100%                   |                | permitted   |
| BECHEM BERUSOFT 30                         |           | 100%                   | bechem         | permitted   |
| Bechem Berulube Sihaf 2                    | May 2008  | 100%                   | bechem         | permitted   |
| Dansoll Silec Blue Silicone Spray          |           | 100%                   | dansoll        | permitted   |
| Dansoll Super Silec Sanitär mounting paste |           | 100%                   | dansoll        | permitted   |
| Huile de chenevis                          |           | 100%                   |                | permitted   |
| Kluber Proba 270                           |           | 100%                   | Kluber         | permitted   |
| Kluber Paralig GTE 703                     |           | 100%, 80 °C,<br>96 h   | Kluber         | permitted   |
| Kluber Syntheso glep1                      |           | 100%, 135 °C,<br>120 h | Kluber         | unpermitted |
| KLÜBERSYNTH VR 69-252                      |           | 100%                   | Kluber         | permitted   |
| Kluber Unislikikone L641                   |           | 100%                   | Kluber         | permitted   |
| Kluber Unislikikone TKM 1012               |           | 100%, 80 °C,<br>96 h   | Kluber         | permitted   |
| OKS 462 / 0956409                          |           | 100%                   | Kluber         | permitted   |
| OKS 477 VALVE GREASE                       |           | 100%                   | Kluber         | permitted   |
| Laureat Zloty Installator                  |           | 100%                   |                | permitted   |
| Luga Spray (Leif Koch)                     |           | 100%                   | Leif Koch      | permitted   |
| Rhodorsil 47 V 1000                        |           | 100%, 80 °C,<br>96 h   |                | permitted   |
| SiliKon Spray (Motip)                      |           | 100%                   | Motip          | permitted   |
| silicona lubricante SDP ref S-255          |           | 100%                   |                | permitted   |
| Silicone oil M 10 - M 100000               |           | 100%                   |                | permitted   |
| Silicone oil M 5                           |           | 100%                   |                | permitted   |
| Turmisilon GL 320 1-2                      |           | 100%                   |                | permitted   |
| UNISILIKON L250L                           | June 2008 | 100%                   |                | permitted   |
| Wacker silicone                            |           | 50%, 95 °C,<br>96 h    | Wacker         | unpermitted |
| <b>Metals</b>                              |           |                        |                |             |
| Copper ions (Cu 2+)                        |           | 50 ppm                 |                | permitted   |
| Solder flux S 39                           | June 2009 | 100%                   |                | permitted   |
| Solder flux S 65                           | July 2009 | 100%                   |                | unpermitted |
| YORKSHIRE FLUX                             |           | 100%                   |                | unpermitted |
| Degussa Degufit 3000                       |           | 100%                   | Degussa        | permitted   |
| Aluminium ions (Al 3+)                     |           | 50 ppm                 |                | permitted   |
| Atmosflux                                  | July 2008 | 100%                   |                | permitted   |
| <b>Paint</b>                               |           |                        |                |             |
| Sigma Superprimer TI                       |           | 100%                   | Sigma Coatings | permitted   |
| Sigma Amarol                               |           | 100%                   | Sigma Coatings | permitted   |
| Decalux                                    |           | 100%                   | De Keyn Paint  | permitted   |
| Permaline                                  |           | 100%                   | ITI-Trimetal   | permitted   |
| Silvatane                                  |           | 100%                   | ITI-Trimetal   | permitted   |
| DULUX water-based high-gloss paint         |           | 100%                   | ICI            | unpermitted |
| DULUX water-based silky gloss paint, satin |           | 100%                   | ICI            | unpermitted |
| DULUX for microporous wood, silky gloss    |           | 100%                   | ICI            | permitted   |
| DULUX floor paint, very tough, silky gloss |           | 100%                   | ICI            | permitted   |

## TECEflex - Annex

| Brand name   | Date      | Concentration | Manufacturer | Use         |
|--|-----------|---------------|--------------|-------------|
| DULUX metal paint, anti-corrosive, high gloss                    |           | 100%          | ICI          | permitted   |
| Hammerite white, silky gloss                                     |           | 100%          | ICI          | permitted   |
| Hammerite white, high gloss, based on Xyleen                     |           | 100%          | ICI          | unpermitted |
| Hammerite silver-grey high gloss, based on Xyleen                |           | 100%          | ICI          | permitted   |
| Boss Satin   |           | 100%          | BOSSPAINTS   | permitted   |
| Hydrosatin Interior  |           | 100%          | BOSSPAINTS   | permitted   |
| Carat  |           | 100%          | BOSSPAINTS   | permitted   |
| Bolatex  |           | 100%          | BOSSPAINTS   | permitted   |
| Optiprim   |           | 100%          | BOSSPAINTS   | permitted   |
| Elastoprim   |           | 100%          | BOSSPAINTS   | permitted   |
| Plastiprop   |           | 100%          | BOSSPAINTS   | unpermitted |
| Formule MC   |           | 100%          | BOSSPAINTS   | unpermitted |
| MAPEGRUNT  |           | 100%          | Mapei        | permitted   |
| DULUX PRIMER   |           | 100%          | ICI          | permitted   |
| UNI-GRUNT  |           | 100%          | Atlas        | permitted   |
| <b>Wall filler and construction products</b>                     |           |               |              |             |
| Bituperl (insulating filler with bitumen)                        |           | 100%          |              | permitted   |
| Insulating coat with bitumen                                     |           | 100%          |              | permitted   |
| Cold adhesive for bitumen paper                                  |           | 100%          |              | permitted   |
| Climacoll adhesive for pipe insulation foam                      |           | 100%          |              | unpermitted |
| Compactuna   |           | 6%            |              | permitted   |
| FERROCLEAN 9390  | Feb 2008  | 100%          |              | permitted   |
| FT-extra   |           | 100%          |              | permitted   |
| Giso base primer   |           | 100%          |              | unpermitted |
| KNAUF STUC PRIMER  | July 2009 | 100%          |              | permitted   |
| Mellerud mould killer  |           | 100%          |              | permitted   |
| Mineral wool insulation with blocking layer against metal vapour | July 2007 | 100%          |              | unpermitted |
| Nivoperl (insulating filler)                                     |           | 100%          |              | permitted   |
| PCI LASTOGUM   | Feb 2008  | 100%          |              | permitted   |
| PCI Seccoral 1K  | Feb 2008  | 100%          |              | permitted   |
| Perfax Rebouche tout   | July 2009 | 100%          |              | permitted   |
| PE pipe insulation foam  |           | 100%          |              | permitted   |
| Polyfilla inner wall filler                                      |           | 100%          | Polyfilla    | permitted   |
| Porion immediate trowel  |           | 100%          | Henkel       | permitted   |
| Porion mortar for repairs  |           | 100%          | Henkel       | unpermitted |
| Portland Cement - cement   |           | 100%          | CBR          | permitted   |
| RIKOMBI KONTAKT (RIGIPS)   |           | 100%          |              | permitted   |
| Self-adhesive insulation PE foam (wrapping tape)                 |           | 100%          |              | unpermitted |
| SOPRO FDH 525 (liquid foil)                                      | Sep. 2008 | 100%          |              | permitted   |
| Stucal Putz  |           | 100%          | Gyproc       | permitted   |
| TANGIT REINIGER  | July 2007 | 100%          |              | unpermitted |
| TANGIT special cleaner   | July 2007 | 100%          |              | permitted   |
| Tile adhesive  |           | 100%          |              | permitted   |
| Universal primer   |           | 100%          |              | permitted   |
| Wood-concrete Multiplex Bruynzeel (moisture from...)             |           | 100%          |              | unpermitted |
| Wood pint (moisture from...)                                     |           | 100%          |              | unpermitted |

| Brand name   | Date       | Concentration          | Manufacturer | Use         |
|--|------------|------------------------|--------------|-------------|
| Wood MDF medium density fibreboard (moisture from...)        |            | 100%                   |              | unpermitted |
| Wood Multiplex sealed watertight (moisture from...)          |            | 100%                   |              | unpermitted |
| <b>Anti-Termite</b>  |            |                        |              |             |
| Aripyreth Oil Solution                                       |            | 100%, 23 °C            |              | permitted   |
| Baktop MC  |            | 100%, 23 °C            |              | permitted   |
| Ecolofen CW  |            | 100%, 23 °C            |              | permitted   |
| Ecolofen Emulsifiable Concentrate - emulsifiable concentrate |            | 100%, 23 °C            |              | permitted   |
| Ecolofen Oil Solution - oil solution                         |            | 100%, 23 °C            |              | permitted   |
| Grenade MC   |            | 100%, 23 °C            |              | permitted   |
| Hachikusan 20WE/AC   |            | 100%, 23 °C            |              | permitted   |
| Hachikusan FL  |            | 100%, 23 °C            |              | permitted   |
| Kareit Oil Solution - oil solution                           |            | 100%                   |              | permitted   |
| Rarap MC   |            | 100%, 23 °C            |              | permitted   |
| <b>Corrosion inhibitors</b>                                  |            |                        |              |             |
| BAYROFILM T 185  |            | 0.30%                  |              | permitted   |
| Copal corrosion inhibitor                                    | April 2007 | 100%                   |              | permitted   |
| KAN-THERM  | Sep. 2008  | 100%                   |              | permitted   |
| INIBAL PLUS  | Sep. 2008  | 100%                   |              | permitted   |
| NALCO VARIDOS 1PLUS1   | Jan 2009   | 2%,<br>23 & 95 °C      |              | permitted   |
| <b>Gas leak sprays</b>                                       |            |                        |              |             |
| LIQUI MOLY leak seeker spray                                 |            | 100%, 23 °C            |              | permitted   |
| Multitek gas leak spray                                      |            | 100%                   |              | unpermitted |
| Sherlock gas leak detector                                   |            | 100%                   |              | permitted   |
| Ulith leak detector spray                                    | Sep. 2008  | 100%                   |              | permitted   |
| LECK-SUCH-SPRAY 400ML (ART. 3350)                            | Jan 2009   | 100%,<br>23 °C & 95 °C |              | permitted   |
| LECK-SUCH-SPRAY 400ML (ART. 1809)                            | Jan 2009   | 100%,<br>23 °C & 95 °C |              | permitted   |
| LECKSUCHER PLUS (ART. 890-27)                                | Jan 2009   | 100%,<br>23 °C & 95 °C |              | permitted   |
| LECKSUCHER 400 ML (ART. 890-20)                              | Jan 2009   | 100%,<br>23 °C & 95 °C |              | permitted   |
| LECKSUCHERSPRAY ROTEST                                       | Jan 2009   | 100%,<br>23 °C & 95 °C |              | permitted   |
| GUPOFLEX LEAK-SEEKER (ART 301) leak seeker                   | Jan 2009   | 100%,<br>23 °C & 95 °C |              | permitted   |
| LECKSUCHER 5 L (ART 4120)                                    | Jan 2009   | 100%,<br>23 °C & 95 °C |              | permitted   |
| GUEPO LEAK-SEEKER ETL (ART 121) leak seeker                  | Jan 2009   | 100%,<br>23 °C & 95 °C |              | permitted   |
| GUEPO LEAK-SEEKER SOAPLESS (ART 131) soapless leak seeker    | Jan 2009   | 100%,<br>23 °C & 95 °C |              | permitted   |
| GASLEAK DETECTOR (GRIFFON)                                   | June 2009  | 100%, 60 °C            |              | permitted   |
| GASLEAK DETECTOR KZ gas leak detector                        | June 2009  | 100%, 60 °C            |              | permitted   |

The information in this table has been compiled to the best of our knowledge and is intended as general information. The results in the table show typical average values from a representative number of individual measurement results. These values should in no way be seen as specifications. Furthermore, TECE assumes no responsibility for the use of products not contained in this list.



All data contained in the Technical Guidelines has been compiled with the utmost care. The correctness of the data presented cannot be guaranteed, however. TECE assumes no liability for damages resulting from the use of this information. Text and images are protected by copyright law.

© Copyright 2018, TECE GmbH, Hollefeldstraße 57, 48282 Emsdetten, Germany

