

TECHNICAL GUIDELINES

SANITARY SYSTEMS



TECE:

Intelligente Haustechnik

TECE International

Austria

TECE Österreich GmbH

Lichtäckerstraße 22
A - 2522 Oberwaltersdorf
Phone: +43 2253 211 78
Fax: +43 2253 211 78 20
info@tece.at
www.tece.at

Belarus

IOOO TECE

Shchomyslitsa Soviet, Agogorodok,
Ozertso, House 31, office 19
BY - 223049 Minsk region
Phone: +375 17 507 51 90
Fax: +375 17 507 51 91
info@teceby.by
www.teceby.by

Belgium

TECE Belgium BVBA

Kievitplein 20/C12
B - 2018 Antwerpen
Phone: +32 2 401 61 37
Fax: +32 2 401 61 38
info@tece.be
www.tece.be

China

Suzhou TECE Plumbing Ltd.

Room G, Floor 7
ShengQuan Business Center No. 28
Tanjiadu Road, Putuo District
CN - 200063 Shanghai
Phone: +86 21 32555030
Fax: +86 21 32555021
info@tece.cn
www.tece.cn

Croatia

TECE d.o.o.

Fallerovo šetalište 16
HR - 10000 Zagreb
Phone: +38 513 079 000
Fax: +38 513 079 048
info@tece.hr
www.tece.hr

Czech Republic

TECE Česká republika, s.r.o.

Prosecká 852/66
CZ - 190 00 Praha 9 - Prosek
Phone: +420 266 107 226
Fax: +420 266 107 228
info@tece.cz
www.tece.cz

Estonia

UAB TECE BALTIKUM Eesti filiaal

Mere pst. 8
EST - 10111 Tallinn
Phone: +372 6 781100
info@tece.ee
www.tece.ee

France

TECE France S.A.R.L.

5 rue Jean Rostand
F - 69740 Genas
Phone: +33 437 453 810
Fax: +33 437 454 110
info@tece.fr
www.tece.fr

Germany

TECE GmbH

Hollefeldstraße 57
D - 48282 Emsdetten
Phone: +49 2572 928 0
Fax: +49 2572 928 124
info@tece.de
www.tece.de

India

TECE India Private Ltd.

G-3, Neel Madhav,
Nr. Navneet Hospital,
V.P. cross road, Mulund (west),
IND - Mumbai Maharastra 400080
Phone: +91 (22) 21676755
Fax: +91 (22) 21676707
info@tece.in
www.tece.in

Italy

TECE Italia s.r.l.

Via dell'Industria, 24 A
I - 41051 Castelnovo Rangone (MO)
Phone: +39 0 595 334 011
Fax: +39 0 595 334 010
info@teceitalia.com
www.tece.it

Latvia

UAB TECE Baltikum Latvia

Makusalas iela 41B-8
LV - 1004 Ryga
Phone: +371 67 21 18 02
Fax: +371 67 21 18 05
info@tece.lv
www.tece.lv

Lithuania

UAB TECE Baltikum

Terminalo g. 10
Biruliškių km. Kauno raj.
LT - 54469 Lithuania
Phone: +370 37 314 078
Fax: +370 37 313 084
info@tece.lt
www.tece.lt

Netherlands

TECE Nederland GmbH

W.A. Scholtenweg 7 a
NL - 9422 BR Smilde
Phone: +31 592 415 074
Fax: +31 592 414 628
info@tece-nederland.nl
www.tece-nederland.nl

Norway

PROBATA AS

Kveldroveien 19
N - 1407 Vinterbro
Phone: +47 66 82 33 00
Fax: +47 66 82 33 30
post@probata.no
www.probata.no

Poland

TECE Sp. z o.o.

Wroclawska 61
PL - 57-100 Strzelin
Phone: +48 713 839 100
Fax: +48 713 839 101
tece@tece.pl
www.tece.pl

Romania

TECE Romania SRL

Soseaua de Centura, No. 13a
RO - 077040 Chiajna, Ilfov
Phone: +40 21 203 47 08
Fax: +40 31 030 47 10
info@tece.ro
www.tece.ro

Russia

OOO TECE Systems

Ul. Zentralnaja
Goljevo - Ul. Centralnaja 3
RUS - 143493 Moscow
Phone: +7 495 988 07 94
Fax: +7 495 988 07 95
info@tece.ru
www.tece.ru

Spain

TECE Haustechnik, S.L.

Enrique Mariñas, 28 bajo
E - 15009 A Coruña
Phone: +34 881 89 50 25
Fax: +34 881 89 50 26
info@tece.es
www.tece.es

Switzerland

TECE Schweiz AG

Gewerbestrasse 8
CH - 8212 Neuhausen am Rheinfall
Phone: +41 52 672 62 20
Fax: +41 52 672 62 21
info@tece.ch
www.tece.ch

Ukraine

TOV TECE Ukraine

Williamsa Akademika str. 3/7, of.7
UA - 03191 Kyiv
Phone: +38 044 596 59 46
Fax: +38 044 596 59 47
info@tece.ua
www.tece.ua

	Page
Flushing Technology	
<u>TECEprofil – the tried-and-tested prewall system with TECE flushing technology</u>	5
<u>TECEbox – the tried-and-tested technology for brick-wall construction</u>	61
<u>TECE flushing technology – the innovative technology with a system</u>	75
<u>TECE push plates – the collection for toilet and urinal</u>	95
<u>TECElux toilet terminal – the toilet of the future</u>	169
Drain Technology	
<u>TECEDrainline – the flush-level shower with a system</u>	199
<u>TECEDrainpoint S – the range of floor drains made of plastic</u>	251
<u>TECEDrainboard – the solid foundation for flush-level showers</u>	279

References to standards and installation recommendations are based on standards and building regulations currently applicable in Germany. Different or supplementary regulations may apply in other countries. Observe all local regulations.



TECEprofil – dry-wall construction
Technical Guidelines

TECEprofil dry-wall construction system	8
System description	9
Fields of application	9
Cost effectiveness	10
System installation / rules	11
Standard heights of installation walls	11
Standard applications	11
Building a supporting frame with module installation	16
Covering with plasterboard	17
Filling of plasterboard panels	19
Panelling for very wet areas	20
Possible pre-wall heights and depths	22
Limits	23
Protection against moisture	23
Floor fixing	23
Equipotential bonding	23
Cantilever loads	24
TECEprofil – Universal module	25
Installation in a TECEprofil pre-wall	25
Installation in front of a solid wall	26
Installation in a room height C-profile steel post-and-beam wall	29
Installation in room height steel post-and-beam wall with UA-profiles	30
Installation in a wooden post-and-beam wall	31
Securing individual modules to the floor	31
Toilet module with connection for odour extraction	32
Individual or module construction	34
TECEprofil bathtub assembly	35

Washlet solutions	38
TOTO Neorest washlet	38
Upgrade set for wall-hung washlet	38
Washlet attachments	39
Barrier-free construction with TECEprofil	40
Planning fundamentals	40
Barrier-free WC system in a TECEprofil wall	41
Barrier-free toilet system in individual construction	42
TECEprofil Geronto module	42
Sound insulation	45
Relevant standards	45
TECEprofil noise-protection verification	48
TECEprofil dry-wall construction system - sound insulation according to DIN 4109	53
TECEbox brick-wall construction system - sound insulation according to DIN 4109	57
Fire protection	59
TECEprofil room-dividing walls with fire protection requirements	59
Construction of a dividing wall (F 30 – F 120)	59

TECEprofil – dry-wall construction system

TECEprofil dry-wall construction system

TECEprofil is a pre-wall system that has proved its value over many years, and can be used to create bathroom walls quickly and effectively. The plumber not only produces the sanitary and heating installations, but working alone with TECEprofil he is also able to provide complete bathrooms with surfaces ready for tiling.

TECEprofil is a dry-wall construction system which, because of its flexibility, is particularly suitable for renovation of older buildings. Because of the time and cost savings compared with bricked-in pre-walls, the TECEprofil system is also of interest for new builds. The design freedom of the TECEprofil system allows the installer to realise unconventional bathrooms and offers generous scope for creative ideas.



Bathroom walls with TECEprofil – before



Bathroom walls with TECEprofil – after

The TECEprofil system offers universal modules for popular applications. These modules not only simplify installation in a TECEprofil wall, but they also can be used for conventional dry-wall constructions and as individual modules.

The TECEprofil system basically consists of the supporting frame, the universal modules and the TECEprofil system facing. The supporting frame is based on a profiled tube which is connected with corner joints. The complete supporting frame is installed on the structural shell using double brackets or angle brackets.

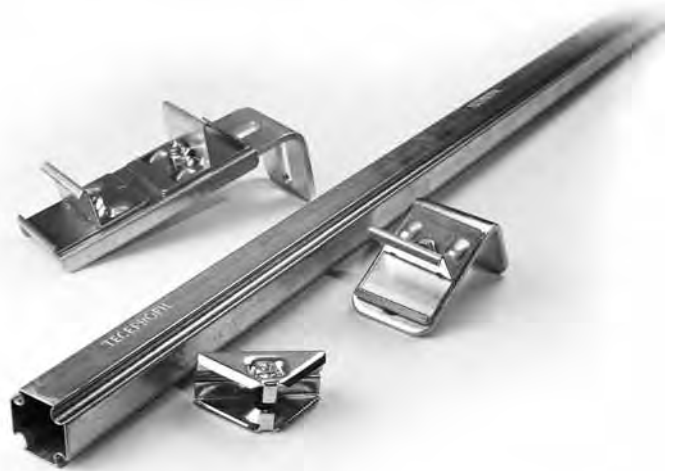

The four components of the TECEprofil system:

- double bracket
- profiled tube
- angle bracket
- corner joint

Special features of the TECEprofil system:

- clear range with only four basic components
- generous dimension tolerance when cutting the profiled tube to length
- stable and safe fixing technology
- clean and fast installation
- highly versatile TECEprofil universal modules
- installation without special tools
- price advantages when considering the overall cost

System description

The TECEprofil system is equally suitable for new build and renovation of older buildings. Because of its universality, the TECEprofil system is ideal for difficult building situations, such as sloping ceilings or wall recesses.

The TECEprofil supporting frame is variable and extremely stable.

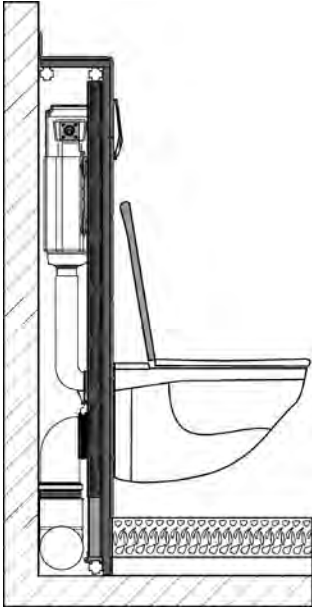

**One of the many advantages:
A pre-wall is part of the dwelling area**

A particular advantage is that a pre-wall is added to the net floor space of the room. According to section 2.3 of DIN 277, exposed installations and other shelf surfaces also belong to the net floor space. According to the "Second Calculation Directive (II. BV)", wall structures do not need to be subtracted when rooms are measured (II. BV, § 43, section 2). A pre-wall is therefore living space! It can therefore be fully taken into account during calculation of dwelling area.

Fields of application

Pre-wall installation

Pre-walls are becoming more and more popular in bathrooms. They offer additional shelf space and make installation of the sanitary items far easier.

Free-standing installation wall

Free-standing installation walls are erected anywhere in the room. They can be implemented at partial height or room height. Free-standing walls must be firmly attached to the unfinished floor. Assembly onto the finished floor is not possible. Walls which project freely into the room must be additionally secured with a "Support foot for free-standing walls".

Dividing walls

The TECEprofil system enables room height dividing walls to be created. In this way for instance, an existing room can be divided into separate toilets for men and women. The dividing wall can be directly equipped with WC modules or washbasins. The construction is according to DIN 4103.

Duct covering

The TECEprofil system allows all types of duct to be covered. Combination of installation walls and ducts is also possible.

Shelf heights

Practically all shelf heights are possible. The standard universal modules permit a minimum supporting frame height of 1150 mm. The WC universal modules for low construction heights have a minimum supporting frame height of 980 or 820 mm. For the universal modules, the TECEprofil range offers the facility to create an upwardly variable, stepless adjustable supporting frame height using telescopic fixing (Order No. 9 380 001) or a height-adjustable module fixing (Order No. 9 380 002).

TECEprofil – dry-wall construction system

Cost effectiveness

In order to substantiate the savings with a pre-wall made using TECEprofil in dry-wall construction compared with a bricked-in pre-wall, the Münster Chamber of Handicrafts compared the two construction methods and rated them.

Task

Creation of a sanitary installation up to the tileable surface.

Conditions

Two craftsmen (master craftsman or journeyman and apprentice) each in two prepared installation boxes work in brick-wall construction or dry-wall construction under the same conditions.



Brick-wall construction(left) compared with dry-wall construction

Because brick-wall construction can only be worked in stages over several days, extra boxes were provided for these two, in which the stages were prepared with the required state of dryness. In addition, the brick-wall construction received support from a "block laying gang".

Evaluation

The technical director of the German Central Association for Sanitation, Heating and Air Conditioning, Franz-Josef Heinrichs, and the head of department of supply engineering at the Münster Chamber of Handicrafts Vocational Training Centre (HBZ), Rudolf Mlynek ensured that the applicable standards, rules and regulations were adhered to. Legal expert Andrea Saabe from the HBZ Münster monitored the comparability of the conditions of the event. A neutral time and motion expert recorded the times.



Completed sanitary installation

Result

An installation created using TECEprofil is about 20 % cheaper than a bricked-in pre-wall. Three trades were involved with the bricked-in pre-wall (plumber, bricklayer, plasterer). The dirtiness rating in brick-wall construction is considerably greater than with a TECEprofil wall. This arose from a single source. With a TECEprofil wall, coordination between the trades is not necessary. The plumber increases his turnover considerably by the creation of a complete pre-wall.

Dry-wall construction with TECEprofil	brick-wall construction with customary materials
Complete TECEprofil pre-wall WC module pre-wall, profiled tube Accessories 557.23 € Drainage installation 107.51 € Potable water installation 93.43 €	Sanitary installation Material: for WC & basin 244.00 € Drainage installation 204.10 € Potable water installation 127.54 €
Labour costs: 3 hr. 31 min. each journeyman & apprentice plus 0.5 hr. travelling 226.00 €	Labour costs: 1 hr. 51 min. each journeyman & apprentice plus 0.5 hr. travelling 129.82 €
	Sanitary equipment walling Building materials 168.80 €
	Labour costs: 3 hr. 24 min. each journeyman & apprentice plus 0.5 hr. travelling 226.00 €
	Tileable surface Material and labour 153.23 €
Total cost 984.17 €	Total cost 1253.50 €

Cost comparison – dry-wall construction and brick-wall construction

System installation / rules

During installation of a TECEprofil wall for sanitary equipment, minimum distances apart for struts and fixings must be adhered to. In the following sections, the guidelines for installation of the system will be explained.

Standard heights of installation walls

The standard supporting frame height of a TECEprofil pre-wall is 1150 mm. This produces a WC seat height of 430 mm.

Tip:
For reasons of comfort, we recommend a seat height of 450 mm. The height of the supporting frame in this case is 1170 mm. In order to guarantee secure fixing of panelling, a horizontal

TECEprofil strut must be built in at least every 650mm.

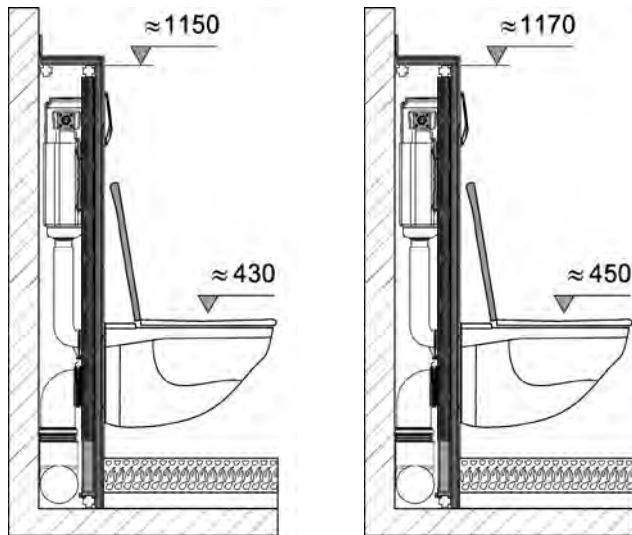

WC seat height: Standard (left) and comfort

The dimensions of the TECE panelling are 625 x 1350 x 18 mm. The maximum floor buildup is 200 mm.

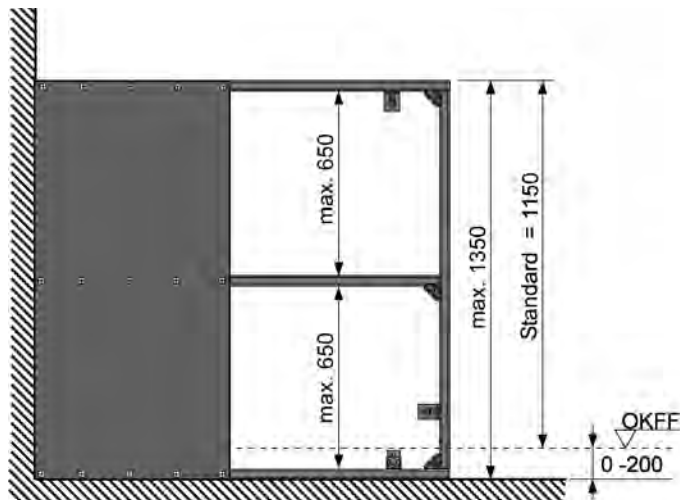

Dimensions of the facing sheets

For ease of installation, all universal modules have a meter line stamped on them.

Standard applications

In front of a solid wall

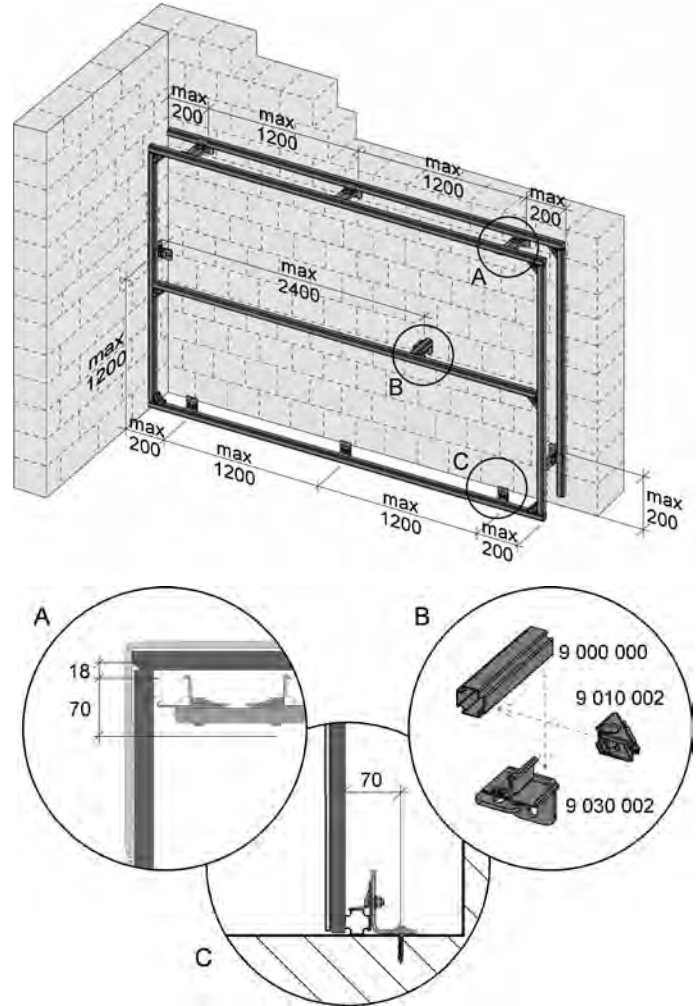

Profile wall in front of a solid wall

The separation of the fixings on the structural shell is a maximum of 1.2 m. The first wall, floor or ceiling fixing must be no less than 20 cm from the edge of the pre-wall.

Dry stud partition

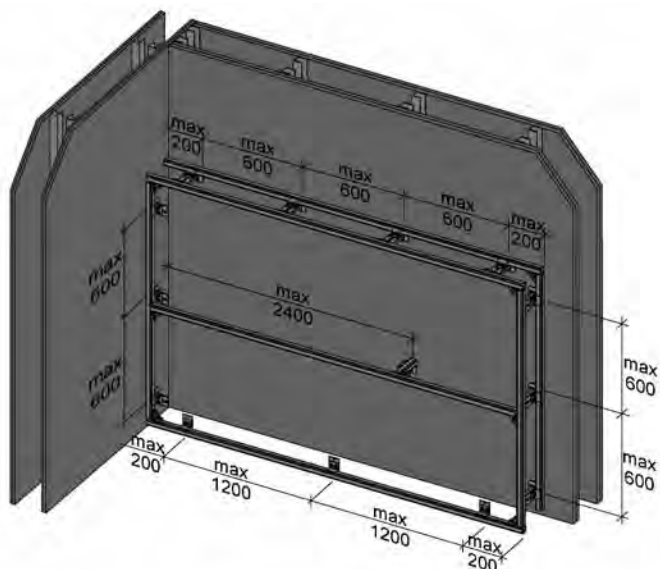

Dry stud partition

TECEprofil installation walls can be set up in front of a dry stud partition. The stud partition must have been erected in accordance with DIN 18183.

The metal stud partition substructure must have been

constructed in sheet steel profiles to DIN 18180/T1.

The minimum profile size is CW 75 x 50 x 6 mm for simple

stud partition and CW 50 x 50 x 6 mm for supported double stud

partition.

The metal stud partition must be panelled with 12.5 mm thick panels on both sides. The minimum fixing spacing is 60 cm.

Room height installation wall

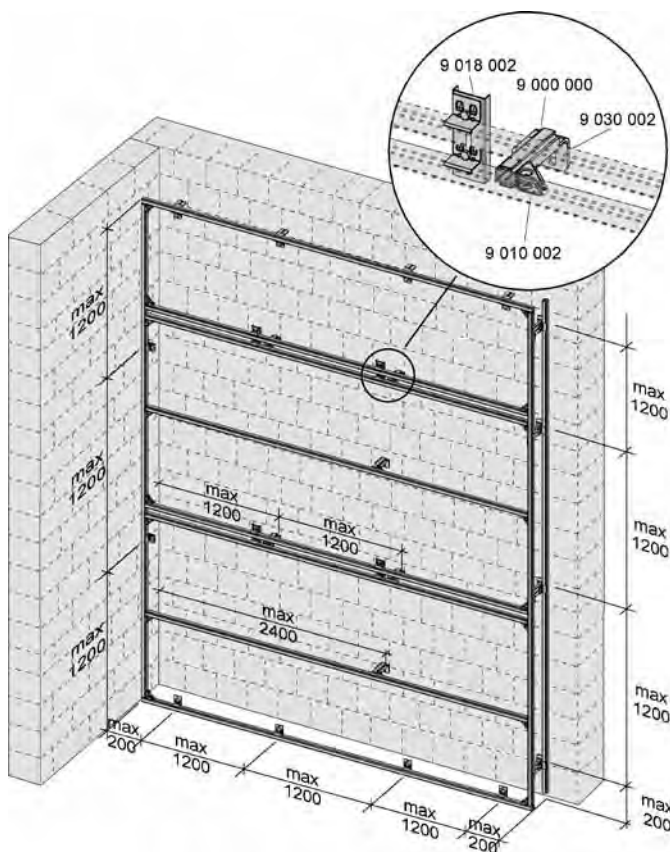

Installation wall, room height

Double struts are required for panelling. These must be fixed together at least every 1.2m. They should also be additionally supported by the wall behind.

Adjacent duct / pipe covering

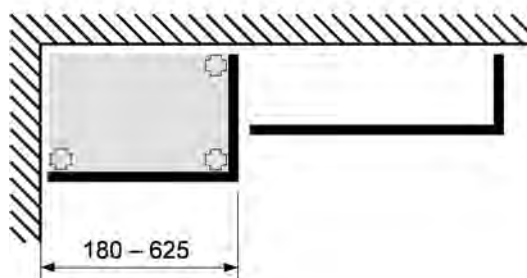

Fitted duct

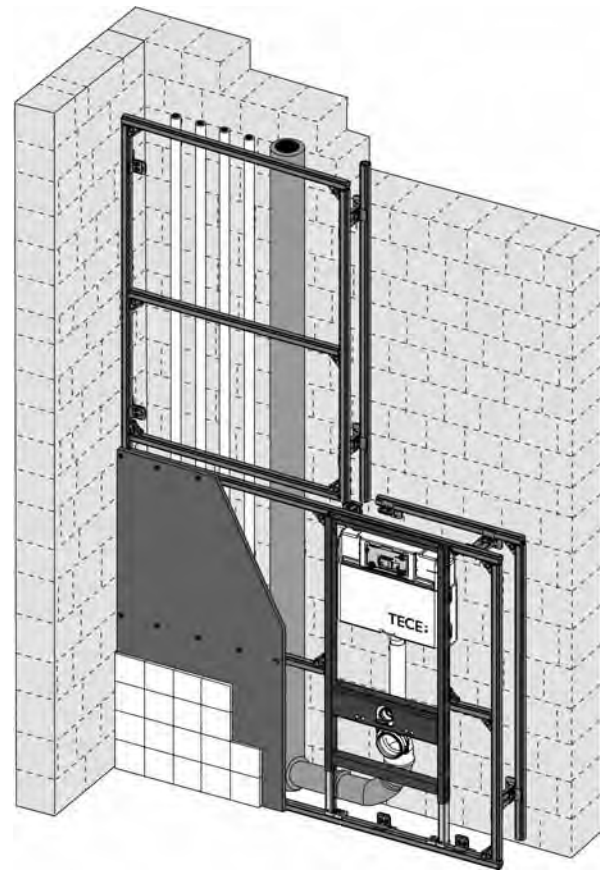
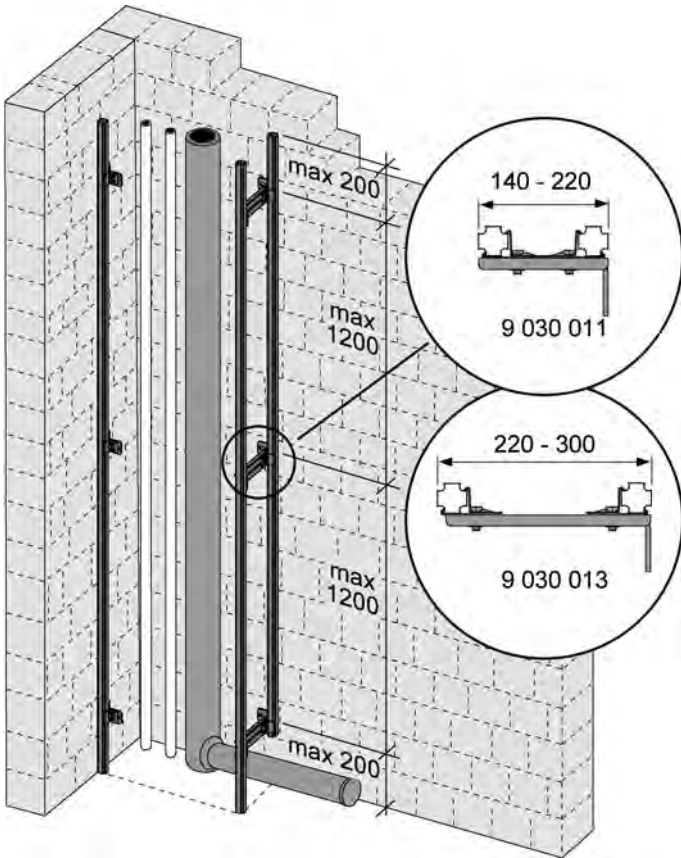
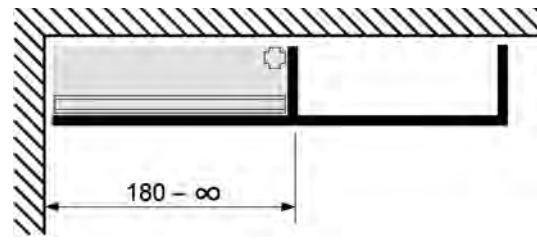

Fitted duct

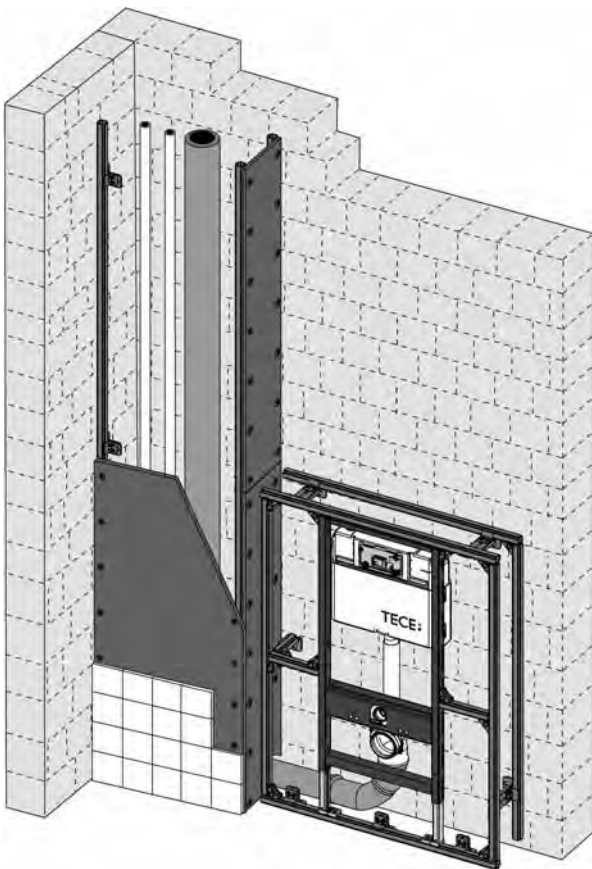

Adjacent duct, pipe covering

TECEprofil – system installation instructions

Free-standing wall, abutted on one side

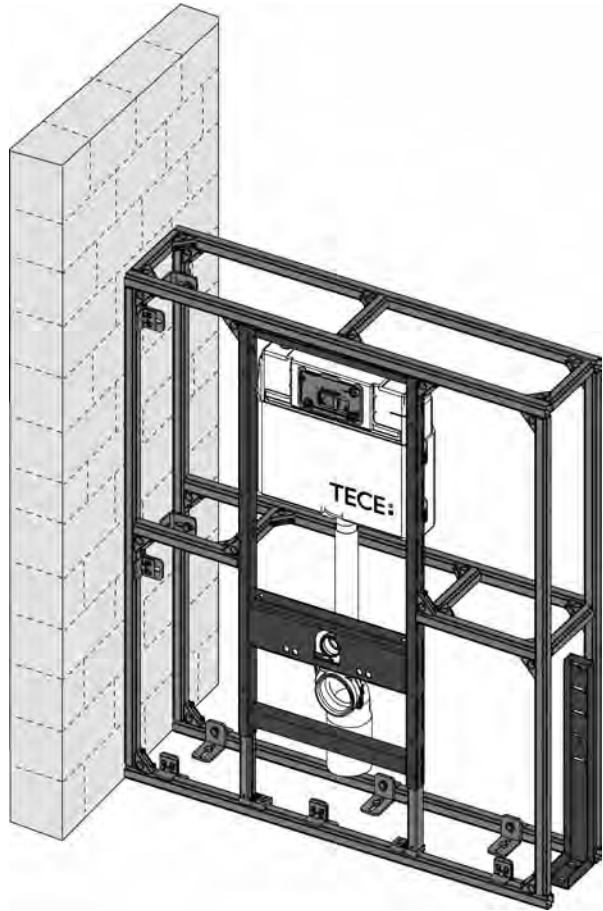
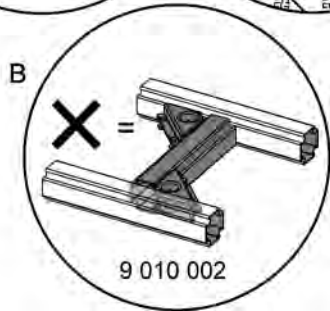
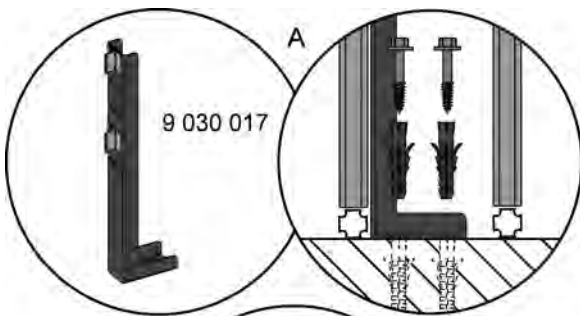
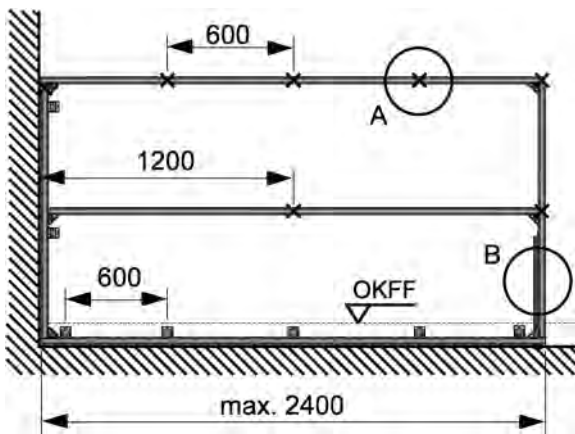

Free-standing wall, abutted on one side

Free-standing wall, abutted on both sides

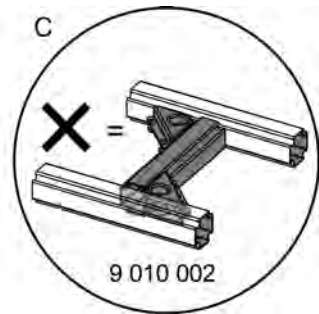
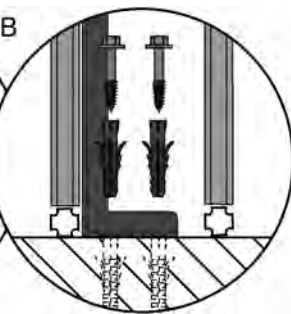
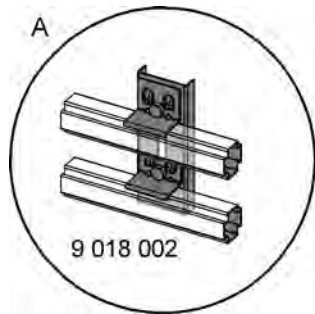
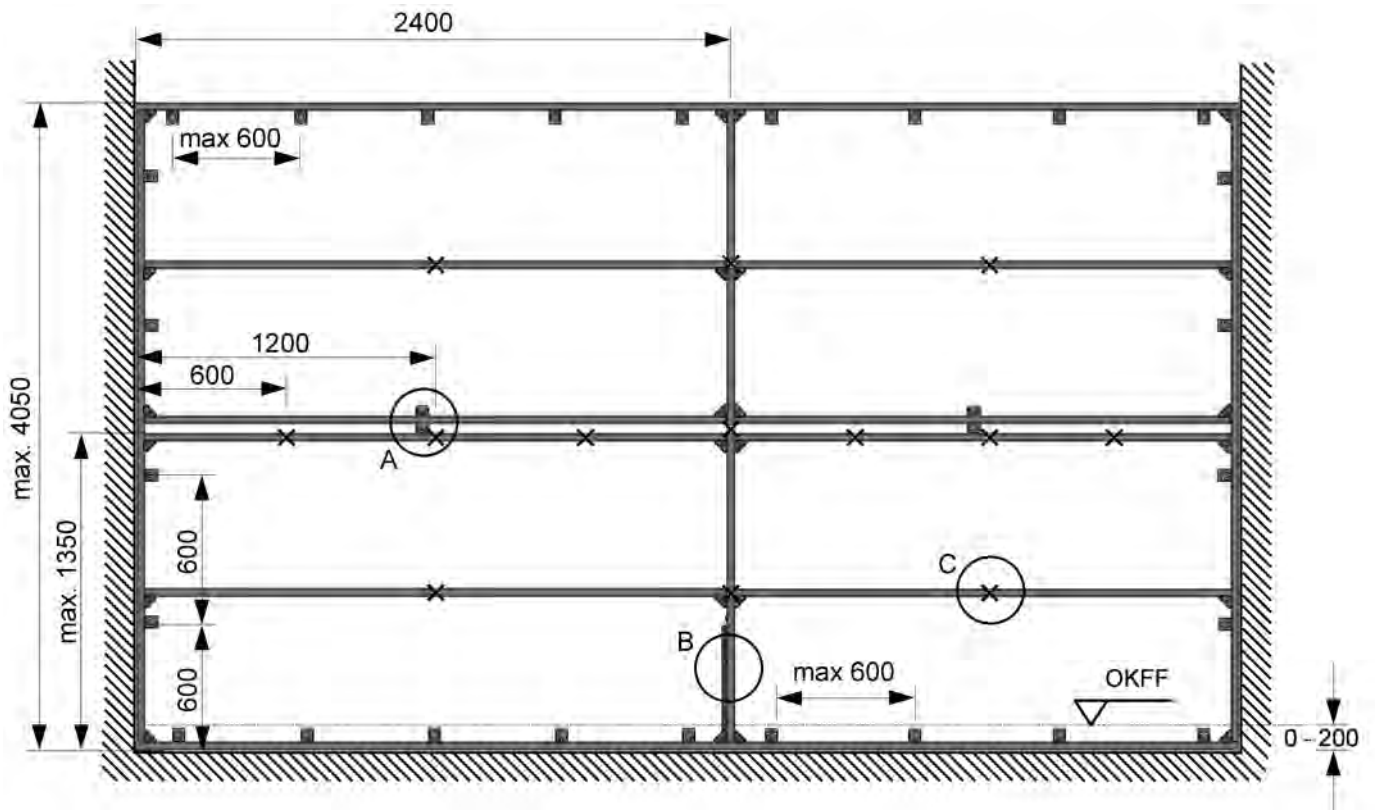

Free-standing wall, abutted on both sides

Building a supporting frame with module installation

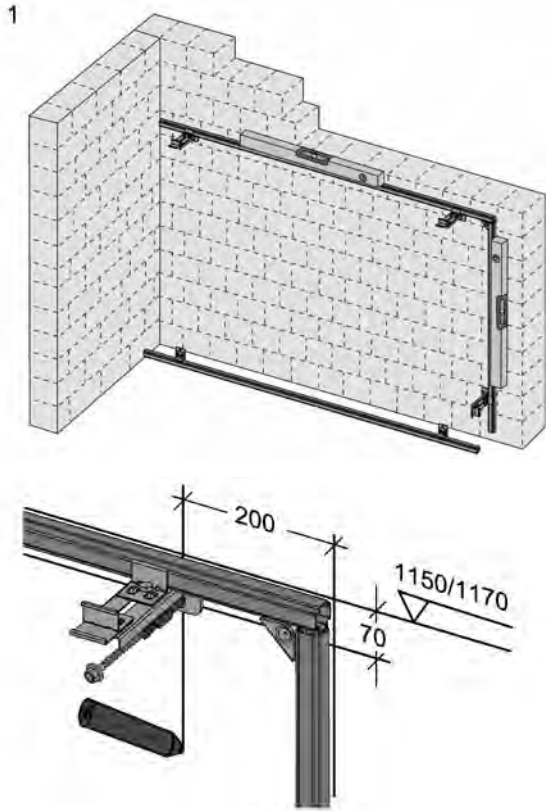

Secure the profiled tube to the wall with double brackets, to the floor with angle brackets

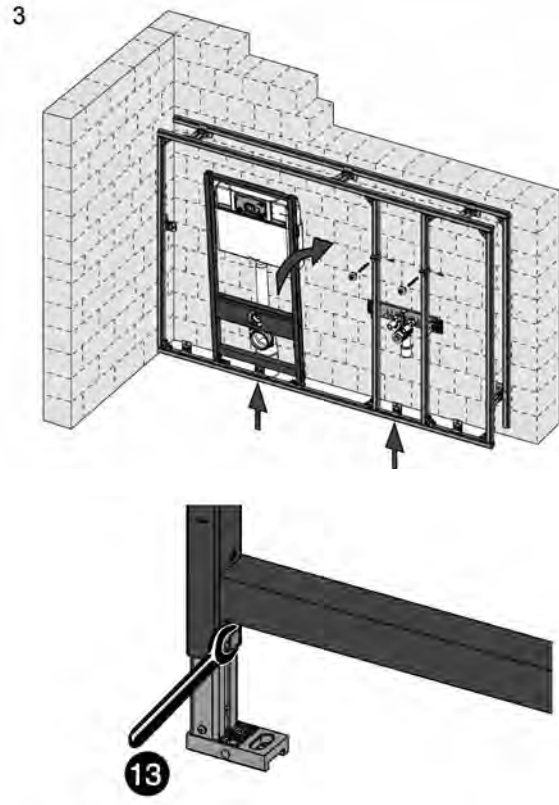

Place the angle bracket centred on the module or crossbeam, put the module feet onto the profiled tube, release the foot brake

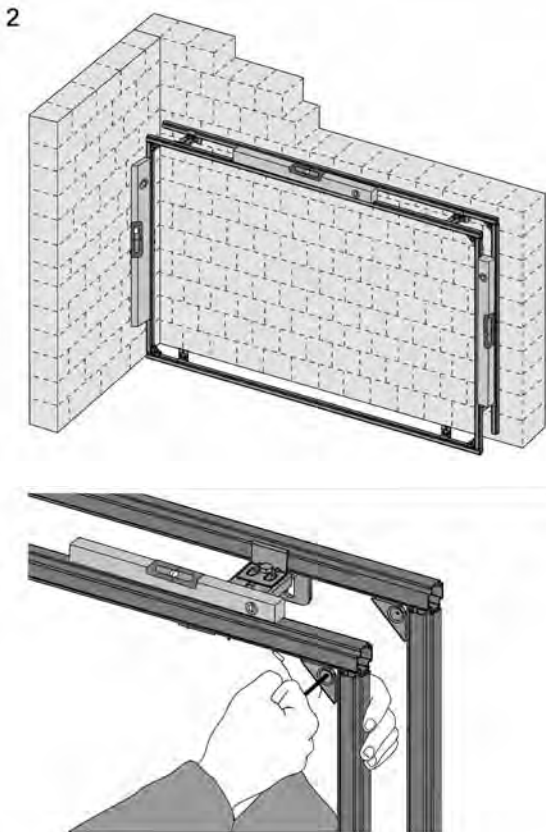

Use a spirit level to align the profiled tube and connect using corner joints

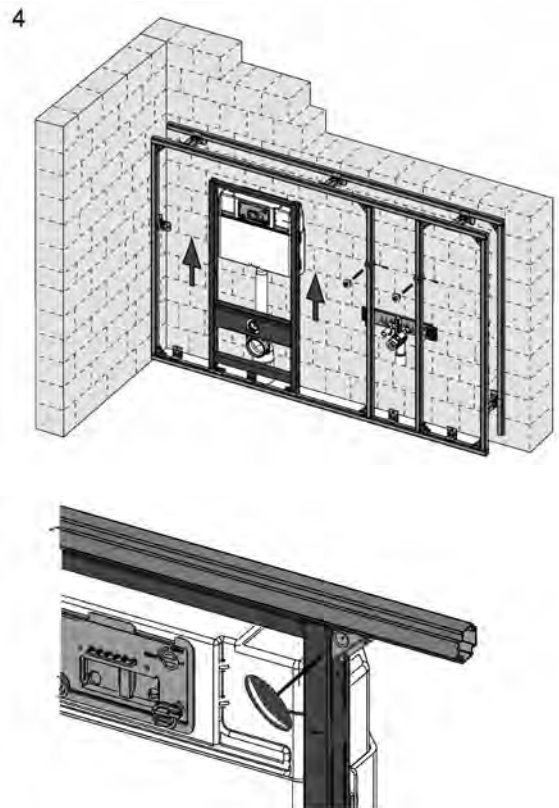

Pull out the module, secure it with corner joints on the upper profiled tube, apply the foot brake, tighten the screws on the module feet (only by hand!)

5

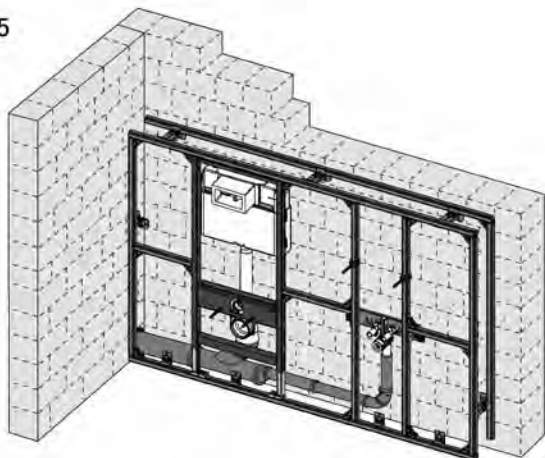

Install the horizontal middle struts

6

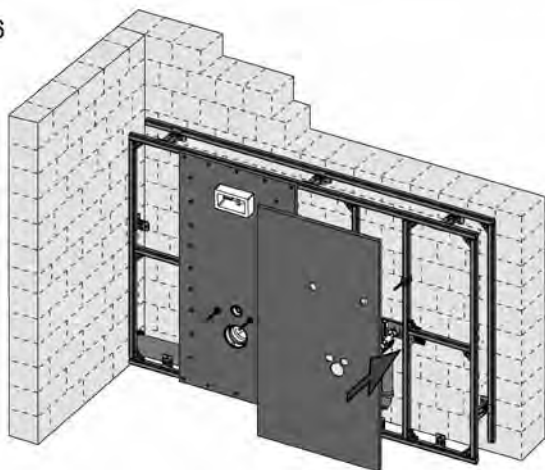

Make the cutouts in the panels, put the panels in place

Covering with plasterboard

The walls are covered with 18 mm thick single-layer plasterboard. As an alternative, 2 x 12.5 mm plasterboard or an equivalent covering can be used. By equivalent is meant for example a combination of plywood panels and plasterboard or covering with gypsum boards. The covering must both be screwed to the vertical module struts and the adjacent vertical supporting frame. We recommend starting panelling the supporting frame at the WC module because the largest number of cutouts is required there.

7

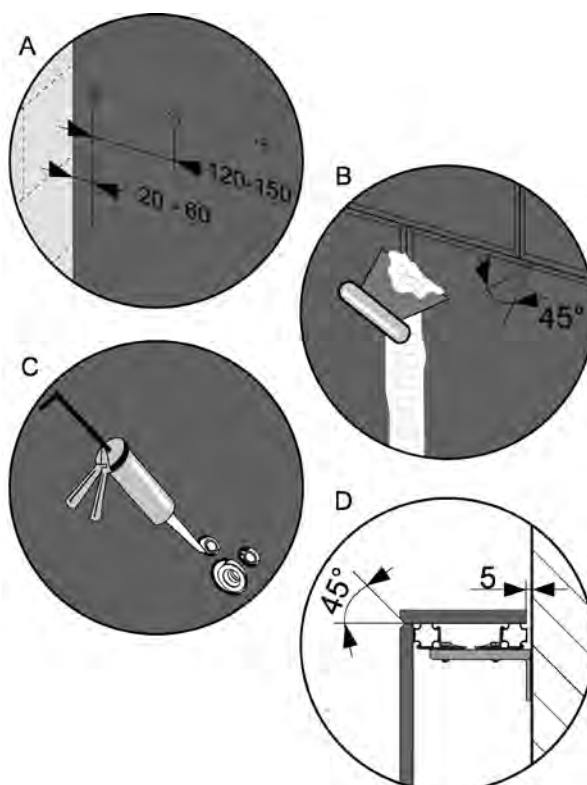
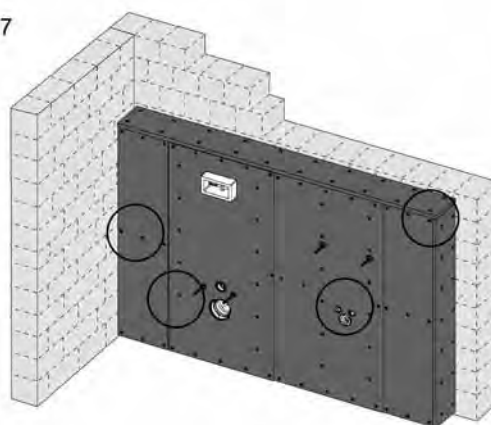

Covering the TECEprofil supporting frame and filling

Practical tip:

The cutouts can be easily marked out using the supplied marking plugs. To do this, press the panelling against the marking plugs. The centre point of the cutout is now exactly marked.

TECEprofil – system installation instructions

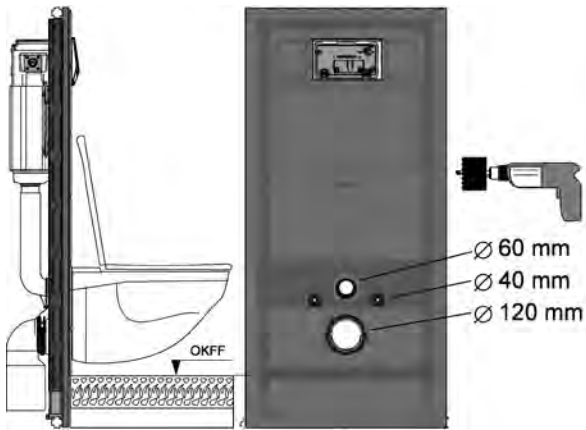

Size of the cutout for the WC module

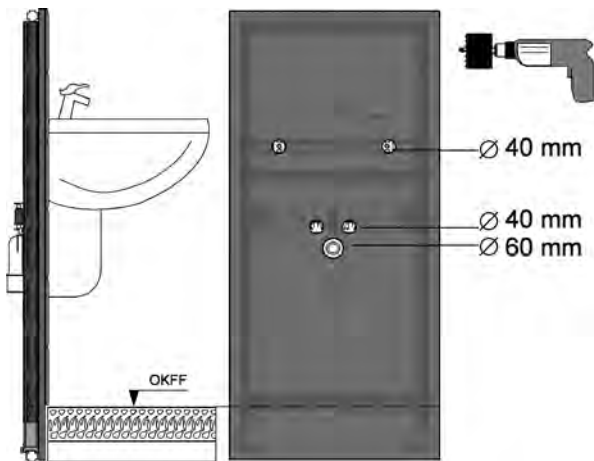

Size of the cutout for the basin module

Note:

The marking plugs are not suitable for a pressure test!

When applying the panelling, the general guidelines for dry-wall construction must be followed. The joints in the covering must be filled with TECEprofil knifing filler.

On non-ceramic surfaces, additional fibreglass

joint ceiling strips must be used. The 5 mm gap between the structural shell and the covering must be filled and sealed with a permanently flexible compound. Cross joints (panels butted vertically and horizontally) must be avoided, the joints should be offset by 30 cm.

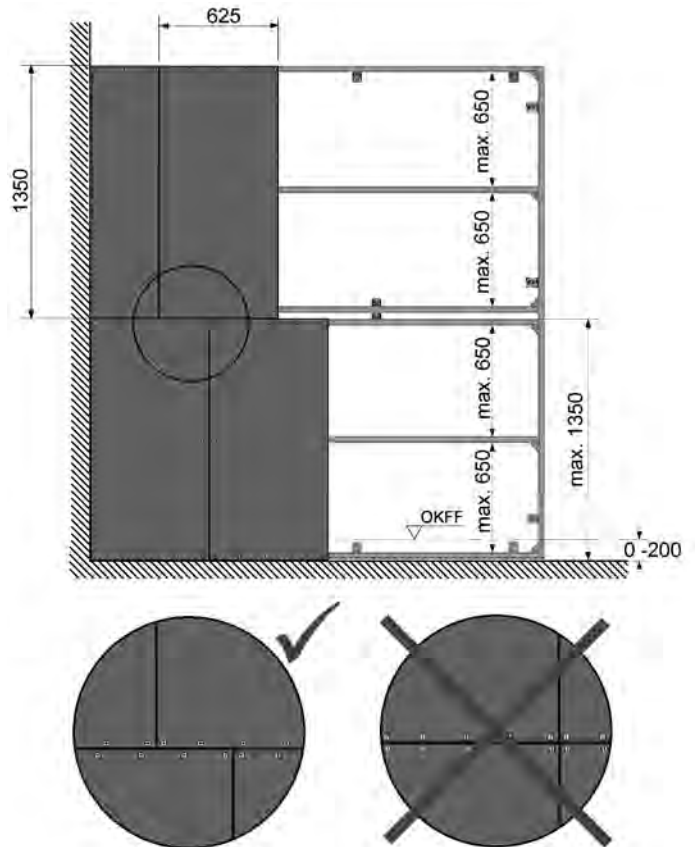

Joint patterns on the panelling

Important: All abutting edges on the plasterboard must be chamfered to 45° !

Filling of plasterboard panels

When plasterboard panels are filled, a distinction must be made between four different levels of quality. If invitations to bid do not specify otherwise, then quality level 1 generally applies.

Quality level 1 covers the following requirements for the filling:

- filling of butted joints of plasterboard panels and
- the coating of the visible parts of the fastening material

projecting material must be removed. Marks, grooves and ridges caused by tools are permitted.

Further information about the surface quality of filler can be read in gypsum industry data sheet no. 2.

TECEprofil knifing filler

TECEprofil knifing filler is a white powder to mix with water and is based on gypsum and PVA with a methylcellulose percentage and cellulose reinforcing fibres. It offers the advantages of a quick plaster, has a very high adhesion and does not sink. TECEprofil knifing filler can be applied as thickly as required in one operation and in the process it hardens without cracks and free of strain.

Application (indoor areas)

- Filling, plastering and smoothing rough masonry, plaster, concrete, filigree ceilings, aerated concrete and foamed concrete, sand-lime blocks, plasterboard, fibre reinforced panels, light construction panels, softboard and insulation panels.
- Filling the joints in plasterboard and gypsum fibreboard without fabric reinforcement. Follow DIN 18181 + DIN 18183 and the working guidelines of the board manufacturer. The site must be dry. With surfaces which are especially stressed, e.g. in the region of installation openings, insert reinforcing strips where appropriate.
- as adhesive binder for securing plasterboard or gypsum fibreboard, expanded polystyrene and fibreboard panels to masonry in indoor areas. Absorbent substrates such as aerated concrete and sand-lime blocks must be primed first with penetrating primer/sealer.
- as gypsum adhesive for non-load bearing gypsum partition wall panels.

Substrate

The substrate must be clean, solid and offering maximum grip. Dirt, dust, wallpaper, as well as old paint and plaster which are not reliably adhering, must be removed. Pre-treat

smooth concrete surfaces with thinned base for plaster, other smooth substrates such as gloss or emulsion paint must be pre-treated with a pigmented primer.

Mixing

Pour clean water into a container and sprinkle in the powder (1 part by volume water to about 2.25 parts by volume powder). Stir vigorously until a very fine, smooth, paste-like compound is formed. To achieve the optimum working properties, wait for about 1-2 minutes and then stir vigorously again.

Working instructions

Apply TECEprofil knifing filler evenly onto the substrate using a smoothing trowel.

- can be worked for about 30 minutes without problem,
- only use at temperatures above 8 °C.

Post-treatment

Post-treatment is not generally necessary. However, if emulsion or gloss paint will be applied, application of penetrating primer/sealer beforehand is recommended.

Panelling for very wet areas

The TECEprofil panel for very wet areas is a 12.5 mm thick, cement-bound light concrete panel with a sandwich structure, reinforced on both sides with a covering of alkali-resistant glass fibre webbing.

In areas in which there is a very high degree of moisture stress to the walls – such as in public shower facilities, swimming pools, fitness areas etc. – special panelling must be used.

For these areas, it is recommended that especially durable and resistant water-repellent panelling material is used.

The 12.5 mm thick, cement-bound TECE panel for very moisture-stressed areas meets these requirements fully.

Design of dry-wall constructions in these areas is only partly covered by standards and directives:

- For use in areas not supervised by the Building Authority, the fundamental standard is the new information sheet "Bathrooms and wet rooms in wooden and dry-wall constructions" issued by the major associations and institutions for dry-wall construction.
- For the Building Authority supervised areas, the information sheet from the Central Association of the German Building Industry (ZDB) applies.

Handling standards

Panel storage and transport:

The panels are packed lying flat and delivered on pallets. Storage should always be lying flat on a smooth base. Storage on edge can lead to distortion of the panels and damage to the edges. If panels are to be put down on ceilings, then the load bearing capacity of the ceiling must be respected without exception. Storage in the open air is possible because of the resistance to frost and water. However, because of the later surface handling, the panels should be provided with a water-repellent covering and contamination through site operations prevented.

Construction site conditions:

As with all materials used in construction, glassfibre light concrete panels are subject to expansion and contraction due to the influence of temperature and moisture.

The following handling conditions must be adhered to in order to perform dry-wall work correctly.

- Only install glass-fibre light concrete panels when the air humidity is less than 80 %
- Soaked panels must never be handled until they have completely dried out. Damaged material must not be installed.

- Due to the technical process, bonding of glass-fibre light concrete panels must be done with air relative humidity < 80 % and room and material temperatures of at least + 5 °C
- In the process the temperature of the adhesive must be > 10 °C. The panels must have acclimatised to the conditions in the room because they must not change appreciably in the 12 hours following bonding.
- Low temperatures and high relative humidity prolong the hardening times. Heating using a gas torch can cause damage because of the danger of condensation being formed. This especially applies for indoor areas with poor ventilation. Sudden rapid heating must be avoided.

Cutting out:

Cement-bound lightweight concrete panels can be cut using a standard rail-guided portable circular saw with extraction, preferably as a plunge saw. To cut panels as exactly to size as possible and with sharp edges, a saw blade with a smaller number of teeth is recommended. Cutouts and curves can be cut conveniently using a jigsaw.

Panelling:

The TECEprofil walls can be panelled using the extremely robust glass-fibre light concrete panels in single layer construction. They should be installed with the noticeably smoother face to the front. Direct tiling is possible, depending on the application in question. With multi-layer panelling, only the joints of the outer layer of panels need to be bonded together. Cross joints are not permitted ! The offset of the joints between the panels must be at least 200 mm. For the purposes of good bonding, the panels must be cut absolutely straight and with sharp edges.

Fixing:

The glass-fibre light concrete panels are secured to the TECE supporting frame using the same type of screws and with the same screw separation as for the plasterboard panels. Pre-drilling is not required.

Joint technique:

Differently to plasterboard, glass-fibre light concrete panels are bonded to each other bluntly. Only the Fermacell joint adhesive (Order No. 9 200 014) is permitted for this. About 20 ml of adhesive is required per meter. A 310 ml cartridge will therefore bond about 15.5 m of panel joints. The bead of adhesive is applied to the edge of the panel. It is important that the adhesive completely fills the joint when the two panels are pressed together (adhesive visible on the joint). The maximum width of the joint must not exceed 1 mm. To prevent disturbance to the film of adhesive during subsequent fixing and hardening, the joint should not be pressed together "to nothing". Depending on room temperature and humidity, the adhesive is set after about 12–36 hours. Afterwards the excess adhesive is completely removed. This can be done using a putty knife or a scraper.

Job steps for moisture stress class A (high wetness stress)

In moisture stress class A areas, the whole surface of the panelling must be sealed with a sealing system (including the flexible adhesive).

For sealing systems for the remaining moisture stress classes, please refer directly to the manufacturers of chemicals for building applications.

Job steps required:

1. Bonding the abutting edges
2. Removal of protruding joint adhesive after it has set
3. Filling of visible fastening material using fine filler or skim coating.
4. Application of a sealing system (penetrating primer/sealer, liquid membrane, sealing tape, possibly a wall sealing collar) (see illustrations 1 and 2)
5. To seal pipe penetrations, the sealing collar is bedded into the still-wet liquid membrane and immediately brushed over with it again (see illustration 3)
6. Application of the flexible adhesive



Fig. 1 Application of the lower sealing coating



Fig. 2 Bed the sealing collar into the still-wet sealing coating

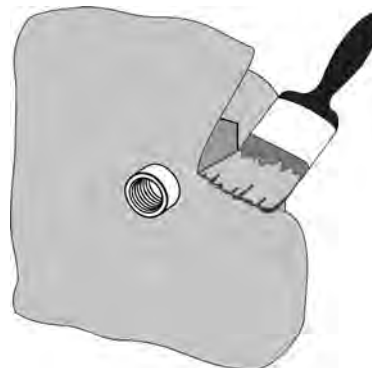
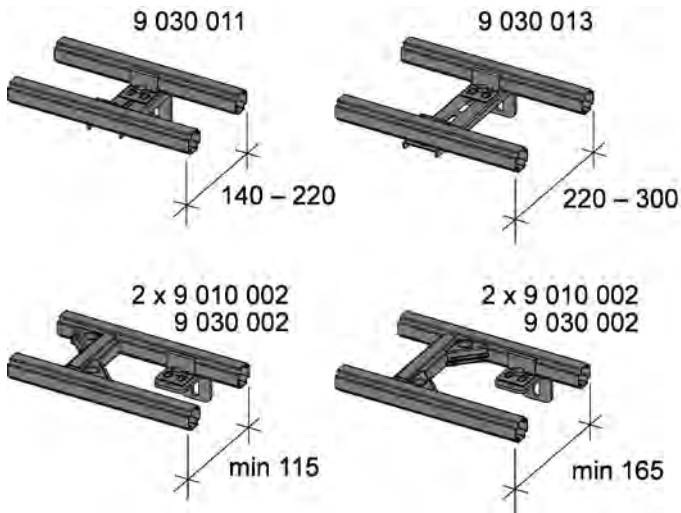

Fig. 3 Application of the upper sealing coating

TECEprofil – system installation instructions

Possible pre-wall heights and depths



Possible pre-wall depths with TECEprofil supporting frame

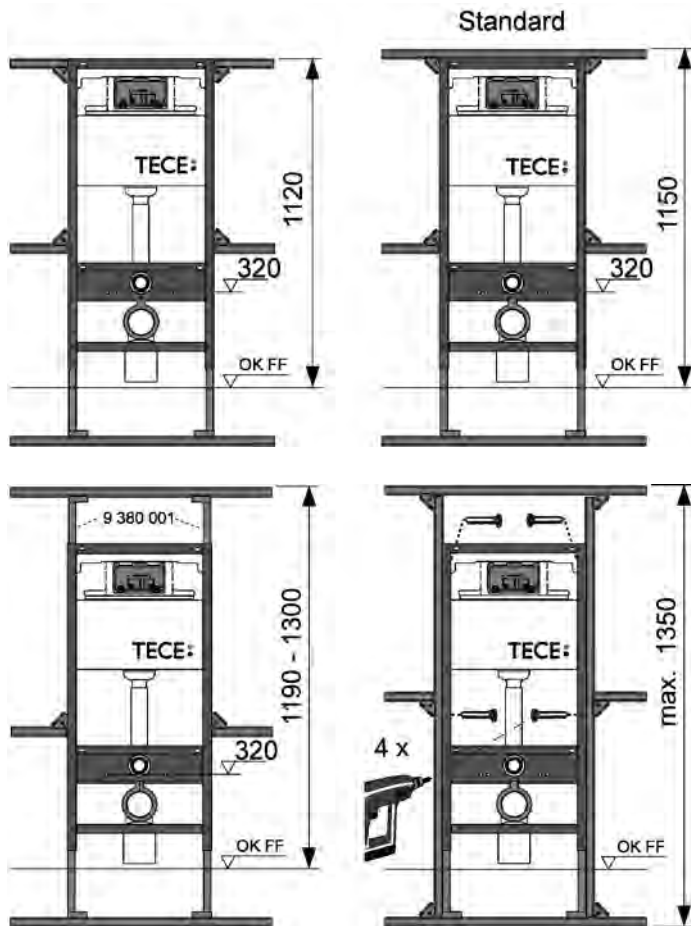





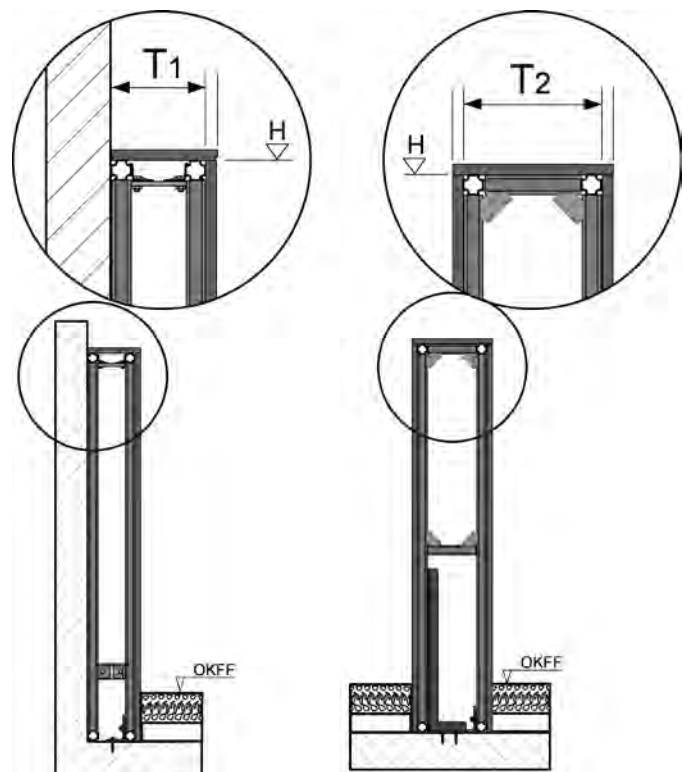

Possible pre-wall heights with TECEprofil supporting frame - 1

	Order No.	H Standard	T1 min.	T2 min.
 DN 100	9 300 000	1150 (1120-1350)	160	210
	9 300 003			
	9 300 007			
	9 300 011			
	9 300 033			
	9 300 044			
 DN 50	9 300 022	980-1080	160	210
	9 300 001	820-920	160	210
	9 041 006	970-1350	160	210
	9 310 000	1150 (1120-1350)	140	210
	9 310 004		(115)	
	9 020 033	820-1350	140	210
9 020 018	(115)			
9 020 034				
 DN 50	9 320 002	1150 (1120-1350)	140 (115)	170
	9 320 000			
	9 320 001			
	9 020 017			
 DN 50	9 330 000	1150 (1120-1350)	140 (115)	210

Possible pre-wall heights with TECEprofil supporting frame - 2



Limits

Description	Type	Height	Depth	Width	Symbol
Standard wall	Standard wall, partial height and room height, with or without side fixing	Standard 1150 mm, max. 3870 mm	-	-	
Free-standing wall	Partial height, without side fixing	Standard 1150 mm, max. 1500 mm	min. 210 mm	max. 2400 mm	
	Partial height, fixing one side	Standard 1150 mm, max. 3870 mm	min. 210 mm	max. 2400 mm	
	Privacy screen, partial height, fixing one side (only permitted for fittings installation)	max. 2000 mm	min. 170 mm	max. 1200 mm	
	Room height, fixing one side	max. 3870 mm	min. 210 mm	max. 2400 mm	
	Dividing wall, room height, fixing one side	max. 3870 mm	min. 170 mm	Vertical strut required every 2400 mm on each wall side!	
Special wall	Corner construction 45°, partial or room height in a structural shell corner	max. 3870 mm	min. 350 mm	min. arm length 495 mm	

The heights given refer to the height between the top of finished floor and the top of the supporting frame. All dimensions refer to the supporting frame without panelling. The standard shelf height of 1150 mm (supporting frame height above top edge of finished floor) can easily be changed.

Protection against moisture

TECEprofil can be used in damp rooms (bathrooms, guest toilets, cellars). Use in wet rooms (swimming pools) is not possible. The implementation of "Sealing against non-pressing water" is described in DIN 18195/T5 "Water-proofing of buildings".

Penetrations at basins, urinals, bidets etc. must be sealed with permanently elastic material. All unfilled cut edges of panelling must be treated with penetrating primer/sealer before tiling. The edge between the floor and the TECEprofil panelling must be sealed with a standard sealing tape. Additional seals against moisture, such as in the area of the shower must be created by the tile layer. The tile laying trade organisation has created a special information sheet for this.

(ZDB information sheet: Instructions for processing sealants together with coverings and claddings made of tiles and flags for indoor and outdoor areas)

Floor fixing

The TECEprofil pre-wall can be mounted both on the unfinished floor and the finished floor. Here the plugs supplied must be anchored in the floor over their complete length. The compression strength of the floor must be at least 5 N/mm². Free-standing walls must be anchored into the unfinished floor. If the installation is on a wooden floor, secure fixings into the joists must be ensured.

Equipotential bonding

The TECEprofil system manages without equipotential bonding. Electrical equipment must be installed in accordance with the VDE regulations. Sanitary items made of metal, such as shower trays or stainless steel basins as well as all metal pipework must be connected with equipotential bonding.

For more information on this, please refer to: VDE 0100.

Cantilever loads

When items are attached to a TECEprofil light construction wall, cantilever loads are introduced into the wall. A distinction is made here between light, medium and heavy cantilever loads. Heavy cantilever loads are generally absorbed by a module or by a special connection unit. Medium cantilever loads must be connected to the supporting frame. Light cantilever loads can be directly secured to the panelling at any desired position. Suitable wall plugs must be used for fixing. Usually the fastening materials supplied with hand towel holders or mirror cabinets are also suitable for fixing to plasterboard. Plug manufacturers offer a large selection of suitable fixing plugs made of plastic or metal.

Light cantilever loads

The permitted console load is given as load per meter of wall. The values given depend on the overhang of the load. Loads up to 40 kg/m of wall length with an overhang of 30 cm can be placed at any point on the supporting frame, directly onto the panelling. For other values, please refer to the following diagram.

Medium cantilever loads

Medium cantilever loads up to 70 kg/m of wall length with an overhang of 30 cm may be secured to the struts of the supporting frame. The fixing is made using an M 8 or M 10 anchoring clip (Order No. 9 040 004 / 9 040 001).

Heavy cantilever loads

Cantilever loads in excess of 70 kg/m of wall length require a special fixing with modules or connection units, e.g. with a WC module or a mounting plate for handrail and support systems.

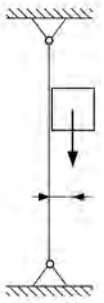
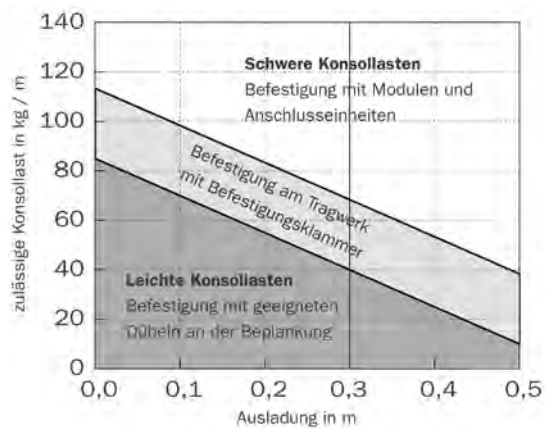

Cantilever loads

The following maximum loads can be assumed for the usual items of equipment (reference values):

- Pictures and mirrors approx. 15 kg
- Bathroom and mirror cabinets approx. 40 kg
- Toilet paper roll approx. 2.5 kg
- Hand towel holder approx. 8 kg
- Grab rail approx. 80 kg
- Rail for bath towel approx. 25 kg

Depending on the overhang, these items can normally be screwed directly to the panelling using the supplied fastening material.

TECEprofil Universal module

The TECEprofil universal module is an all-rounder. Only one module is needed for all current dry-wall constructions. This saves storage space and makes calculation and logistics easier.

Example

The TECEprofil universal module with TECE concealed cistern:



WC universal module, assembly height 1120 mm

- Clearly visible: stamped meter mark.
- Sturdy, self-supporting mounting frame All WC modules are structurally self-supporting and can withstand a maximum load of 400 kg. Holes in the crossbeam allow upgrade for washlet connections.
- Pre-drilled holes for fixing to UA-profile and wooden post-and-beam structure .
- Sturdy crossbeam with riveted-in threads for standard ceramics with a distance between fixings of 180 mm. There are additional holes provided for ceramics with a distance between fixings of 230 mm. The crossbeam permits the ceramics to be held securely even with high loads.
- Integral foot brake makes it easy to adjust the height of the module.
- Adjustable support feet for a floor buildup from 0 to 200 mm. For securing to the floor or to a TECEprofil rail.
- Two-part WC drain bend DN 90/100 This allows DN 90 and DN 100 drain pipes to be connected easily. Furthermore, the DN 90/100 adapter can also be

individually installed in the module as a horizontal discharge. Consequently, it is easy to directly connect downpipes behind the module.

- Many upgrade options, such as wooden panels to accept handrails, washlet solutions, corner installations and many more.

The use of universal module technology also means an extended range of applications:

- in a TECEprofil pre-wall
- in front of a solid wall
- in a C-profile wall
- in a UA-profile wall
- in a wooden post-and-beam wall

Installation in a TECEprofil pre-wall



Installation in a TECEprofil pre-wall

The simple installation technique permits speedy and safe working. The universal modules can be quickly and safely installed in a TECEprofil wall with only a few hand movements:

- Release the foot brakes
- Place the module feet on the lower continuous profile brace
- Pull out the module; the foot brake is on hard enough to carry the weight of the module and to prevent it from sliding back
- Secure the module with the corner joints to the upper profile brace
- Reapply the foot brakes
- Tighten the module feet – only by hand!
- Installation of the middle profile braces

TECEprofil – universal module

As well as installation in a pre-wall, the module can also be inserted in a free-standing wall made up of TECEprofil system components:

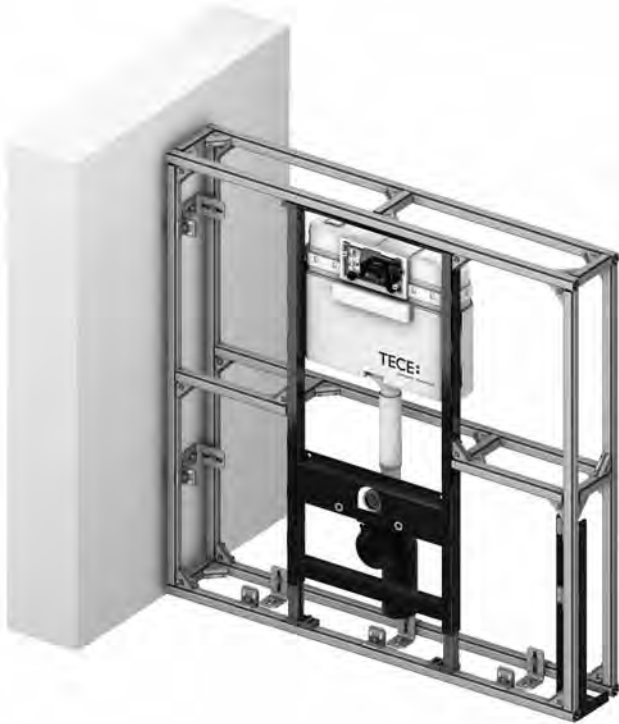

Installation in a free-standing TECEprofil wall

Installation in front of a solid wall

The TECEprofil universal modules are also suitable for individual installation. Appropriate fastenings are offered for the different installation situations. The universal modules are structurally designed in such a way that in the standard situation, they only need to be secured at four points to a structural shell able to take the load. Additional fixings such as WC pan angle brackets are only necessary where high loads are involved (e.g. barrier-free toilet facilities). The fastening material provided with the units is suitable for installation on solid walls. When securing to lightweight partition walls, wall plugs suitable for hollow walls must be used. In addition, reinforcement of the light partition wall must be provided at the securing points. The procedure must be agreed with the dry-wall builder. The installation instructions of the dry-wall system being used must be respected.

Individual module installation with depth-adjustable universal fixing (Order No. 9 380 000):



Individual module installation with depth-adjustable universal fixing

The universal module is placed directly against the wall. The universal fixings can be used to set the depth of the pre-wall. The module height is adjusted using the pull-out module feet. The foot brake prevents the module from sinking. In this way, the module can be exactly positioned before the module feet and the universal fixings are secured to the structural shell.

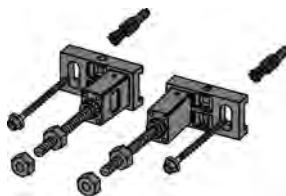

Universal fixing 9 380 000

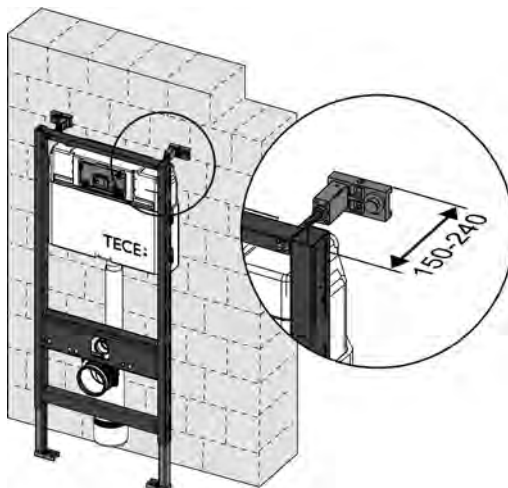

Adjustment range of the universal fixing 150 – 240 mm

Individual module installation with height-adjustable module attachment (Order No. 9 380 002):



Individual module installation with height-adjustable module attachment

With the height and depth adjustable module attachment, variable supporting frame heights from 1160 mm to 1300 mm can be achieved. This allows the height of the module to be adapted, for example to the height of an existing tile pattern.

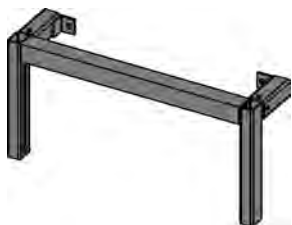

Universal fixing 9 380 002

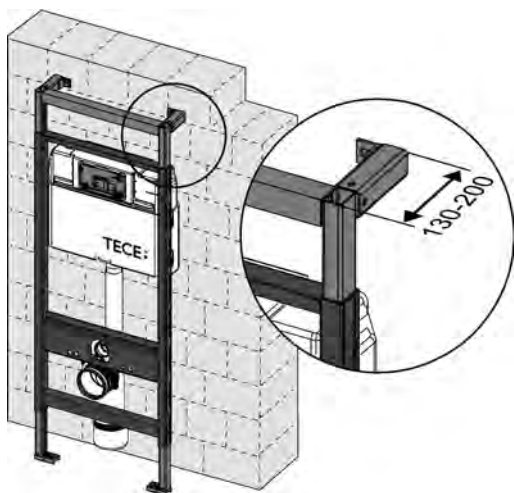

Adjustment range of the height-adjustable module attachment 130 – 200 mm

Installation with module attachment for corner of wall mounting (Order No. 9 380 004)



Installation with module attachment for corner of wall mounting

Using the module attachment for corner of wall mounting, the TECEprofil universal module can be secured at an angle of 45° to the wall of the structural shell. The attachment here is screwed to the structural shell at only one of the arms. There are two angle plates provided for installation of the panelling. The short arm length of the attachment permits layouts with a footprint of only 0.14 m².

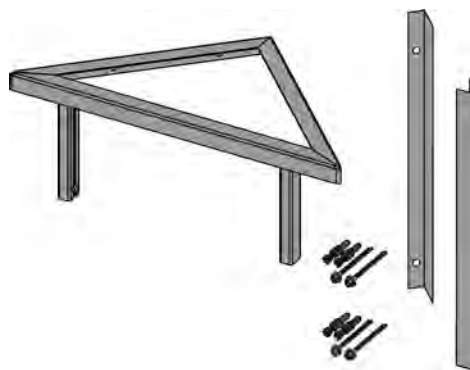

Module attachment for wall corner mounting 9 380 004

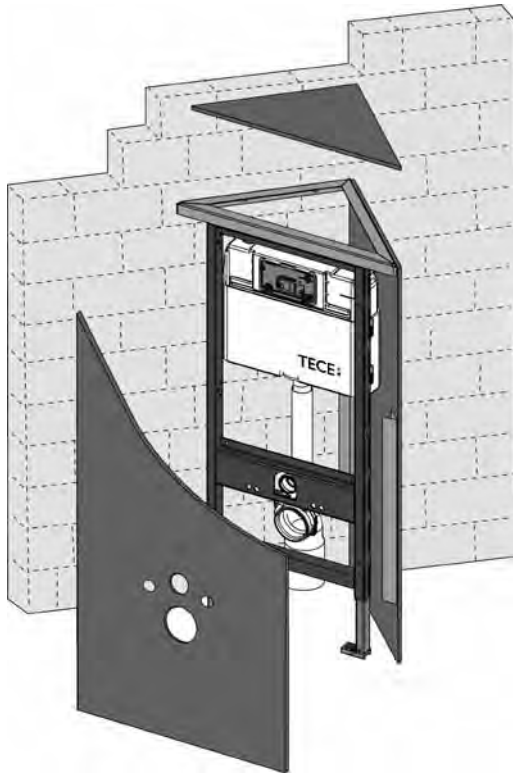

Installation of module attachment for corner of wall mounting

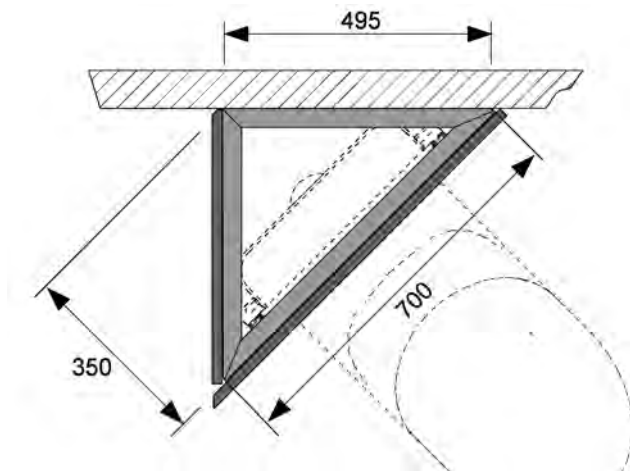

Dimensions of module attachment for corner of wall mounting

Installation of module attachment for variable corner mounting (Order No. 9 380 003)



Module attachment for variable corner mounting 9 380 003



Installation of module attachment for variable corner mounting

The universal module can be secured directly to the structural shell with corner attachments. The corner attachment permits parallel installation of a TECEprofil brace. With two TECEprofil braces, one angle bracket and one corner angle bracket, a storage shelf can be constructed. Installation in a corner takes up very little space. The attachment set has an arm length of only 49.5 cm. The shelf depth from the front edge of the module to the corner is only 35 cm. Despite the minimal installation depth, it is possible to fit a DN 100 drain pipe behind a WC module.

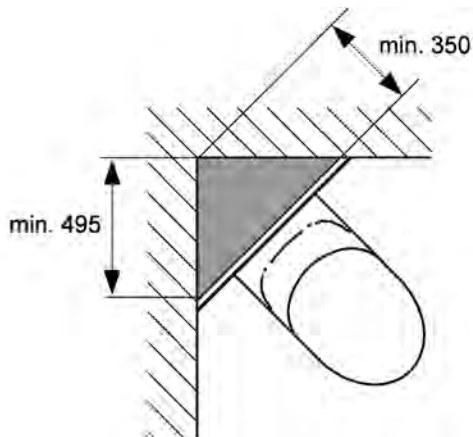

Dimensions of module attachment for variable corner mounting

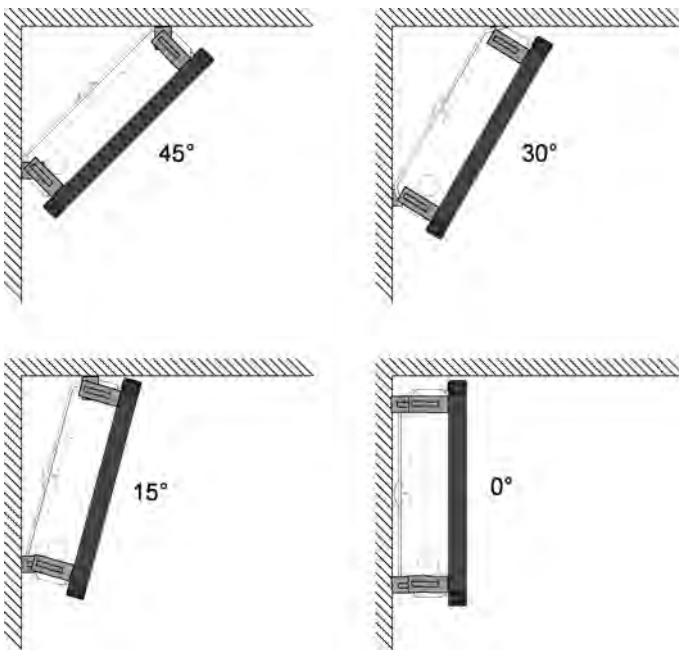

Example installation of module attachment for variable corner mounting

Installation in a room height C-profile steel post-and-beam wall



Installation in a room height C-profile steel post-and-beam wall

In double post-and-beam walls, the individual stud rows must be firmly connected to each other according to DIN 18183. To achieve this, 30 cm anchors are screwed in between the C-profiles. Two reinforcing anchors are installed directly above the universal module. The module is screwed to the wall sections at each of four points using the self-tapping screws provided. The module feet are in the front horizontal C-profile and are screwed to the floor using plugs.

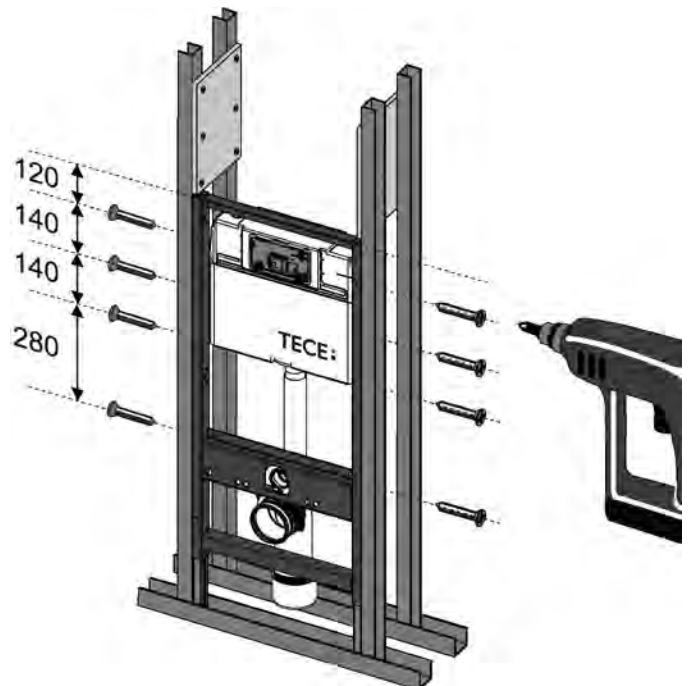

Securing the module during installation in a room height C-profile steel post-and-beam wall.

The installation instructions of the dry-wall system being used must be adhered to.

Installation in room height steel post-and-beam wall with UA-profiles



Installation in a room height UA-profile steel post-and-beam wall

If particularly wide or high walls have greater rigidity, UA-profiles according to DIN 18182 part 1 can be used instead of C-profiles. This measure is useful with universal modules for WC and bidet.

For a disabled toilet system, the front and rear braces should be exclusively UA-profiles, for reasons of rigidity. A disabled and senior citizen toilet system in the public sector is constructed in accordance with DIN 18024-2.

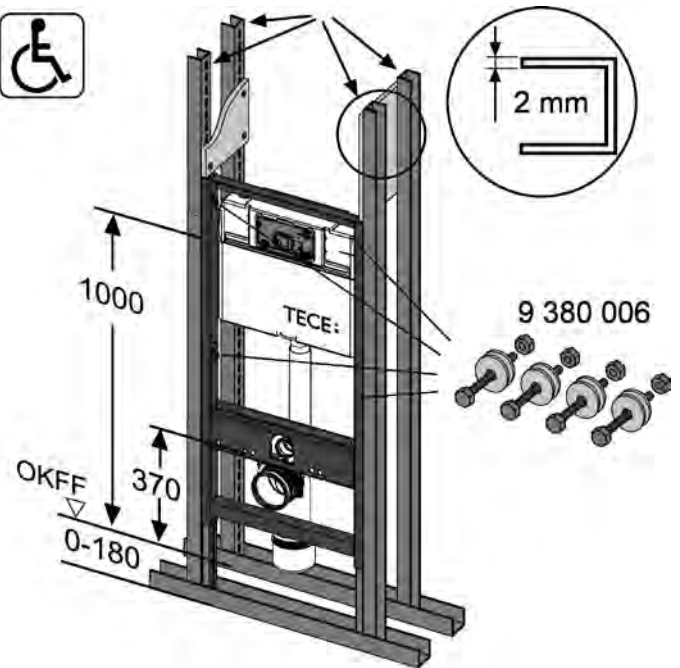

Securing the module during installation in a room height UA-profile steel post-and-beam wall

Because of the specified seat height of 48 cm, the universal module must be installed 5 cm higher compared with the usual construction. The TECEprofil universal modules have pre-drilled holes in the side braces, for securing the universal modules to the UA profiles. The holes are arranged so that there are always at least two securing possibilities per brace.

Installation in a wooden post-and-beam wall



Securing individual modules to the floor

The feet of the universal modules are secured on the unfinished floor using the screws and plugs supplied. Here the complete length of the plugs must be anchored in the floor. The compression strength of the floor must be at least 5 N/mm². If the installation is on a wooden floor, secure fixings into the joists must be ensured.

Installation in a wooden post-and-beam wall

As well as steel post-and-beam wall, the module can also be installed in wooden post-and-beam wall according to DIN 4103-1. To do this, the frame is secured to the vertical braces using special wood screws (Order No. 9 380 005).

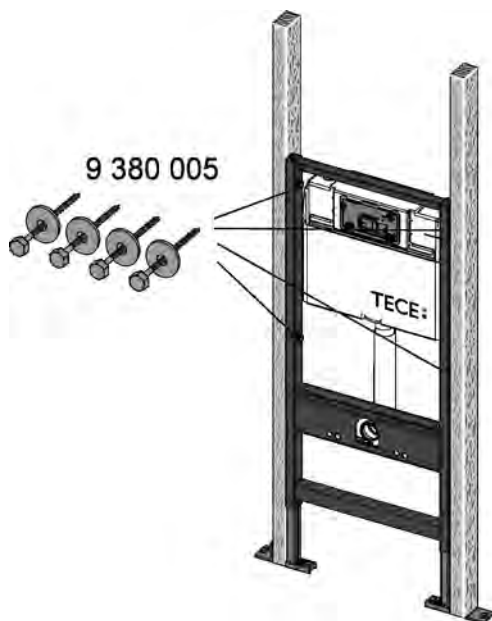

Securing the module during installation in a wooden post-and-beam wall

The pre-drilled holes are also used to secure the universal module to the wooden braces. The holes are arranged so that there are always at least two securing possibilities per brace.

Toilet module with connection for odour extraction

For applications including odour extraction, TECE offers a WC module with a DN 70 outlet on the flush pipe. The DN 70 connection offers the advantage that no further nominal width changes usually need to be made. The DN 70 fitting is universal and therefore allows any commercially available fan (e.g. Maico ER 60 or ER 100 with Maico ER-UP fan housing and ER-AS extraction sleeve) to be connected. Odours are extracted directly via the WC ceramics through the flush pipe. Intensive testing confirms that the flush performance is not adversely affected by the side connection for the odour extraction. To prevent any draught effect, the extraction flow volume should not exceed 18 m³/h.

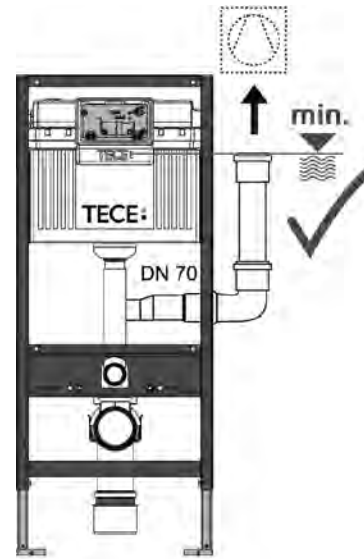

Watertight installation to the cistern head of water



Note:

Because some of the flushing water also reaches the vent pipe (principle of communicating pipes), the connected vent pipe must always be installed watertight to above the head of water of the cistern. Direct connection to a corrugated pipe at the flush pipe connection is not suitable for this.

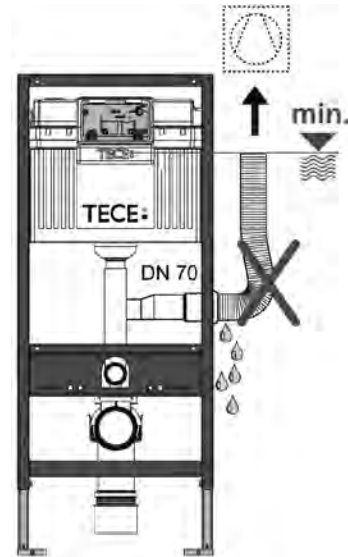

Corrugated pipe must not be connected

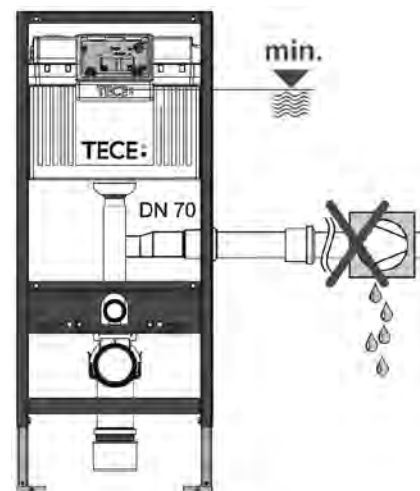

Fan must not be connected below the head of water of the cistern.

Multi-family house:

In toilet areas without an outside wall in multi-family houses, the toilet element can be easily connected to the room fan. This is achieved using the existing DN-70 connection sleeve, which permits connection to the concealed housing with a second room connection via plastic pipes. The large cross-section of 70 mm ensures a low air speed and permits effective, draught-free odour extraction. The moisture in the extracted air condenses on the inner wall of the air extraction pipe before it reaches the fan.

Single-family house:

The WC element with odour extraction can also be used in a single-family house. If the bathroom has an outside wall, the extraction pipe of the WC element is connected to an in-duct fan. Odour extraction can therefore be easily implemented, without adverse effects such as a temperature drop caused by opening the window, which in turn leads to higher heating costs.

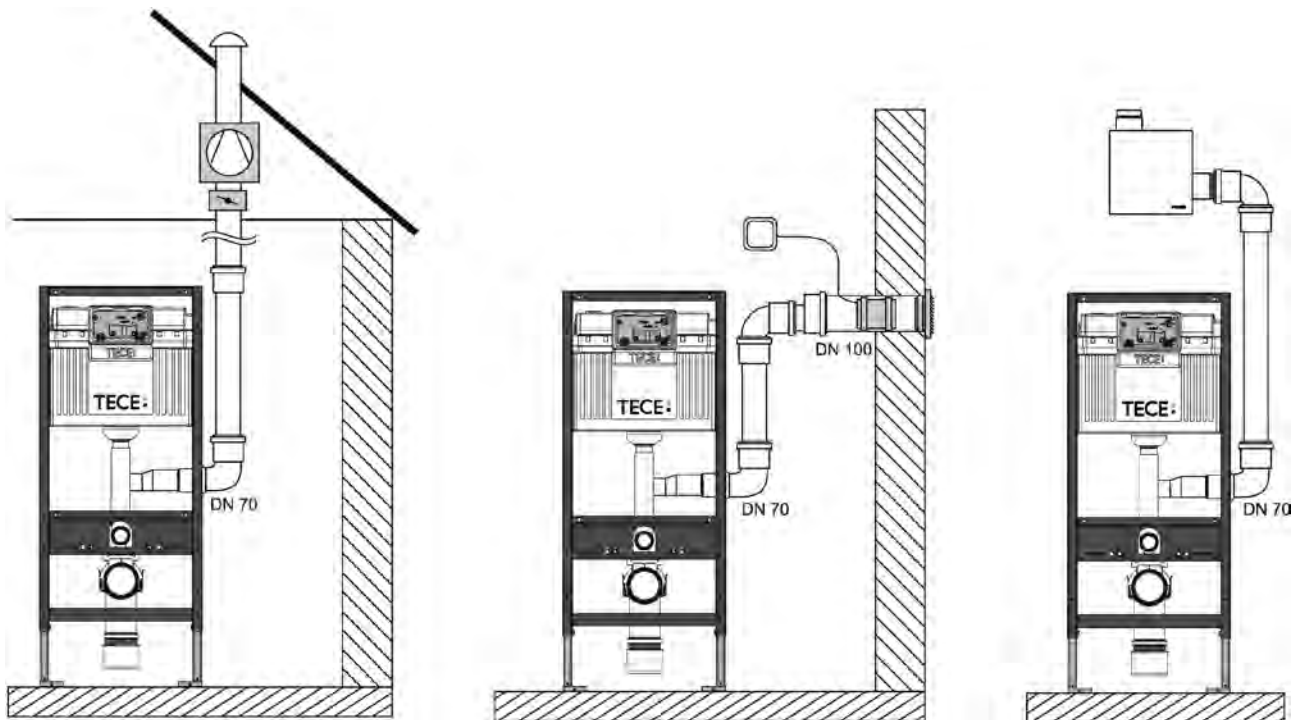
Installation examples:

Individual or module construction

The supporting frame is built using the four basic components – profiled tube, corner joints, double brackets and angle brackets. When installing sanitary items, the plumber has the choice between individually installed connection units and the TECEprofil universal modules.

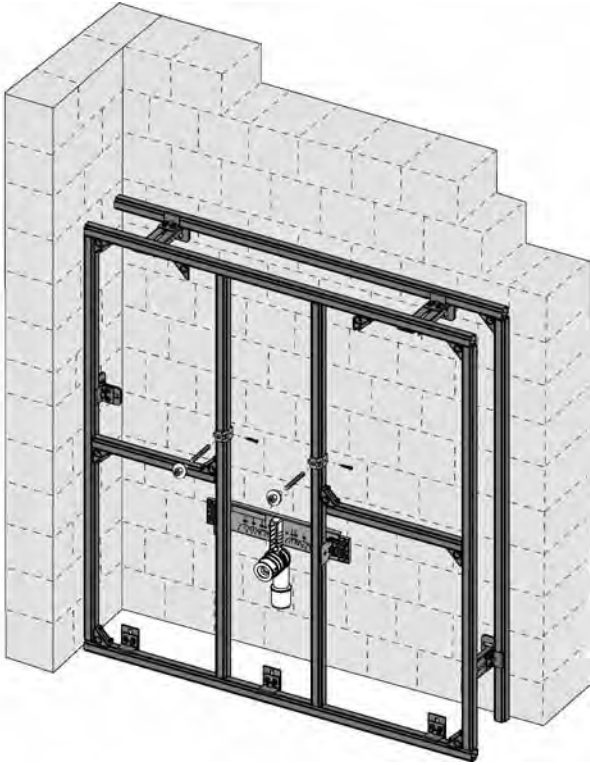

Individual construction with connection unit for basin

Alternatively, the same installation can be performed with a TECEprofil universal module. The TECEprofil universal modules can not only be built into a TECEprofil supporting frame, in addition they can also be installed in metal or wooden post-and-beam walls

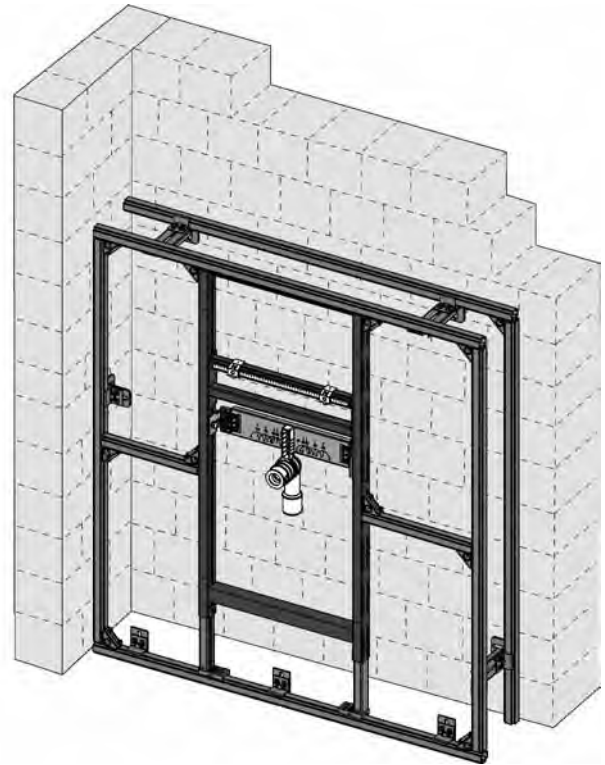

Modular construction with universal module for basin

TECEprofil bath construction

A framework base is created using TECEprofil. Plug-in feet (Order No. 9 140 000) are inserted into the four side braces. With an adjustment range of 30 mm, these allow height adjustment and alignment. Steel bathtubs can be installed without the need for additional supporting feet under the bathtub.

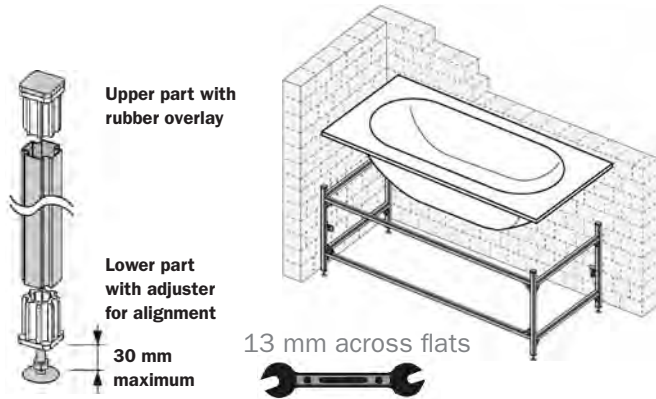

Installation of a steel bathtub in a TECEprofil supporting frame

TECEprofil profile braces

When cutting the horizontal profile braces, the thickness of the vertical profile braces, the panelling and the thickness of the tiles must be taken into account.

You can calculate the exact profile length using this formula:

- Bathtub length/width**
- 2 x thickness of vertical profile brace
- + panelling
- + tile thickness
- = length of horizontal profile brace

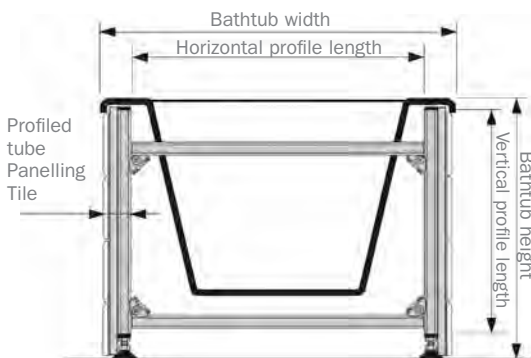

Exact calculation of the bathtub length/width for free-standing bathtubs

For the horizontal braces, the following rule of thumb formula applies in most cases:

- Bathtub length/width**
- 12 cm
- = length of horizontal profile brace

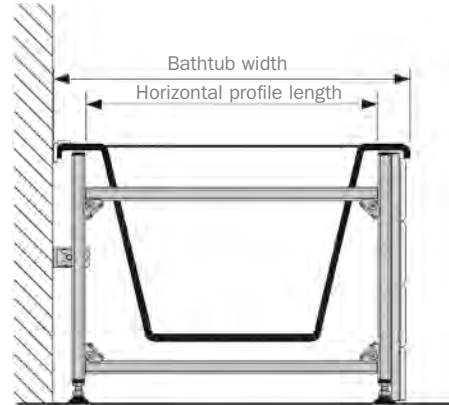

Calculation of the estimated bathtub length/width for built-on bathtubs

When installation is onto the unfinished floor, the floor buildup must be taken into account when finding the length of the vertical braces. The length of the profiles is as a result:

- Bathtub height**
- + floor buildup
- plug-in foot (4.5 cm)
- = length of vertical profile brace

Special features of acrylic bathtubs

To securely erect an acrylic bathtub, the base plate must be supported by an acrylic bathtub foot. This is screwed to the laminated base board. The fastening material required is usually supplied with the bathtub foot.

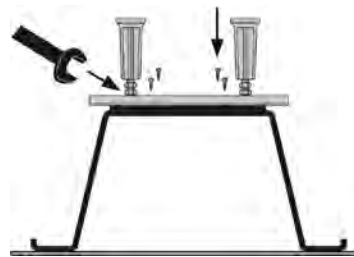

Installation of the acrylic bathtub feet

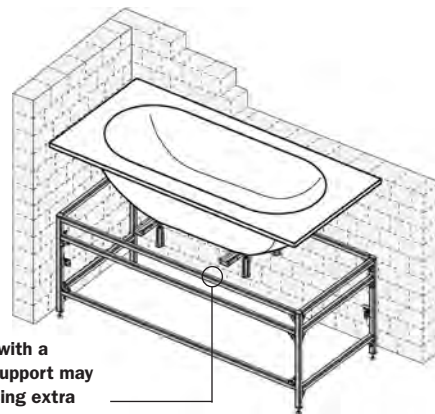

Installation of an acrylic bathtub in a TECEprofil support frame

Particularities when installing the overflow fittings

On some bathtubs the outlet and overflow fittings are very close to the outer edge. Here it may be necessary to interrupt the upper horizontal brace. This can be done at any location using the universal TECEprofil tube and the corner joints.

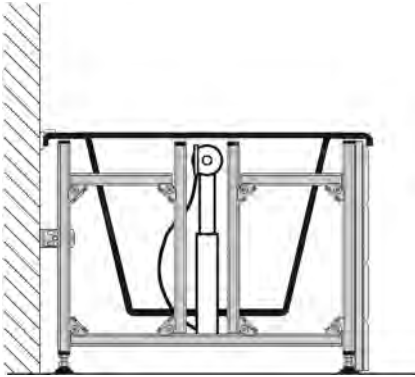

TECEprofil supporting frame when installing an overflow fitting

Securing the bathtub

To secure it in place, the bathtub is clamped at its edge to a wall of the structural shell using bathtub anchors.

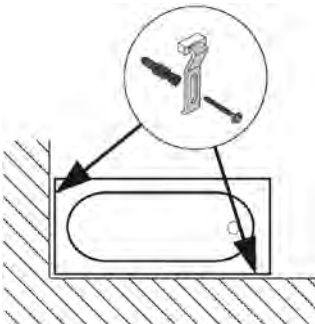



Securing the bathtub using bathtub anchors

Bathtub insulation tape with tear-off edge

In order to prevent an acoustic bridge between the edge of the bathtub and the structural shell, bathtub insulation tape is fixed to the side of the bathtub edge. With the tear-off edge, the upper half of the tape can be cleanly removed during completion work. A silicone bead is then placed between the edge of the tiles and the bathtub.

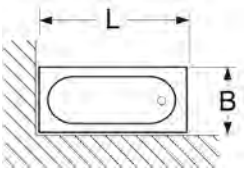
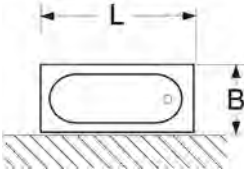
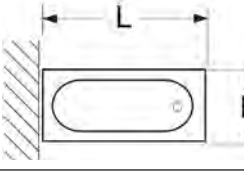

Sealing with bathtub insulation tape and a silicone bead

	Bathtub length L	Bathtub width B	Profiled tube 9 000 000	Corner joints 9 010 002	Angle brackets 9 030 002	Double brackets 9 030 011	Universal fixing 9 018 002	Fitting connection crossbeam 9 020 035	Plug-in foot 9 140 000	Bathtub anchor	Bathtub insulation tape	Panelling area 9 200 000
	m	m	m	Qty	Qty	Qty	Qty	Qty	Qty	Qty	m	m ²
	1.60	0.70	7.4	12	2	-	-	-	4	2	2.3	1.3
	1.70	0.75	7.8	12	2	-	-	-	4	2	2.5	1.4
	1.80	0.80	8.2	12	2	-	-	-	4	2	2.6	1.5
	1.60	0.70	7.4	12	2	-	-	-	4	2	1.6	1.7
	1.70	0.75	7.8	12	2	-	-	-	4	2	1.7	1.9
	1.80	0.80	8.2	12	2	-	-	-	4	2	1.8	2.0
	1.60	0.70	9.2	12	2	-	-	-	4	2	0.7	2.3
	1.70	0.75	9.7	12	2	-	-	-	4	2	0.8	2.4
	1.80	0.80	10.2	12	2	-	-	-	4	2	0.8	2.6
	1.10	0.57	13.8	25	5	2	4	1	6	2	2.2	2.0
	1.10	0.62	14.2	25	5	2	4	1	6	2	2.3	2.0
	1.30	0.64	15.4	25	5	2	4	1	6	2	2.6	2.4

Material requirements for a typical TECEprofil bathtub construction

Washlet solutions

Washlet solutions are becoming increasingly important in Germany. Modern washlets combine WC and bidet technologies. Because of the universal module technology and the upgrade set for modules, TECE offers the facility to install the most modern washlet solutions on the market.

TOTO Neorest washlet

The WC module (Order No. 9 300 044) from TECE is the only WC module on the market which can be installed with the TOTO Neorest washlet without any problems.

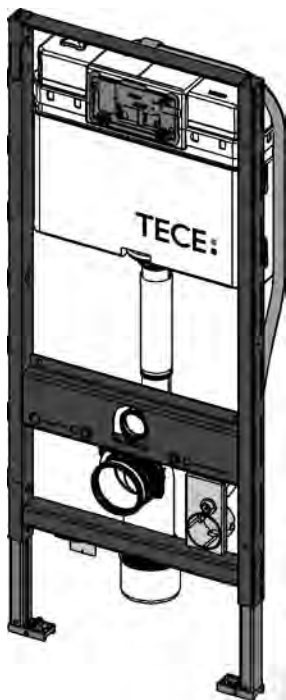

WC module for TOTO Neorest LE/SE washlet

The module is fully prepared: with a wall plate for subsequent water connection, a cavity wall connector socket for power connection as well as an empty pipe together with a control cable. The control cable is needed to trigger the motor unit for the TOTO electronic flush actuation. Everything needed during shell construction is provided by TECE. The material for the completion work (e.g. the motor unit, Neorest washlet etc.) comes from the TOTO company.

Upgrade set for wall-hung washlet

Geberit AquaClean® 4000 / 5000 / 8000 / 8000 plus

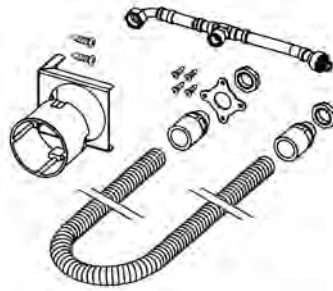

Upgrade set for wall-hung washlets

The upgrade set (Order No. 9 880 034) must be installed on the WC module during the shell construction stage. It has been specially developed for the standard TECEprofil WC module with an overall height of 1120 mm. When this upgrade set is used, it is quite straightforward to install a Geberit AquaClean® washlet series 8000. The crossbeams of the WC module are already prepared for the installation of the empty pipe. For installation of the empty pipe for the water supply pipe, the water connection at the side of the cistern must be moved upwards. The supplied armoured hose with branch replaces the original armoured hose in the TECE tank. All parts are matched to each other and can be installed easily.

Caution!

For patent reasons, the concealed power connection may not be installed in Austria, Belgium, Switzerland, Germany, France, Great Britain, Italy, Liechtenstein and the Netherlands up until 12th September 2021. Please install the power connection beside the washlet !

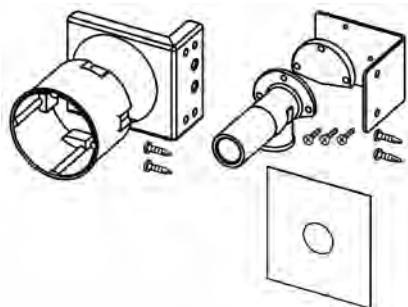

Washlet attachments:

e.g. TOTO washlet GL

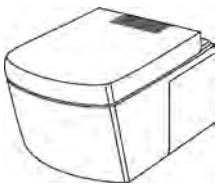

Upgrade set for wall-hung washlet attachments

The upgrade set (Order No. 9 880 037) is required in shell construction. It enables later installation of a washlet attachment, for instance a TOTO washlet GL. The upgrade set (Order No. 9 880 037) can be installed on any dry-wall module. For this purpose, at the shell construction stage the upgrade set consisting of cavity wall connector socket, water connection and the retaining plates is screwed to the side at the module and connected.

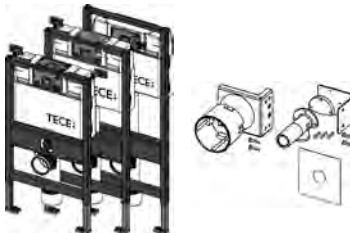
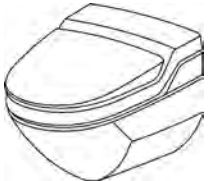
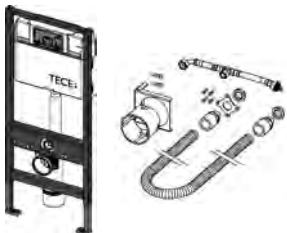
Washlet manufacturers	TECE Item
<p>TOTO Neorest LE/SE, wall-hung</p> 	<p>WC module for TOTO Neorest, overall height 1120 mm 9 300 044</p> 
<p>Washlet attachments e.g. TOTO washlet GL</p> 	<p>Dry-wall module, all heights + upgrade set for washlet attachments e.g. 9 300 000 + 9 880 037</p> 
<p>Geberit AquaClean® 4000 / 5000 / 8000 / 8000 plus</p> 	<p>Dry-wall module, overall height 1120 mm + upgrade set for wall-hung washlet e.g. 9 300 000 + 9 880 034</p> 

Overview of TECE washlet solutions

Barrier-free construction with TECEprofil

Planning fundamentals

- DIN 18 040 – part 1 Planning fundamentals "Barrier-free building" in buildings and workplaces with public access
- DIN 18 040 – part 2 "Barrier-free dwellings" (describes the requirements for sanitary rooms for wheelchair users in dwellings, etc.)

Barrier-free WC system according to DIN 18 040 – part 1 in public buildings:

DIN 18 040 part 1 is definitive for the creation of a public barrier-free WC system. Because of the highest assumed disability of a person in the public area, the requirements are considerably higher than that in the private area.



Barrier-free WC system

Seat height	46 - 48 cm incl. seat
WC depth	Overhang at least 70 cm
Backrest	55 cm behind the front edge of the WC
Movement area to the sides	90 cm left and right
Movement area in front of WC	150 x 150 cm
Folding handrails	Left and right; upper edge of folding handrail at least 28 cm above seat height; folding handrail protruding at least 15 cm beyond WC; distance between the rails 65 – 70 cm
Toilet roll holder	Can be reached from the seat
Loading capacity of folding handrail	Concentrated load of 1kN at front end of arm handrail
WC flush	Reachable from sitting with hand or arm
Emergency call system	Mounted near the WC pan, can be reached from the WC pan sitting or lying, designed to be visually contrasting, can be found and recognised by touch

Requirements for a barrier-free WC system

Installation height top edge of basin	Height front edge max. 80 cm
Movement area in front of basin	150 x 150 cm
Ability to travel under	Can travel under for at least 55 cm, knee freedom 67 cm measured up to 30 cm behind front edge, can travel under across a width of 90 cm
Ability to travel under hand basin	Can travel under for at least 45 cm
Fittings	One-lever mixer or touch-free fitting only in combination with temperature limitation, water temperature at outlet max. 45 °C, distance between fitting and front edge of basin max. 40 cm
Mirror	At least 100 cm high, access must be possible sitting and standing, arranged immediately above basin.
Service items	Single-handed soap dispenser, paper towel dispenser, waste bin, hand drier, must be arranged in the area of the basin.
Clothes hooks	At a minimum of two different heights for sitting and standing persons

Requirements for a barrier-free basin system



Basin module with flush-mounted trap, with mounting plates for safety support arms

A senior-citizen and disabled toilet system sets special structural requirements for the installation system. In order to resist the increased torque from the handles or safety support arms needed, as well as from the extended toilet, they must be secured in a special way. The TECEprofil modules are constructed so solidly that there is the facility to secure handles or safety support arms as well as the longer toilet with only two additional fixings.

Barrier-free WC system in a TECEprofil wall

Just one TECEprofil mounting plate (Order No. 9 042 003) is required per rail to secure the handrails or supports in a TECEprofil wall.

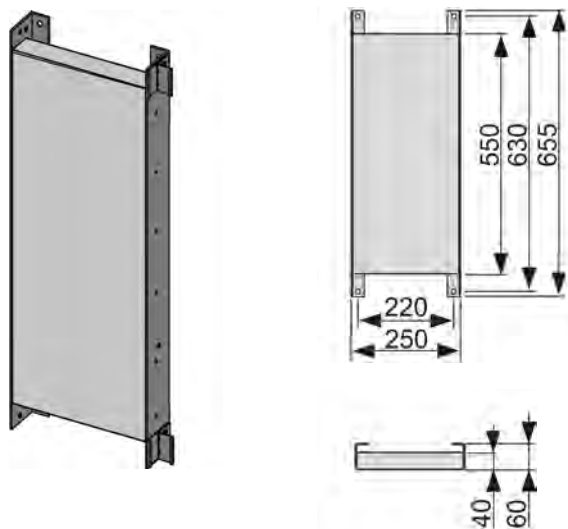

Mounting plate for handle and support arm systems (9 042 003)

The mounting plate can be bolted directly to the universal module and is equipped with multi-clips for securing to profiled tubes. The mounting plate must be secured to the solid wall with the TECEprofil modular attachments. The mounting plate is provided with the appropriate holes for this purpose. Furthermore, extra TECEprofil modular attachments (Order No. 9 380 000) are required in the area of the WC pan of the TECEprofil universal module.

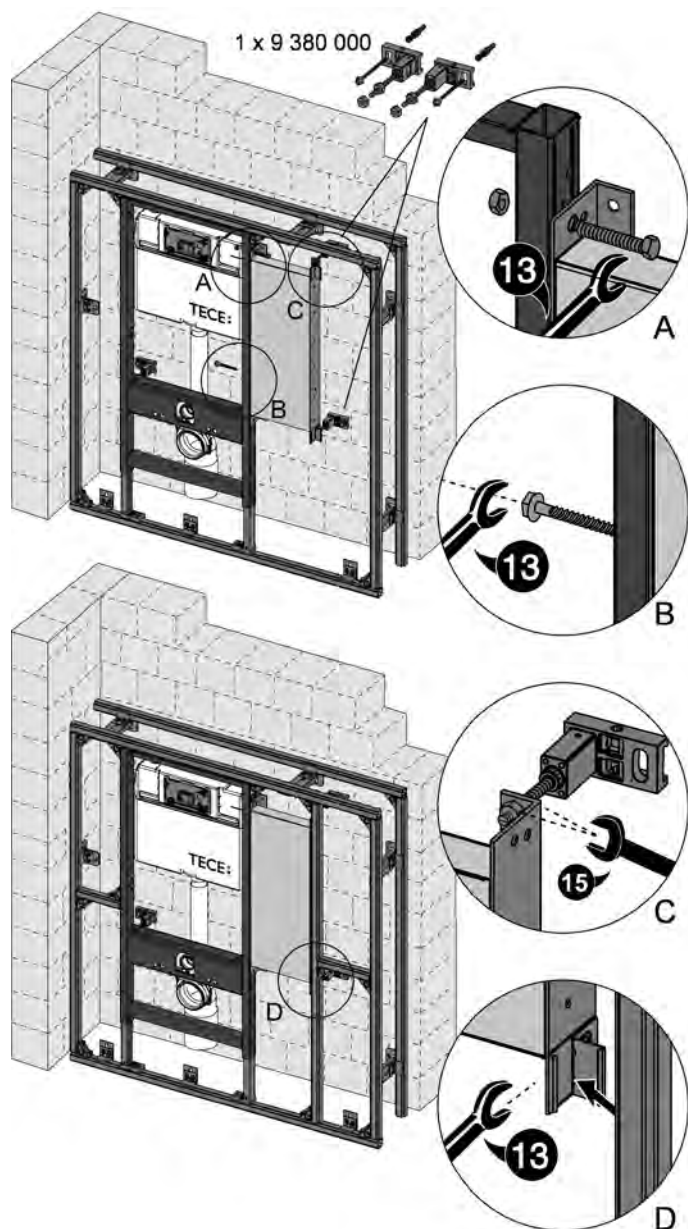

Installation of mounting plates for folding handrails with wall fixing (above) or multi-clips and profiled tube (below)

Barrier-free toilet system in individual construction

One of the TECEprofil universal modules for handrail and support systems (Order No. 9 360 000) is installed for each handrail. Furthermore, an extra TECEprofil modular attachment (Order No. 9 380 000) is required in the WC pan area of the TECEprofil universal module. This measure is sufficient to satisfy the increased structural demands of a barrier-free WC system.

The WC module and the handrail module are prepared for installation on UA profiles (50 size).

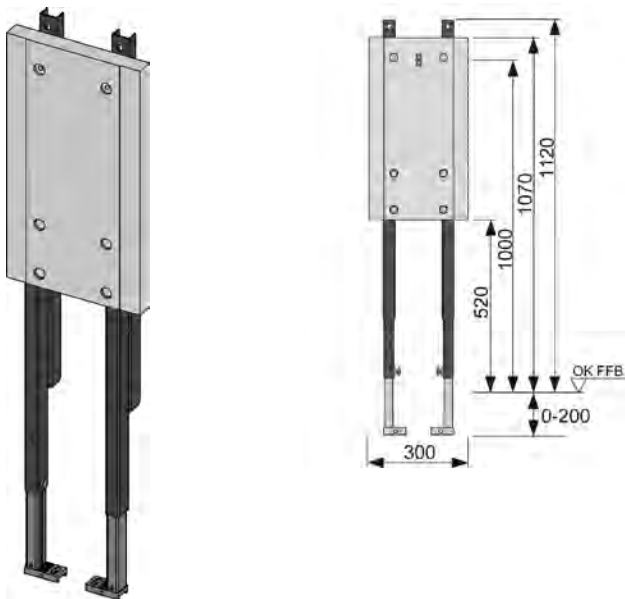

Module for handrail and support system (9 360 000)

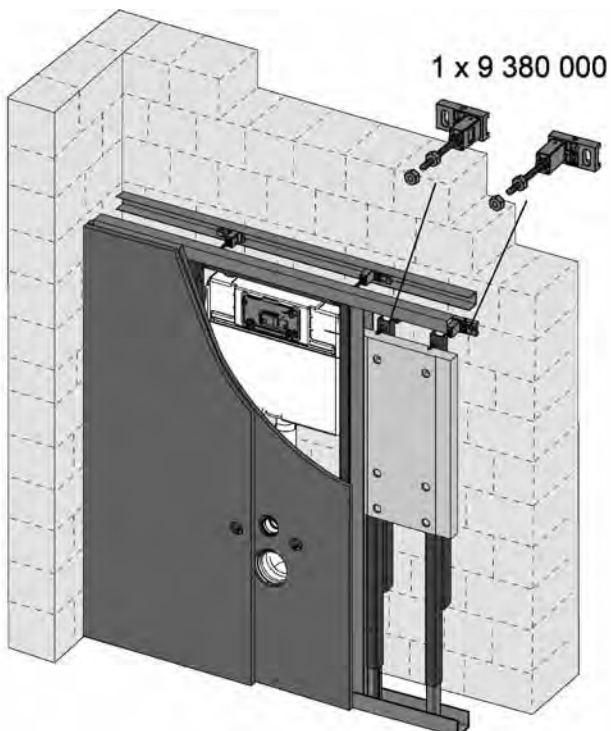

Installation of the module for handrail and support system with UA-profile in front of a solid wall.

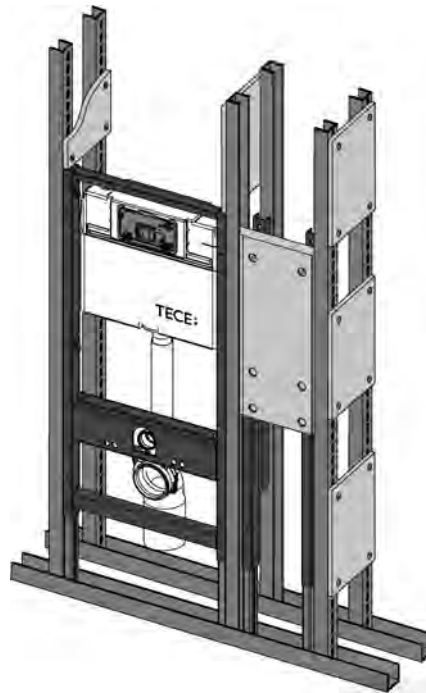

Installation of the handrail and support system module in a free-standing wall with UA-profile

TECEprofil Geronto module

The Geronto module (Order No. 9 300 009) is based on the TECE WC universal module. It has been specially developed for installation in barrier-free WC systems.

All the required heights and widths from DIN 18 040-1 for creation of a barrier-free WC system in public buildings are found again in this module. The crossbeam for fixing the WC is 5 cm higher than in the standard module. The standard overall height of the pre-wall thus remains unchanged.

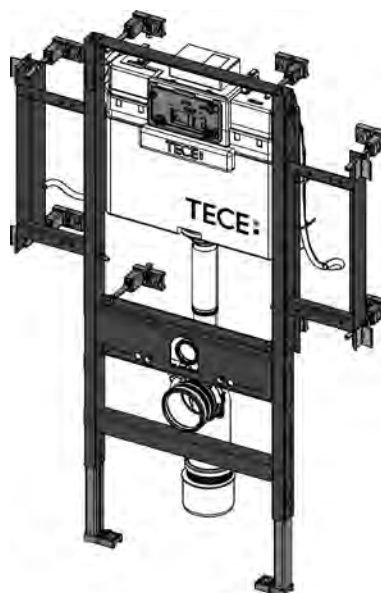

TECE Geronto module (9 300 009)

The steel side plates for mounting the folding handrails correspond exactly to those heights and widths requirements given in DIN standard 18 040-1 for installing folding handrails. The steel side plates are easy to install. They are bolted to the basic frame using only four mounting bolts. It does not matter which handrail manufacturer's equipment will be installed, the dimensions are always correct.

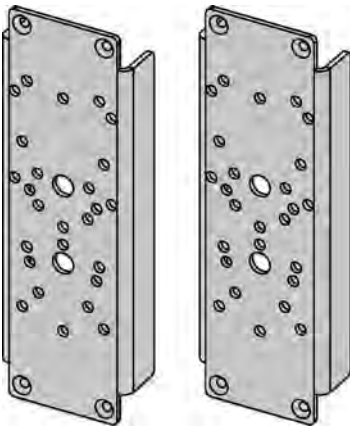

Steel plate set, suitable for handrails from most manufacturers

The steel side plates for mounting the folding handrails are available in various sets for the different manufacturers' equipment and must be ordered separately. The modular system allows handrails from practically all manufacturers to be installed. Because the toilet module and the steel plates are separate, the system retains its flexibility.

The cabling for the electronic flush actuation is easily installed due to the conduit provided as standard. The conduit finishes at the top face of the tank and can be reached at any time via an inside opening tank cover. Furthermore, the electric socket screwed to the tank cover makes it easy to wire up the electronics neatly. If servicing is required, the cables and electronics are accessible at all times.

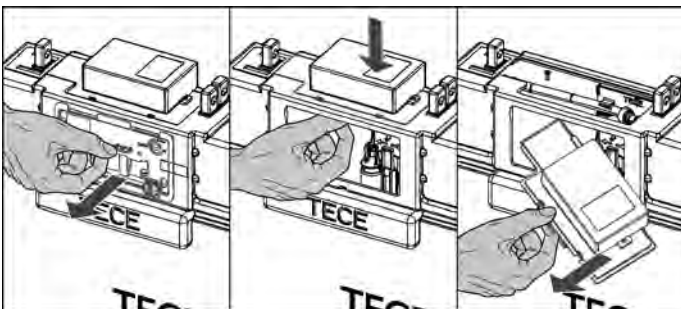

Electric socket for wiring up on the tank top, can be taken out from inside

With the TECEplanus WC electronics, TECE offers three flush actuation options to match the cistern: Cable, wireless or infra-red actuation. All three versions are available with battery or mains operation. The electronic actuation unit works with a servo-motor that is operated with commercially

available 6 volt lithium batteries or a 12 volt power supply unit. The flush is actuated by either a button in the folding handrail or on the wall.

Installation options of the Geronto module

The Geronto module can be used in different applications:

- Installation in a TECEprofil pre-wall
- Installation as an individual module in front of a solid wall
- Installation in a steel post-and-beam wall

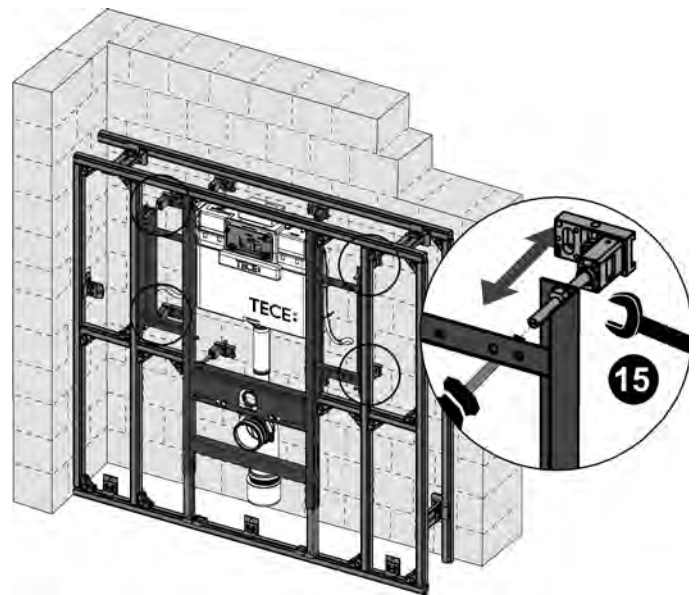

Installation in a TECEprofil pre-wall

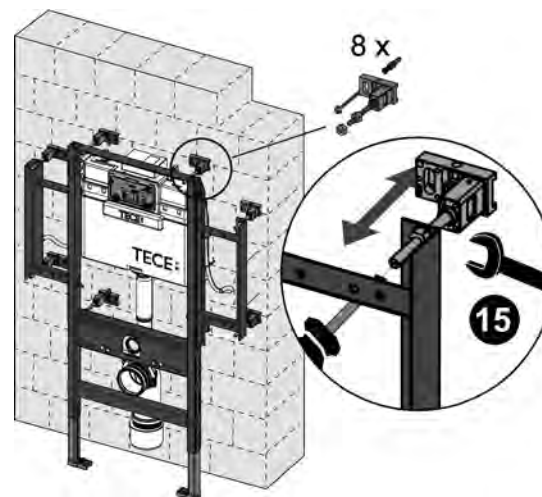

Installation as an individual module in front of a solid wall

TECEprofil – barrier-free construction

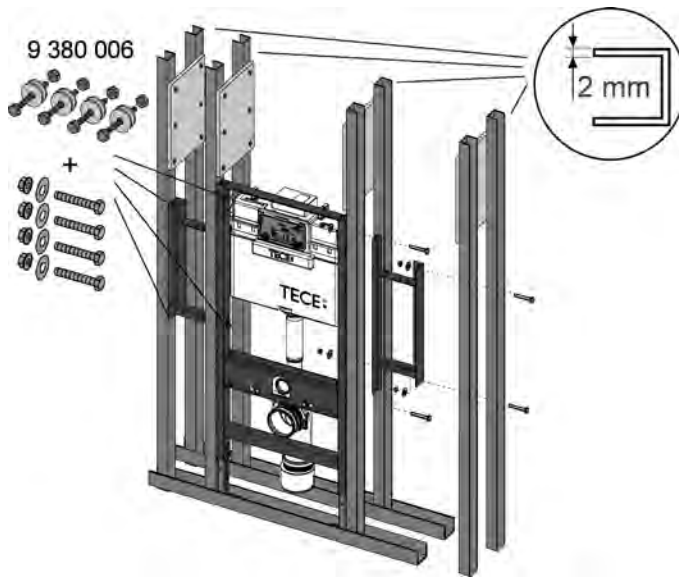

The conduit for cable actuation must be connected with the steel plate and the supplied screw fittings. Secure retention of the conduit during the whole building phase is therefore ensured. The mounting plates must always be supported on a structural shell which is able to take the load, using the supplied wall attachments.

Installation in a steel post-and-beam wall

Installation of steel plate set 9 042 xx on Geronto module 9 300 009

The steel plate set belongs to the modular system of WC Geronto module 9 300 009. This set must be ordered to suit the handrails which are to be installed.

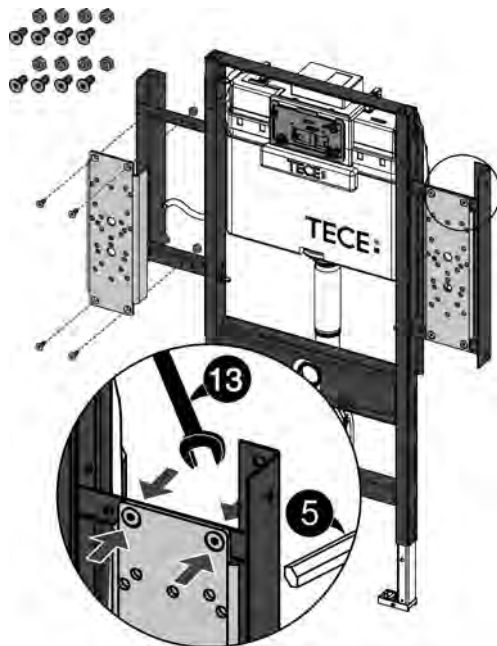

Installation of the steel side plates on the Geronto module

On the installed WC Geronto module, there are steel supporting frames at the sides for mounting the steel plate set. The steel plate set is bolted to the steel frame using four mounting bolts. Depending on the mounting points of the folding handrail, threaded plugs must be screwed into the appropriate threads. The exact position of the supported handrails is given in the installation instructions. Later drilling of mounting points during completion work is not necessary.

Sound insulation

Insulation against plumbing noise is becoming increasingly important in plumbing and heating technology. During development of the TECEprofil pre-wall elements, special attention was paid to the sound insulation requirements. TECE products also allow the increased demands for structural sound insulation to be met.

Not only the properties of the product, but planning tasks such as floor plan layout and the weights of walls are also very important.

Relevant standards

Table 4 from DIN 4109/A1:2001-01 describes the values for the permitted noise level in rooms in need of protection against noises caused by housing technology systems. The values listed here are acknowledged as generally accepted engineering standards and always apply if no other agreement has been reached on sound insulation.

Table 4 from DIN 4109/A1: 2001-01

Column	1	2	3
Line	Noise source	Type of room needing protection	
		Living and sleeping spaces	Classrooms and work-spaces
		Characteristic noise level in dB(A)	
1	Water installations (water supply and drainage systems together)	$L_{ln} \leq 30$ ^{a)b)}	$L_{ln} \leq 35$ ^{a)}
2	Other building service systems	$L_{AFmax} \leq 30$ ^{c)}	$L_{AFmax} \leq 35$ ^{c)}
3	Operating days 06:00 to 22:00	$L_r \leq 25$	$L_r \leq 35$ ^{c)}
4	Operating nights 22:00 to 06:00	$L_r \leq 25$	$L_r \leq 35$ ^{c)}

- a) Single short peaks which occur when operating the fittings and devices according to table 6 (opening, closing, changing over, interrupting etc.) are not to be considered at the present time.
- b) Works and services contract conditions for meeting the permitted plumbing noise level:
The final planning documents must take into account the sound insulation requirements, among other things this means that the components must have the appropriate sound insulation certification. In addition, the responsible construction management must be named and called in to take part in the closing off or cladding of the installation. Further details are regulated by the ZVSHK information sheet (obtainable from: ZVSHK (German Central Association for Plumbing, Heating and Air Conditioning), Rathausallee 6, DE-53757 St. Augustin).
- c) For ventilation systems, 5 dB(A) higher values are permitted, provided it concerns constant noise without noticeable single tones.

Source: DIN 4109/table 4: Values of permitted noise levels in rooms needing protection against noises caused by housing technology systems and commercial operations

The main features of table 4 of DIN 4109/A1:2001-01 are:

- Governs the requirements for structural sound insulation
- Sound insulation does not mean that noise must be completely prevented
- Requirements are different depending on the building use and the room use
- Individual short-term noise peaks during actuation of fittings and devices (opening, closing, resetting, interruption, etc.) are not taken into consideration
- Does not apply to single-family houses
- The building authority does however have requirements for minimum sound insulation in private living areas

The noise level requirements according to DIN 4109 refer to the "room needing protection" in a third-party living area.

Needing protection are:

- Living spaces (incl. hall-cum-living rooms)
- Bedrooms (incl. hotels and care homes).
- Classrooms
- Offices (except open-plan offices)

Not needing protection in the sense of DIN 4109 (only for plumbing noise) include for instance:

- Own living area
- The room in which the sanitary item causing the noise is located
- "Loud" rooms in third-party living areas (e.g. bathroom, kitchen)
- Rooms in which persons do not regularly stay (e.g. cellars, storage spaces)
- Open-plan offices

Increased sound insulation

At the least, the requirements for increased sound insulation should always be agreed under the specifications of the standards and the actual noise levels called for.

Because of the different requirements in the standards in information sheet 2 of DIN 4109: 1989-11 and VDI 4100: 1994-09, the single description "increased sound insulation" is ambiguous. To meet the requirements for increased sound absorption actually on site, the greatest care must be taken during the planning and implementation. In the standard itself, consultation with a specialist in building acoustics is stipulated for this purpose.

Overview of acoustics standards

Acoustic standard	Protected areas		Max. permitted plumbing noise level			
			Standard	Increase sound insulation ¹⁾		
				Sound insulation level I	Sound insulation level II	Sound insulation level III
DIN 4109/A1 Corresponds to the generally accepted engineering standard (recommendation: agree generally in works and services contract)	space requiring sound insulation, lying diagonally below in third-party area		$L_{in} \leq 30 \text{ dB(A)}$	-	-	-
	neighbouring space requiring sound insulation in own area		no requirement	-	-	-
supplement 2 to DIN 4109/A1 ¹⁾ (agreement in works and services contract needed)	space requiring sound insulation, lying diagonally below in third-party area		-	$L_{in} \leq 25 \text{ dB(A)}$	-	-
	neighbouring space requiring sound insulation in own area		-	no requirement	-	-
VDI 4100 ¹⁾ (agreement in works and services contract needed)	space requiring sound insulation, lying diagonally below in third-party area		-	-	$L_{in} \leq 30 \text{ dB(A)}$	$L_{in} \leq 25 \text{ dB(A)}$
	neighbouring space requiring sound insulation in own area		-	-	$L_{in} \leq 30 \text{ dB(A)} 2)$	$L_{in} \leq 30 \text{ dB(A)} 2)$

1) If increased sound insulation is required, then the standard and the exact numeric value of the increased sound insulation must be explicitly agreed in the works and services contract.

2) Caution: According to VDI guideline 4100, increased sound insulation in own area counts automatically as agreed in a works and services contract.

TECEprofil system sound-proofing measures

Particular attention was paid to sound insulation during development of TECEprofil. For instance, the transmission of sound waves has been reduced in a targeted manner by the use of special acoustic insulation components. In cooperation with various renowned institutes, different constructions were tested. The acoustic properties according to DIN 4109 were confirmed by expert assessment.



Sound insulation of crossbeam from module frame

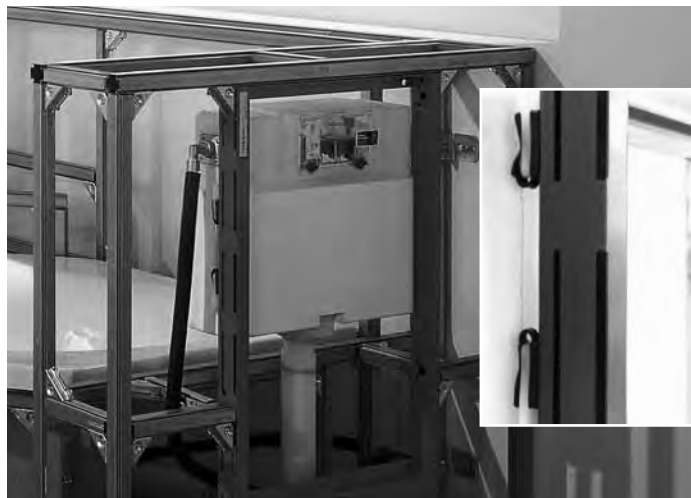

Sound insulation of cistern from module frame

Should you have any questions about structural sound insulation, also including in relation to a project, we would be pleased to help. Expert report and statement available on request.



Fraunhofer Institut Bauphysik

MPA NRW
Materialprüfungsamt Nordrhein-Westfalen

KÖTTER
CONSULTING ENGINEERS

TECEprofil noise-protection verification

Plumbing noise level L_{in}

Example:

For the experimental construction, a TECEprofil pre-wall was installed in front of a structural shell wall according to DIN 4109. The noise from the installation was measured in a room lying diagonally below the installation room.

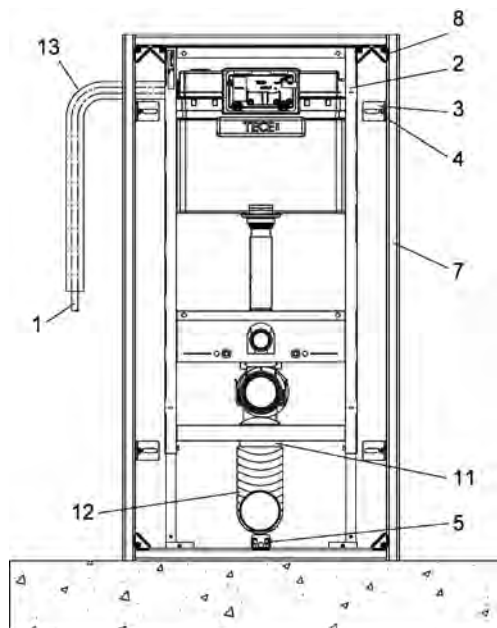

Experimental construction with TECEprofil pre-wall and WC module

A standard HT pipe was used for the insulated waste pipe (12). The condensation-protected fresh water pipe (13) was created using TECEflex (1). TECEprofil sound insulation set (Order No. 9 200 010) was installed to sound-proof the WC ceramics. All angle brackets (3) of the TECEprofil pre-wall were provided with a sound insulation set (4) (Order No. 9 021 019). The TECEprofil universal module (Order No. 9 300 000) was equipped with the TECE cistern (2). The standard volume of 6 litres was flushed. The filling time was 90 seconds.

Plumbing noise level L_{in} according to DIN 52 219 and DIN 4109 in dB(A)

Excitation	Measuring room rear lower floor (diagonally below the installation room)
TECEprofil universal module with TECE cistern	19 dB(A)

The acoustic data is based on measurements made by the Fraunhofer Institute for Building Physics in Stuttgart. The measurements were taken on the basis of German standards and directives under practice-orientated conditions.

Item	Item name	Item number
Shell construction installation		
1	TECEflex composite pipe 16 mm	7 320 16
2	TECEprofil WC module	9 300 000
3	TECEprofil double bracket	9 030 011
4	TECEprofil sound insulation set for angle bracket	9 021 019
5	TECEprofil angle bracket	9 030 002
6	TECEprofil panel, 18 mm	9 200 000
7	TECEprofil profiled tube	9 000 000
8	TECEprofil corner joint	9 010 002
9	TECEprofil knifing filler	9 200 002
10	TECEprofil panel screws	9 200 001
11	HT waste pipe DN 100	-
12	Adhesive felt bandage	-
Fine installation		
13	TOTO deep flush WC ceramic	
14	TECE sound insulation set for WC	9 200 010
15	TECEambia WC push plate	9 240 200

TECEprofil list of components

All data relates to the structural relationships and the installation conditions shown which are found in the plumbing test rig at the Fraunhofer Institute for Building Physics. The test rig represents a section from a typical residential building and can be used as direct verification of building authority sound insulation requirements. Other structural data may lead to different results.

The influence of the wall mass on the plumbing noise level

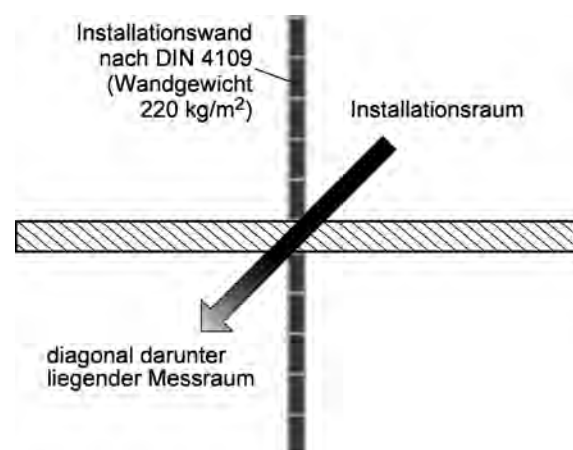

Location of installation and measuring rooms

The graph shows the change in plumbing noise in the room lying diagonally below the installation room (rear lower floor) as a function of the mass per unit area of the installation wall for the same excitation noise. The plot shown is the noise level difference compared with an installation wall with a mass per unit area of $m'' = 220 \text{ kg/m}^2$.

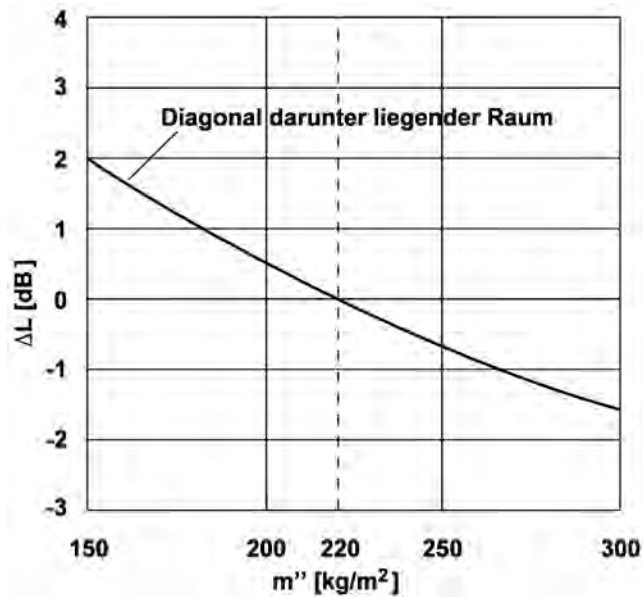

Change in the plumbing noise level – calculated results
(calculated by the Fraunhofer Institute for Building Physics, Stuttgart)

The calculated results shown refer to the relationships in the plumbing test rig at the Fraunhofer Institute for Building

Physics and cannot be directly applied to other building situations. To simplify the calculations, it was assumed that the thickness, inner damping and module of elasticity of the installation wall do not change.

Rated sound reduction index R'w

According to DIN 4109, general requirements for sound insulation apply to dividing walls in third-party living and working areas. Here this concerns the value known as "Rated sound reduction index" R'w. The rated sound reduction index R'w characterises the airborne sound reduction by components.

Extract from DIN 4109

Sound insulation of dividing walls between third-party living or working areas, rated sound reduction index R'w between two rooms; requirements according to DIN 4109 as well as suggestions for increased sound insulation according to DIN 4109 supplement 2:

Line	Description	Experienced rated sound reduction index R'w according to DIN 4109	
		Normal requirements	Increased requirements
1	Multi-storey buildings with apartments or workspaces - walls dividing apartments - walls between third-party workspaces - staircase walls, walls beside hallways	53 dB	55 dB
		53 dB	55 dB
		52 dB	55 dB
2	Accommodation facilities, hospitals, nursing homes - walls between rooms for overnight stays - walls between patients' rooms - walls between these and hallways	47 dB	52 dB
		47 dB	52 dB
		47 dB	52 dB
3	Schools and comparable educational buildings - walls between classrooms - walls between classrooms and hallways - walls between classrooms and staircases	47 dB	-
		47 dB	-
		55 dB	-

Sound insulation of dividing walls within own living or working area, rated sound reduction index R'w between 2 rooms; suggestions according to DIN 4109 supplement 2 for normal and increased sound insulation:

Line	Description	Experienced rated sound reduction index R'w according to DIN 4109	
		Normal requirements	Increased requirements
1	Residential building - walls without doors between "loud" and "quiet" rooms with various uses	40 dB	47 dB
2	Offices and administrative rooms - walls between rooms with usual office activities - walls between these and hallways - walls of rooms for concentrated intellectual activity	47 dB	52 dB
		45 dB	42 dB
		45 dB	47 dB

Test rig measurement "rated sound reduction index R'w" according to DIN 4109

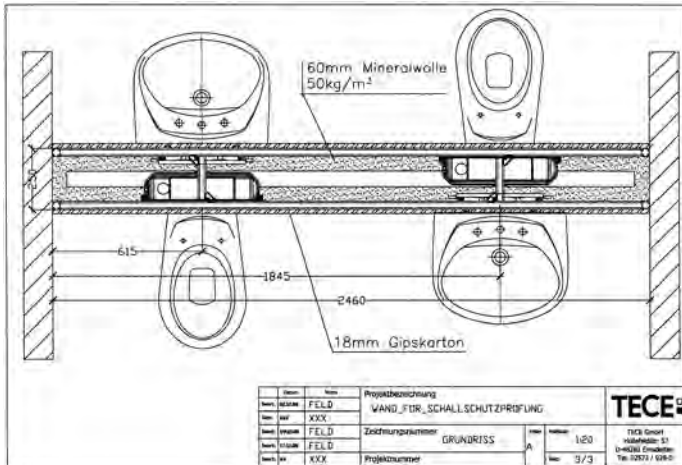

Construction of the tested TECEprofil dividing wall

An acoustics report has proved that dividing walls with the TECEprofil system meet sound insulation requirements. The room height TECEprofil dividing wall tested was allocated a cistern and a basin on both sides. The thickness of the unpanelled dividing wall was 250 mm. The inside cavity of the dividing wall was filled with 60 mm thick mineral wool (50 kg/m³) on both sides. The dividing wall was covered with 18 mm thick plasterboard panels, the joints between them were filled.

The rated sound reduction index R'w which was determined gave a test value of 52 dB(A). As a consequence, dividing walls made of TECEprofil incl. sanitary fixtures, for instance in hotels, schoolrooms or hospitals etc. are permitted.

Dividing walls between dwellings may not be created with the TECEprofil system !

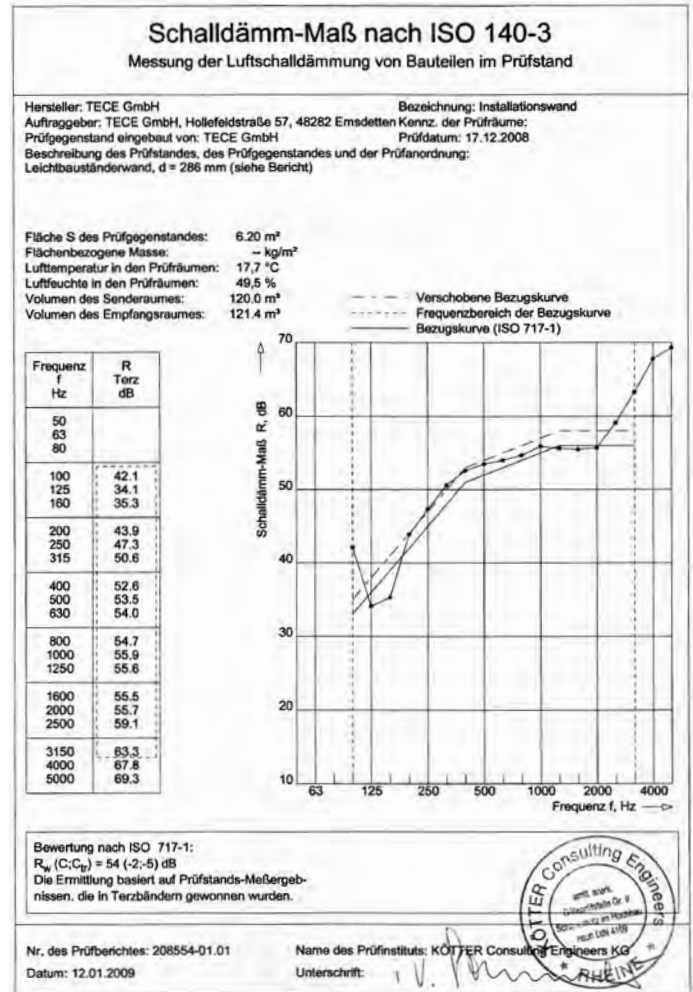

Extract from the test report

TECEprofil dry-wall construction system - sound insulation according to DIN 4109

TECEprofil pre-wall installation in front of a solid dividing wall made of sand-lime blocks with a weight per square metre of 220 kg/m²



Plumbing noise level	Standard requirements DIN 4109/A1	Increased requirements DIN 4109/supplement 2
$L_{IN} = 19 \text{ dB(A)}$	✓	✓

TECEprofil as room-closing dividing wall



Plumbing noise level	Standard requirements DIN 4109/A1	Increased requirements DIN 4109/supplement 2	Rated sound reduction index
$L_{IN} = 19 \text{ dB(A)}$	✓	✓	$R'_w = 52 \text{ dB(A)}$

TECEprofil pre-wall installation in front of a dry-wall construction dividing wall (Knauf & Co., W112)



Plumbing noise level	Standard requirements DIN 4109/A1	Increased requirements DIN 4109/supplement 2
$L_{IN} = 19 \text{ dB(A)}$	✓	✓

TECEprofil in a room-closing dry-wall construction (Knauf & Co., W116)



Plumbing noise level	Standard requirements DIN 4109/A1	Increased requirements DIN 4109/supplement 2
$L_{IN} = 19 \text{ dB(A)}$	✓	✓

TECEbox brick-wall construction system - sound insulation according to DIN 4109

TECEbox 9 370 000/9 375 000 in front of a solid dividing wall made of sand-lime blocks with a weight per square metre of 220 kg/m²



Plumbing noise level	Standard requirements DIN 4109/A1	Increased requirements DIN 4109/supplement 2
$L_{IN} = 29 \text{ dB(A)}$	✓	-

TECEbox plus 9 371 000 incl. building area covering 9 200 012



Plumbing noise level	Standard requirements DIN 4109/A1	Increased requirements DIN 4109/supplement 2
$L_{IN} = 28 \text{ dB(A)}^*$	✓	-

* the cavity below the cistern and the cavity in the outlet area must be filled with mineral wool for this purpose !

Fire protection

TECEprofil room-dividing walls with fire protection requirements

With the TECEprofil system, non-load bearing room-closing dividing walls with fire protection specifications from F 30–F 120 can be created, which basically consist of a steel post-and-beam wall (TECEprofil), two-sided panelling of plasterboard, sanitary fixtures and an insulation material. The room-dividing walls may be implemented with any wall width and a maximum wall height of 4.5 metres. The structural certificate for the wall constructions was produced by the MPA in Braunschweig.

No special components are needed for the TECEprofil supporting frame. All standard components from the TECEprofil system can be used. The single-layer 18 mm thick TECE system panelling or alternatively 2 x 12.5 mm thick plasterboard can be used for panelling.

Depending on the fire resistance class needed, the walls must be built according to the specifications and packed with mineral wool. For specifications F 90 and above, the dividing wall must always be fully packed with mineral wool over its whole area (melting point > 1000 °C). The thickness of the wall must be taken into account.

Construction of a dividing wall (F 30 – F 120)

The dividing wall must be divided up into vertical box sections according to the width of the wall. A box section must not be wider than 1 metre. The maximum permitted height of a box section is limited to 4.5 metres. The vertical profiled tubes of neighbouring box sections are drilled and secured together using threaded bolts. This type of mounting considerably simplifies the prefabrication and on-site installation. Single box sections can easily be put together to form a dividing wall. The wall must be secured all-round to a solid wall. The distance between fixings into the wall, ceiling and floor must not exceed 0.6 metres. If there are any deviations from the tested construction, then the TECE Service Department must always be consulted. Minor changes during construction are possible but they must however be approved by TECE.

Quick overview of the construction variants F 30–F 120

The required fire specification has a great effect on the construction thickness and its fixtures. The following table provides a simplified overview of the differences between the fixtures.

Resistance time	F 30	F 30	F 60	F 90	F 120
min. wall thickness incl. panelling (mm)	286	386	286	386	386
max. height (m)	4.5	4.5	4.5	4.5	4.5
max. width	n.l.*	n.l.*	n.l.*	n.l.*	n.l.*
Packing only in the area of the fixtures	No	Yes	No	No	No
Packing of the complete wall required	Yes	No	Yes	Yes	Yes
Standard flush mounted electric socket	Yes	Yes	No	Yes	Yes
Water meter	Yes	Yes	No	Yes	No
Fan installation	Yes	Yes	Yes	Yes	Yes
Cooling pipes	Yes	Yes	Yes	Yes	Yes
Plasterboard 1 x 18 mm or 2 x 12.5 mm	Yes	Yes	Yes	Yes	Yes
Shower channels	Yes	Yes	Yes	Yes	Yes
Wood panels	Yes	Yes	Yes	Yes	Yes
Single-sided building layout	Yes	Yes	Yes	Yes	Yes
Double-sided building layout	Yes	Yes	Yes	Yes	Yes
KF ball-and-socket pipe, max. DN 125	Yes	Yes	Yes	Yes	Yes
SML pipe, max. DN 125	Yes	Yes	Yes	Yes	Yes

* no limit

Mineral wool:

TECEprofil room-dividing walls for which fire protection specifications are stipulated, depending on the fire resistance class required, must be packed with mineral wool (melting point > 1000 °C). Only the following mineral wool types are permitted for packing TECEprofil room-dividing walls with fire protection specifications:

- Rockwool: Termarock 50 and Rockwool RL Loose Fill
- Isover: Protect BSP 50 and Isover SL mineral wool
- TECE: TECEprofil fire protection panel set (9 200 017)

Packing the walls:

For the F 30 requirements, there are two possible ways in which a room dividing wall with fire protection specifications can be suitably packed.

1) Minimum distances between the insulation for F 30 requirements

Sanitary fixtures	Minimum distance above/below (mm)	Minimum distance left/right (mm)
Ventilation box	≥ 171	≥ 192
Fittings crossbeam (shower)	≥ 176 header top edge	≥ 243.5
Shower channels	≥ 154 header top edge	≥ 265 ≥ 412
Basin crossbeam	≥ 308 ≥ 417	≥ 223
Socket/flush-mounted box	≥ 166	≥ 166
Water meter	≥ 240.5	≥ 322
WC module	≥ 196.5 ≥ 555	≥ 217

2) Simplified rule for packing F 30 dividing walls

The following simplified rule gives the correct practice for packing the fixtures in a F 30 room dividing wall:

- The wall must be packed throughout and over the whole surface for 0.5 m from the unfinished floor. Horizontal drainage pipes may only be laid in the insulated area of the wall.
- All fixtures within in a circle of 30 cm from the outer edge of the wall breakthrough must be insulated.
- A fire protection set must always be installed in the area of every WC module. The cavities at the WC module must be fully packed.
- Attention must be paid to the dimensions between the insulation for back-to-back mounting of fixtures.



Packing for F 90/F 120 requirements

For fire protection specifications F 90 and above, the dividing wall must always be fully packed, tightly and without cavities. For WC fixtures, a fire protection panel set must always be installed for each WC. Only the listed mineral wools/packing wools from the manufacturers named above may be used to pack the room dividing wall.

Example constructions:



F 90 from 386 mm wall thickness



F 90 from 286 mm wall thickness

Panelling

The panelling may be with the 18 mm thick TECEprofil system panelling or alternatively with 2 x 12.5 mm thick plasterboard (type GKBi). With double panelling, both panel faces must be completed with a panel offset of < 400 mm. Joints opposite each other must be avoided when building the wall. The size of the panels must be limited to < 1350 mm x < 625 mm. To secure the panelling, 3.5 mm x 35 mm screws must be used, at a distance of < 150 mm apart. The joints must be filled with TECEprofil knifing filler.

Fixtures

Taking into consideration each technical regulation (e.g. the building regulations) and fire resistance period, the following fixtures may be used:

- a) fan housing with F 90 fire protection housing and maximum outside dimensions of 249 x 249 mm, distance between backs $a \geq 160$ (wall $t \geq 386$ mm) or $a \geq 46$ mm (wall $t \geq 286$ mm)
- b) installation boxes for water fittings (e.g. Hans Grohe i-box)
- c) shower channels, e.g. TECEdrainline
- d) connection units and modules e.g. for basin, bidet, urinal etc.
- e) WC module with TECE cistern, with back-to-back installation, minimum distance apart $a \geq 56$ mm
- f) mounting plates made of building plywood, e.g. for mounting folding handrails, max dimensions (w x h x d) = 215 mm x 550 mm x 40 mm
- g) insulated water meter units with shut-offs, max. dimensions w x h = 290 mm x 290 mm, depth d = 70 mm, distance apart for back-to-back installation of the housing $a \geq 210$ mm (wall $t \geq 386$ mm)
- h) flush-mounted electric socket without fire protection approval

Pipework

In TECEprofil room-dividing walls with fire protection specifications, the most varied pipe materials may be used. No special manufacturers are specified here. The following pipe materials have been tested and authorised:

Ventilation pipes:

- Folded spiral seam pipe \leq DN 125 with steel braided pipes DN 80

Foul water and rain water pipes:

- Sound insulated plastic pipe up to DN 125
- SML cast iron pipe up to DN 125

Fresh water, heating and cooling pipes:

- Plastic pipes up to 63 mm (outside diameter)
- Multi-layer composite pipes up to 63 mm (outside diameter)
- Metal pipes made of copper or stainless steel up to 63 mm (outside diameter)

The insulation of pipes may be with foam insulation (e.g. rubber-based), aluminium-clad mineral wool (e.g. Rockwool RS 800) or corrugated tubes.

Electric cables

Individual cables are permitted to pass through the classified room-closing wall constructions provided that the remaining hole cross-section is completely closed with plaster.

Implementation of bundled electric cables requires compartmentalisation whose fire resistance class by testing according to DIN 4102-9: 1990-05 must be proven, further evidence of suitability is necessary, e.g. within the scope of the issue of a building authority authorisation.

Compartmentalisation is required for the horizontal implementation of pipes, plumbing channels, cable channels or ventilation ducts, whose fire resistance class by testing according to DIN 4102-11 : 1985-12, DIN 4102-12 : 1988-11 or DIN 4102-6 : 1977-09 must be proven. further evidence of suitability is necessary, e.g. within the scope of the issue of a building authority general authorisation or a building authority general test certificate.

Electrical sockets

Depending on the application, standard wall-mounted electrical sockets may be used, combined with packing at the rear with mineral wool.

Only exception: F 90 with a wall thickness ≤ 386 mm
Here a flush-mounted electrical socket with F 90 approval must be used

Fan fixtures

Fan boxes may be arranged in the dividing wall directly opposite each other or offset. Care must be taken that for all the required fire classes, only fan boxes with a F 90 approval may be used. The connection ducts to the fan and the riser ducts must always be made of steel.

If isolating equipment against the transmission of fire should be built into fan ducts with certain fire resistance classes, then the suitability of these fixtures in combination with the wall construction must be proven according to DIN 4102-5 : 1977-09, DIN 4102-6 : 1977-09 or DIN 4102-13 : 1990-05. Further evidence of suitability is necessary, e.g. within the scope of the issue of a building authority general authorisation.





TECEbox – brick-wall construction
Technical Guidelines



Description of the system	64
TECEbox	64
TECEbox installation	65
TECEbox installation – low installation height	66
TECEbox plus	68
TECEbox plus installation	68
TECEbox washstand	70
TECEbox washstand installation	70
TECEbox urinal flush valve housing	71
TECEbox urinal flush valve housing installation	71
Sound insulation	73
Sound insulation expert opinions for toilet modules of the TECEbox series	73

TECEbox – description of the system

Description of the system

TECE offers TECEbox series modules especially for brick-wall construction. In brick-wall construction, the TECEbox modules are bricked in with mortar or concrete. The modules are first installed and connected in front of a solid wall. The expert opinions from the Fraunhofer Institute in Stuttgart show that sound insulation is not neglected here. All brick-wall toilet modules meet the standard sound insulation requirements of DIN 4109/A1. The corresponding assessments can be provided by the TECE service department on request. As the modules are not self-supporting, they are not suitable for use in dry walls.

Standards for assumed loads, measurement, construction and building physics:

- DIN 1053-1 Masonry - Design and construction
- DIN 1053-4 Masonry - Prefabricated masonry compound units
- DIN 1055-1 Actions on structures - Densities and weights of building materials structural elements and stored materials
- DIN 1055-3 Self-weight and imposed load in building

TECEbox

The standard versions in the TECEbox series are available for the standard installation height or low installation height e.g. for installation below the window.



Brick-wall module TECEbox, standard height (order number 9 370 000)



Brick-wall module TECEbox, low height (order number 9 375 000)

The low installation height offers flush actuation from the top or front. The heart of the toilet brick-wall modules is as always the TECE cistern. This is characterized by its complete compatibility with all TECE push plates.

The surrounding steel frame ensures secure mounting in front of a solid wall. The two-part drain bend enables DN 90 or DN 100 waste water pipes to be connected. The adapter can also be used as horizontal outlet.

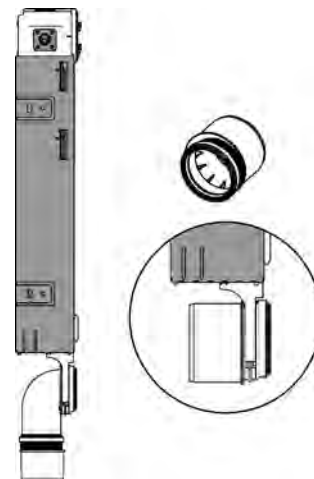

Two-part drain bend – also for horizontal connection

For the standard TECEbox installation height, optional assembly feet are available as an assembly aid (order number 9 030 024).



TECEbox assembly feet (order box 9 030 024)

TECEbox installation

Align TECEbox in front of the solid wall and screw it on to the clips (top) and brackets (bottom).

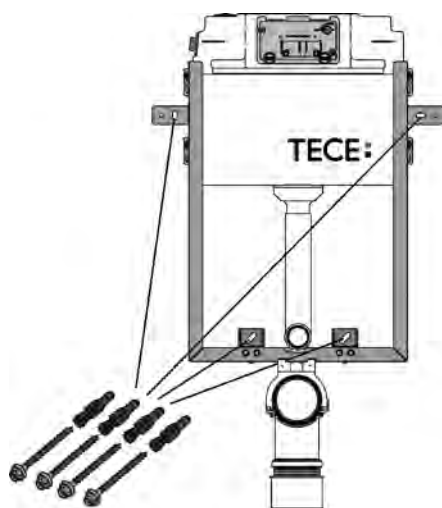

The module must be completely bricked in and all hollow spaces filled. Fit the bare-wall protection and threaded rods.

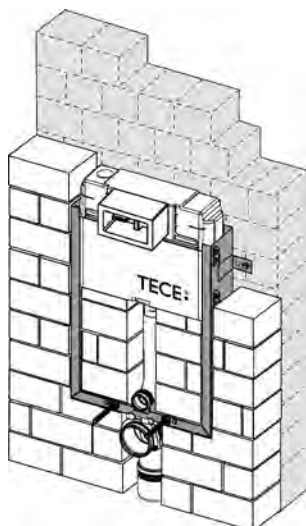

Now attach the expanded metal – see diagram.

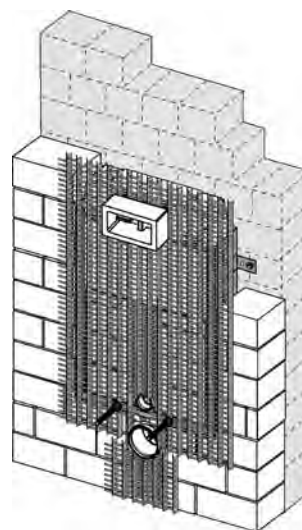

You can then apply the plaster and tile the surface.

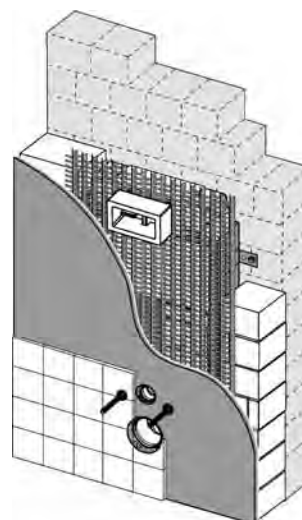

The wall must be at least 18 and no more than 100 mm thick.

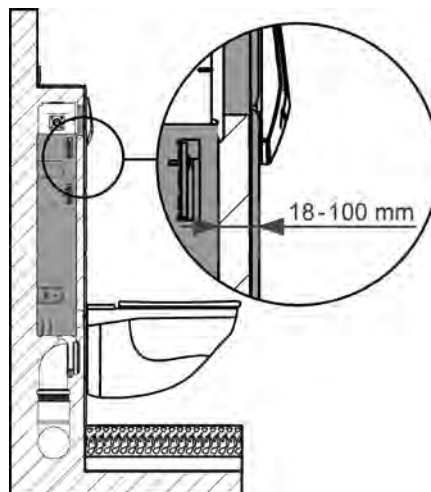

TIP!

Installation in rows with TECEbox is made easier using TECEprofil pipe and angle brackets. The brick-wall construction frames can be easily positioned on the TECEprofil pipe through the side slot in the steel frame and fixed using the angle brackets. This makes alignment easier. In this case, the modules then only have to be screwed to the wall by means of the two top fastening clips.

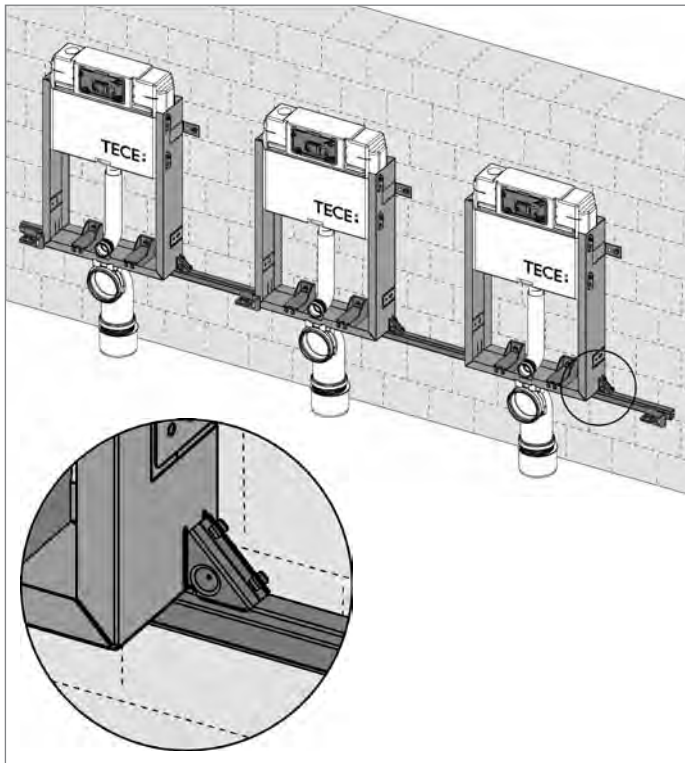

Installation of TECEbox in rows – with TECEprofil pipe and angle brackets

TECEbox installation – low installation height

TECEbox for a low installation height must be aligned in front of the solid wall and screwed on to the clips (top) and mounting brackets (bottom).

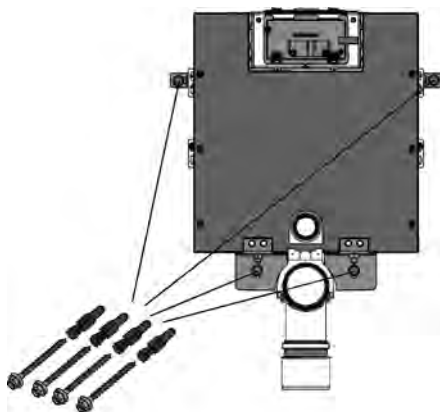

Set the required distance from the wall at the four depth-adjustable distances.

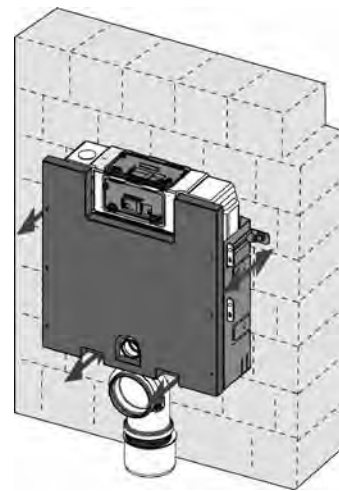

Actuation from the top:

For actuation from the top, a minimum distance of 200 mm from the wall to the top edge of the module must be ensured. The front structural board serves as the minimum projection and must not be removed, as this prevents the push plate protruding later.

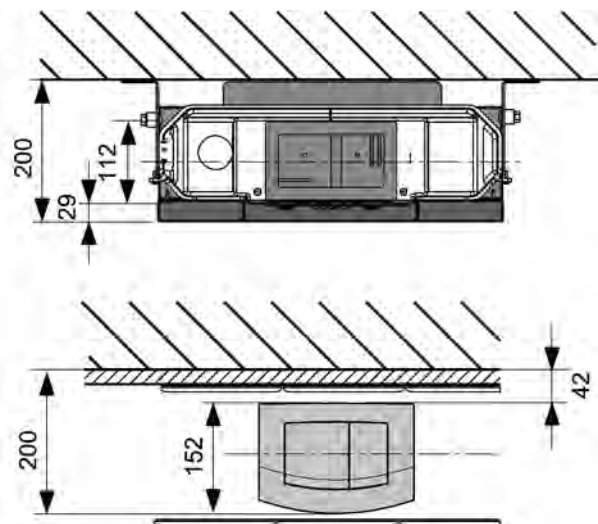

Actuation from the front:

For actuation from the front, the minimum installation depth of the toilet module is 160 mm.

The module must be completely bricked in and all hollow spaces filled. Fit the bare-wall protection and threaded rods. Now attach the expanded metal – see diagram.

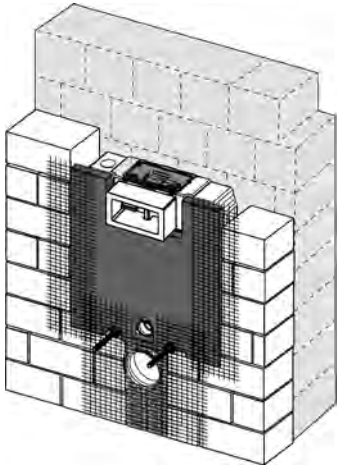

You can then apply the plaster and tile the surface.

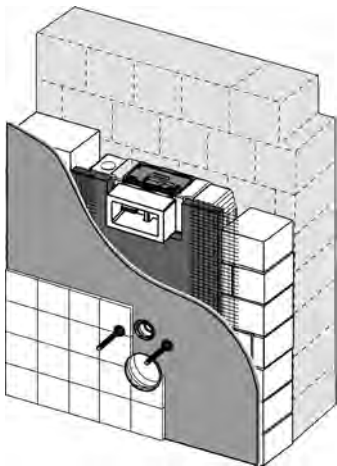

The wall must be at least 18 and no more than 100 mm thick.

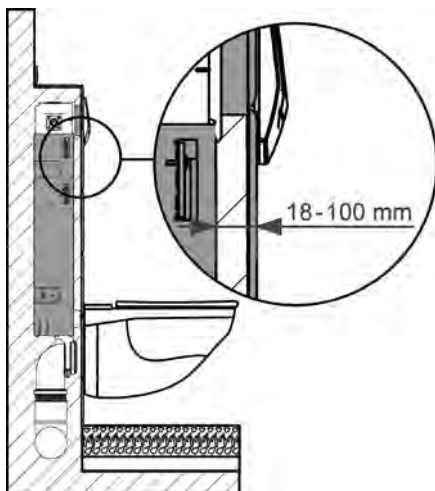

Note:

If the push plate is fitted in front and a compact ceramic system is used in the case of cisterns with a low assembly height, the toilet lid may occasionally drop down unintentionally. As a result, when a compact ceramic system is used, actuation should be from the top only.

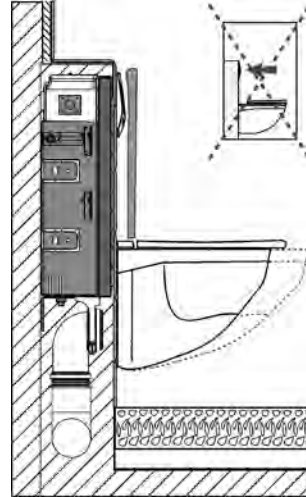

TECEbox plus



Brick-wall module TECEbox plus (order number 9 371 000)

TECEbox plus is a brick-wall module installed in front of a solid wall. It is characterized by a closed surface, and time-consuming bricking-in of the cistern is thus not required. With the assembly area cover available as an accessory, a continuous surface of glass-fibre lightweight concrete is produced on the front, which can be directly tiled.

TECEbox plus installation

Thanks to the premounted steel feet, TECEbox plus can be easily set in front of the wall and to the required height. With the depth-adjustable wall attachments, TECEbox plus can be easily aligned and attached.

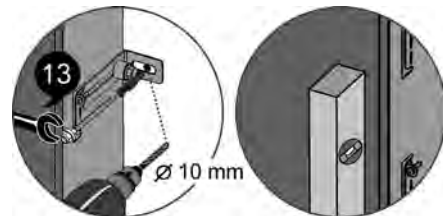
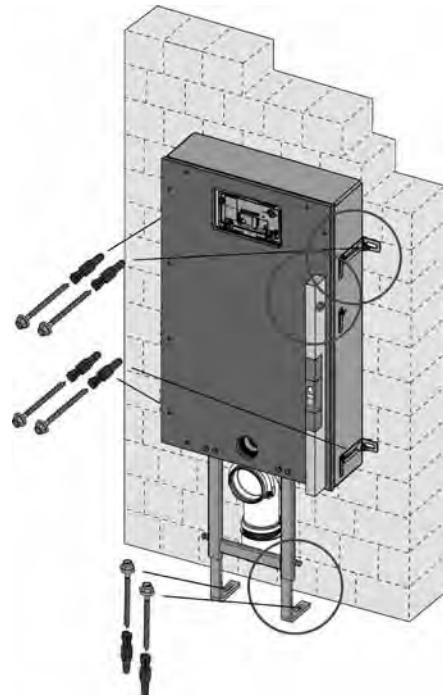

The feet are screwed to the floor.

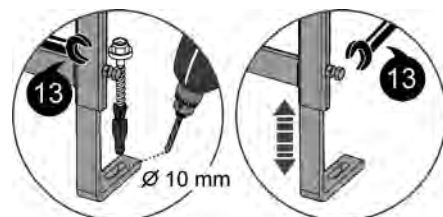

If the optionally available assembly area cover is used, the lower assembly area must not be lined. Installation of the lower assembly area cover (order number 9 200 012) is simple and a continuous, tileable surface is also immediately produced.

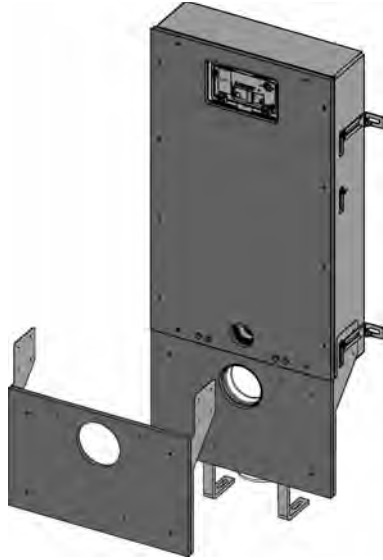

Note:

If sound insulation requirements in accordance with DIN 4109 must be met, the hollow space below the cistern and the drainage area must be filled with mineral wool on the construction site.

At the transition points from the glass-fibre lightweight concrete slab to the masonry, reinforcing tape must be included to avoid possible tile cracks. The surface can then be tiled.

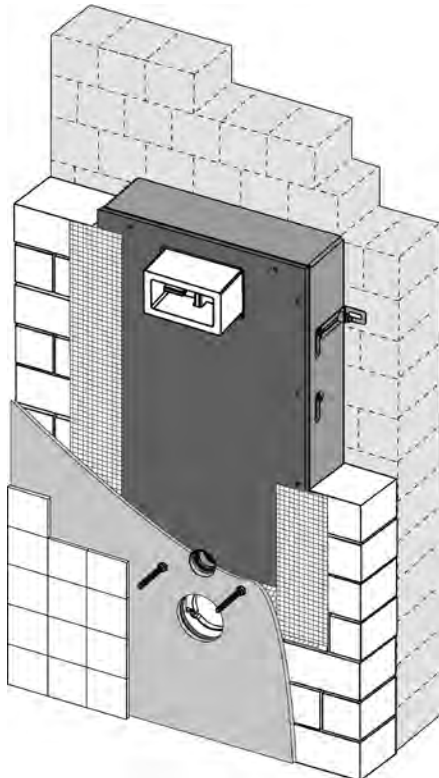

TECEbox washstand



Washstand TECEbox (order number 9 370 033)

The connections for washstands in a brick-wall construction can be easily installed with the washstand frame. The surrounding 8 cm deep steel frame with four depth-adjustable wall attachments is simply attached to each solid wall. All connection dimensions must be defined prior to bricking-in, and the elements fixed accordingly. A subsequent change to the installation dimensions is not possible.

TECEbox washstand installation

In the first step, the module is attached to the solid wall and horizontally aligned. The appropriate depth is set via the four wall attachments. The height-adjustable drain bend holder and depth-adjustable drain bend can be used for practically every application case. The DN 50 drain bend can also be shortened to a dimension of DN 40.

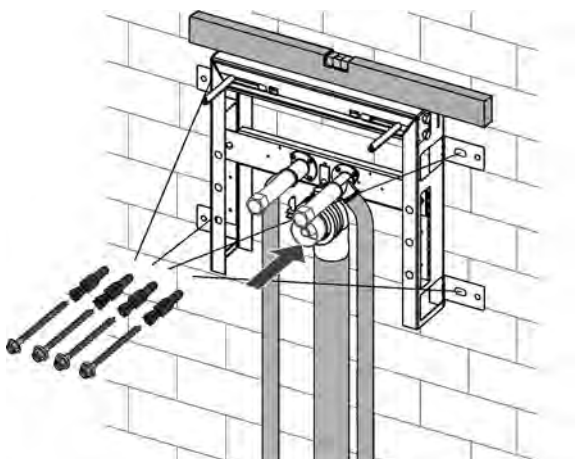

The distance from the threaded rods to the washstand ceramics retainer can range from 170 to 280 mm.

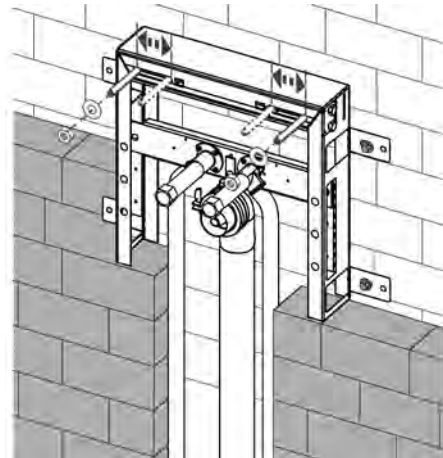

After installation and connection of all connection pipes, the module is bricked in.

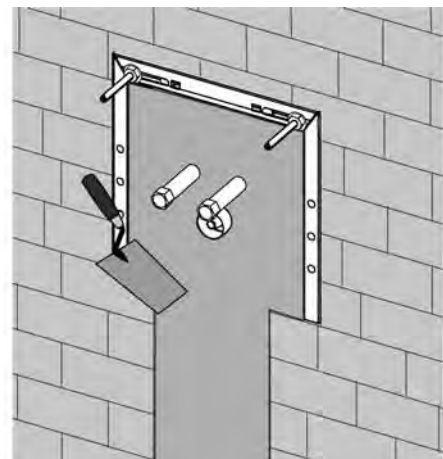

The plaster is then applied and the surface can be tiled.

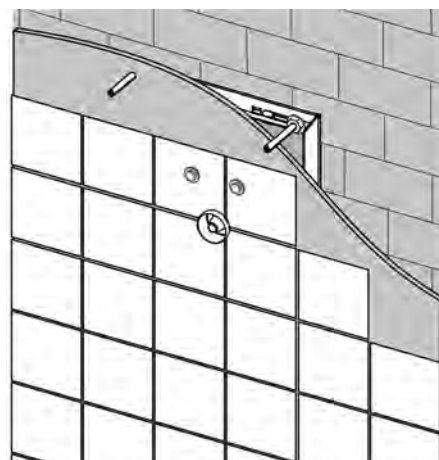

TECEbox urinal flush valve housing

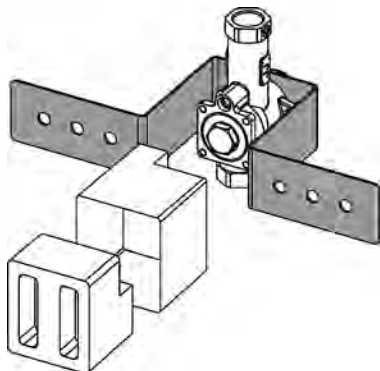

The flush value housing is placed in a wall recess and attached using the retaining plate. Any approved pipe system can be used for the water connection and inflow for the urinal ceramics.

The TECE flush valve housing is premounted on a retaining plate and can therefore easily be placed in a wall recess. The big advantage of the urinal flush valve housing is its full compatibility with the manual and electronic flush actuation versions. This means that the flush actuation version can even be changed during fine installation – or at any later point in time.

Note:

Prior to installation, you must know which urinal ceramics you are going to use. Use the latest connection dimensions from the ceramics manufacturer.

TECEbox urinal flush valve housing installation

During installation of the urinal flush valve, you must pay attention to the installation depths and heights of the retaining plate, housing and bare-wall protection.

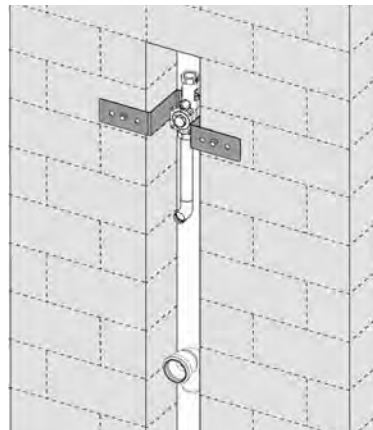
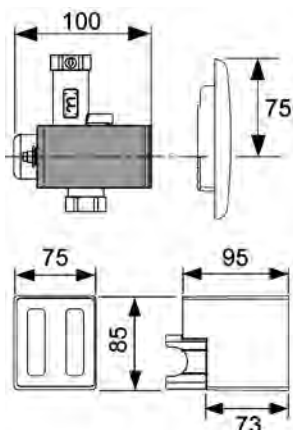
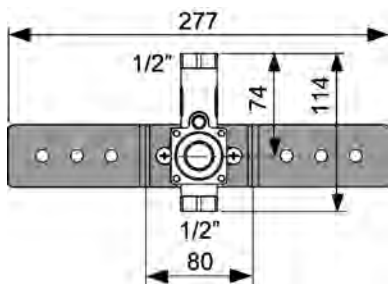

When delivered, the urinal flush valve is locked, so the required pressure test can be carried out. This inlet flow control is located above the plug. This must not be removed until fine installation.

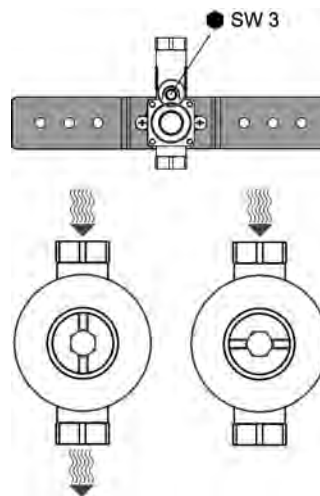

Fit the bare-wall protection and make sure it is aligned correctly.

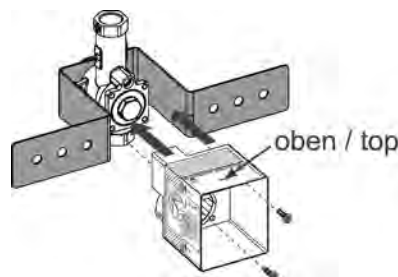

TECEbox – TECEbox urinal flush valve housing

The housing of the bare-wall protection is cut off flush to the wall after tiling. Please note the required dimensions of the wall thickness for the respective urinal push plate:

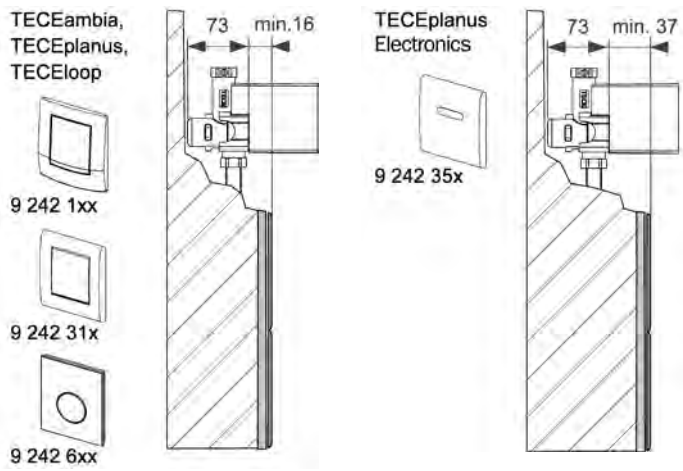

Sound insulation

Sound insulation expert opinions for toilet modules of the TECEbox series

The sound measurements of the LIN installation sound level by the Fraunhofer Institute in Stuttgart prove that TECE also meets the standard sound insulation requirements in accordance with DIN 4109 – installation sound level L_{in} 30 dB(A). The installation sound level L_{in} was calculated in the measuring space diagonally below. Measurements were taken in front of a solid installation wall with a mass relating to the area of $m = 220 \text{ kg/m}^2$. For all measurements, washdown ceramics from TOTO were used along with a sound insulation set for toilet ceramics.

Excerpt from TECEbox test report:

Installation sound level L_{in} in accordance with DIN 52 219 and DIN 4109 in dB(A)	
Stimulus	Measuring space GF back (diagonally below installation space)
TECEbox with TECE cistern order no. 9 370 000	29 dB(A)

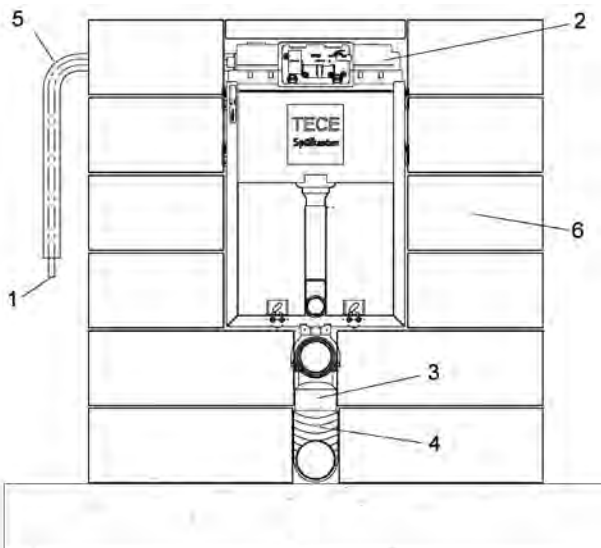

Item	Article name	Article number
Bare wall installation		
1	Composite pipe TECEflex, dim. 16	7 320 16
2	Brick-wall cistern TECEbox	9 370 000
3	HT drain pipe DN 100	
4	Adhesive felt binding	
5	Pipe insulation	
6	Aerated cement blocks	
Fine installation		
7	Washdown toilet ceramics, TOTO	
8	TECE sound insulation set for toilet	9 200 010
9	TECEambia toilet push plate	9 240 200

TECEbox parts list

Excerpt from TECEbox plus test report:

Installation sound level L_{in} in accordance with DIN 52 219 and DIN 4109 in dB(A)	
Stimulus	Measuring space GF back (diagonally below installation area)
TECEbox plus incl. assembly area cover Order no. 9 371 000 Order no. 9 200 012	28 dB(A)*

* Hollow spaces below the cistern must be filled with commercially available mineral wool on the construction site

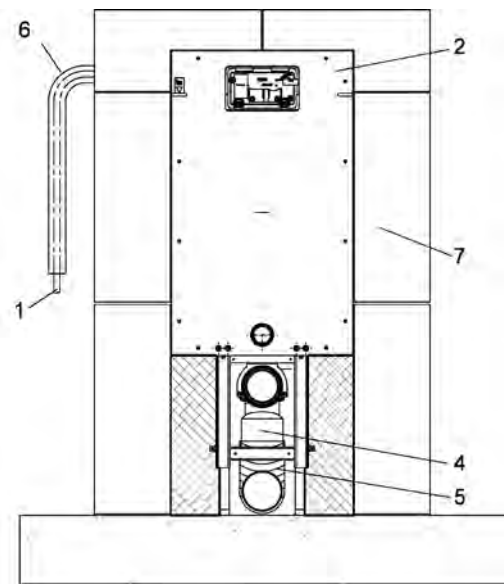

Item	Article name	Article number
Bare wall installation		
1	Composite pipe TECEflex, dim. 16	7 320 16
2	Brick-wall cistern TECEbox plus	9 370 000
3	Assembly area cover TECEbox plus	9 200 012
4	HT drain pipe DN 100	
5	Adhesive felt binding	
6	Pipe insulation	
7	Aerated concrete blocks	
Fine installation		
8	Washdown toilet ceramics, TOTO	
9	TECE sound insulation set for toilet	9 200 010
10	TECEambia toilet push plate	9 240 200

Parts list TECEbox plus





TECE Flushing Technology
Technical Guidelines



The TECE cistern	78
Tank	78
Drain valve A2	78
Drain valve A1	80
Filling valve	81
Installation	81
Toilet push plates	83
Urinal flush valve	84
Mechanical flush valve	84
Electronic flush valve	85
Installation of urinal flush valves	87
Programming the urinal infrared electronics	92
Urinal push plates	93

TECE flushing technology – the cistern

The TECE cistern

TECE's concealed cistern is a multi-purpose standard unit. The cistern can be built into dry-wall and masonry constructions using a variety of frames. The TECE cistern is always equipped with the same technology inside and is therefore compatible with all the TECE push plates. Because the cistern is universal, there is a clearly laid out range, easy stock-keeping and spare parts supply.

Properties of the cistern:

- pre-assembled and sealed
- can be combined with all TECE push plates
- single or dual-flush technology possible
- sturdy lever mechanism
- 10 litre safety tank: enough water when it is needed
- compatible with the standard spare parts available on the market
- filling valve with 3/8" standard thread
- flush volume settings for each application:
 - 4.5 and 3 litres,
 - 6 and 3 litres,
 - 7.5 and 3 litres or
 - 9 and 3 litres
- cistern tank made of impact-resistant plastic
- easy to install
- self-explanatory technology

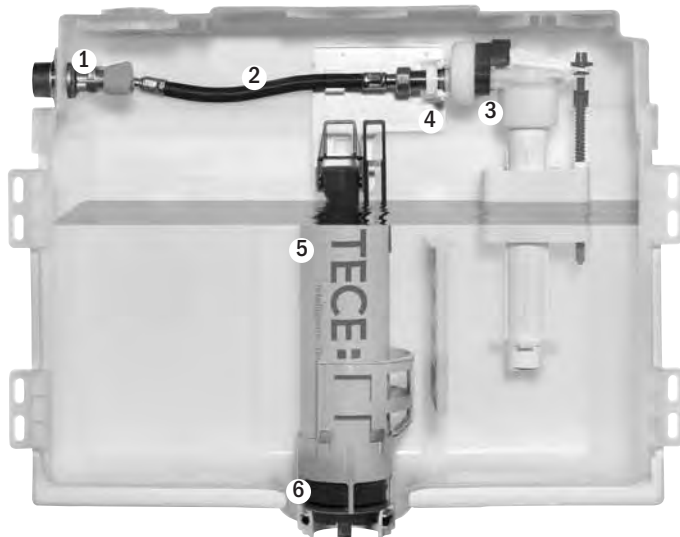

TECE cistern with

1. corner valve
2. armoured hose
3. filling valve with 3/8" standard connection
4. filling valve bracket
5. drain valve (here A2)
6. valve seat (with throttle)

Tank

Because the volume of the tank is 10 litres, there is always enough water present for flushing. Even after flushing with the large flush volume, there is always water available for a follow-up flush. The tank is made of impact-resistant plastic.

Drain valve A2

Drain valve A2 has been installed in the TECE cistern since the middle of 2009.

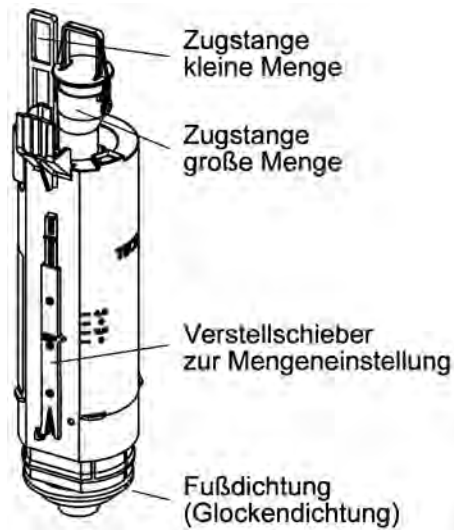

Drain valve A2, important components

Dual-flush technology

During the course of every day, a large quantity of drinking water is used for toilet flushing. The intelligent solutions from TECE make an active contribution to saving water. Using dual-flush technology, a small flush volume of 3 litres and the larger volume of 4.5/ 6/ 7.5 or 9 litres can be flushed. The factory setting for the dual-flush volume is: large flush volume = 6 litres, small flush volume = 3 litres.

Single-flush technology

A single-flush volume is also possible with the TECE cistern and the TECE drain valve. With this flush however, only the larger volume is flushed (4.5/ 6/ 7.5 or 9 litres). Using the drain valve, the flush volumes can easily be adjusted to suit the particular circumstances. In the new build sector, with matched pipes and gradients and using 4.5 litre ceramics, the 4.5 litre economy flush combined with the 3 litre flush can be used. However, pipework systems are often installed which need a larger flush volume to ensure that they work correctly. In this case, flush volumes up to 9 litres can be chosen to be sure.

Adjusting the flush volume

The flush volumes are adjusted centrally using an adjustment slide on the rear of the drain valve. The flush volumes which can be set are clearly marked on the valve.

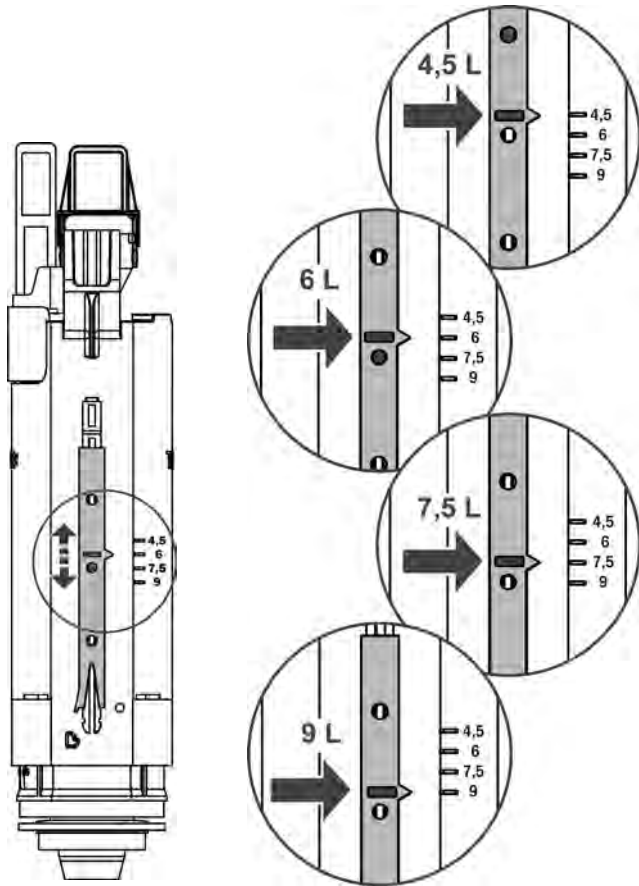

Drain valve A2, adjusting the flush volume

Throttle set

Problems with the ceramics not flushing correctly can be resolved with the aid of a throttle set.

The throttle set contains four different throttles:

- Red: 46 mm diameter (lowest throttle effect)
- Blue: 42 mm diameter (low throttle effect)
- Grey: 39 mm diameter (medium throttle effect)
- Black: 36 mm diameter (highest throttle effect)



Flush power: 110 % 100 % 90 % 80 %

Reducing the flush pressure:

If the flush pressure is too high for the ceramics, water will spray out of the ceramics. To reduce the pressure of the flush, a throttle with a smaller internal diameter can be used.

Increasing the flush pressure:

If a ceramic does not flush completely, the flush pressure of a standard cistern can also be increased after it has been installed. The flush pressure can be increased by installing a throttle with a larger internal diameter or removing the throttle which is fitted.

The flush flow throttles can be easily installed in the valve seat of the drain valve.

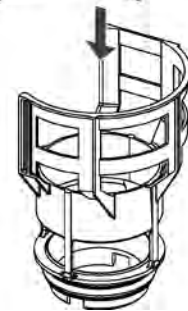
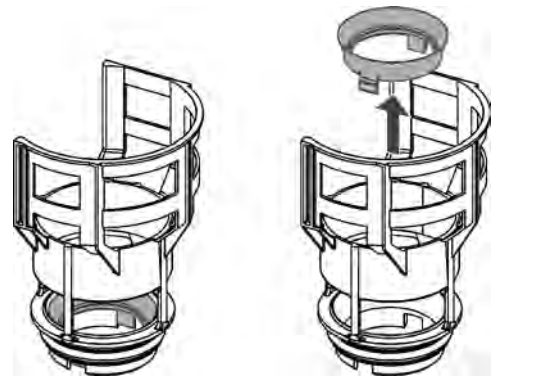

Installation and removal of the flush flow throttle in the valve seat

TECE flushing technology – the cistern

Drain valve A1

The TECE drain valve A1 was installed in the TECE cisterns up to the middle of 2009.

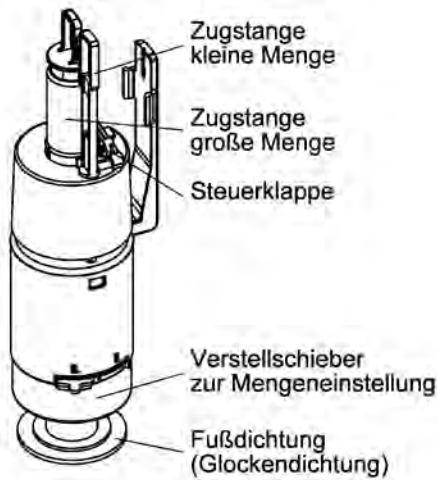

Drain valve A1, important components

Dual-flush technology

Using dual-flush technology, a small flush volume of 3 litres and the larger volume of 6 or 9 litres can be flushed. The factory setting for the dual-flush volume is: large flush volume = 6 litres, small flush volume = 3 litres.

Single-flush technology

A single-flush is also possible with the TECE cistern and the TECE drain valve. However, with the single-flush, only the large flush volume is flushed (4.5/ 6/ 7.5 or 9 litres).

Adjusting the flush volume

The flush volume setting for the large flush volume of the drain valve A1 is made using an adjustment slide in the lower area of the valve.

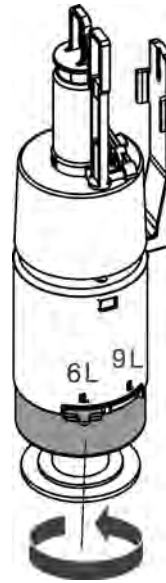

Drain valve A1, adjusting the flush volume

Conversion of drain valve A1 to the new version A2

If a drain valve is changed as a spare part or the new drain valve is modified because of the additional functions (4.5 litre flush, throttle set), then the new drain valve A2 offers full compatibility with the old version A1.

As well as the drain valve A2, the operating lever and valve seat are included in the scope of delivery.

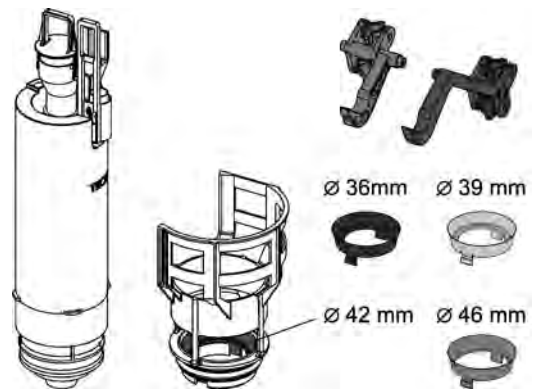

Conversion set 9 820 223, scope of delivery

The drain valve of the TECE cistern can easily be changed.

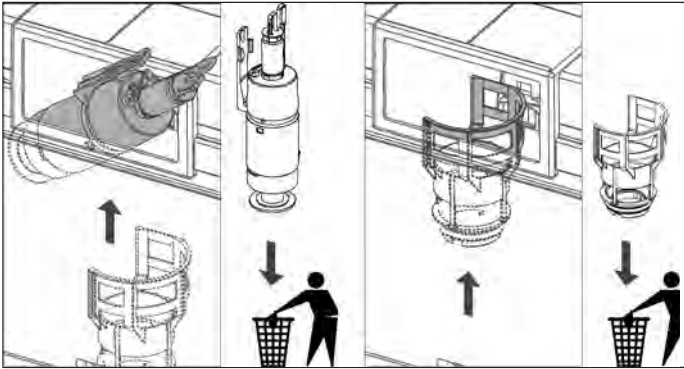

The old drain valve A1 should be disposed of, together with the associated valve seat and seal.

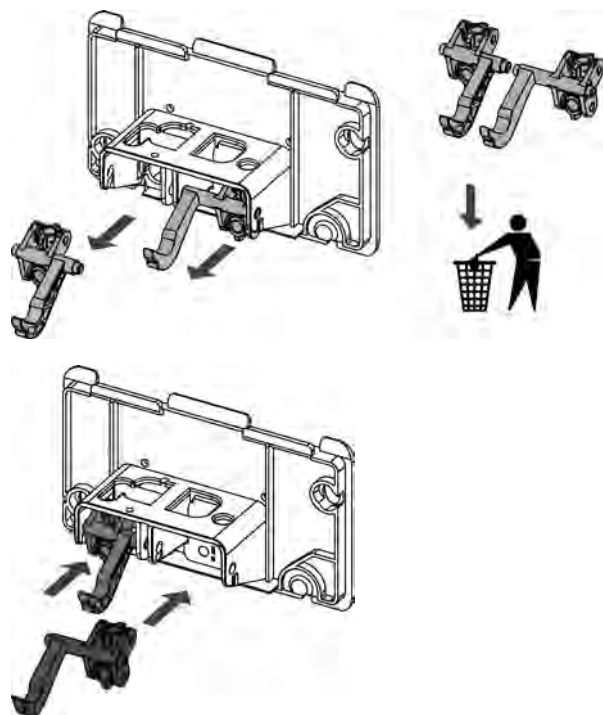

When replacing an old drain valve A1 with a new A2, care must be taken that the operating lever is also changed.

Filling valve

The proven low-noise standard filling valve of the TECE cistern is equipped with a 3/8" standard thread. Because of this interface, standard replacement valves with 3/8" thread connections are also compatible.

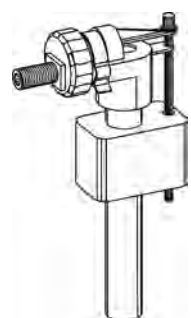

Filling valve F1

Installation

Shell construction installation

The corner valve of the TECE concealed cistern is self-contained and pre-installed as a complete unit. Pressure testing can be done without the cistern needing to be opened. Opening of the cistern is only necessary during completion work. During the shell construction stage, the cistern remains closed by a seal. An unbroken seal for the completion work guarantees that the cistern is clean and functionally sound. A damaged seal shows that the cistern has already been opened.

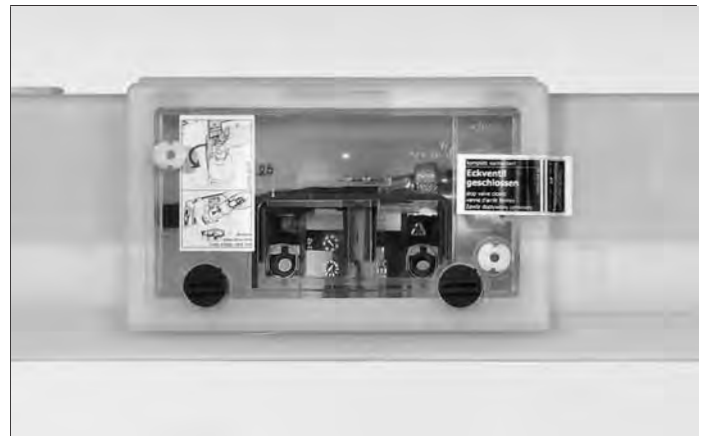

Splash protection with seal

Fine installation

The TECE concealed cistern cannot be opened without destroying the seal on the splash protection. If the seal is intact at the fine installation stage, then the inner workings of the cistern are free of contamination and are intact. The connection pipe must be well flushed out during commissioning of the concealed cistern. To do this, the hose can be lead out of the cistern towards the outside. After flushing out, the armoured hose can be screwed to the 3/8" standard connection of the filling valve without the need for any tools.



Connection of the armoured hose to the filling valve

TECE flushing technology – the cistern

A special feature of the TECE concealed cistern is the actuation block mounted on the splash protection. When the concealed cistern is opened, it is completely removed. This also works with the support frame for the push plate in position.



Splash protection with actuation block

Despite the small inspection opening, there is enough space present for working inside the cistern. The operating lever is shaped in such a way that during insertion, it finds its own way into the draw eyes of the drain valve.

Service

After removing the cover of the push plate, the complete actuation unit can be removed with the aid of a slotted screwdriver.

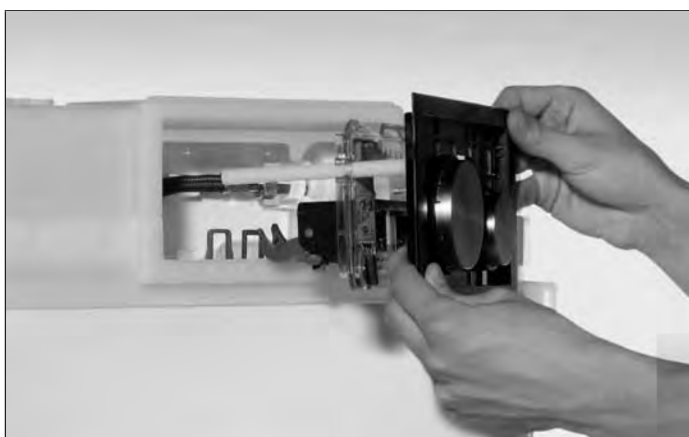

Removal of the actuation unit

This procedure is easy and saves time because removal of the individual parts is not required.

Toilet push plates

Every push plate fits all TECE cisterns! In the process, installation is possible from the front and from above. For more information on TECE push plates, please refer to the Technical Guidelines brochure "Push plates".

Overview of TECE toilet push plates



TECEbase



TECEambia



TECEplanus



TECEplanus electronics



TECEloop plastic



TECEloop glass



TECEsquare glass



TECEsquare metal



Toilet flush handle

The toilet push plates shown here depict only an overview of the product series. The complete TECE range can be found on the Internet at www.tece.com. A push plate configurator is set up there, with which you can arrange materials and colours of buttons and covers.

TECE flushing technology – urinal flush valve

Urinal flush valve

The TECE urinal flush valve is based on a further development of proven flush valve technology. Well thought out details and improved materials ensure a long life and high reliability.

The TECE urinal flush valve is suitable for mechanical and electronic actuation. The same housing is used in both cases. The flush volume can be set from one to a maximum of about eight litres.

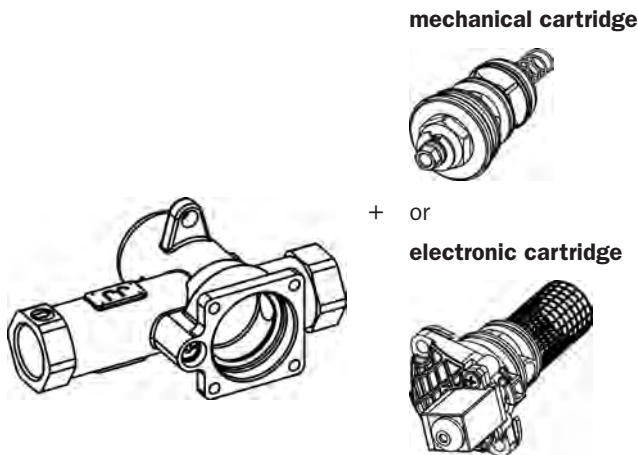

Housing for urinal flush valve and cartridges

Manual and electronic cartridges have the same flush valve housing and the same high flush performance of > 0.3 l/s at 1 bar.

The following flow diagram allows you to calculate the flush volume of the urinal flush valve depending on the supply pressure and flush time.

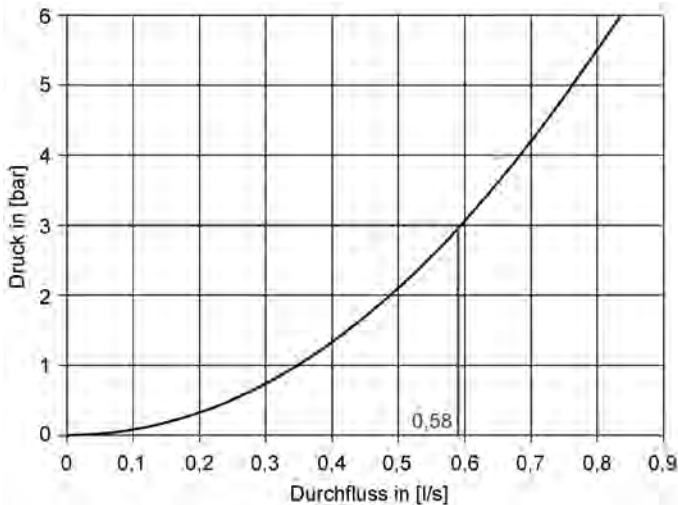

Flow diagram urinal electronics

Example:

Supply pressure 3 bar: Flush flow rate = 0.58 l/s
 Flush time e.g. 3.5 s: Flush volume approx. 2 litres

The flush housing contains the inlet flow control, this is adjusted using an Allen key (3 mm). A 90° anti-clockwise turn closes the inlet flow control, a 90° clockwise turn opens it.

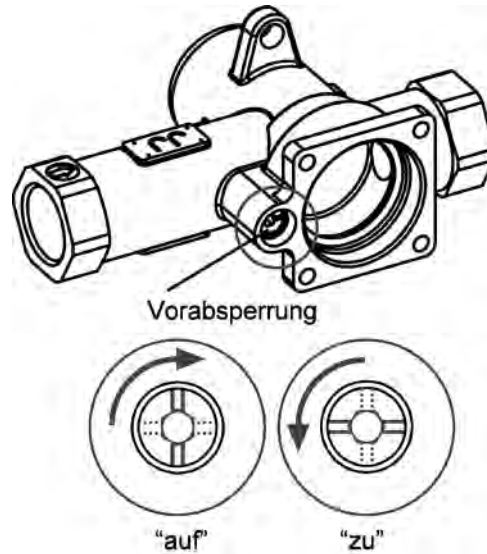

Inlet flow control

Mechanical flush valve

The mechanical flush valve (to DIN EN 12541) is hydraulically controlled and is sturdy and reliable. An automatic jet cleaning function ensures long and maintenance-free operation. The adjustable flush volume remains constant, irrespective of the supply pressure.

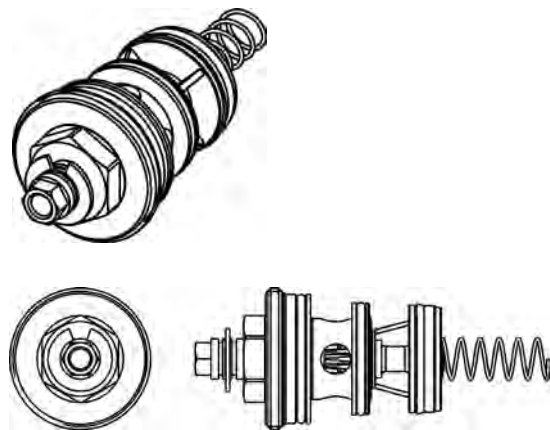

Mechanical cartridge

Volume adjustment

The flush volume of the mechanical cartridge can be set to 1, 2 or 4 litres using a retaining ring. When the retaining ring is removed, the flush valve can be set to 6 – 8 litres.

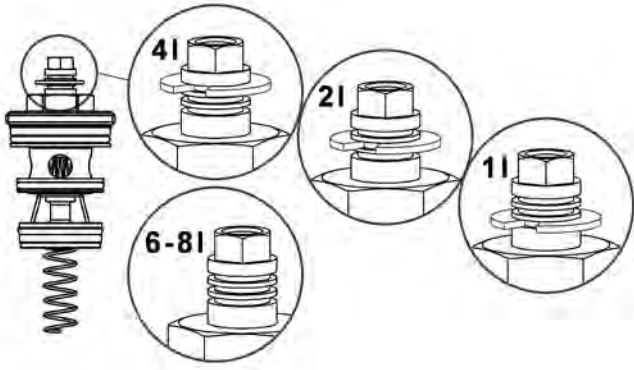

Adjusting the volume on the mechanical cartridge

All the TECE manual urinal push plates can be used together with the mechanical urinal flush valve.

Electronic flush valve

Particularly in the public sector, touch-free electronics is often required. Because the covers of the TECEplanus electronics are made of metal and are also equipped with anti-vandal protection, the electronic units from TECE are particularly well-suited for this application.

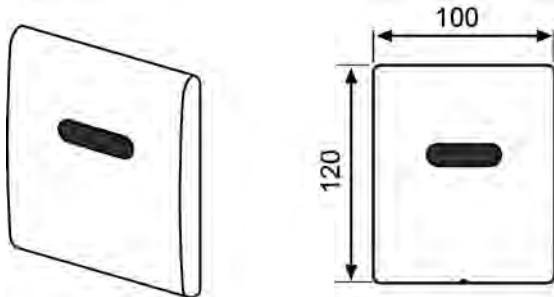

TECEplanus urinal electronic unit with infrared sensor

The infrared sensor reliably recognises every use. A magnetic key allows various settings of the electronics, including retrospectively.

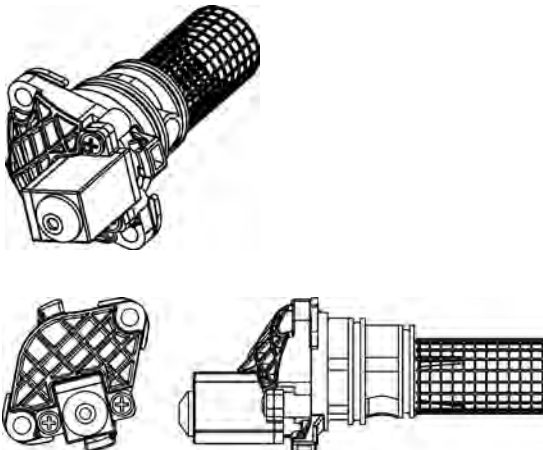

Electronic cartridge

There are two different ways in which the TECEplanus infrared electronics can be supplied with electricity:

- 6 V battery
- 230 V / 12 V mains power supply

6 V battery variant

The electronics of the battery variant has a connection to a battery (connector with white marking) and one to an electronic cartridge (connector with black marking).

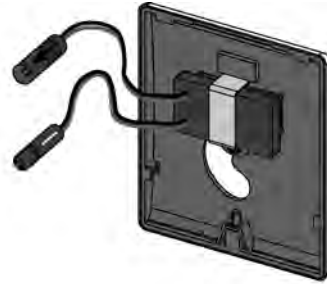

Urinal electronics, 6 V battery version

The power is supplied by one 6 V battery, type: 2 CR 5 Lithium 6 V.

The battery endurance – based on an operating life of two years is

- 220,000 flushes or
- approx. 300 flushes/day.

When the voltage drops to 5.4 V, the voltage for operating the electronics is no longer sufficient and the battery must be changed. The electronics notifies of this by a beeping during the flush. If the voltage drops further, then a flush can no longer be performed and the electronics beeps only as soon as a person is in the reception area.

Technical data urinal infrared electronics, 6 V battery

Minimum flow pressure	0.5 bar
Max. operating pressure	12 bar
Throughput at 3 bar	0.58 l/s
Operating voltage	6 V DC
Power consumption	1 W
Max. power consumption	5 W

TECE flushing technology – urinal flush valve

Battery type	Lithium 6 V, 2 CR 5
Operating life, battery	approx. 3 years max.
Protection class	III
	Safety extra-low voltage (SELV)
Flush time, factory setting	3 s
Flush time, adjustment range	2–10 s
Preflush, factory setting	off
Preflush, adjustment range	0.5–2 s
Pause function, factory setting	off
Hygiene flush, factory setting	off
Hygiene flush, adjustment range	off, 24 h, 255 h

230 V/12 V mains version

The power supply of the mains version is via a transformer which converts 230 V AC to 12 V DC (Order No. 9 810 003, please order separately).

The electronics has a connection for the cable to the transformer (connector with white marking) and one to the electronic cartridge (connector with black marking).

The third cable is to earth the electronics onto the brass housing of the flush valve.

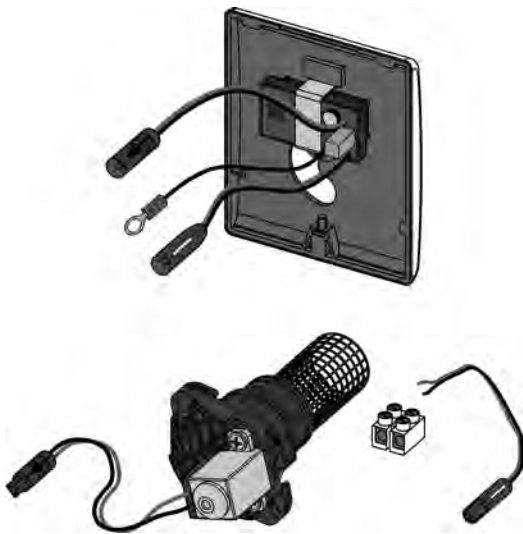

Urinal electronics, 230 V / 12 V mains version

Up to five urinal electronic units can be powered at the same time by the transformer. This is why the transformer is not (!) placed in the bare-wall protection system of the flush valve. The transformer fits conveniently in a standard flush-mounted installation box.

For installations which are in a row, the electronics must be connected in parallel and the connection cable between the transformer and the furthest electronic unit can be a maximum of 10 m long.

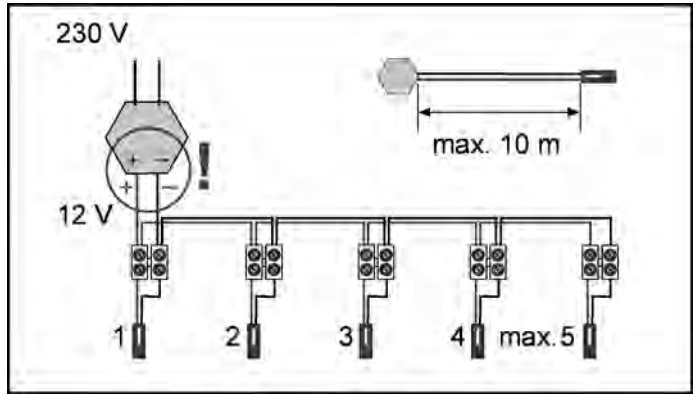

Installation of 5 urinal electronic units in a row, schematic diagram

It is recommended that only TECE original products are used for the installation. Make sure that the polarity is correct when connecting the cables.

Technical data urinal infrared electronics, 230 V/12 V mains

Minimum flow pressure	0.5 bar
Max. operating pressure	12 bar
Throughput at 3 bar	0.58 l/s
Mains voltage	230 V
Operating voltage	12 V (± 20 %)
Power consumption	1 W
Max. power consumption	5 W
Protection class	III
	Safety extra-low voltage (SELV)
Flush time, factory setting	3 s
Flush time, adjustment range	2–10 s
Preflush, factory setting	off
Preflush, adjustment range	0.5–2 s
Pause function, factory setting	off
Hygiene flush, factory setting	off
Hygiene flush, adjustment range	off, 24 h, 255 h

Technical data 230 V/12 V mains transformer

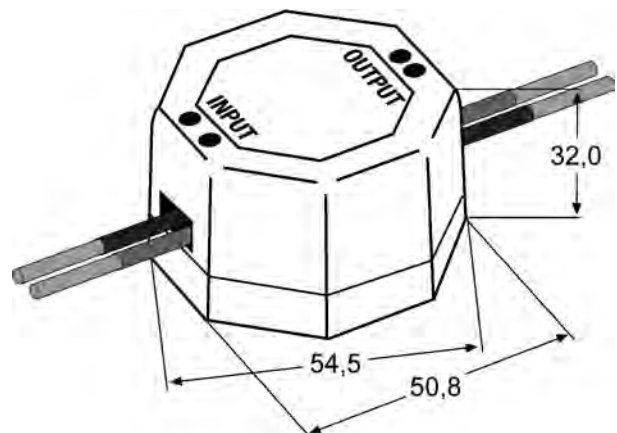

Input voltage	230 V AC (± 20 %)
Frequency	48–63 Hz
Output nominal voltage	12 V DC (± 20 %)
Output voltage tolerance	± 3 %
Residual ripple	< 50 mVpp
Output Nominal current	1.0 A
Nominal power	6 W
Minimum load	0
Efficiency factor	75 %
Overload protection	electronic
Short-circuit protection	electronic
Degree of protection	IP 20
Protection class	II
	CE low voltage supply

Operating temperature	- 20 °C to + 40 °C
Safety standard	EN 61 558 / EN 60 950
EMC standard	EN 55 022/B
Switching technology	
Switching frequency	100 KHz
Dielectric strength	3750 V/1 min
MTBF (MIL HDBK217)	120000 h

Installation of urinal flush valves

The installation procedures for the mechanical and the electronic flush valves are practically identical:

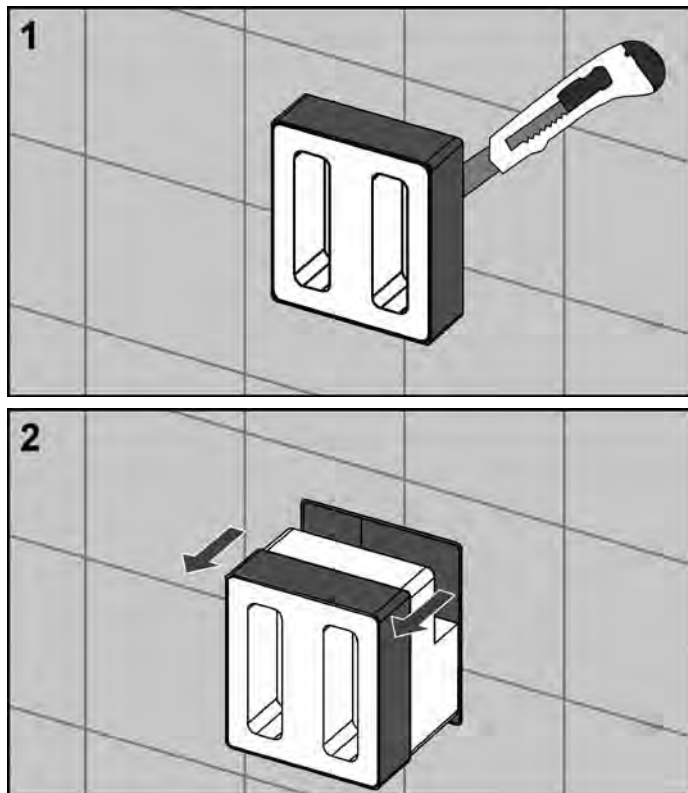

Cut away the bare-wall protection system flush to the wall and remove it together with the expanded polystyrene support.

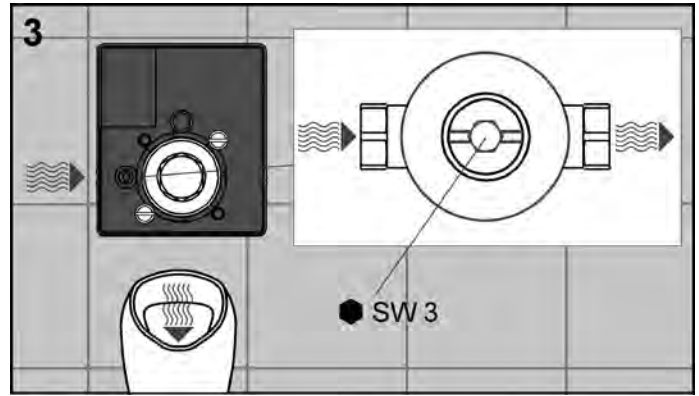

Fully flush the pipe.

Make certain without fail:

When you perform the pressure test, the inlet flow control of the flush valve must be set to open!

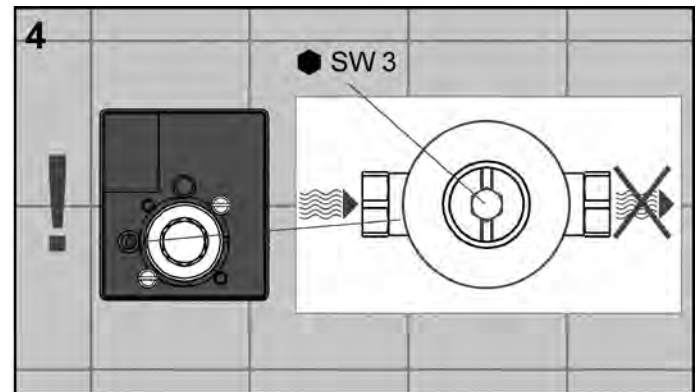

Make sure that the inlet flow control is closed before installing the cartridge, so that no water escapes during the installation. Close the shut-off using an Allen key. In the open position, (Fig. 3), the slot in the shut-off is parallel to the housing, in the closed position (Fig. 4) it is crosswise to the housing.

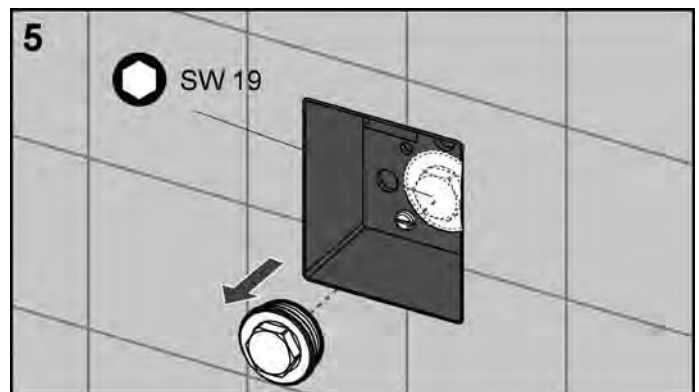

Remove the bare-wall protection plugs.

TECE flushing technology – urinal flush valve

Installation of mechanical flush valve

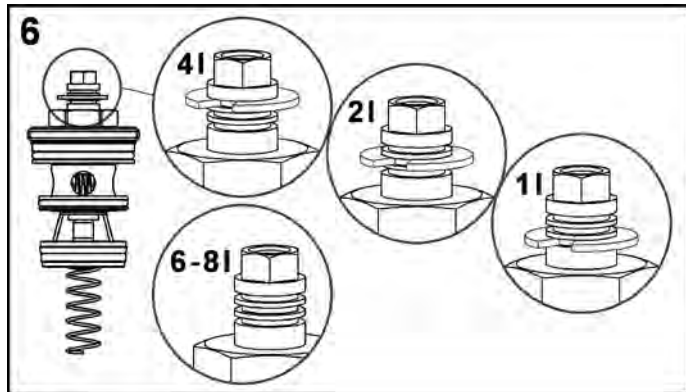

If necessary, adjust the flush volume before installing the cartridge (factory setting = 2 litres). To do this, remove the retaining ring and replace it in the appropriate groove: The first groove corresponds to a flush volume of 1 litre, the second groove 2 litres and the third groove 4 litres. Without the retaining ring the flush valve delivers 6–8 litres.

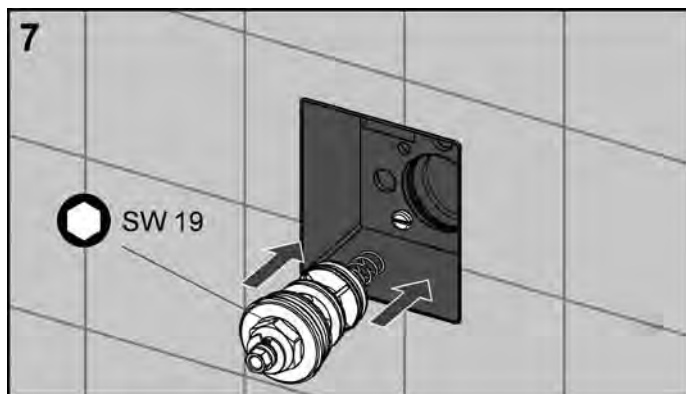

Screw the mechanical cartridge into place.

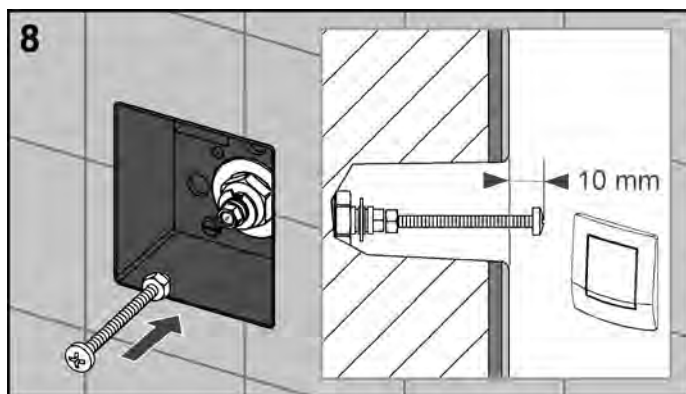

Turn in the actuation rod as far as specified (e.g. for the TECEambia 10 mm distance from the wall surface) and secure it against twisting using the lock nut.

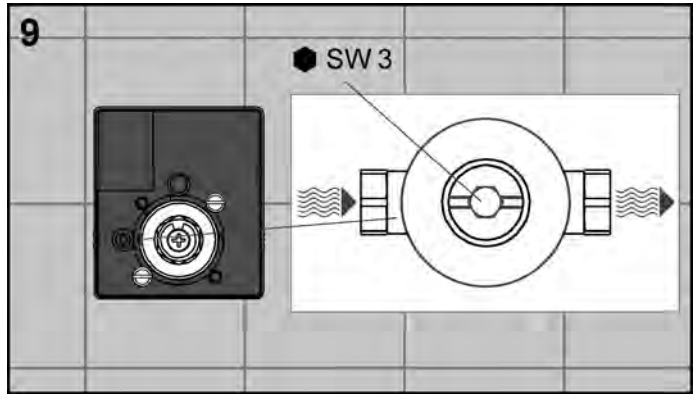

Open the inlet flow control.

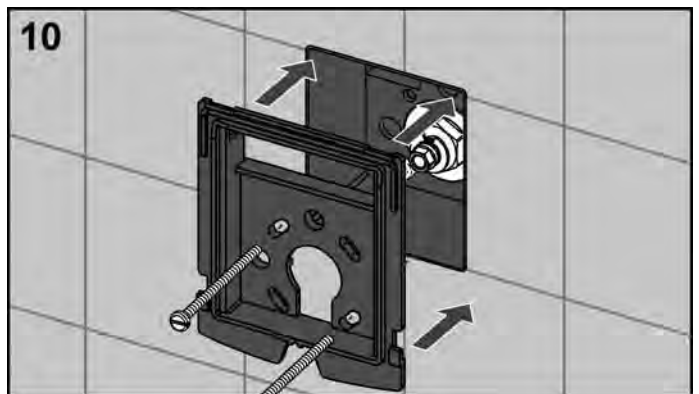

Screw the support frame onto the urinal flush valve housing.

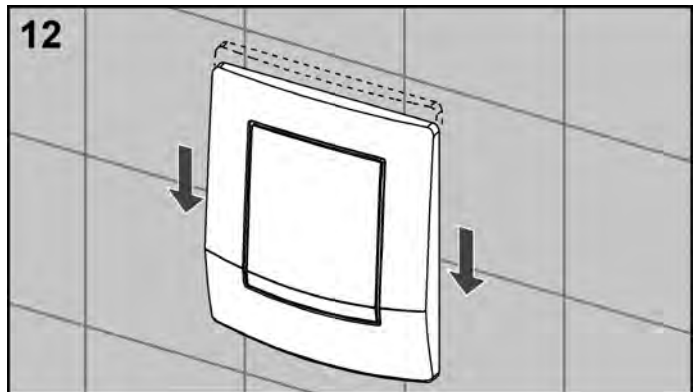
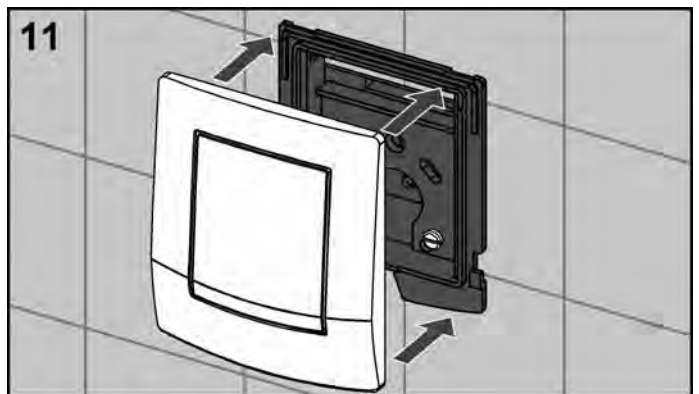

Finally install the cover of the push plate (TECEambia shown).

Installation of electronic flush valve, 6 V battery version

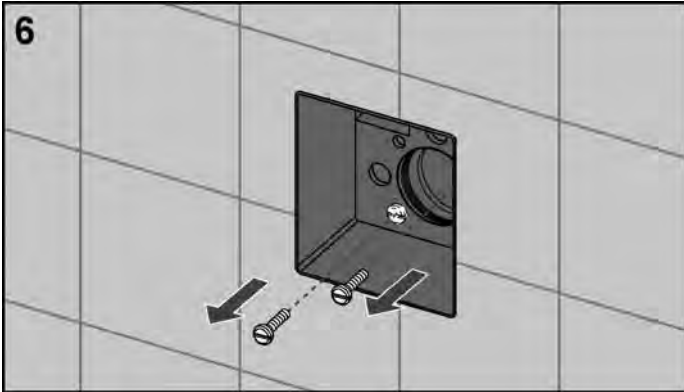

Remove the screws securing the bare-wall protection system.

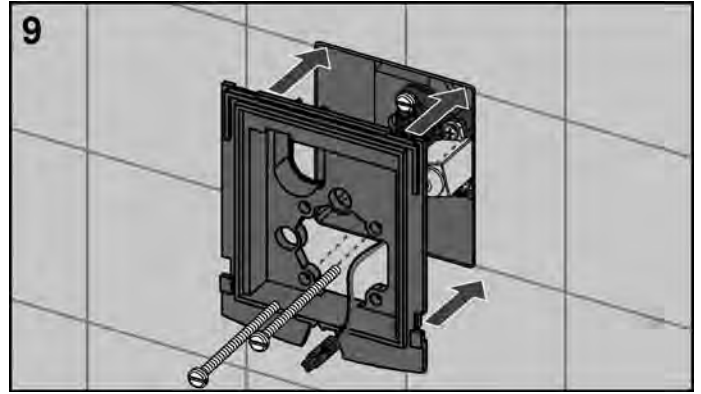

Screw the support frame onto the urinal flush valve housing.

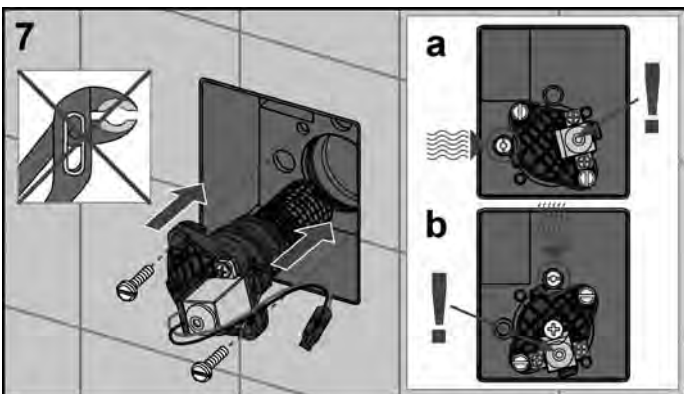

Install the electric cartridge (do not use tools to insert it!) and tighten the screws finger-tight.

Note!

It is especially important during installation of the electronic cartridge that it is in the correct position. As can be seen in the right-hand side of the illustration, the position also depends on the position in which the flush housing is installed. Housing horizontal = shut-off on left, electronics on right; housing vertical = shut-off above, electronics below. If the cartridge is installed incorrectly, it may happen that the function is correct at the start but after a certain time a fault occurs.



Plug the connection adapter onto the battery and position it in the opening provided.

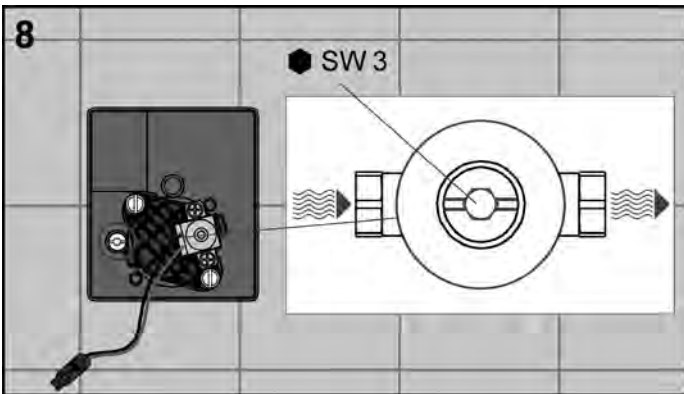

Open the inlet flow control.

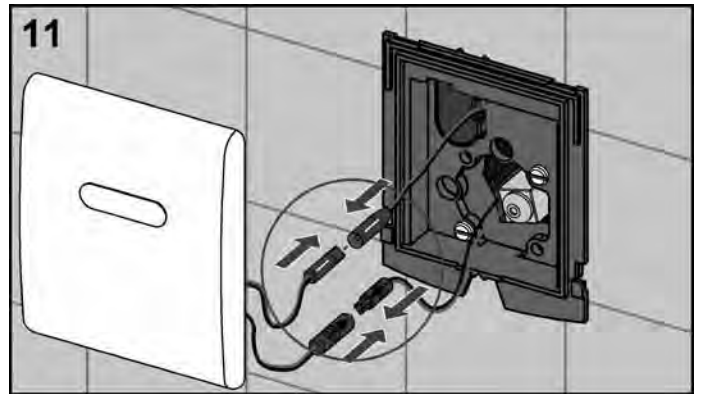

Connect the battery and the cartridge with the electronics.

TECE flushing technology – urinal flush valve

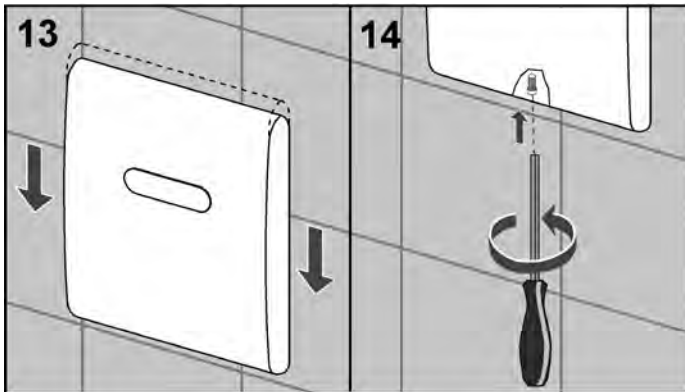
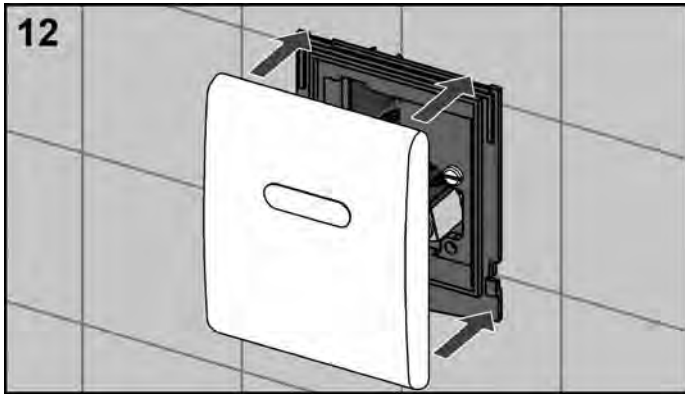

Finally install the cover of the push plate and install the supplied anti-vandal protection.

Installation of electronic flush valve, 230 V/12 V mains variant

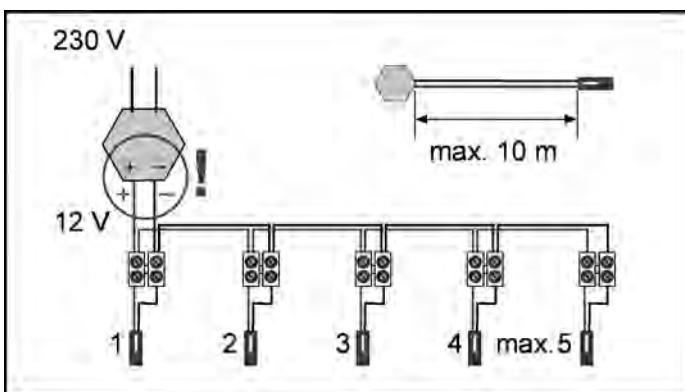
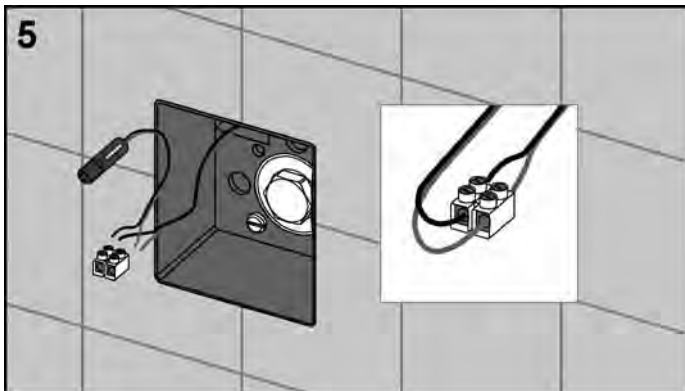

Connect the cable from the transformer to the mains connection adapter. Be careful with the polarity when making the connection!

Also take into account the maximum number (= 5) of connected electronic units and the maximum length (= 10 m) of the connection cable.

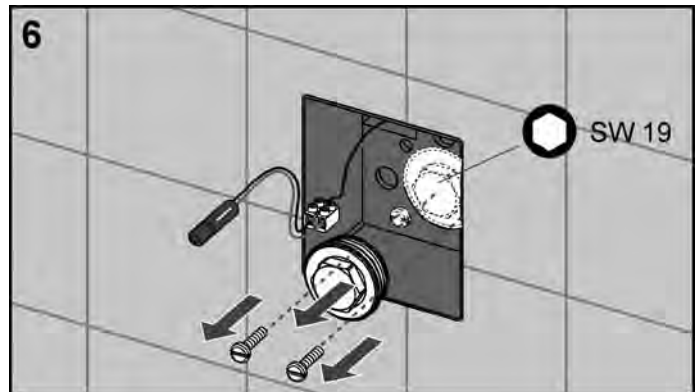

Remove the bare-wall protection plugs and unscrew the screws holding the bare-wall protection system.

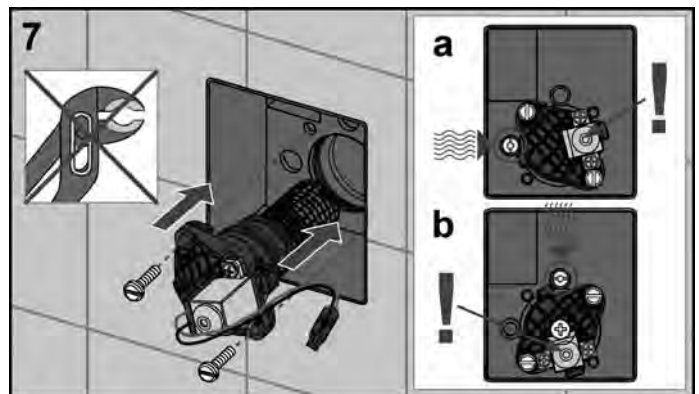

Install the electric cartridge (do not use tools to insert it!) and tighten the screws finger-tight.

Note!

It is especially important during installation of the electronic cartridge that it is in the correct position. As can be seen in the right-hand side of the illustration, the position also depends on the position in which the flush valve housing is installed: Housing horizontal = shut-off on left, electronics on right; housing vertical = shut-off above, electronics below. If the cartridge is installed incorrectly, it may happen that the function is correct at the start but after a certain time a fault occurs.

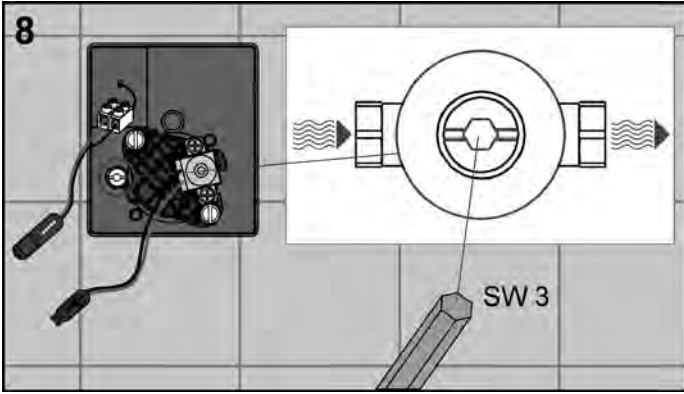

Open the inlet flow control.

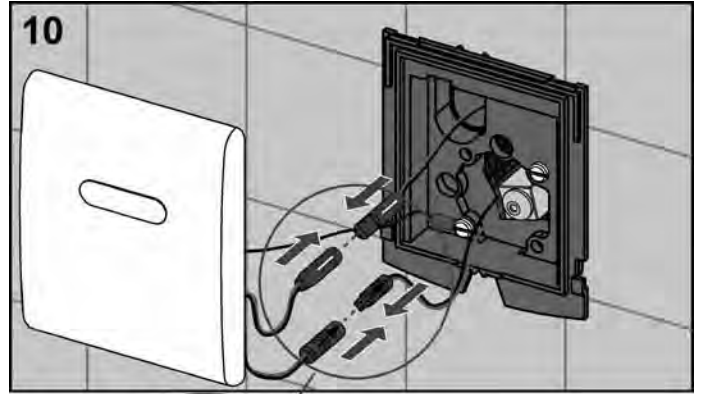

Connect the electronics to the mains and to the cartridge.

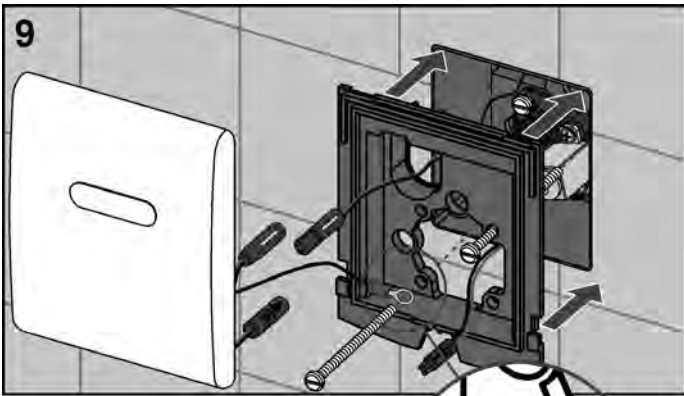

Earth the electronics via the retaining screw on the flush housing (see detail) and screw the mounting frame onto the urinal flush valve housing.

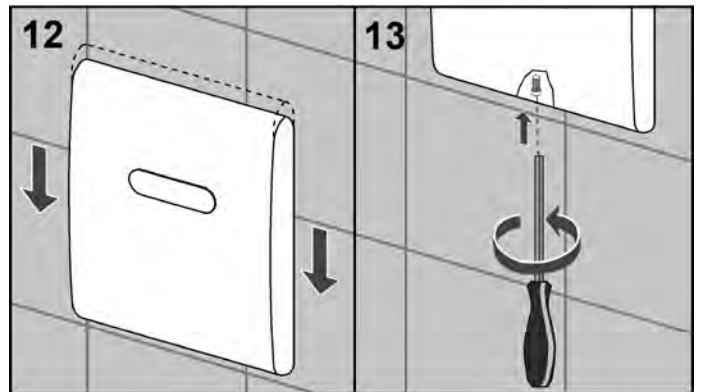
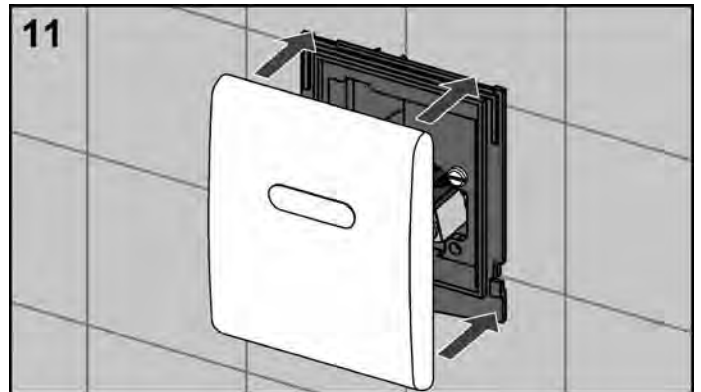

Finally install the cover of the push plate and install the supplied anti-vandal protection.

TECE flushing technology – urinal flush valve

Programming the urinal infrared electronics

Within an hour after the electrical supply has been installed, the electronics can be programmed with the aid of the magnetic key provided. If there is a further need to change the program, the power must be disconnected. Even after a power cut, the last program which was set always remains active because of a memory chip.

About five seconds after connection to the power supply, the TECE electronics remains programmable for 60 minutes. Each function which can be set is allocated a position.

Position	Function
1	Pause function off
2	Pause function on
3	Flush time 2 s
4	Flush time 2.5 s
5	Flush time 3 s
6	Flush time 3.5 s
7	Flush time 4 s
8	Flush time 5 s
9	Flush time 6 s
10	Flush time 8 s
11	Flush time 10 s
12	Preflush off
13	Preflush 0.5 s
14	Preflush 1 s
15	Preflush 2 s
16	Hygiene flush off
17	Hygiene flush 24 h
18	Hygiene flush 255 h
...	...
23	Distance 5–45 mm
24	Distance 10-40 mm
...	...
28	Factory setting

Programming list for the urinal electronics

In programming mode, the electronic system can be set using a magnetic key. In standard operating mode, this key can be used only to activate the cleaning function.

■ Cleaning function:

When the urinals are being cleaned, there is usually no need for the flush function to be triggered automatically. There has to be time for the cleaning agents to take effect. The flush function is therefore delayed by ten minutes.

■ Preflush (optional):

(Duration 0 - 2 seconds) ensures the ceramics is wetted shortly before use, to prevent the urine from adhering. A positive side effect is that the preflush stimulates the need to urinate.

■ Pause function (optional):

If the urinal is used more often than every two minutes, the water volume is automatically reduced. A cleaning flush is actuated 45 minutes after the last economy flush.

■ Variable flush time:

(Duration 2–10 seconds) the flush volume can be adjusted to suit requirements by adjusting the flush time.

■ Distance:

The state-of-the-art autofocus optical sensor functions reliably in a very wide range of building situations. Nevertheless, the optical recognition range can be altered in the case of extremely small or large urinal facilities.

■ Hygiene flush (optional):

If this function is enabled, a regular follow-up flush prevents the odour trap from drying out so that there is neither odour nuisance nor a build up of deposits (optionally 24 or 255 hours after the last flush).

■ Top up the odour trap (optional):

Today's urinals usually completely drain the odour trap and then top up with enough water to fill it again. If this does not work, the TECE electronic system's top up function can be enabled. A short flush pulse fills the odour trap again.

The TECE electronics is programmed as follows:

■ Hold the programming key in front of the sensor window.

Programming mode starts with a rapid sequence of short signal tones.

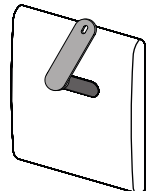

■ After the start phase, a series of identical individual signal tones can be heard. Count these until the required function is reached.

■ Now remove the programming key, after which a long confirmation tone sounds.

Example: Setting the flush time to three seconds.

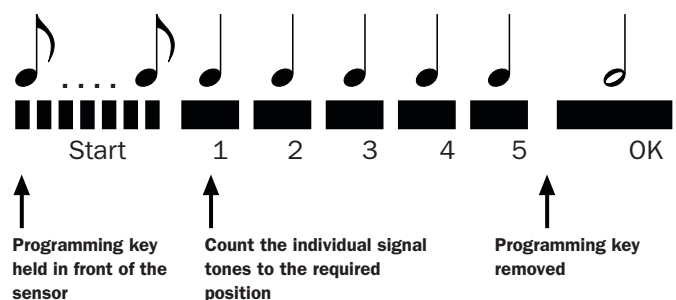

Urinal push plates



TECEambia



TECEplanus



TECEplanus electronics



TECEloop plastic



TECEloop glass



TECEsquare glass



TECEsquare metal

The urinal push plates shown here depict only a summary of the product series. The complete TECE range can be found on the Internet at www.tece.com. That overall view shows all the urinal push plates. For more information on TECE push plates, please refer to the Technical Guidelines brochure "Push plates".



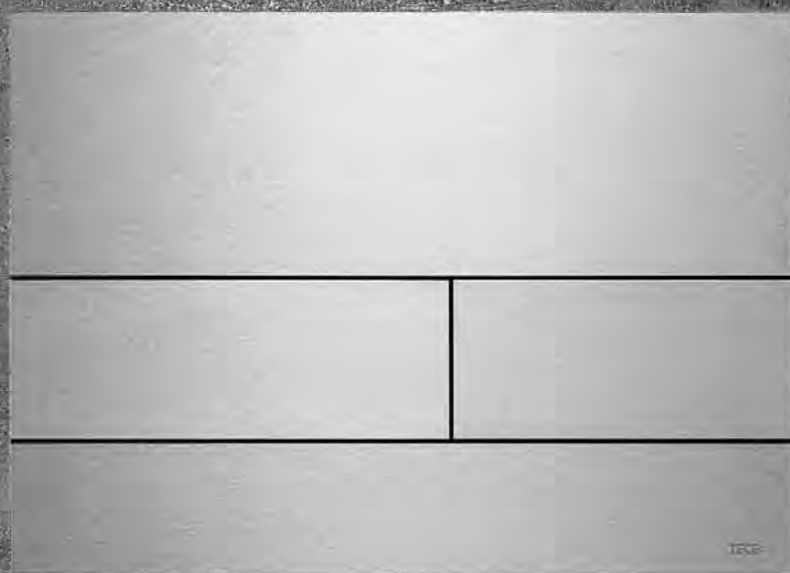

Push plates

TECE push plates Technical Guidelines

Table of contents

Overview	98
TECE push plate maintenance	99
TECEantibac	99
TECEbase	100
Toilet push plate installation	100
TECEambia	102
Toilet push plate installation	102
Urinal push plate installation	103
TECEplanus	106
Toilet push plate installation	106
Urinal push plate installation	107
TECEplanus infrared electronic device	109
TECEplanus toilet infrared electronic device	109
Installation of toilet electronic device, 6 V battery	110
Installation of toilet infrared electronic device, 12 V mains	112
TECEplanus urinal infrared electronic device	112
Urinal infrared electronic device programming	113
Technical data	114
Installation of urinal infrared electronic device, 6 V battery	116
Installation of urinal infrared electronic device, 12 V mains	118
TECEplanus electronic devices, radio actuation	121
TECEplanus remote button	121
Toilet electronic device, radio actuation, 6 V battery	123
Installation of toilet electronic device, radio actuation, 6 V battery	123
Toilet electronic device, radio actuation, 12 V mains	126
Installation of toilet electronic device, radio actuation, 12 V mains	126
TECEplanus electronic devices, cable-connected remote actuation	130
Toilet electronic device, cable-connected remote actuation, 6 V battery	130
Installation of toilet electronic device, cable-connected remote actuation, 6 V battery	130
Toilet electronic device, cable-connected remote actuation, 12 V mains	133
Installation of toilet electronic device, cable-connected remote actuation, 12 V mains	133

TECEloop	137
Installation of plastic toilet push plate, surface-mounted	137
TECEloop modular system	139
Installation of glass toilet push plate, surface-mounted	139
Installation of glass toilet push plate, flush-mounted	139
Installation of plastic urinal push plate, surface-mounted	140
Installation of glass urinal push plate, surface-mounted	141
Installation of glass urinal push plate, flush-mounted	141
TECEsquare	144
Installation of glass toilet push plate, surface-mounted	145
Installation of glass toilet push plate, flush-mounted	146
Installation of metal toilet push plate	148
Installation of glass urinal push plate, surface-mounted	148
Installation of glass urinal push plate, flush-mounted	149
Installation of metal urinal push plate	149
Flush-mounted installation	150
Dry-wall construction – toilet push plate	150
Installation of toilet push plate – dry-wall construction	150
Brick wall – toilet push plate	153
Installation of toilet push plate – brick-wall construction	153
Dry-wall construction – urinal push plate	156
Installation of urinal push plate – dry-wall construction	156
Toilet flush handle	159
Rotary mechanism installation	160
Installation dimensions for TECE push plates	162
TECEbase	162
TECEambia	163
TECEloop plastic	164
TECEloop glass	165
TECEsquare glass	166
TECEsquare metal	167
TECEplanus	168

TECE push plates – overview

Overview

TECE push plates offer a wide variety of shapes, materials and colours. With different materials, they meet the requirements of different areas of application. With a robust actuation mechanism, these push plates can be installed from the front or top. The TECE push plates are among the smallest on the market. Thanks to the special design of the cistern, the assembly space inside is easily accessible, despite the push plate's small size.

TECE push plate overview

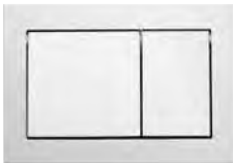

TECEbase



TECEambia



TECEplanus



TECEplanus electronic device



TECEloop plastic



TECEloop glass



TECEsquare glass



TECEsquare metal



Toilet flush handle



All TECE toilet push plates are compatible with all TECE cisterns, and all urinal push plates are compatible with all TECE urinal flush valves. Assembly is possible from the front and from the top.

Single and dual flush system

Depending on the push plate, the TECE concealed cistern offers either a single flush or the economical dual flush. During installation of a single-flush push plate, only one actuation rod is installed, with the dual flush system, two are installed.

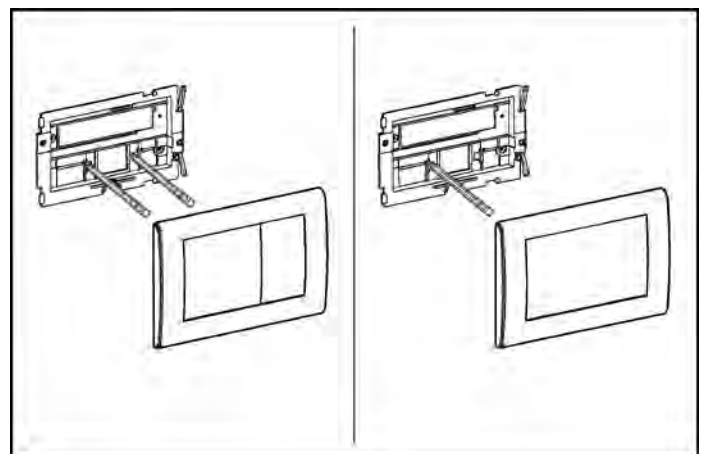

Single and dual flush system (here TECEplanus)

TECE push plate maintenance

Please be sure to note the following information to ensure that the surface of the push plate retains its appearance:

- Always clean the push plate with a soft cloth.
- Use warm water to clean the visible surfaces.
- A colourless, mild cleaning fluid can also be used to clean glass surfaces.
- The cleaning fluid must not be sprayed directly onto the glass.
- Dirt can be removed by applying slight pressure with a damp cloth.
- Do not use foaming, aggressive detergents or sponges.

TECEantibac

In the "TECEantibac" variant, the TECEambia and TECEloop push plates (toilet and urinal) have antibacterial properties. They are only available in white. Both TECEantibac push plates are available for a single or dual flush system.

What is TECEantibac?

The TECEantibac push plate is made of a new high-tech plastic containing microscopically small silver ions. These silver ions effectively prevent the spread of bacteria on the plate surface.

As the silver particles are distributed within the material, the effect continues for the plate's entire useful life. It is therefore more than just a coating. Therefore surface wear through use or cleaning do not impair the long-term effect.



**FORSCHUNGSINSTITUT
HOHENSTEIN**

The antibacterial effect of the TECEantibac push plates is confirmed in an expert report from the Hohenstein research institute: "With this test, it could be proved under practical conditions that the product TECEantibac has a significant or strong antimicrobial activity."

On average, the measured germ reduction as a result of TECEantibac was over 99.7 %. The only standardized method that exists at the moment, based on Japanese industry standard JIS 2801:2000, was applied. The method is internationally recognized and is used in Japan, America and Europe. The expert report can be provided by TECE on request.

TECE push plates – TECEbase

TECEbase

TECEbase is a simple toilet push plate made of plastic for the dual flush system. It is operated using two buttons with switching technology.

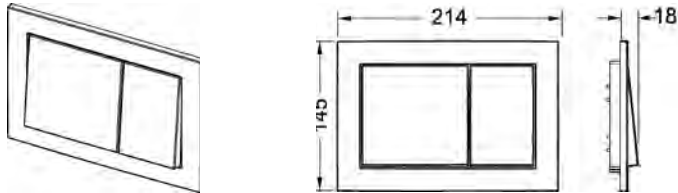

TECEbase toilet push plate, dual flush system

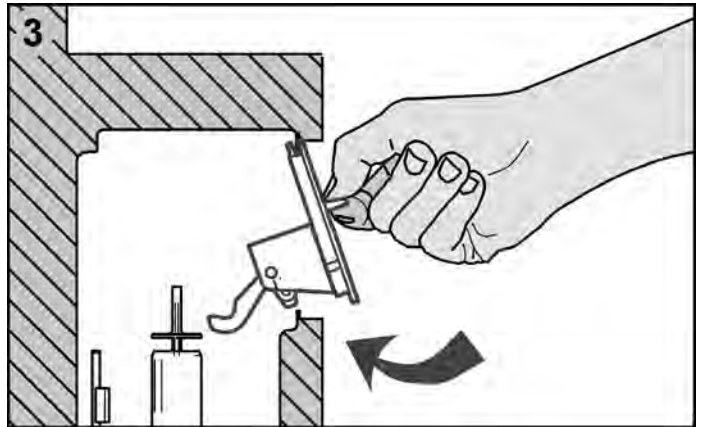

Replace the splash guard.

Toilet push plate installation

The first four steps for installation of the toilet push plate are the same for all TECE push plates:

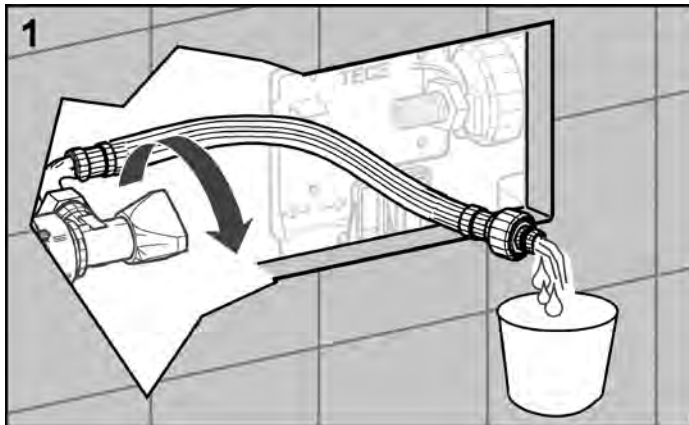

Open the corner valve and rinse out the pipe thoroughly.

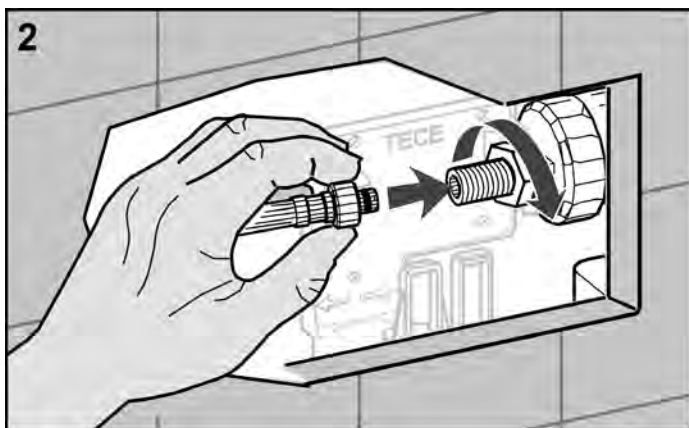

Close the corner valve again and attach the reinforced hose to the filling valve. If you want to fill the cistern with water (for initial start-up or similar), the corner valve must be open again.

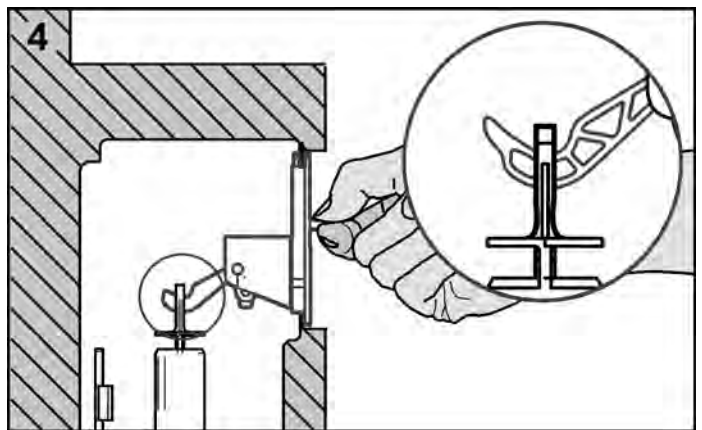

The actuation hooks must sit correctly in the lug of the drain valve. Tighten the attaching screws of the splash guard.

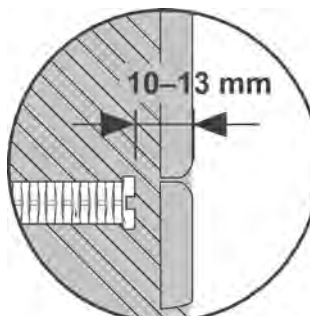
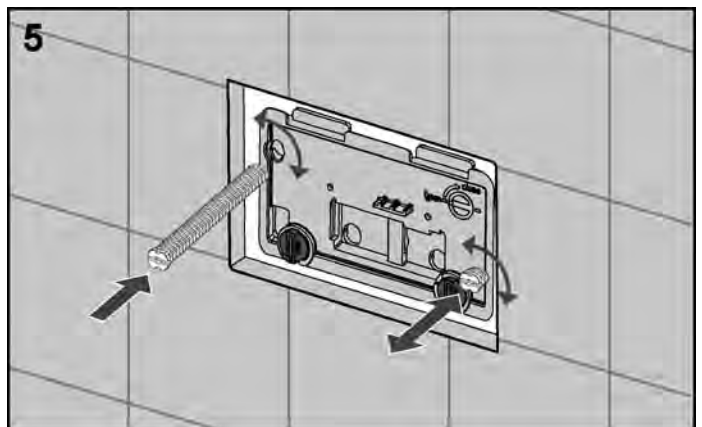

Screw in both attaching rods – distance between actuation rod and wall surface 10 to 13 mm.

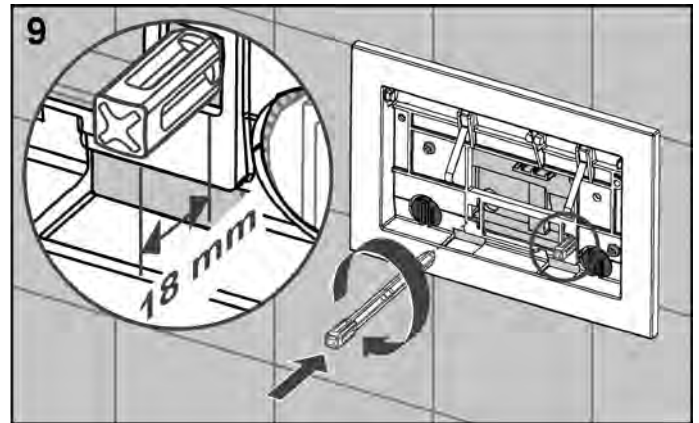
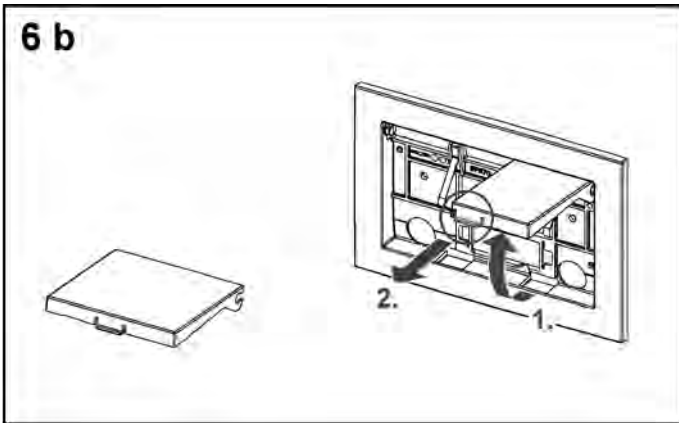
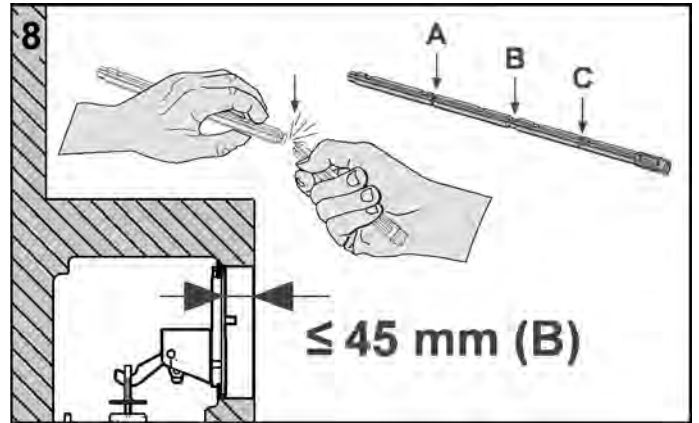
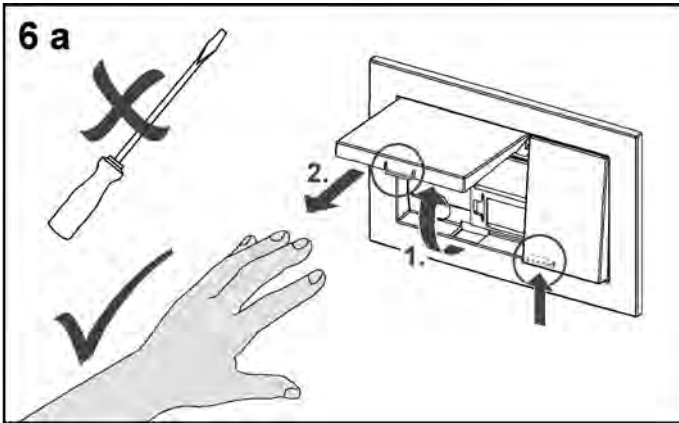

Detach both push plate buttons by hand by bending the locking hooks towards the button. To avoid damaging the buttons, do not use a screwdriver or similar tool.

Snap off the actuation rods in accordance with the wall thickness and screw them in – distance to front edge of attaching frame 18 mm.

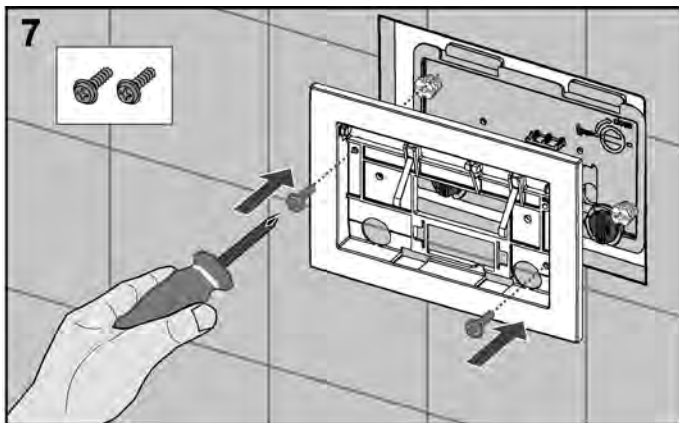

Screw the attaching frame onto the actuation rods.

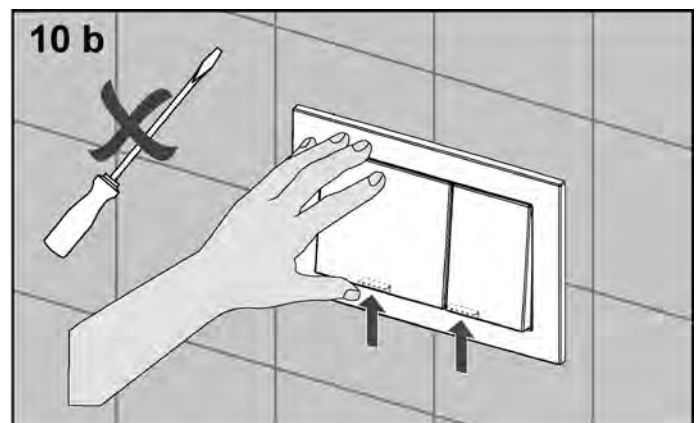
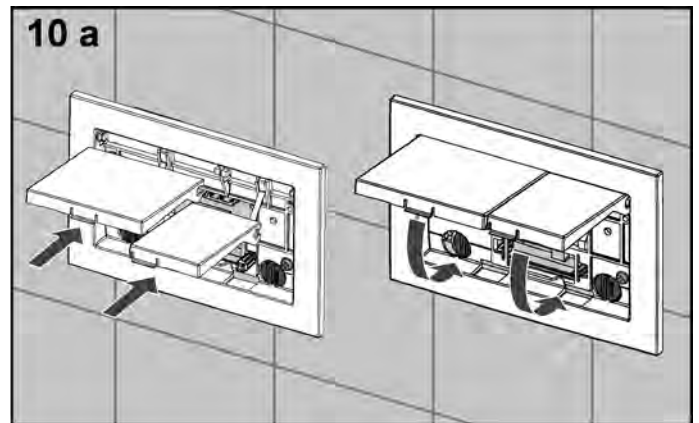

Then put the buttons back in by hand.

TECE push plates – TECEambia

TECEambia

The TECEambia toilet push plates are available for a single or dual flush system. There is also a TECEambia push plate for the urinal. The double-sided rubber buffers prevent rattling noises. The push plate is made of plastic.

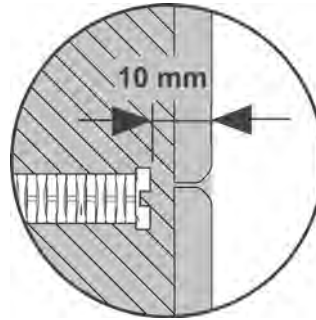

Screw in both actuation rods – distance between actuation rod and wall surface 10 mm.

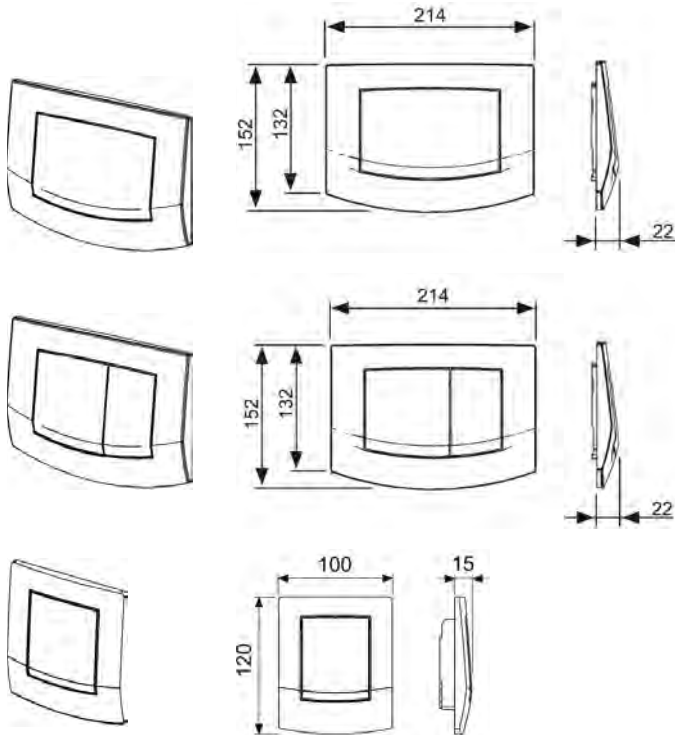

TECEambia toilet push plate, single flush system
TECEambia toilet push plate, double flush system
TECEambia urinal push plate

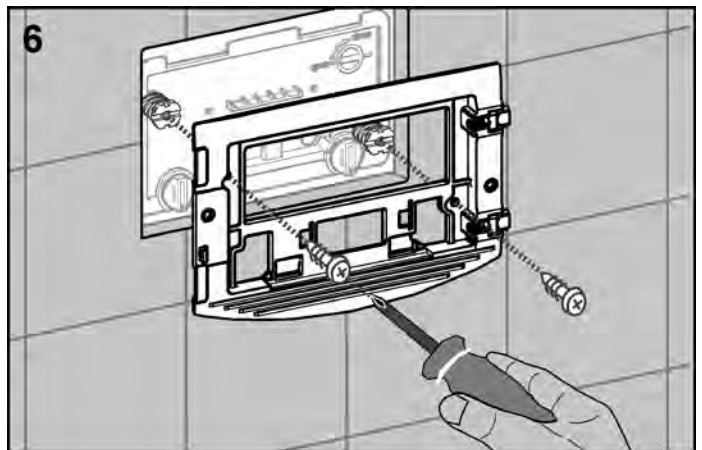

Screw the attaching frame onto the actuation rods.

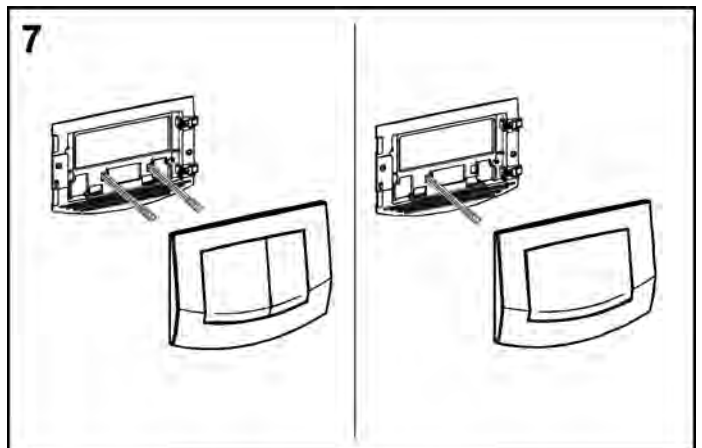

In the case of a two flush system, two actuation rods (red and blue) are installed. In a single flush system, only one is installed (blue).

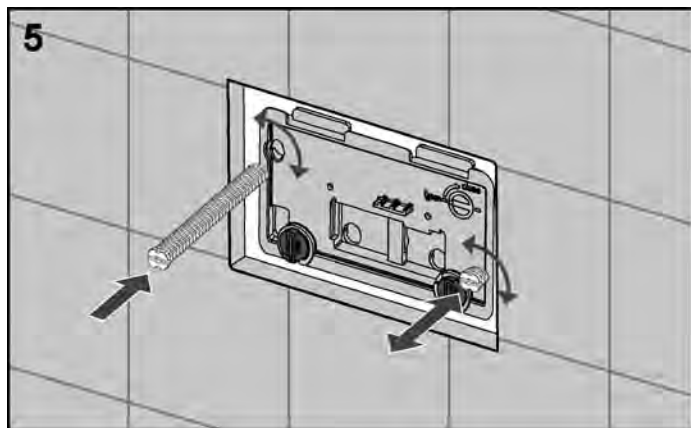

Toilet push plate installation

As with all TECE push plates the first four installation steps are the same for all toilet push plates (see section "TECEbase, toilet push plate installation").

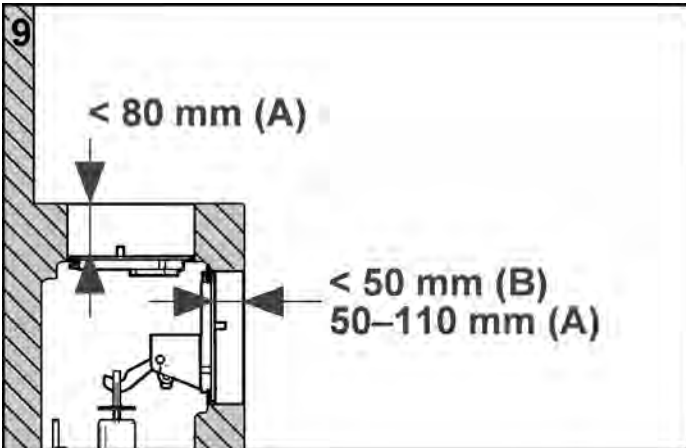
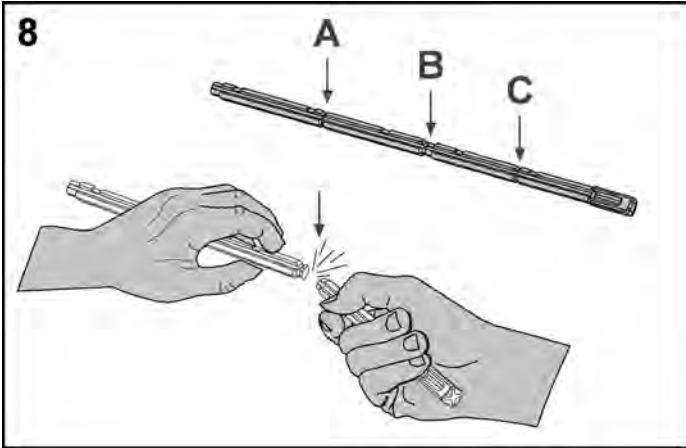

Snap off the actuation rods in accordance with the wall thickness.

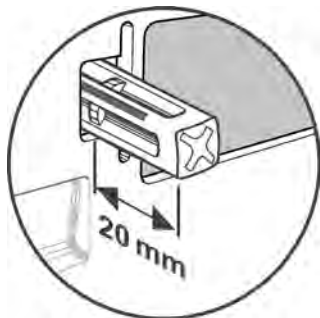
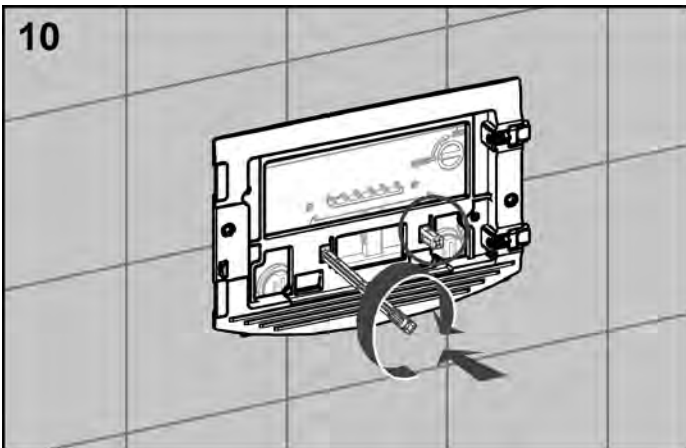

Screw the actuation rods in – distance to front edge of attaching frame 20 mm.

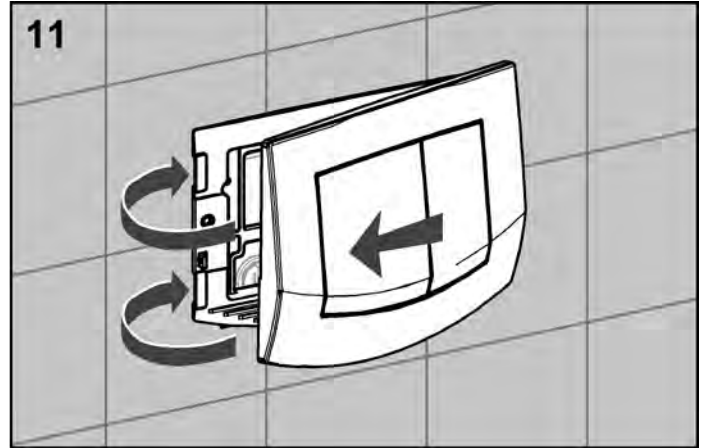

Hook in the cover of the TECEambia push plate on the right and install it by means of the catch on the attaching frame.

Urinal push plate installation

The first steps in the procedure for installing the urinal push plates are the same for all TECE urinal push plates (surface-mounted):

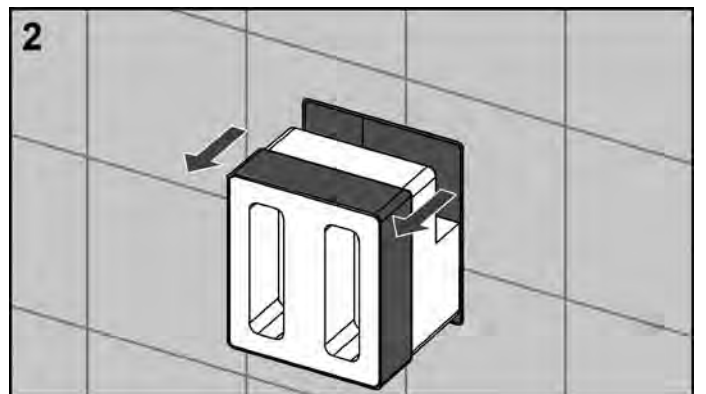
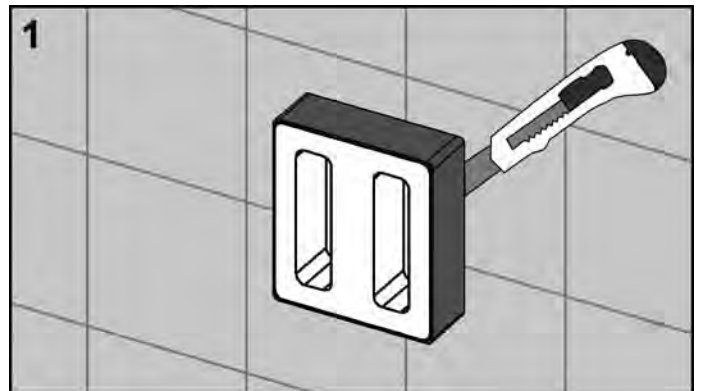

Cut off the bare-wall protection system flush to the wall and remove it together with the polystyrene support.

TECE push plates – TECEambia

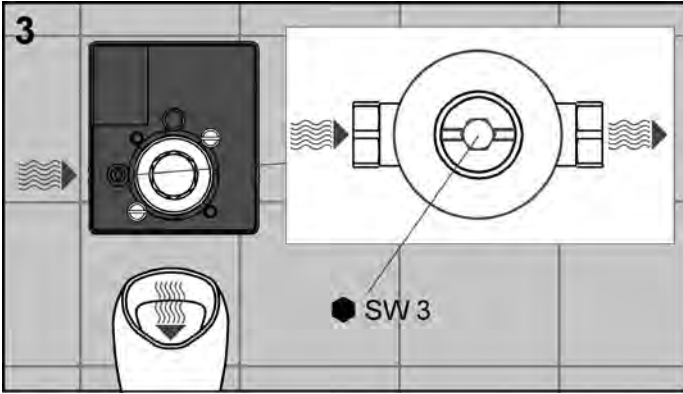

Rinse the pipe thoroughly.

NOTE:

In the pressure test, the inlet flow control of the flush valve must be set to through-flow.

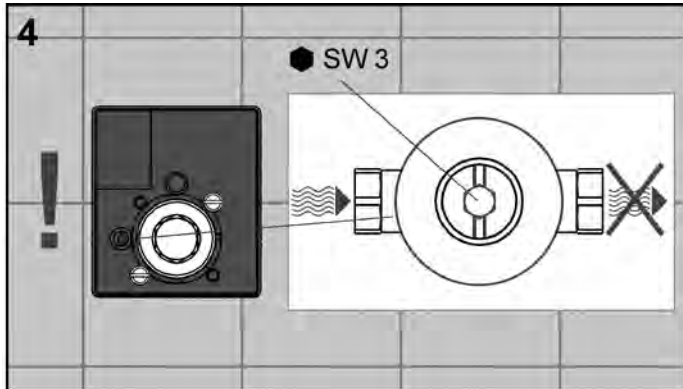

Before installing the cartridge, make sure that the inlet flow control is closed, so that no water escapes during installation. Close the flow control using a hexagonal wrench. In through-flow setting (figure 3), the groove of the flow control runs parallel to the housing, when the setting is closed (figure 4), it is at right angles to the housing.

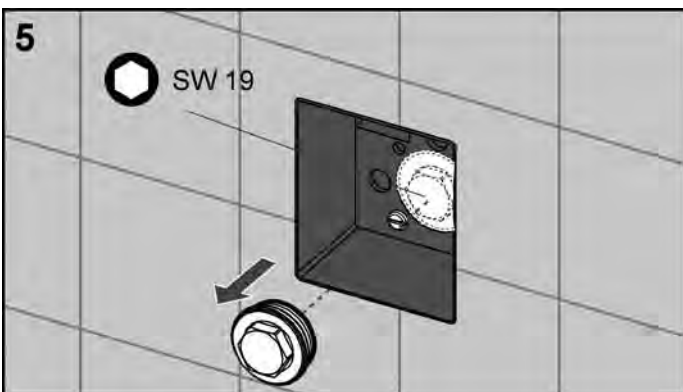

Remove the bare-wall plug.

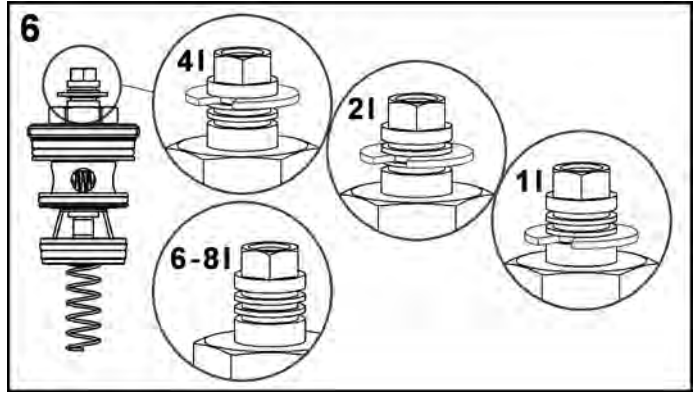

If necessary, make a flush volume setting before installing the cartridge (factory setting = 2 litres). To do this, remove the retaining ring and insert it back in the corresponding groove: The first groove corresponds to a flush volume of 1 litre, the second groove 2 litres, and the third groove 4 litres. Without a retaining ring, the flush valve flushes 6–8 litres.

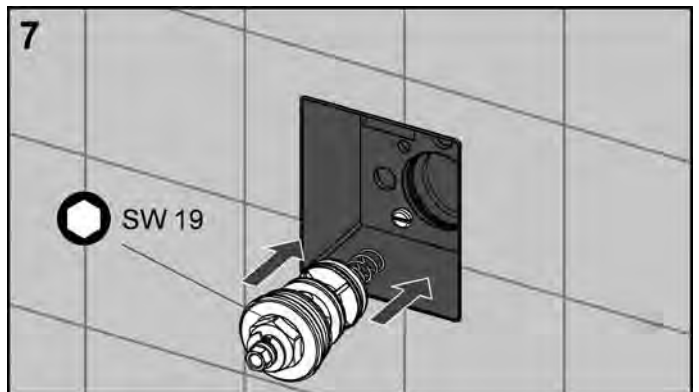

Screw in the mechanical cartridge.

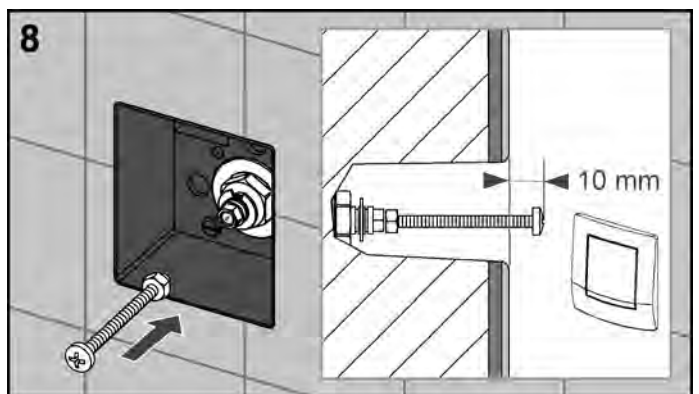

Screw the actuation rod in as far as specified (for TECEambia 10 mm distance to wall surface) and secure it against twisting with the lock nut.

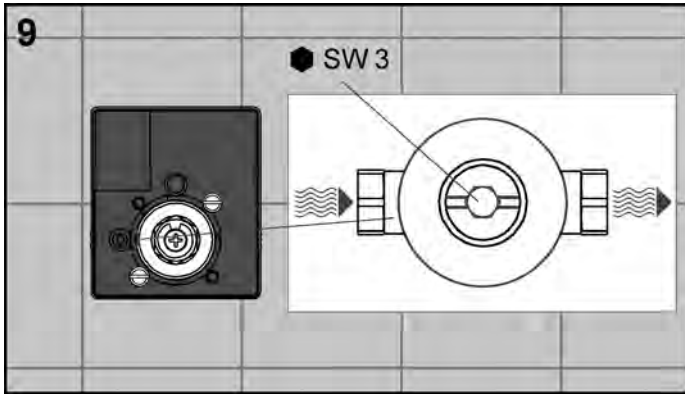

Open the inlet flow control.

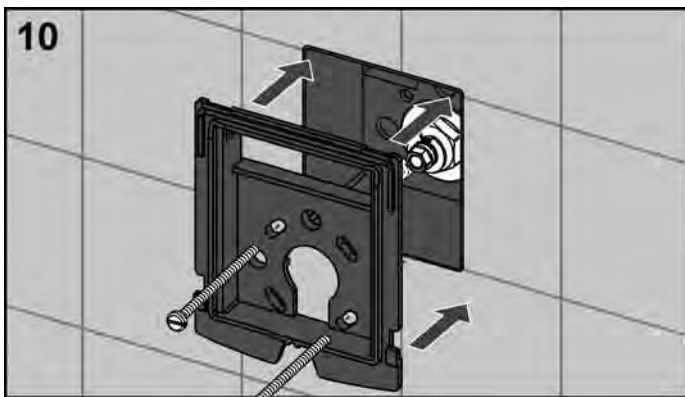

Screw the attaching frame to the urinal flush valve housing.

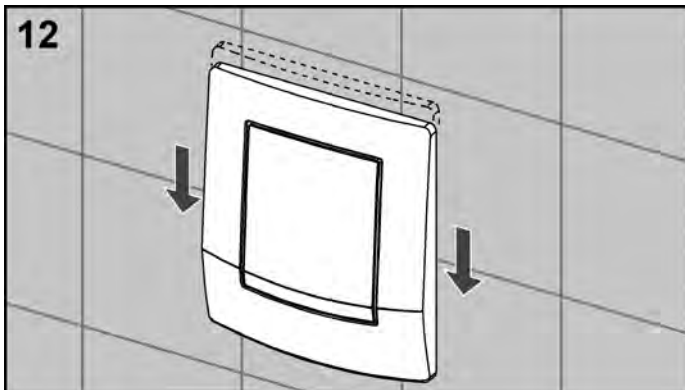
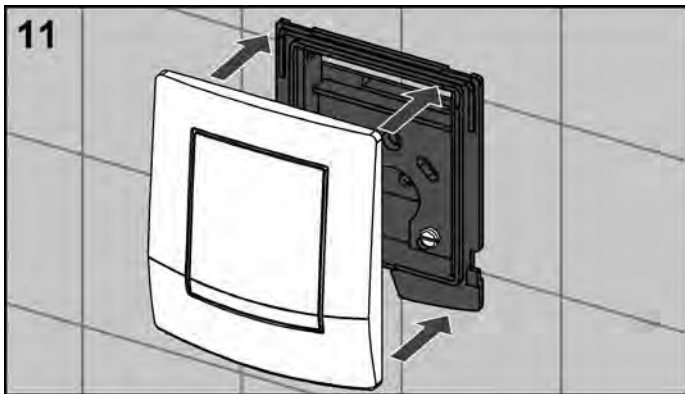

Finally, install the push plate cover.

TECE push plates – TECEplanus

TECEplanus

TECEplanus push plates are made of stainless steel and can be used in single and dual flush systems. These push plates can be made vandal-proof with a hidden screw. As a result, they are particularly suitable for public sanitary facilities, restaurants and hotels. TECEplanus push plates are also available with a matching design for urinals.

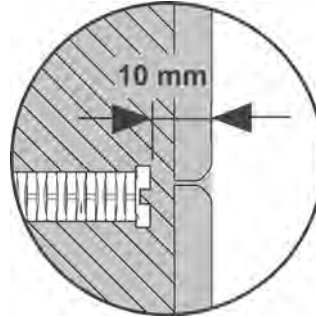

Screw in both actuation rods – distance between actuation rod and wall surface 10 mm.

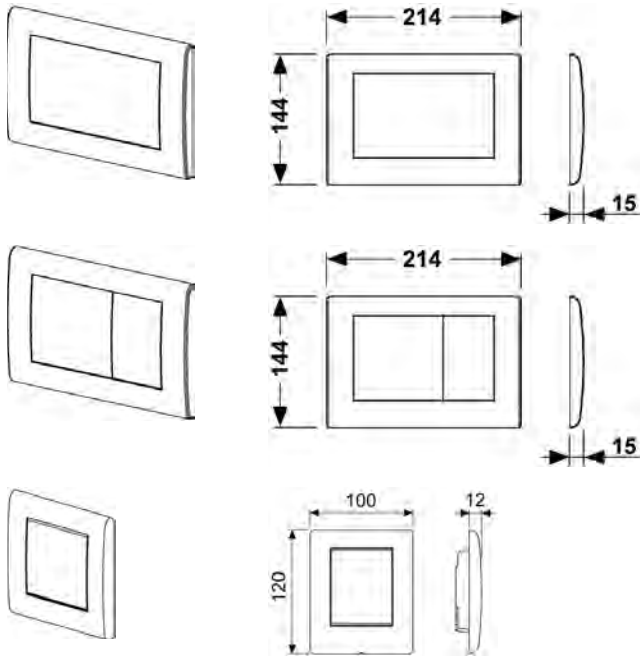

TECEplanus toilet push plate, single flush system
TECEplanus toilet push plate, dual flush system
TECEplanus urinal push plate

Toilet push plate installation

As with all TECE push plates the first four installation steps are the same for all toilet push plates (see section "TECEbase, toilet push plate installation").

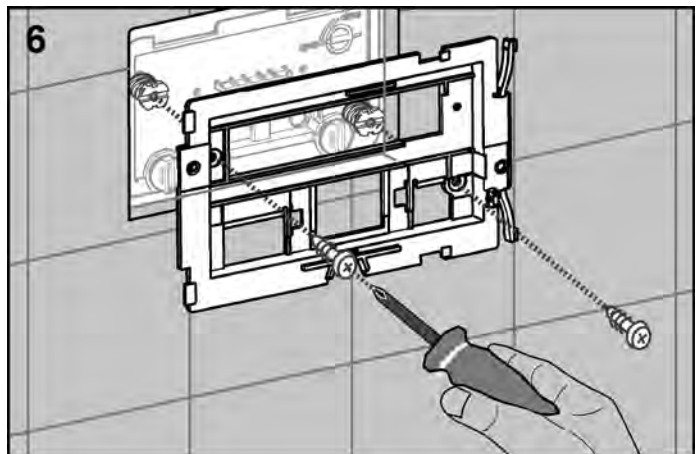
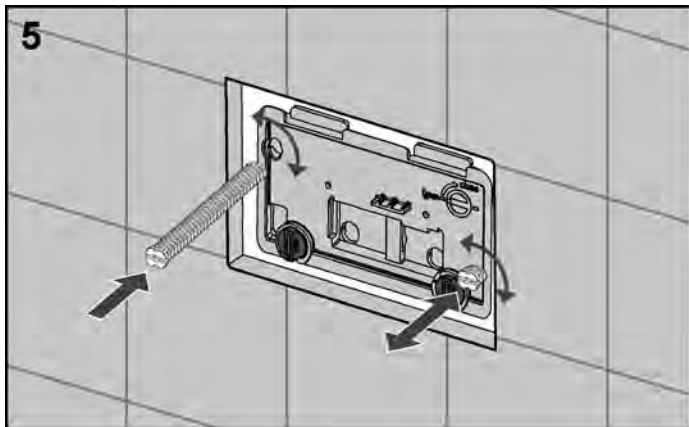

Install the attaching frame on the actuation rods.

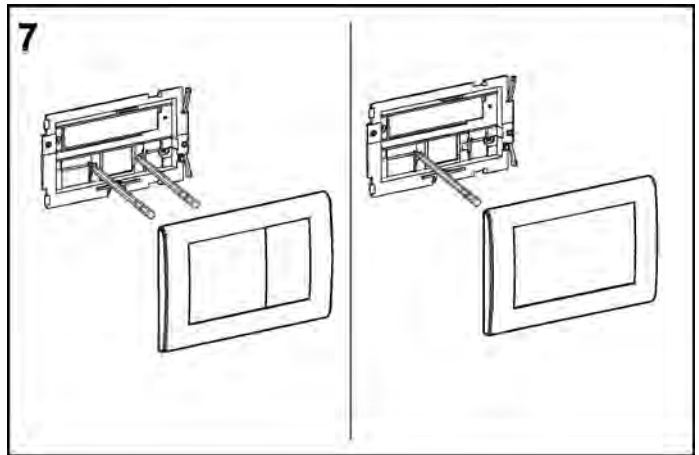

In the case of a two flush system, two actuation rods (red and blue) are installed. In a single flush system, only one is installed (blue).

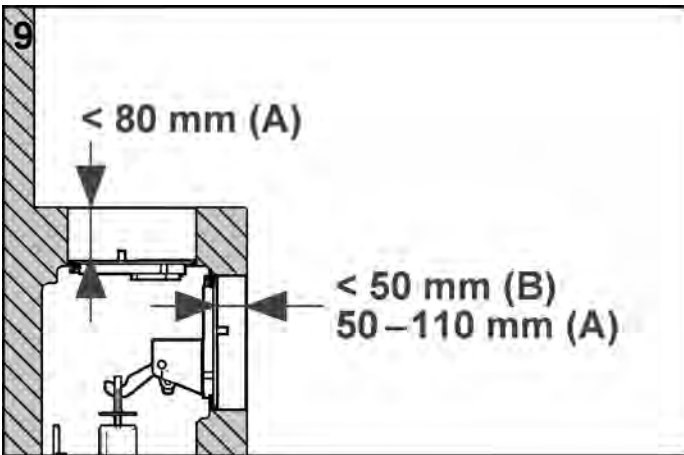
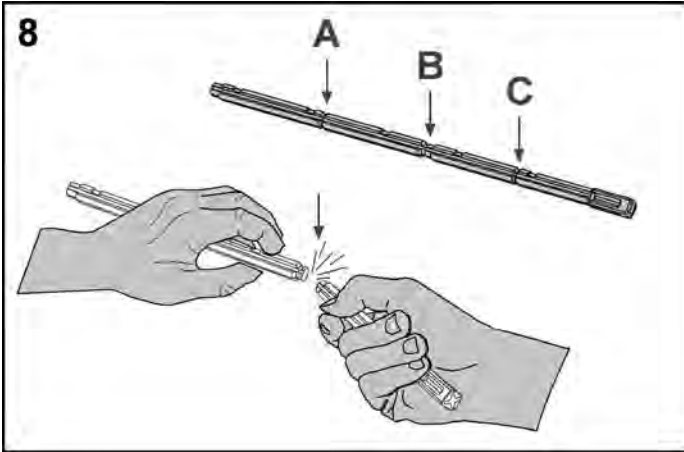

Snap off the actuation rods in accordance with the wall thickness.

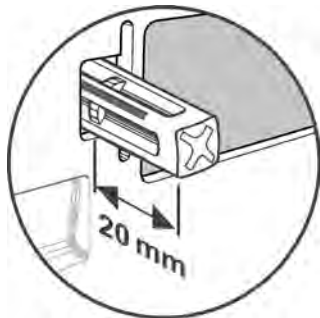
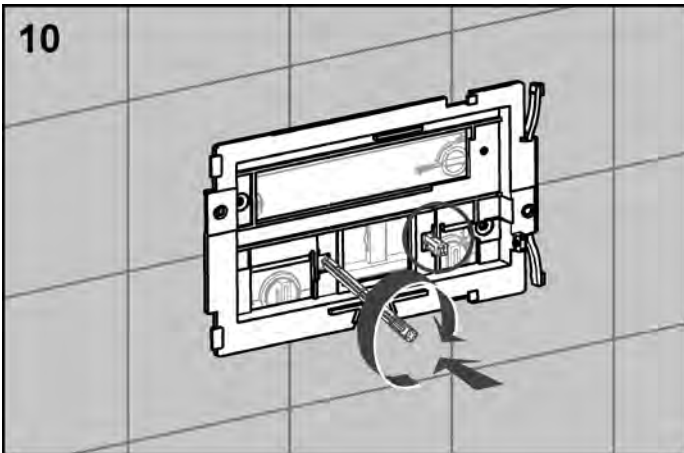

Screw both actuation rods in – distance to front edge of attaching frame 20 mm.

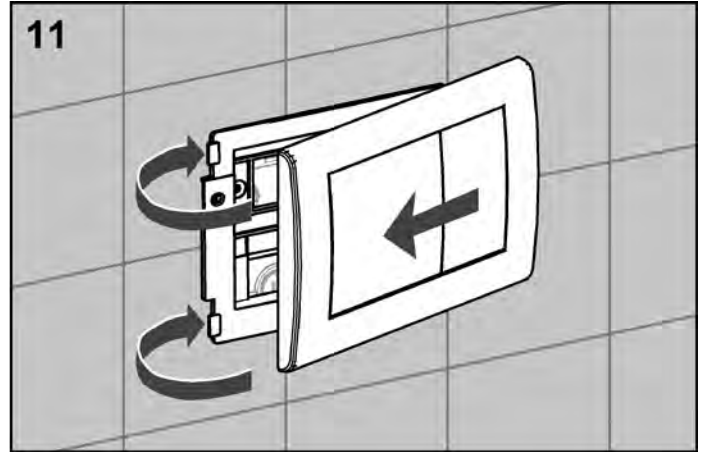

Hook in the cover of the TECEambia push plate on the right and install it by means of the catch on the attaching frame.

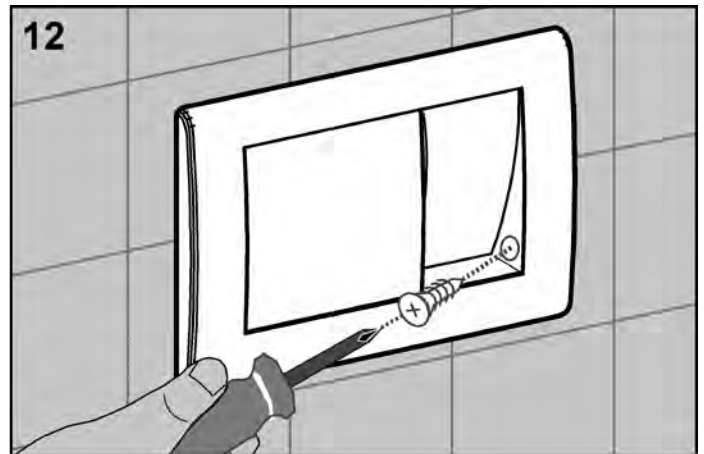

Then screw in the vandal-proofing screw into the inner side of the push plate (take care not to damage the surface).

Urinal push plate installation

The first steps in the procedure for installing the urinal push plates are the same for all TECE urinal push plates (surface-mounted) – see "TECEambia - urinal push plate installation"

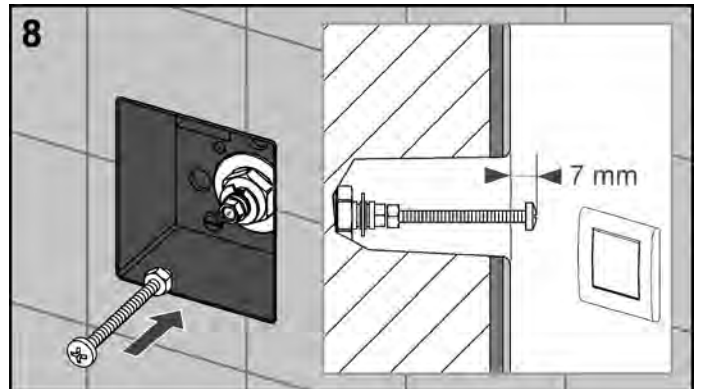

Screw the actuation rod in as specified (for TECEplanus 7 mm distance to wall surface) and secure it against twisting with the lock nut.

TECE push plates – TECEplanus

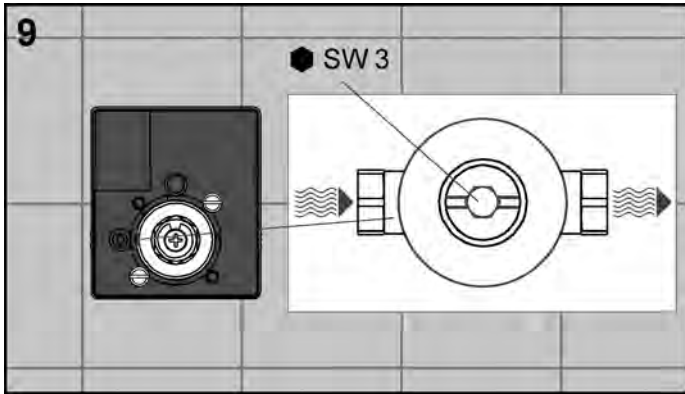

Open the inlet flow control.

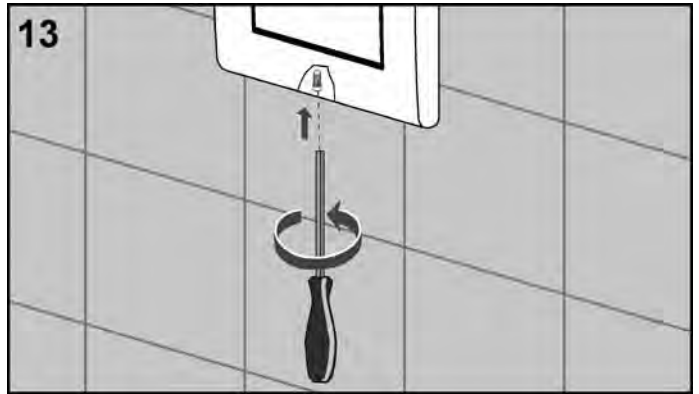

If required, install the supplied vandal-proofing device.

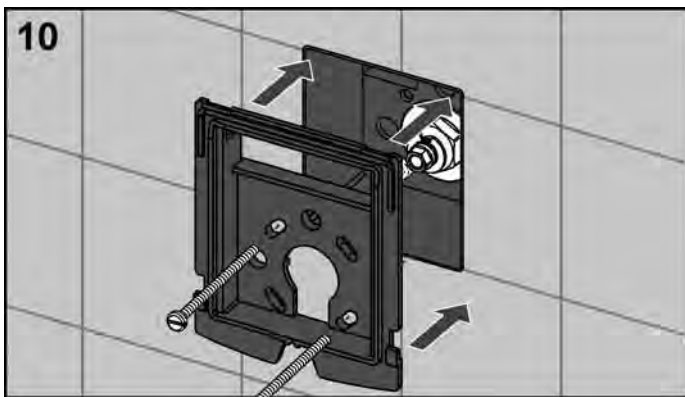

Screw the attaching frame to the urinal flush valve housing.

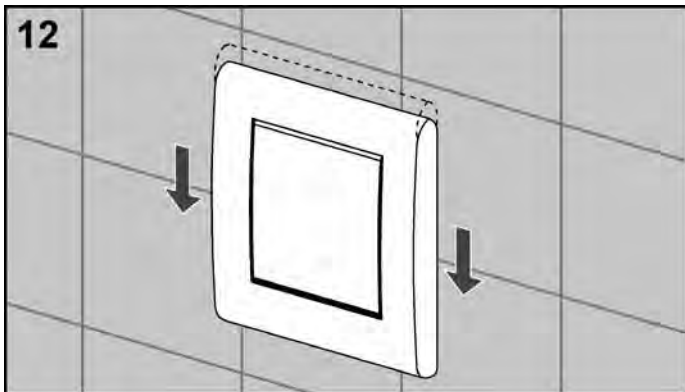
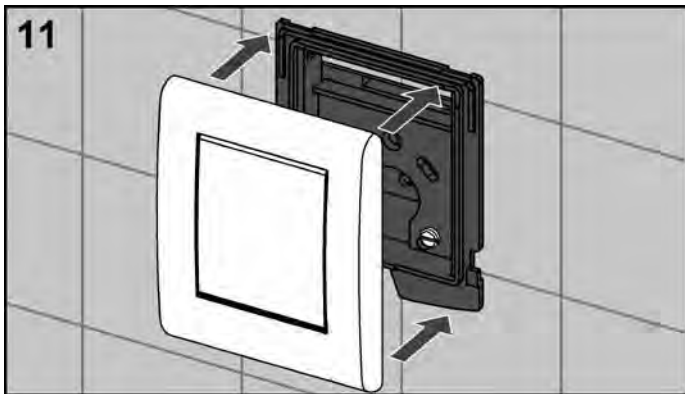

Finally, install the push plate cover.

TECEplanus infrared electronic device

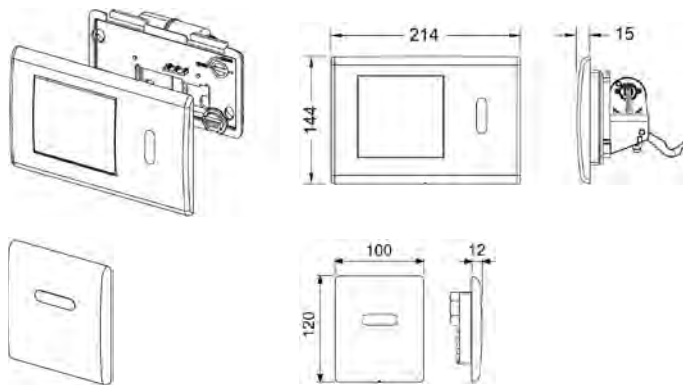

TECEplanus toilet infrared electronic device
TECEplanus urinal infrared electronic device

TECEplanus IR electronic devices are available for the toilet and urinal.

Thanks to a reliable autofocus infrared sensor, they identify use and perform a flush independently.

These electronic devices can be supplied with power either with a 6 V battery or as the 12 V mains version.

NOTE:

A transformer must be used for power supply in the 12 V mains version. A suitable point (concealed socket or similar) must be planned in the bare-wall stage as this may under no circumstances be positioned directly on the push plate. The connection cable between the transformer and the electronic device can be no more than 10 m long.

The TECEplanus IR electronic devices are equipped with a vandal-proofing device and are thus protected against theft.

In the toilet electronic device, a single-volume flush can also be actuated by hand.

TECEplanus toilet infrared electronic device

The toilet electronic device actuates the flush if a person enters the detection range and leaves it again after a predefined minimum period. The following parameters must be borne in mind here:

- The detection range is between 50 and 80 cm.
- Person detection is only completed after a period of at least 16 seconds – in which the user must be in the detection range.
- Actuation is not started until the user has left the detection range:
After 5 seconds, a short tone sounds, after another 2 seconds, the flush is actuated.

If the user returns to the detection area within this 7-second period (5 + 2), flush actuation is stopped and

not started again until the user has left the detection range again and another 7 seconds have passed.

Cleaning function

When the cleaning function is activated, the toilet flush is interrupted for 10 minutes. After this period of time, a cleaning flush is actuated and standard operation restored.

- **Cleaning function activation:**
Hold the programming key in front of the sensor window briefly until you hear the confirmation signal tone.

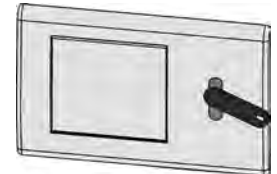

- **Deactivate the cleaning function:**
Hold the programming key in front of the sensor window briefly. Three sequential confirmation signal tones sound – the toilet electronic device is back in standard operating mode.

The cleaning function can only be activated in standard operation – not during the programming phase.

Adjustment of the cistern

During installation of toilet electronic device, the drain valve of the cistern must be adjusted:

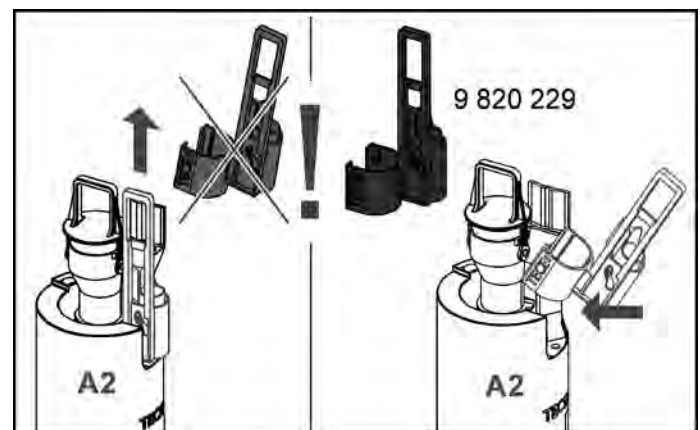

In the case of cisterns installed as of the middle/end of 2009 and that contain the drain valve shown above (A2), the red pull rod of the valve must be replaced with the black one. This is included with the toilet electronic motor or can be ordered as a spare part (order number 9 820 229).

TECE push plates – TECEplanus infrared electronic devices

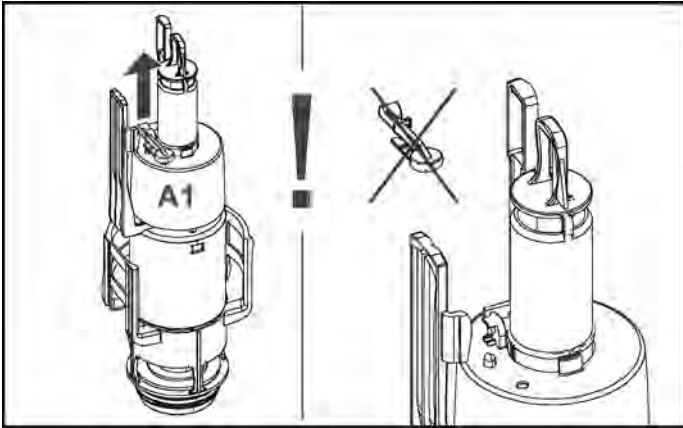

In the case of cisterns installed up to the middle/end of 2009 and that contain the drain valve shown above (A1), only the white guide valve must be removed when a toilet electronic device is installed.

Toilet IR electronic device energy options

■ Mains version:

230 V alternating current is transformed to 12 V direct current by means of TECE transformer (order number 9 810 003, please order separately).

■ Battery operation:

1 x lithium 2CR5 – 6 V

Based on a life of two years, the battery lasts for

- 15,000 flushes or
- approx. 20 flushes/day

Alternatively, you can have battery operation with 4 D cells (LR20). This increases the battery performance to 110,000 flushes, or 150 flushes/day. In addition to the batteries, you also require a different battery housing for this (order number 9 820 202).

Installation of toilet electronic device, 6 V battery

Proceed as follows to install the toilet electronic device in the battery version:

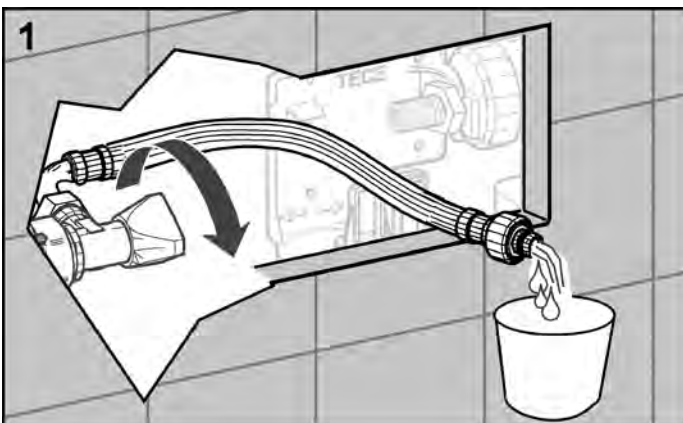

First remove the splash guard with actuation unit – this is no longer required. Open the corner valve and rinse out the pipe thoroughly.

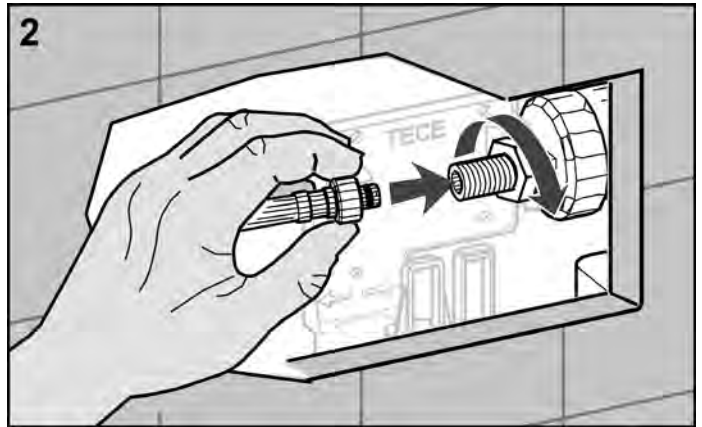

Close the corner valve again and attach the reinforced hose to the filling valve. If you want to fill the cistern with water (for initial start-up or similar), the corner valve must be open again.

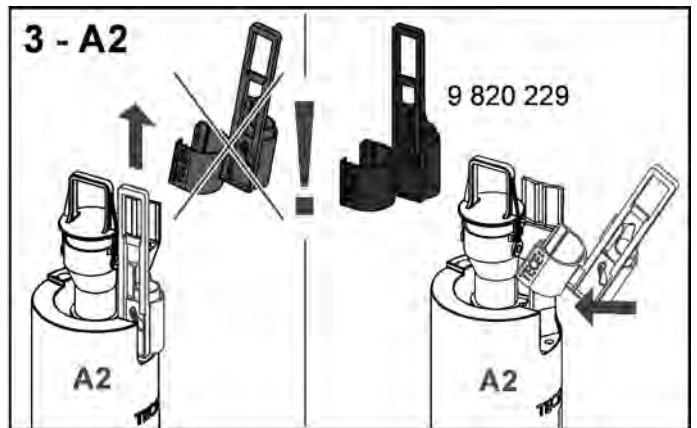

Now adjust the drain valve for the toilet electronic device: For newer cisterns installed as of the middle/end of 2009, you must replace the red pull rod of the valve (A2) with the supplied black rod (figure above).

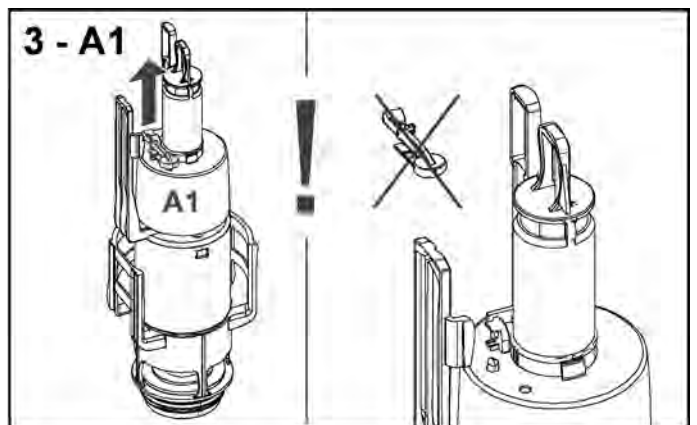

For cisterns up to the middle/end of 2009, you only need to remove the white guide valve of the drain valve (A1).

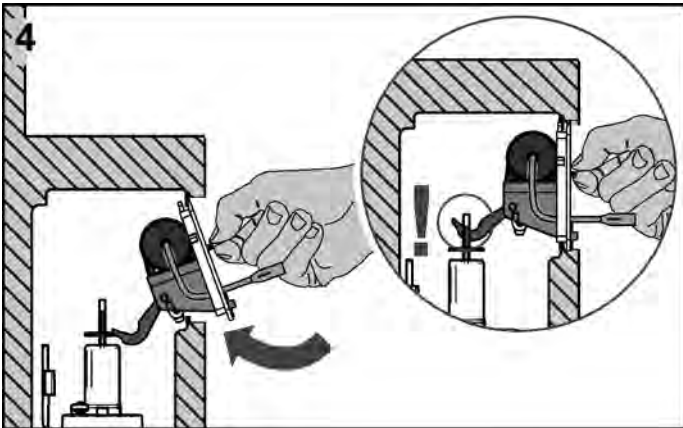

Insert the (new) splash guard of the electronic device with actuating motor. The actuation hooks must sit correctly in the lug of the drain valve. Tighten the attaching screws of the splash guard.

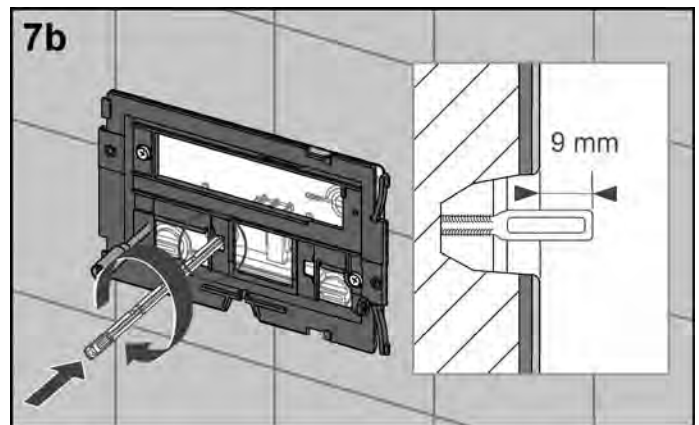
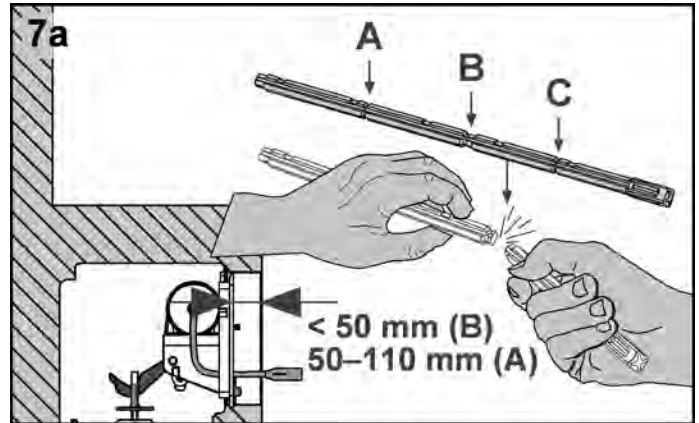

Snap off the actuation rods in accordance with the wall thickness. Screw the actuation rods in and set the distance to front edge of attaching frame to 9 mm.

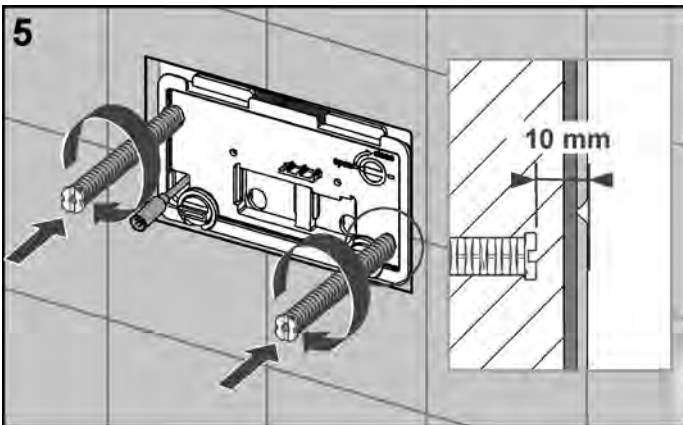

Install both attaching rods and set the distance to the wall surface to 10 mm.

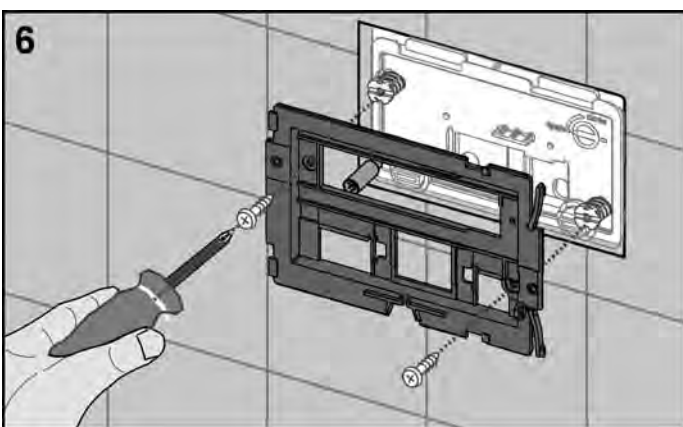

Install the attaching frame.

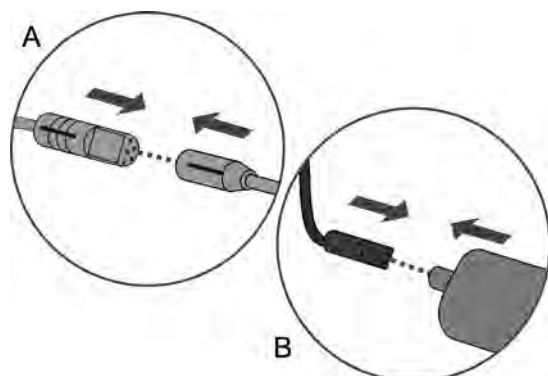
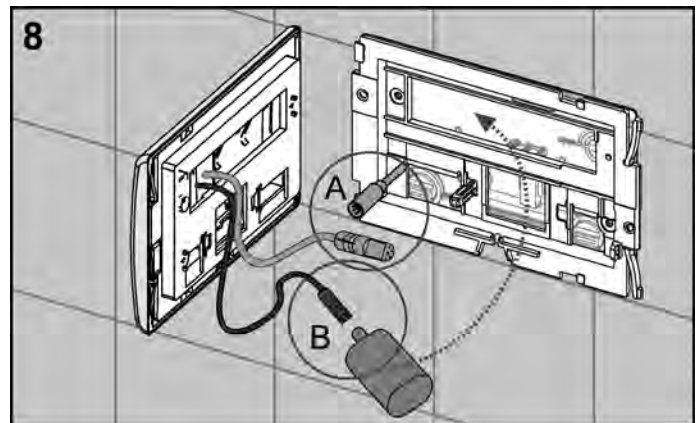

Connect the electronic device to the actuating motor and the battery using the connector. If installation is correct, the motor is automatically actuated once by the electronic

TECE push plates – TECEplanus infrared electronic devices

device as soon as all connectors and the power source have been connected.

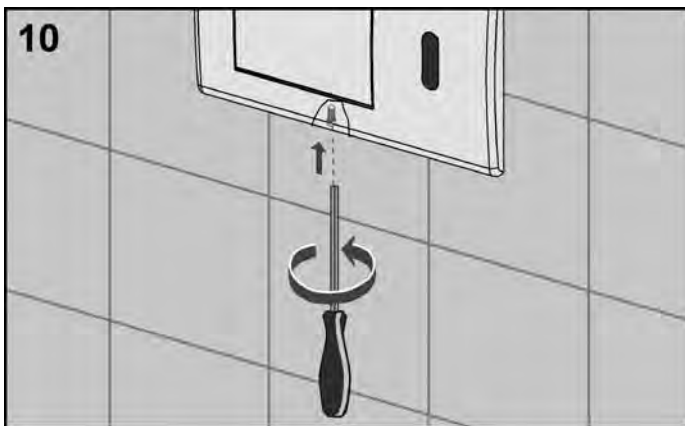
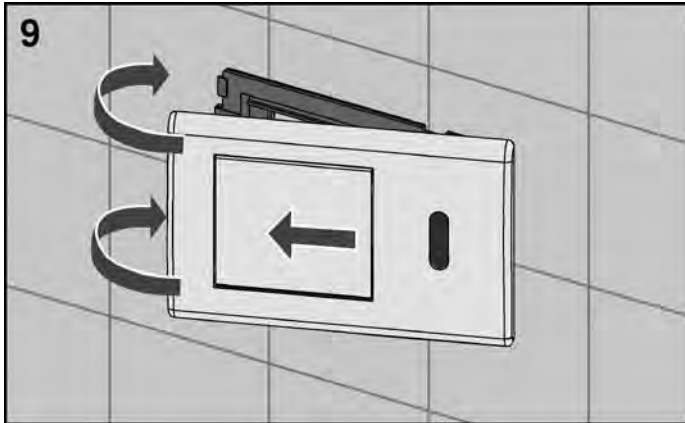

The TECEplanus push plate cover is hooked in on the right and installed on the attaching frame via a catch. Then screw in the vandal-proofing screw into the inner side of the push plate from below (take care not to damage the surface).

Installation of toilet infrared electronic device, 12 V mains

To connect the 12 V mains version, you need a TECE transformer (order number 9 810 003, please order separately) and a connection cable (order number 9 810 004, please order separately) for each toilet push plate.

The steps for installing the toilet infrared electronic device are practically identical (see section "TECEplanus, toilet infrared electronic device installation, 6 V), apart from connection of the electronic device/power supply:

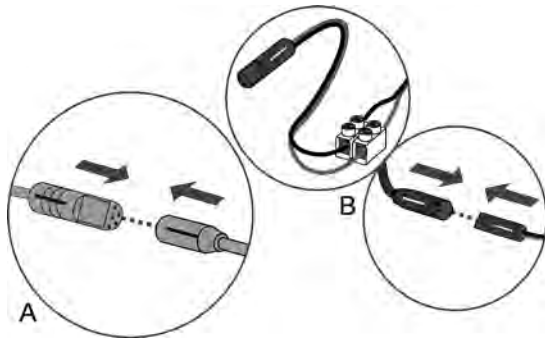
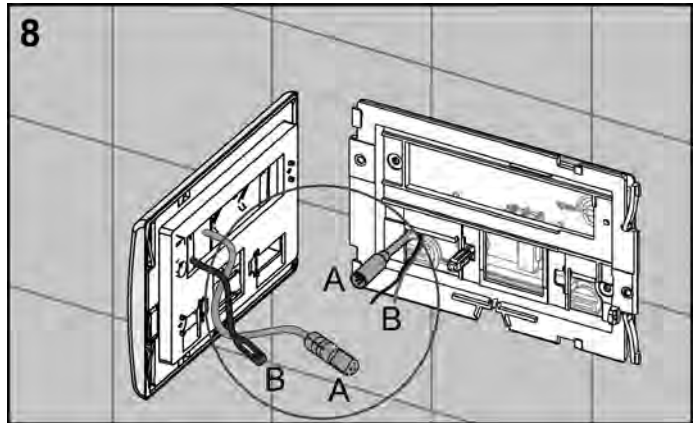

Connect the electronic device to the actuating motor and 12 V mains using the connector or lustre terminal. If installation is correct, the motor is automatically actuated once by the electronic device as soon as all connectors and the power source have been connected.

TECEplanus urinal infrared electronic device

The autofocus sensor of the urinal infrared electronic device measures the angle of incidence of the light that a person reflects, as well as the distance covered. The sensor also detects whether the person is approaching or moving away.

This means that the flush is actuated largely independently of the colour of the user's clothing. The detection range can be fixed exactly and separated from the background. This greatly reduces the risk of incorrect flush actuation.

The TECE autofocus sensor offers many advantages:

- Intelligent PSD technology (Position Sensitive Detection)
- Precise triggering action
- Good black colour recognition
- No sensitivity to changes in light conditions
- Minimum energy consumption with maximum battery life

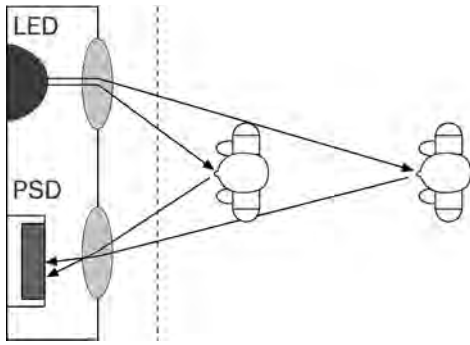

Function of the IR sensor with PSD technology

The toilet electronic device actuates the flush if a person enters the detection range and leaves it again after a predefined minimum period. The following parameters must be borne in mind here:

- The detection range is between 5 and 45 cm.
- Person detection is only completed after a period of at least 6 seconds – in which the user must be in the detection range.
- Actuation is not started until the user has left the detection range.

Break-time function

If the break-time function is activated, the flush volume is automatically reduced to one second if the urinal is used in quick succession (interval of less than two minutes) through a reduction in the flush time. 45 minutes after the last economy flush, a flush with the standard flush volume is actuated.

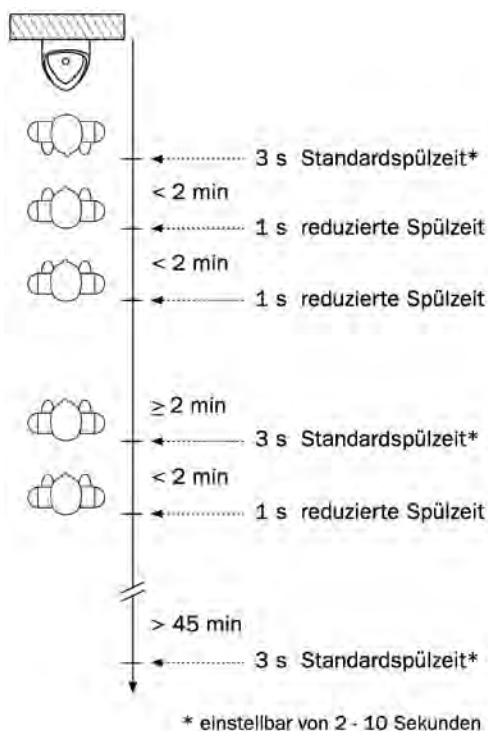

Break-time function

Cleaning function

When the cleaning function is activated, the urinal flush is interrupted for 10 minutes. After this period of time, a cleaning flush is actuated and standard operation restored.

- Activate the cleaning function:
Hold the programming key in front of the sensor window briefly until you hear the confirmation signal tone.
- Deactivate the cleaning function:
Hold the programming key in front of the sensor window briefly. Three sequential confirmation signal tones sound – the urinal is back in standard operating mode.

The cleaning function can only be activated in standard operation – not during the programming phase.

Urinal infrared electronic device programming

After electronic supply has been installed, the electronic device can be programmed within an hour with the help of the magnetic key provided. If you want to change the program again, you must disconnect the power supply. Thanks to a storage module, the most recently configured program is active even if the power fails.

About five seconds after connection to the power supply, the TECE electronic device can be programmed in the first 30 minutes. A position is assigned to each configurable function.

Position	Function
1	Break-time function off
2	Break-time function on
3	Flush time 2 s
4	Flush time 2.5 s
5	Flush time 3 s
6	Flush time 3.5 s
7	Flush time 4 s
8	Flush time 5 s
9	Flush time 6 s
10	Flush time 8 s
11	Flush time 10 s
12	Pre-flush off
13	Pre-flush 0.5 s
14	Pre-flush 1 s
15	Pre-flush 2 s
16	Hygienic flush off
17	Hygienic flush 24 h
18	Hygienic flush 255 h
...	...
23	Distance 5-45 cm
24	Distance 10-40 cm
...	...
28	Factory setting

TECE push plates – TECEplanus infrared electronic devices

In programming mode, the electronic system can be set using a magnetic key. In standard operating mode, this key can be used only to activate the cleaning function.

■ Cleaning function:

When the urinals are being cleaned, the flush function should usually not be activated automatically. There has to be time for the cleaning agents to take effect. The flush function is therefore delayed by ten minutes.

■ Pre-flush (optional):

(Duration 0 - 2 seconds) Helps to dampen the porcelain shortly before use, which prevents urine from sticking. A positive side effect is that the preflush stimulates the need to urinate.

■ Break-time function (optional):

If the urinal is used at intervals of less than two minutes, the water volume is automatically reduced. A cleaning flush is actuated 45 minutes after the last economy flush.

■ Variable flush time:

(Duration 2 - 10 seconds) The flush volume can be adjusted to suit requirements by adjusting the flush time.

■ Distance:

The state-of-the-art autofocus optical sensor functions reliably in a very wide range of building situations. Nevertheless, the optical detection range can be altered in the case of extremely small or large urinal facilities.

■ Hygienic flush (optional):

If this function is activated, regular additional flushes prevent the siphon from drying out, as well as removing the associated smells and accumulation of residues (either 24 or 255 hours after the last flush).

■ Top up siphon (optional):

Today's urinals usually completely drain the siphon and then top up enough water to fill the siphon again. If this does not work, the top-up function of the TECE electronic device can be activated and a short flush pulse fills the siphon.

How to program the TECE electronic device:

- Hold the programming key in front of the sensor window. Programming mode starts with a series of quick signal tones.

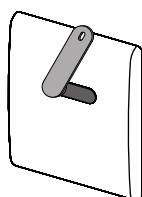

- After the start phase, a series of identical individual signal tones can be heard. Count these up to the required function.
- Then remove the programming key; you hear a long confirmation signal tone.

Example: Set the flush time to three seconds

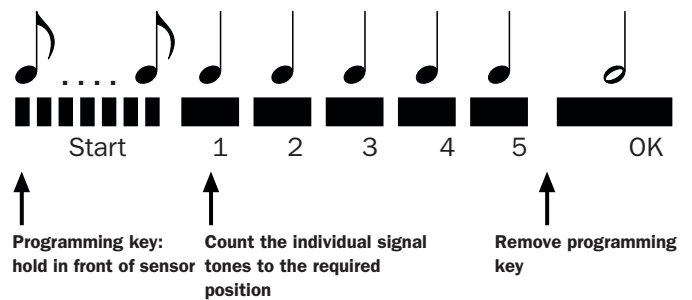

Energy options of the urinal electronic device for radio actuation

■ Mains version:

230 V alternating current is transformed to 12 V direct current by means of TECE transformer (order number 9 810 003, please order separately).

■ Battery operation:

1 x 2 CR 5 lithium – 6 V

Based on a life of two years, the battery lasts for

- 220 000 flushes or
- approx. 300 flushes/day

Technical data

The following flow graph will help you calculate the flush volume of the urinal flush valve dependent on the pipe pressure and flush time.

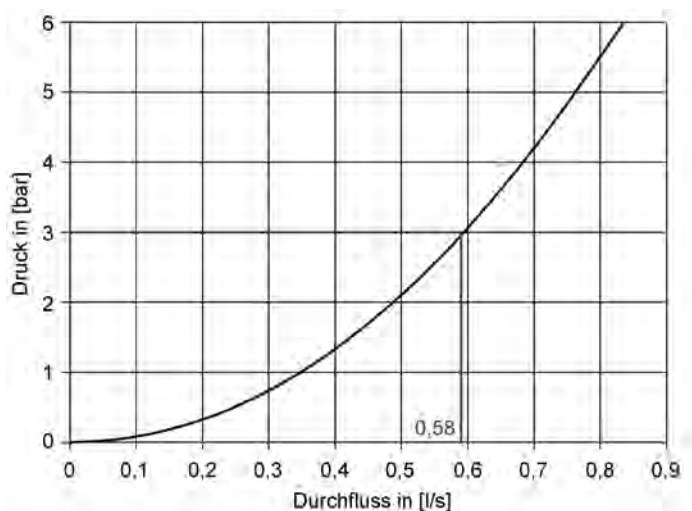

Urinal flow graph

Example:

Pipe pressure 3 bar: Flush flow rate = 0.58 l/s

Flush time e.g. 3.5 s: Flush volume approx. 2 litres

Urinal infrared electronic device, 6 V battery

Minimum flow pressure	0.5 bar
Max. operating pressure	12 bar
Flow at 3 bar	0.58 l/s
Operating voltage	6 V DC
Power input	1 W
Max. power input	5 W
Battery type	lithium 6 V, 2 CR 5
Life, battery	approx. 3 years
Protection class	III
	Safety extra low voltage (SELV)

Flush time, factory setting	3 s
Flush time, setting range	2–10 s
Pre-flush, factory setting	off
Pre-flush, setting range	0.5–2 s
Break-time function, factory setting	off
Hygiene flush, factory setting	off

Urinal infrared electronic device, 12 V mains

Minimum flow pressure	0.5 bar
Max. operating pressure	12 bar
Flow at 3 bar	0.58 l/s
Voltage rating	230 V
Operating voltage	12 V (± 20 %)
Power input	1 W
Max. power input	5 W
Protection mode	III
	Safety extra low voltage (SELV)
Flush time, factory setting	3 s
Flush time, setting range	2–10 s
Pre-flush, factory setting	off
Pre-flush, setting range	0.5–2 s
Break-time function, factory setting	off
Hygiene flush, factory setting	off
Hygiene flush, setting range	off, 24 h, 255 h

Transformer 230 V/12 V mains

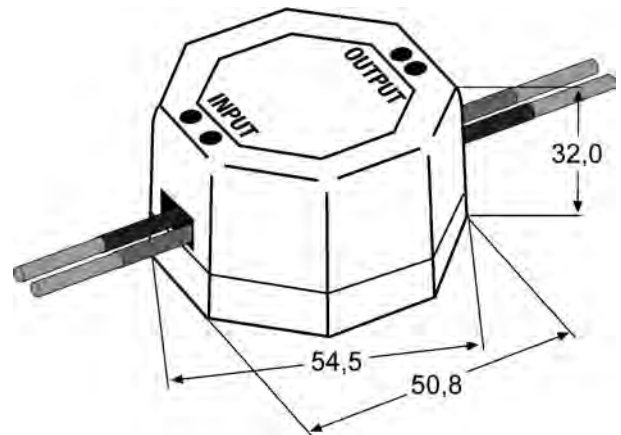

Input voltage	230 V AC (± 20 %)
Frequency	48–63 Hz
Outp. voltage rating	12 V DC (± 20 %)
Output voltage tolerance	± 3 %
Residual ripple	< 50 mVpp
Outp. nominal current	1.0 A
Nominal power	6 W
Minimum load	0
Effectiveness	75 %
Overload protection	electronic
Short circuit protection	electronic
Protection mode	IP 20
Protection class	II
	CE low-voltage supply
Operating temperature	– 20 °C to + 40 °C
Safety standard	EN 61 558 / EN 60 950
EMV standard	EN 55 022/B
Technology	Switching
Switching frequency	100 KHz
Dielectric resistance	3 750 V/1 min
MTBF (MIL HDBK217)	120 000 h

Push plates

TECE push plates – TECEplanus infrared electronic devices

Installation of urinal infrared electronic device, 6 V battery

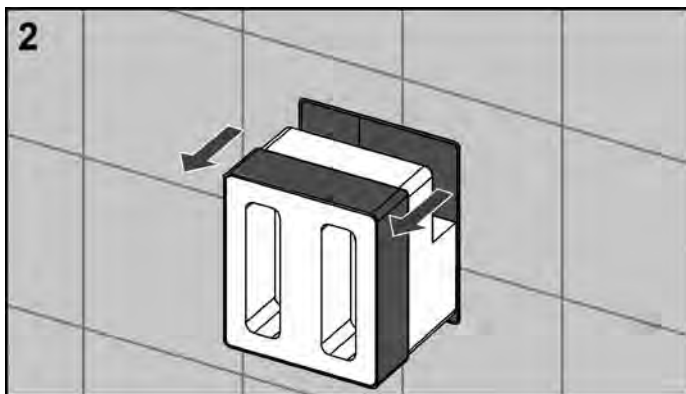
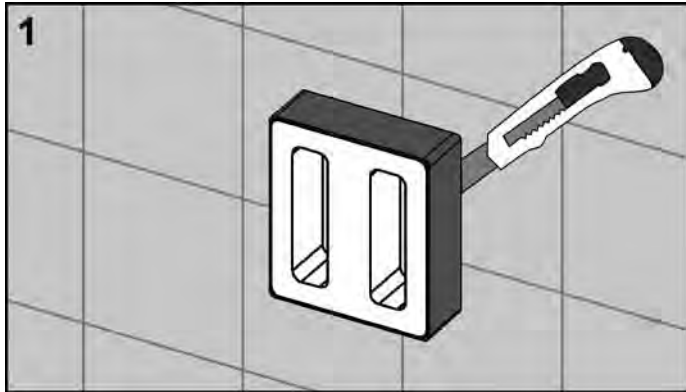

Cut off the bare-wall protection flush to the wall and remove it together with the polystyrene support.

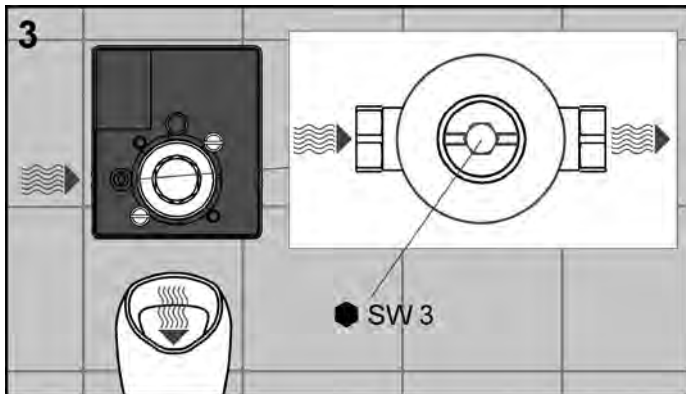

Rinse the pipe thoroughly.

NOTE:

In the pressure test, the inlet flow control of the flush valve must be set to through flow.

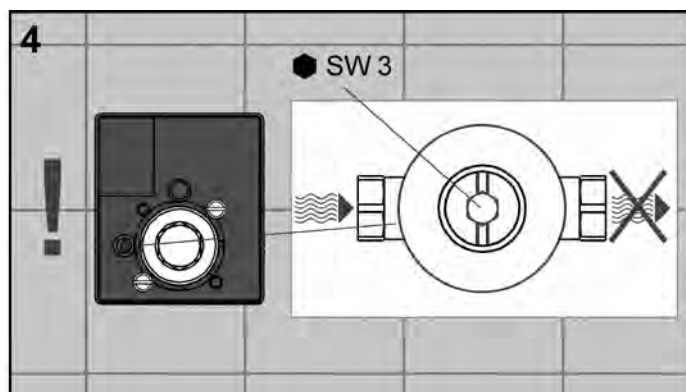

Before installing the cartridge, make sure that the inlet flow control is closed, so that no water escapes during installation. Close the flow control using a hexagonal wrench. In through-flow setting (figure 3), the groove of the flow control runs parallel to the flush valve housing, when the setting is closed (figure 4), it is at right angles to the housing.

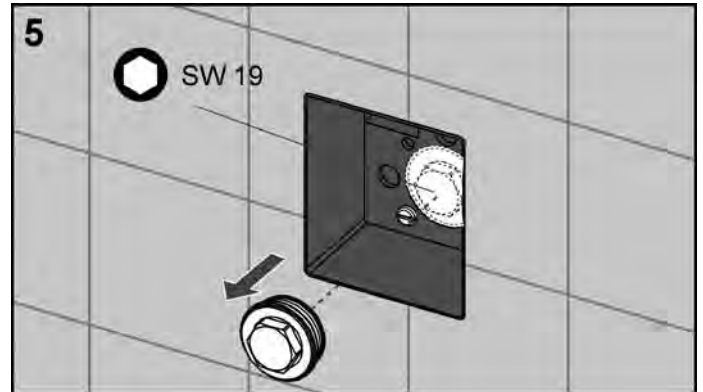

Remove the bare-wall plug.

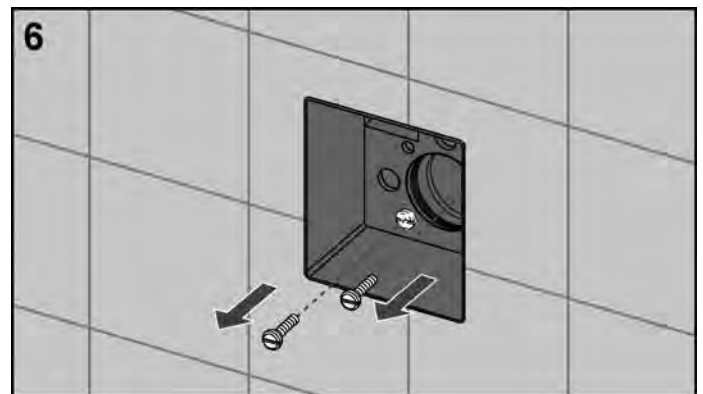

Unscrew the attaching screws of the bare-wall protection.

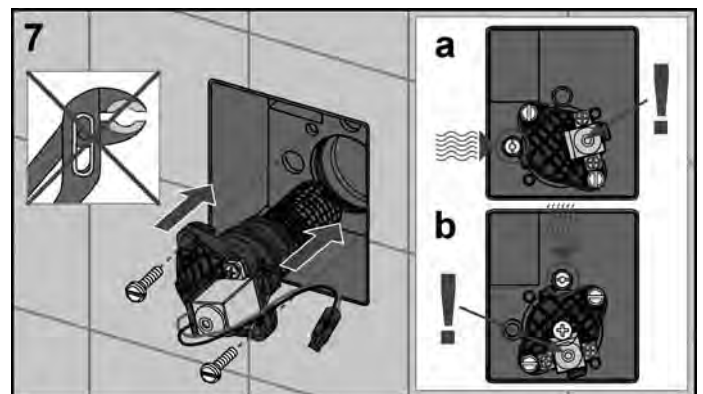

Install the electric cartridge (do not touch with tools) and tighten the screws by hand.

Please note:

When installing the electronic cartridge, the correct position is extremely important. As shown in the right-hand part of the figure above, the position also depends on the installation situation of the flush valve housing: Housing horizontal = flow control left, electronic device right (figure

7a); housing vertical = flow control top, electronic device bottom (figure 7b). If the cartridge is installed incorrectly, it may function initially, but will fail after a certain amount of time.

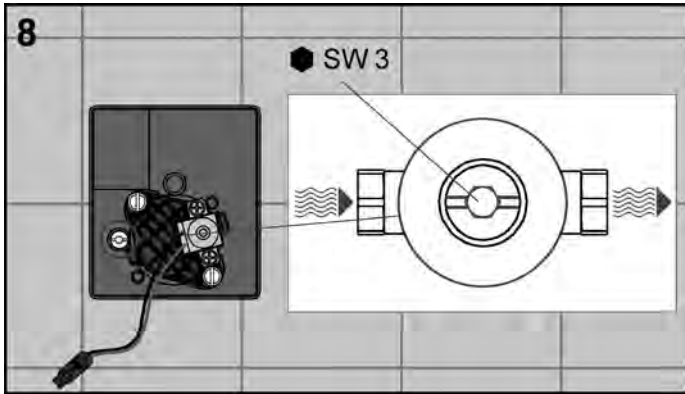

Open the inlet flow control.

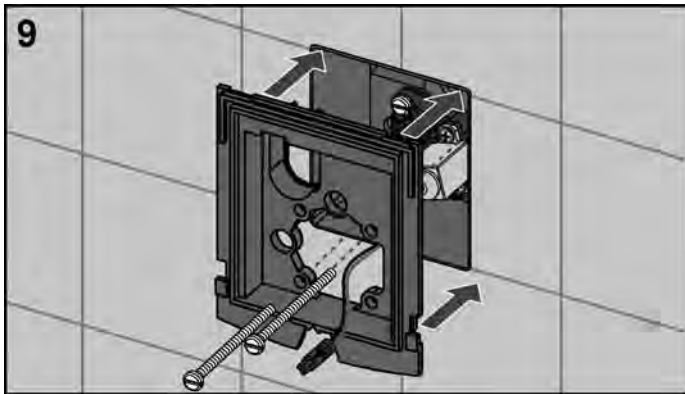

Screw the attaching frame to the urinal flush valve housing.

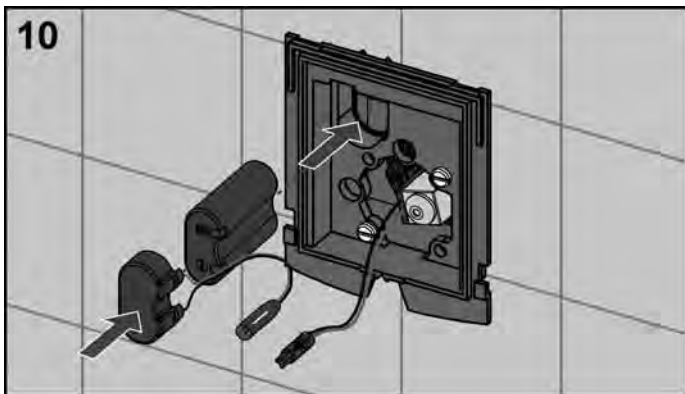

Insert the connection adapter onto the battery and place this in the intended opening.

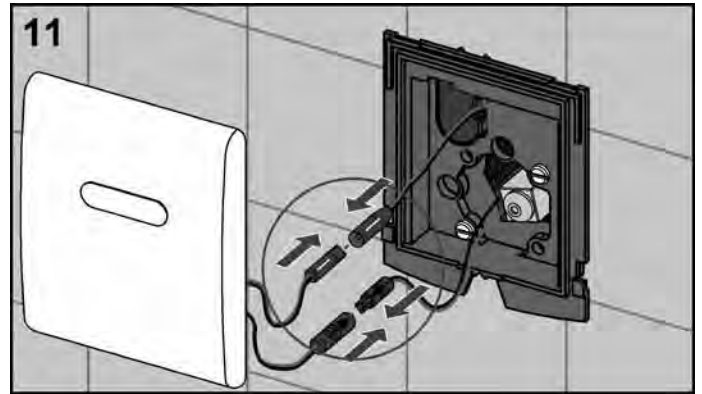

Connect the battery and cartridge to the electronic device.

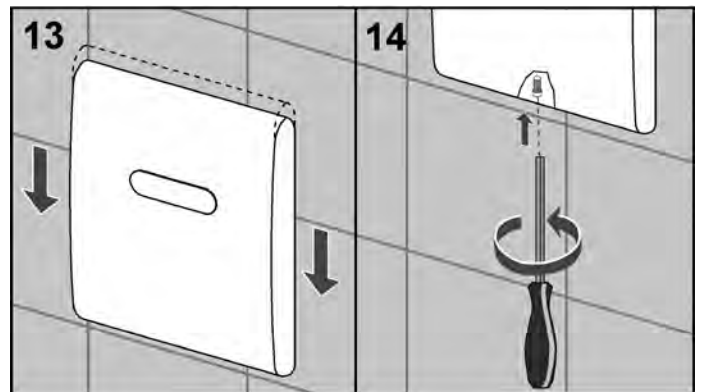
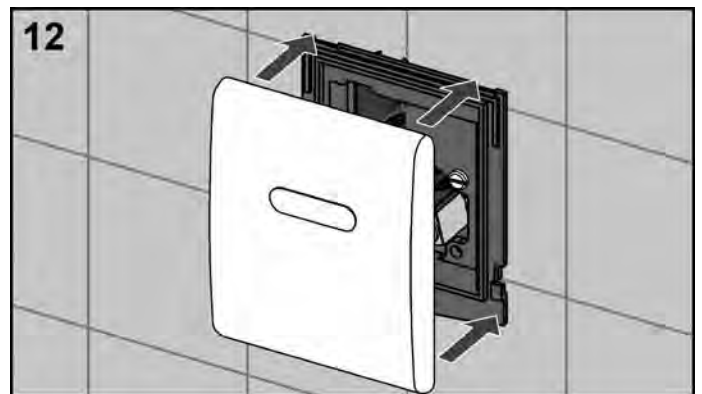

Finally, install the push plate cover and the vandal-proof device provided.

TECE push plates – TECEplanus infrared electronic devices

Installation of urinal infrared electronic device, 12 V mains

CAUTION

Note the following information when installing a 12 V version:

- A maximum of 5 electronic devices can be simultaneously connected to the transformer.
- The 12 V mains electronic devices must be connected in parallel in a series installation.
- The connection cable between the connection on the transformer and the furthest electronic device can be no more than 10 m long.

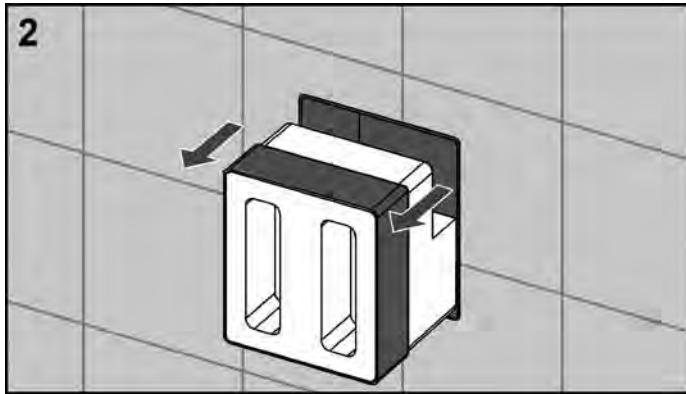
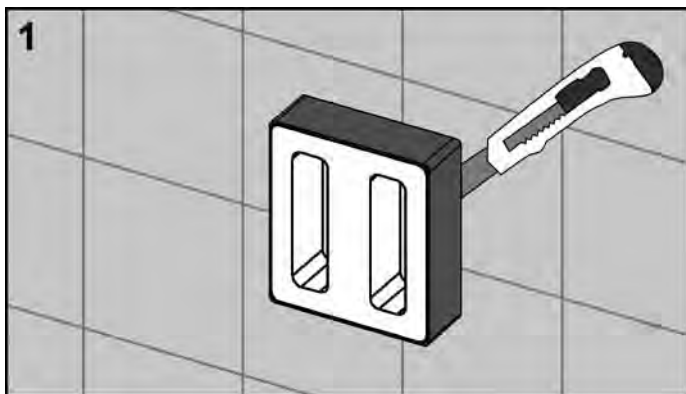

Cut off the bare-wall protection flush to the wall and remove it together with the polystyrene support.

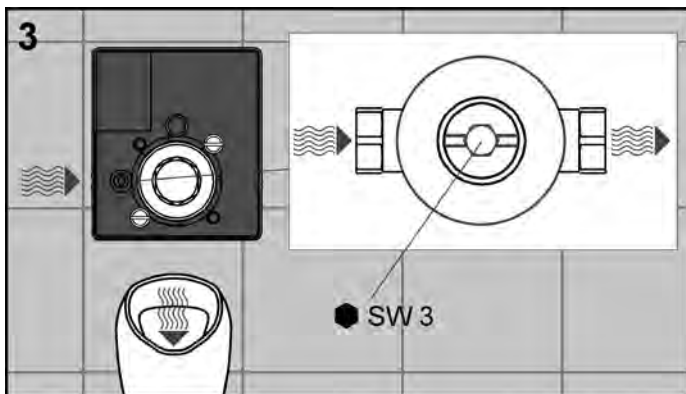

Rinse the pipe thoroughly.

NOTE:

In the pressure test, the inlet flow control of the flush valve must be set to through flow.

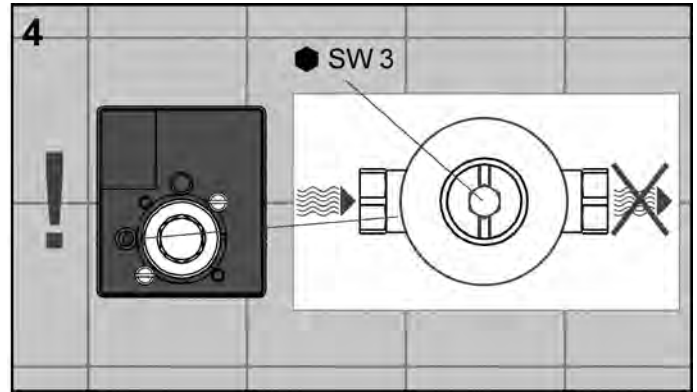

Before installing the cartridge, make sure that the inlet flow control is closed, so that no water escapes during installation. Close the flow control using a hexagonal wrench. In through-flow setting (figure 3), the groove of the flow control runs parallel to the flush valve housing, when the setting is closed (figure 4), it is at right angles to the housing.

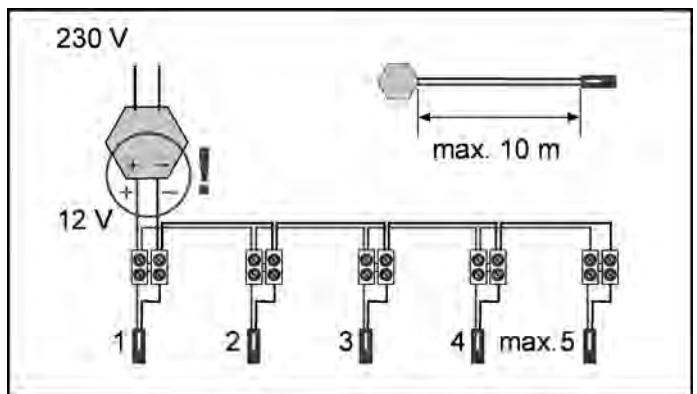
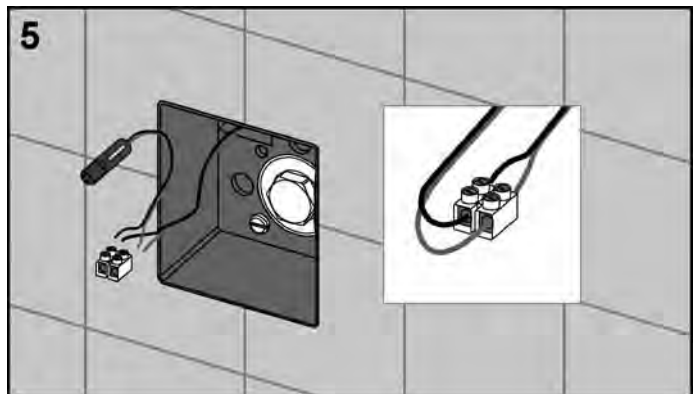

Connect the cable of the transformer to the mains connection adapter. Make sure the polarity of the connections is correct.

Take account of the maximum number of connected electronic devices (= 5) and the maximum length of the connection line (= 10 m).

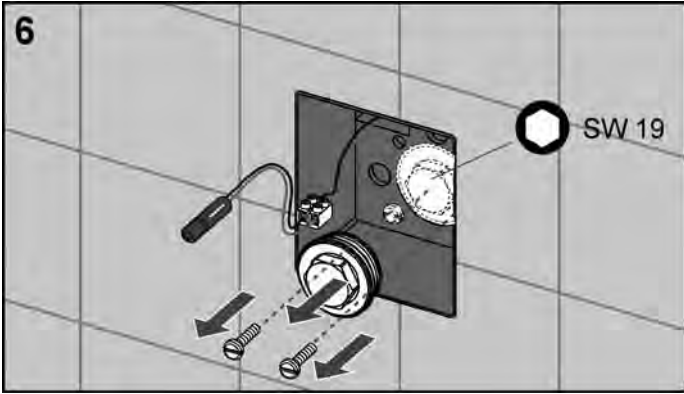

Remove the bare-wall plug and unscrew the attaching screws of the bare-wall protection.

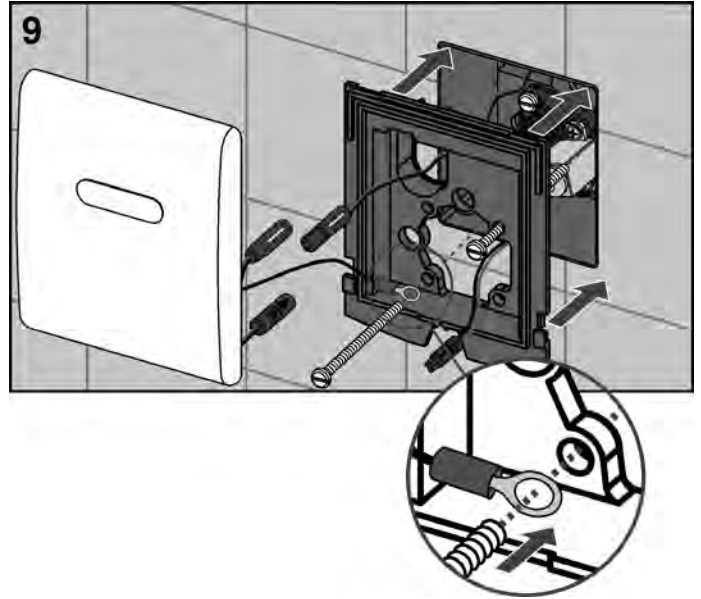

Earth the electronic device by means of the attaching screw on the flush valve housing (see detail) and screw the attaching frame onto the urinal flush valve housing.

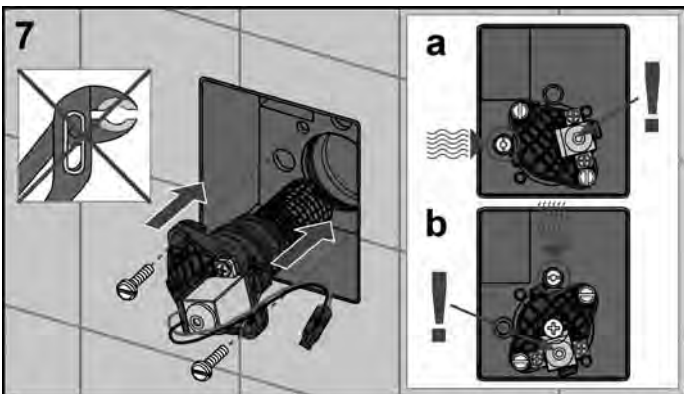

Install the electric cartridge (do not touch with tools) and tighten the screws by hand.

Please note

When installing the electrical cartridge, the correct position is extremely important. As shown in the right-hand part of the figure above, the position also depends on the installation situation of the flush valve housing: Housing horizontal = flow control left, electronic device right (figure 7a); housing vertical = flow control top, electronic device bottom (figure 7b). If the cartridge is installed incorrectly, it may function initially, but will fail after a certain amount of time.

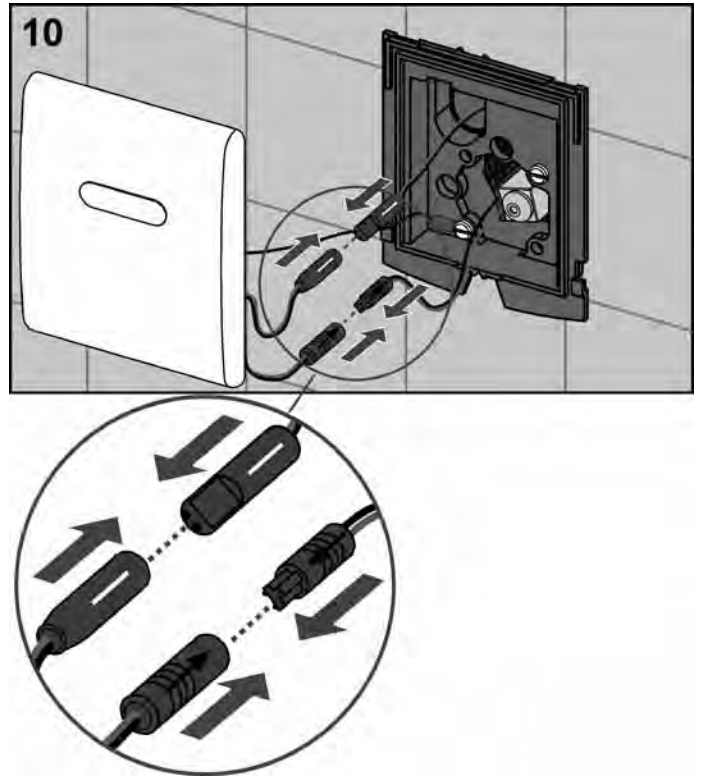

Connect the battery and cartridge to the electronic device.

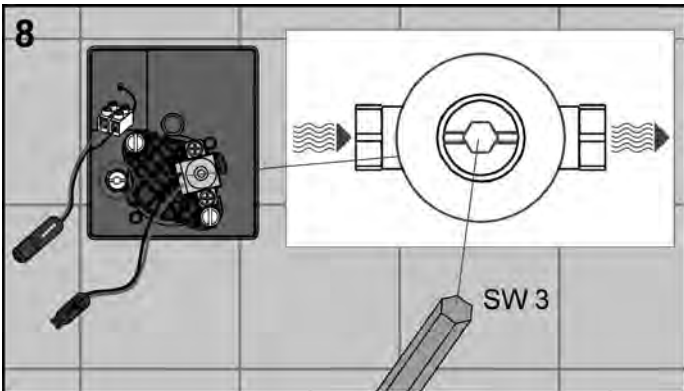

Open the inlet flow control.

TECE push plates – TECEplanus infrared electronic devices

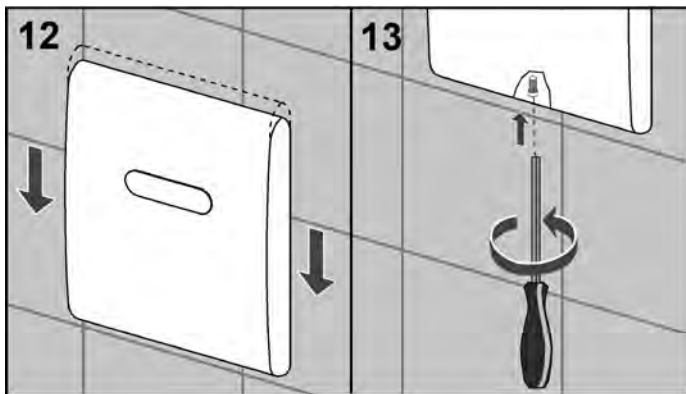
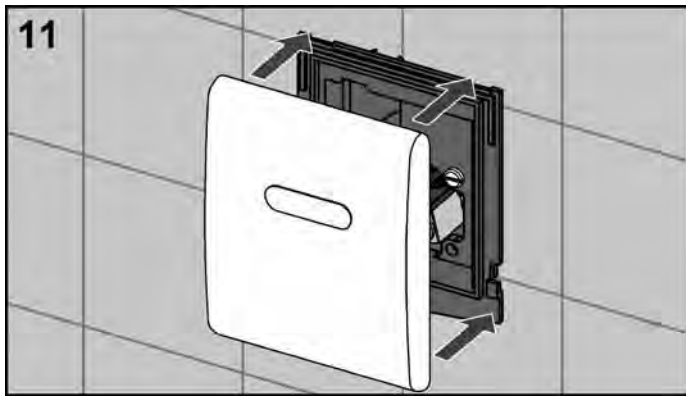

Finally, install the push plate cover and the vandal-proof device provided.

TECEplanus electronic devices, radio actuation

Electrically actuated flush systems are also available if safety support arms are used. You can install a remote button for electronic actuation on the safety support arm.

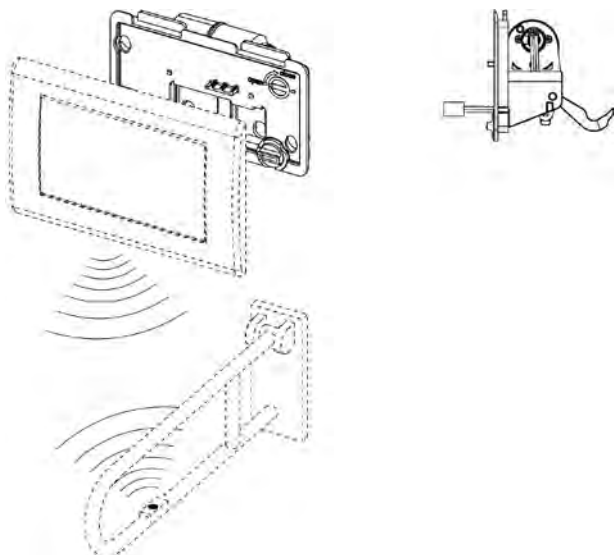

Energy options of the toilet electronic device for radio actuation

- Mains version:
230 V alternating current is transformed to 12 V direct current by means of TECE transformer (order number 9 810 003, please order separately).
- Battery operation:
4 x LR20 D cell – 6 V

Based on a life of two years, the batteries last for

- 190 000 flushes or
- approx. 260 flushes/day

NOTE

A transformer must be used for power supply in the 12 V mains version. A suitable point (concealed socket or similar) must be planned in the bare-wall stage as this may under no circumstances be positioned directly on the push plate.

A push plate is not included in the delivery. With radio actuation, you can use any single-volume push plate; all dual-volume push plates are also possible (e.g. TECEloop, TECEsquare). However, only the large volume is flushed, even if both actuation rods are installed.

TECEplanus remote button

The TECEplanus remote button (order number 9 240 360) can be retrofitted for most safety support arms and fits the TECEplanus toilet remote (radio) actuation.



TECEplanus remote button

Start-up procedure

Prior to fitting the remote button to the safety support arm, the batteries supplied have to be placed in the unit:

- Turn the screw on the rear side of the housing and open the cover. Place the two batteries as marked in the housing.
- The volume of the audible beep for acoustic flush confirmation can be set only when the housing is open: We recommend the factory setting full volume.
- To reduce the volume, turn the dial to the left. To increase the volume, turn it to the right.



Volume dial

Now close the housing again tightly.

- Make sure you position the housing lid correctly: A sealing ring has been fitted in the lid, which prevents water from getting inside.
- When screwing down the housing lid, make sure that the sealing ring makes tight contact to the lock screw.

TECE push plates – TECEplanus electronic devices, radio actuation

Installation

The radio transmitter is supplied with two pre-mounted fastening clamps for screw fastening to the support arms up to a pipe diameter of 33 mm.

- Undo the screw connections of the universal clamps. Subsequently use these two clamps to fasten the radio transmitter to the upper or lower pipe (depending on the support arm).
- Tighten the screws after you have positioned the radio transmitter.

Depending on the required position of the transmitter, the radio transmitter can be fitted to the support arm in any position (to the left or right of the toilet).

Programming the radio transmitter

Prior to the first use, the radio transmitter has to be programmed to communicate with the respective receiver (component part of the corresponding flushing system). Every receiver has a corresponding button as well as an LED for this purpose.

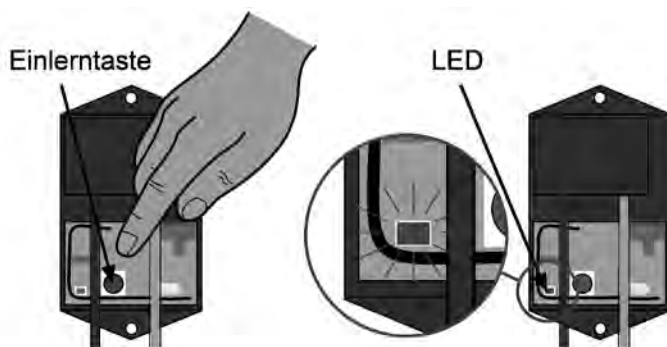

Programming the remote button

- In order to start the programming process, press programming button on the receiver. This action will be acknowledged optically by the receiver by a one-time flash of the LED.
- Now, press the flush actuation surface of the radio transmitter within thirty seconds. Three flashes of the LED indicate the successful programming of the radio transmitter.

Flushing function

After successful programming, the toilet can be flushed by approaching the release surface of the radio transmitter (approx. 3 to 5 mm in front of the surface) or by touching this surface. A successful flushing signal will be acoustically acknowledged with a beep.

Technical data

Frequency	868.4 MHz
Addressing	Individual 32 bit address, programmable at the receiver
Range	10 m maximum
Functions	Flushing action for compatible toilet controls
Release	Capacitive push-button, acoustic acknowledgement by beep

Power supply	3 VDC (2 x alkaline battery LR-1)
Battery life	Approx. 3 years or 100,000 flushes
Housing	ABS housing - approx. 85 x 46 x 16 mm
Assembly	By clamps on safety support arm
Colour	Black (RAL 9005)
Degree of protection	IP 54
Compatible toilet controls	TECEplanus 9 240 354 TECEplanus 9 240 355 Geberit 115.867 Sanit 03.082.00.0000 Viega 462.376

Compatible radio electronic device for TECE radio actuation (868,4 MHz) – safety support arms (folding) and arm-independent radio transmitters

Manu-facturer	Article	Article No.
AMS	Radio actuator, can be installed on AMS support arms	533390
DEUBAD	Remote radio actuation	DEU FK100
Erlau	Radio transmitter FMI/E Radio transmitter FMI/O	8102213 8102214
Frelu	Transmitter for cable-free toilet flush actuation	OP10 radio
FSB	Radio-controlled button	8248 0002
GEBERIT	Hytronic button	241,568.00.1
GROHE	Radio transmitter	100620
HEWI	Toilet flush actuation (radio) upgrade kit ..., left ..., right	802.50.060 802.50.060L 802.50.060R
KEUCO	Folding support arm with integrated radio actuation ... 700 mm right ... 700 mm left ... 850 mm right ... 850 mm left	34903011737 34903011738 34903171737 34903171738 34903012737 34903012738 34903172737 34903172738 34903011837 34903011838 34903171837 34903171838 34903012837 34903012838 34903172837 34903172838
Lehnen	Radio transmitter (with universal clamp) Radio transmitter (white housing)	FA10-001 FA30-001
Standard construction	Radio transmitter NY.WCR 435, can be retrofitted	0449010
PBA	Universal radio transmitter	not known
Pressalit Care	Radio transmitter 868.4 MHz	R9341
Wagner	Universal radio transmitter	600063

Toilet electronic device, radio actuation, 6 V battery

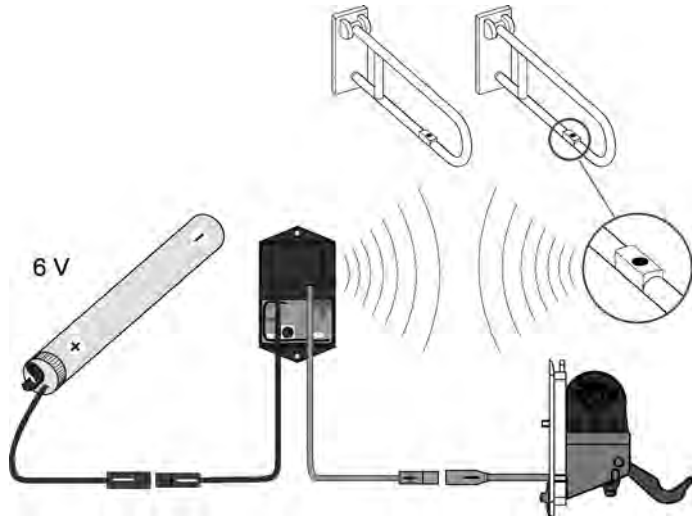

The radio pulse sent from the radio transmitter on actuation is received by a radio receiver. This receiver unit switches the electric circuit for triggering the actuating motor. Power is supplied by four batteries contained in a watertight housing in the cistern.

Installation of toilet electronic device, radio actuation, 6 V battery

Proceed as follows to install the toilet electronic device - radio actuation in the battery version:

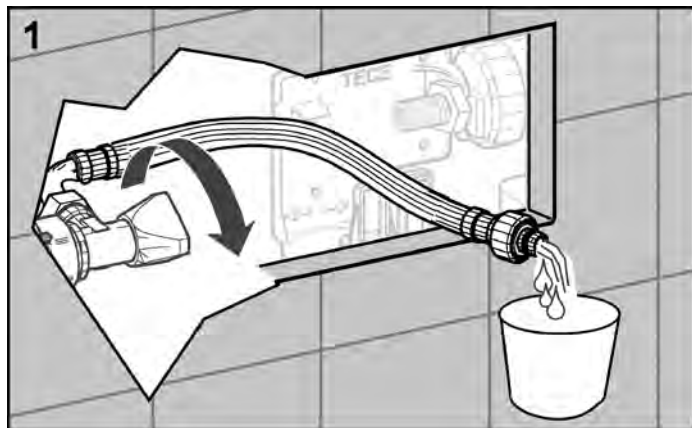

First remove the splash guard with actuation unit – this is no longer required. Open the corner valve and rinse out the pipe thoroughly.

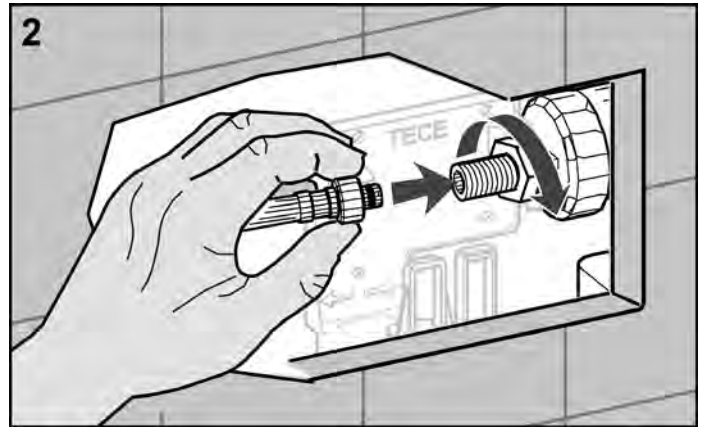

Close the corner valve again and attach the reinforced hose to the filling valve. If you want to fill the cistern with water (for initial start-up or similar), the corner valve must be open again.

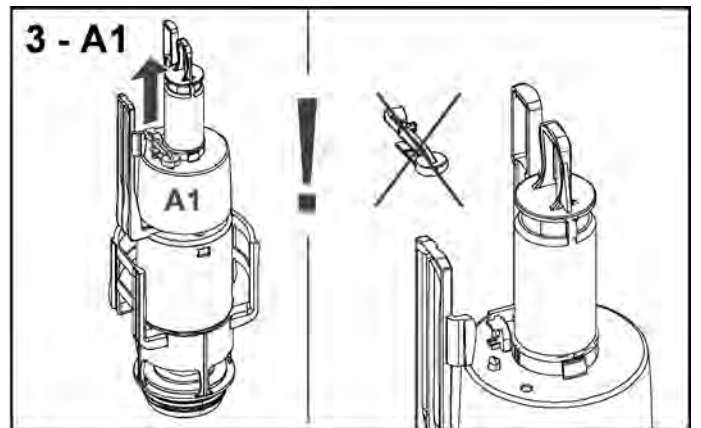
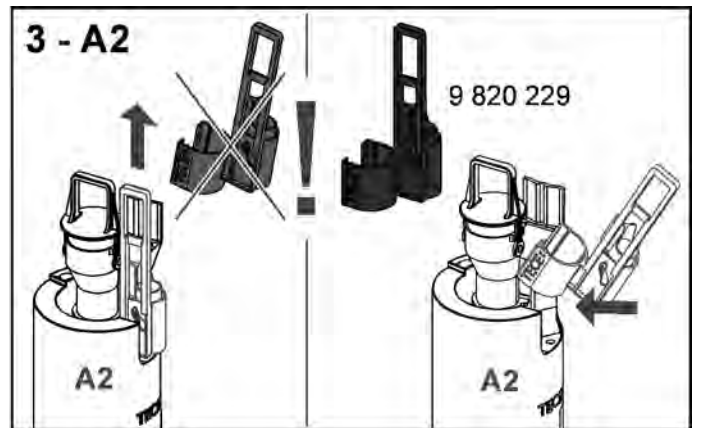

Now adjust the drain valve for the toilet electronic device: For newer cisterns installed as of the middle/end of 2009, you must replace the red pull rod of the valve with the supplied black rod (figure above 3 - A2). For cisterns up to the middle/end of 2009, you only need to remove the white guide valve of the drain valve (figure 3 - A1).

TECE push plates – TECEplanus electronic devices, radio actuation

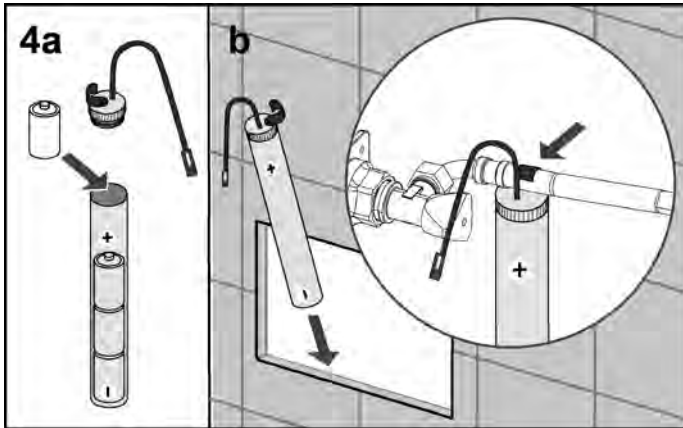

Place the four batteries in the housing and hang the watertight battery compartment on the reinforced hose in the cistern.

The next steps differ depending on the toilet module used: Either a TECE Geronto module with conduits for cable routing and installation box for holding the electronic device, or a different TECE module without conduits, is installed.

... Geronto module with conduits

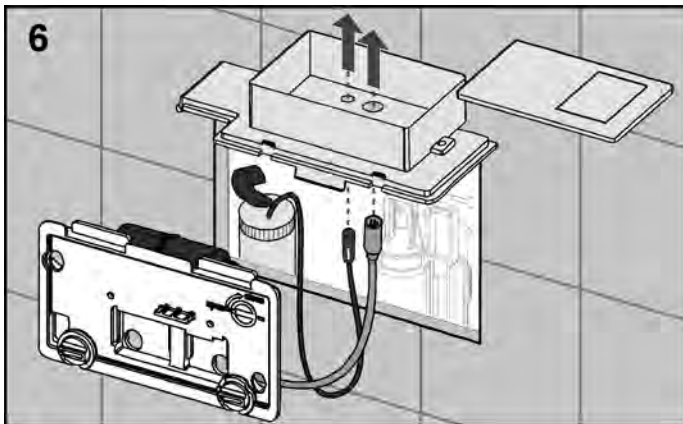
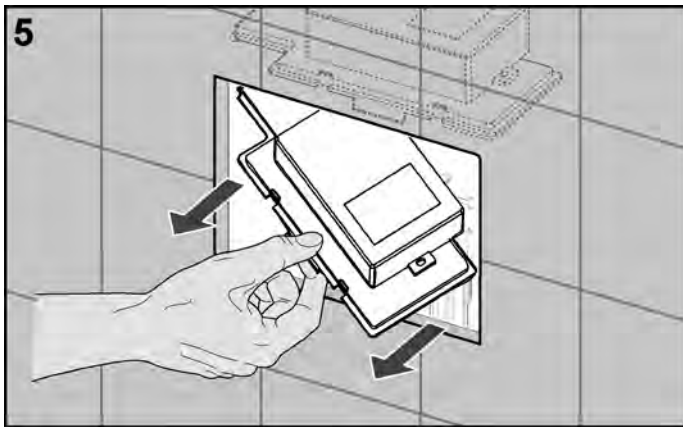

Open the lid of the cistern and remove it with the installation box. Guide the battery and actuating motor connections from below through the openings in the bottom of the box.

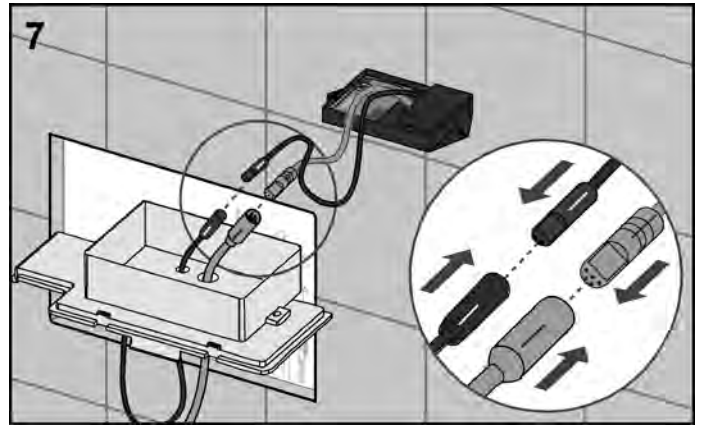

First connect the radio electronic device to the motor (black connectors) and then to the batteries (grey connectors). If installation is correct, the motor is actuated once to check this.

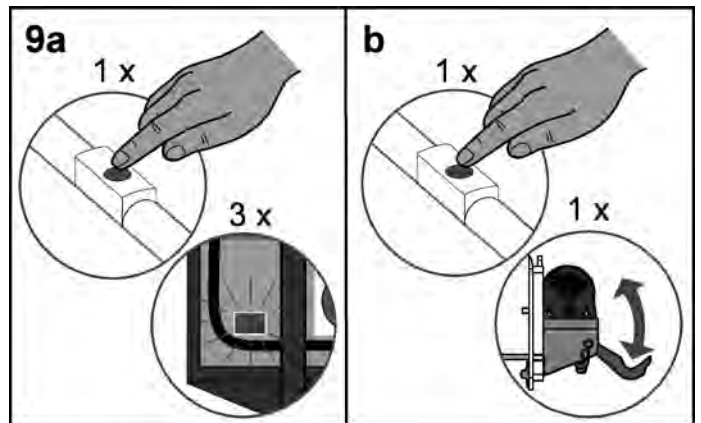
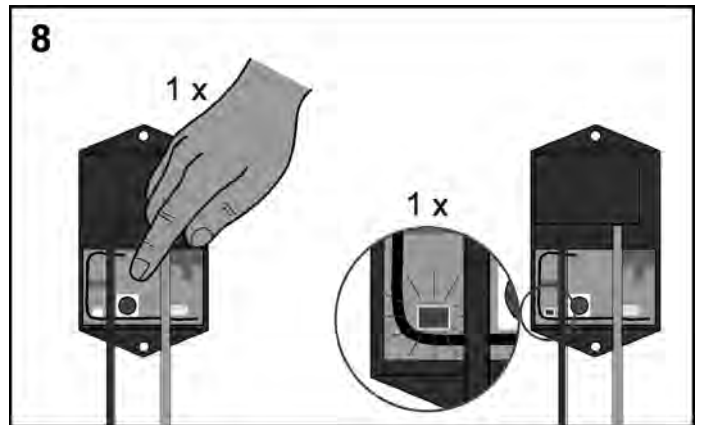

After the radio receiver has been installed it must be adjusted to the signal of the button on the support arm. To do this, press the blue button on the receiver electronic device; the adjacent LED illuminates briefly once (figure 8). After this procedure, the receiver is ready-to-receive for one minute. In this space of time, the button on the safety support arm must be actuated once to establish the connection with the receiver electronic device. If connection is successful, the control LED of the receiver unit flashes three times after the button has been pressed.

Now check the motor function. To do this, press the button again once and thus actuate the motor once.

... Toilet module (dry-wall and brick-wall construction) without conduits

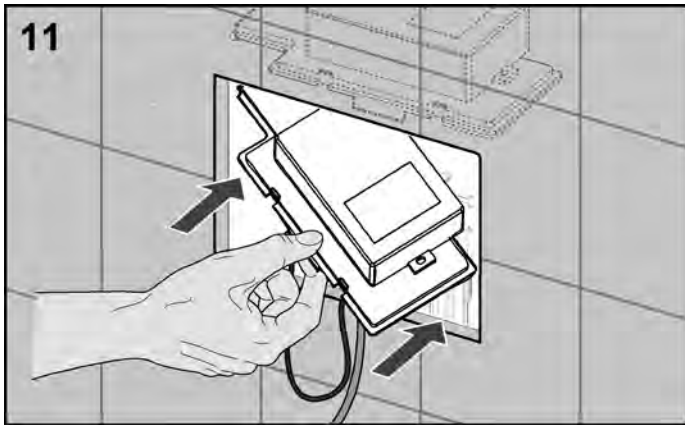
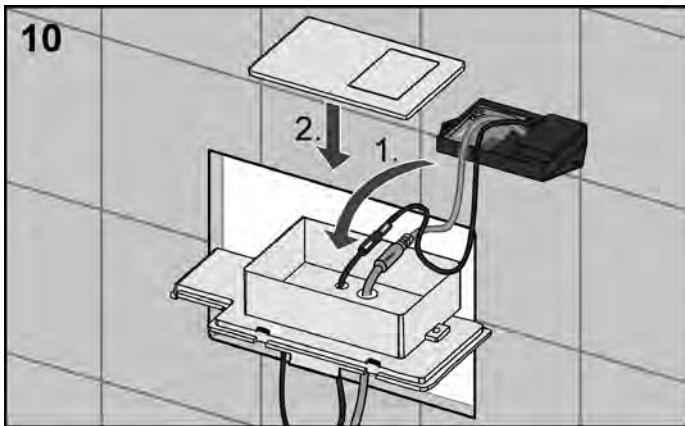

Place the electronic device in the installation box, close this, and install it in the cistern again.

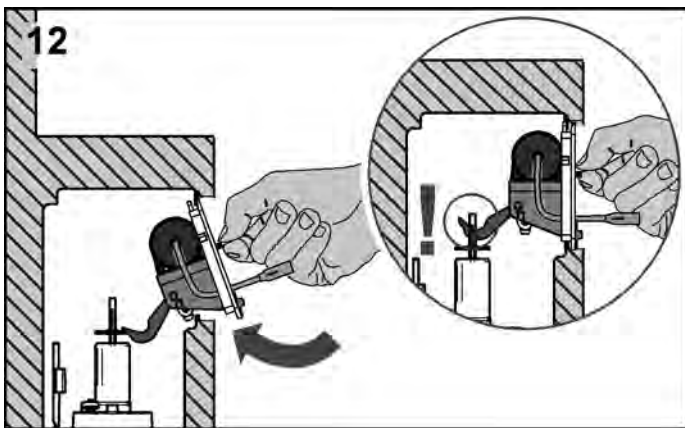

Insert the splash guard of the electronic device with actuating motor. The actuation hooks must sit correctly in the lug of the drain valve. Tighten the attaching screws of the splash guard.

You can then install the push plate.

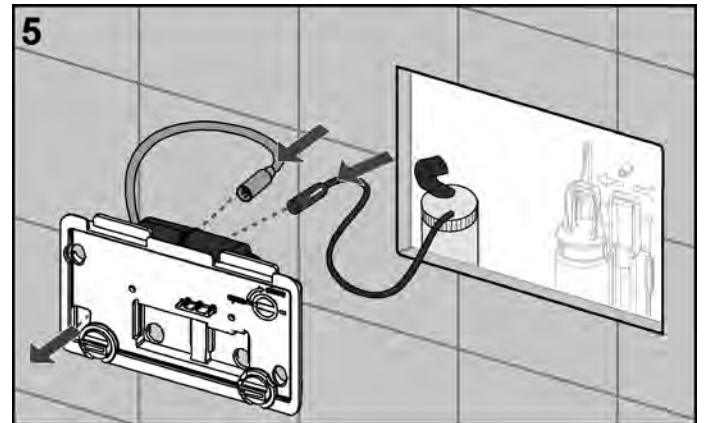

The cable of the actuating motor and battery is laid through the splash guard opening so that it is easier to connect in the next step.

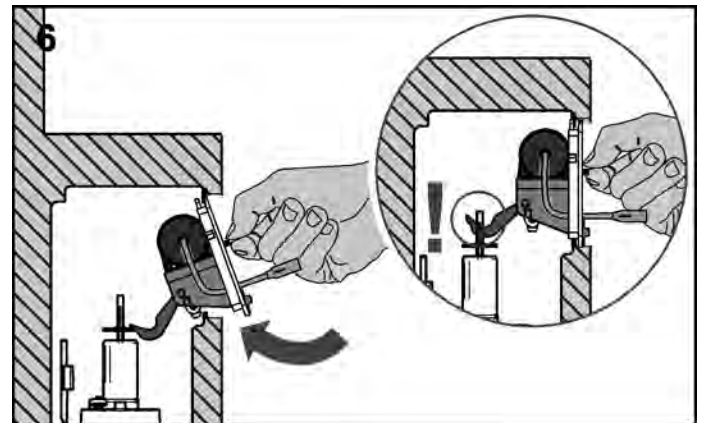

Insert the splash guard of the electronic device with actuating motor. The actuation hooks must sit correctly in the lug of the drain valve. Tighten the attaching screws of the splash guard.

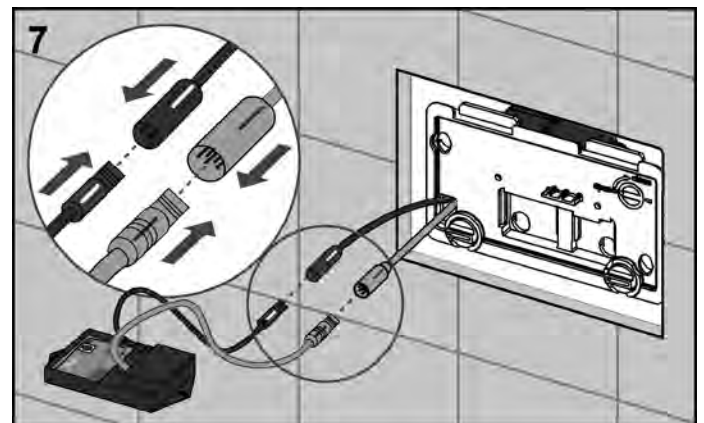

First connect the radio electronic device to the motor (grey connectors) and then to the batteries (black connectors). If installation is correct, the motor is actuated once to check this.

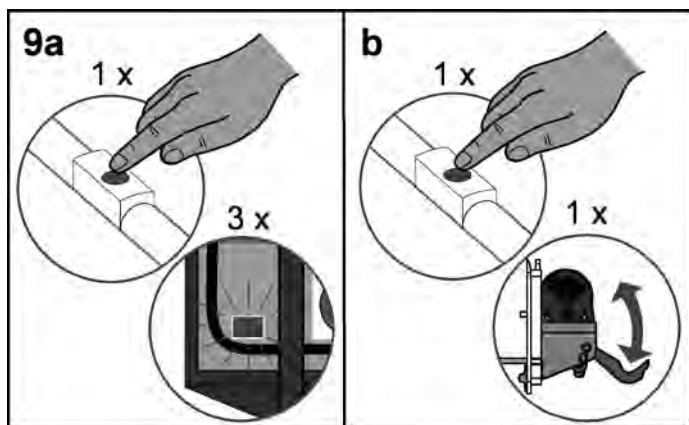
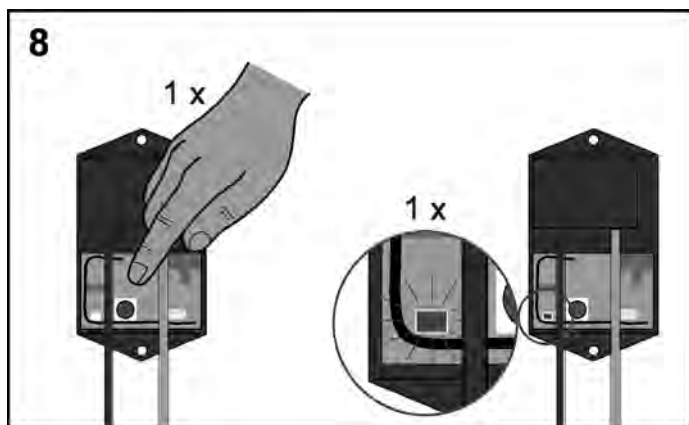

After the radio receiver has been installed correctly it must be adjusted to the signal of the button on the support arm. To do this, press the blue button on the receiver electronic device; the adjacent LED illuminates briefly once (figure 8). After this procedure, the receiver is ready-to-receive for one minute. In this space of time, the button on the safety support arm must be actuated once to establish the connection with the receiver electronic device. If connection is successful, the control LED of the receiver unit flashes three times after the button has been pressed. Now check the motor function. To do this, press the button again once and thus actuate the motor once.

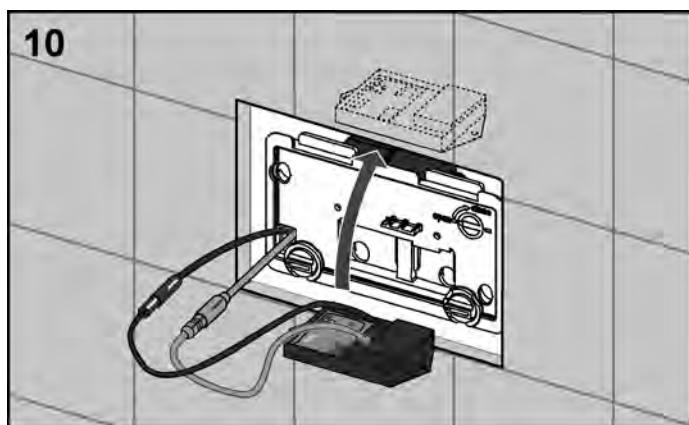

Place the electronic device on the cistern or in another suitable point in the wall. You can then install the push plate.

Toilet electronic device, radio actuation, 12 V mains

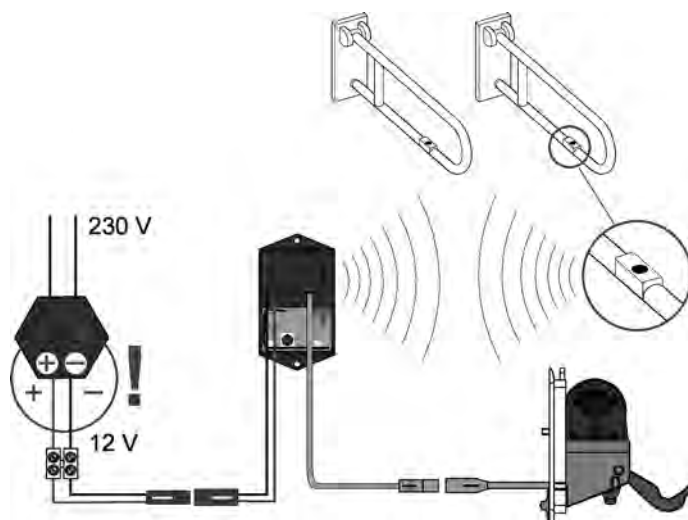

The radio pulse sent from the radio transmitter on actuation is received by a radio receiver. This receiver unit then switches the electric circuit for triggering the actuating motor.

To connect the 12 V mains version, the mains power must be transformed to 12 V direct current (transformer: order number 9 810 003, please order separately).

Installation of toilet electronic device, radio actuation, 12 V mains

To install the toilet electronic device with radio actuation, first follow the steps for the battery version: Open the splash guard, rinse the pipe thoroughly and adjust the drain valve (see also installation of toilet electronic device, radio actuation, 6 V battery).

With installation of this version, the later steps also differ depending on the toilet module installed: Either a TECE Geronto module with conduits for cable routing and installation box for holding the electronic device, or a different TECE module without conduits, is installed.

... Geronto module with conduits

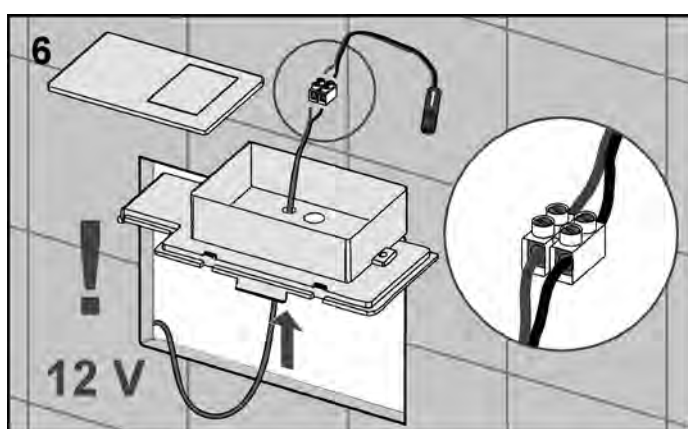
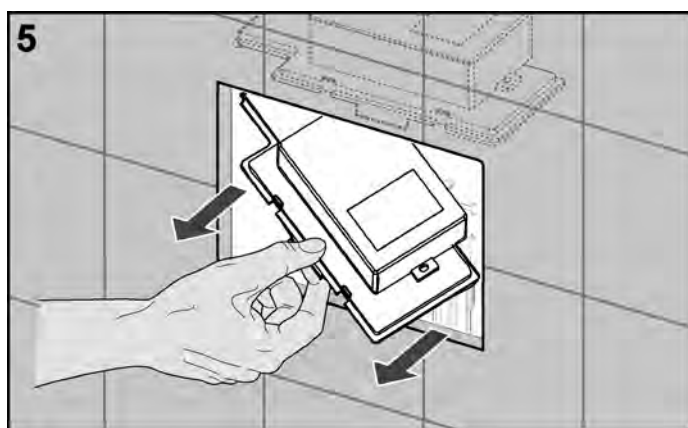

Open the lid of the cistern and remove it with the installation box. Guide the cable of the transformer (12 V) from below through the openings in the bottom of the box and connect it to the mains connection adapter (make sure the polarity is correct, see detail figure 6).

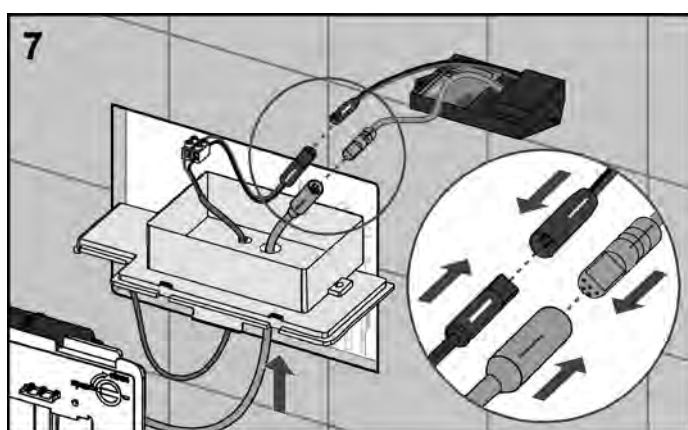

First connect the radio electronic device to the motor (grey connectors) and then to the batteries (black connectors). If installation is correct, the motor is actuated once to check this.

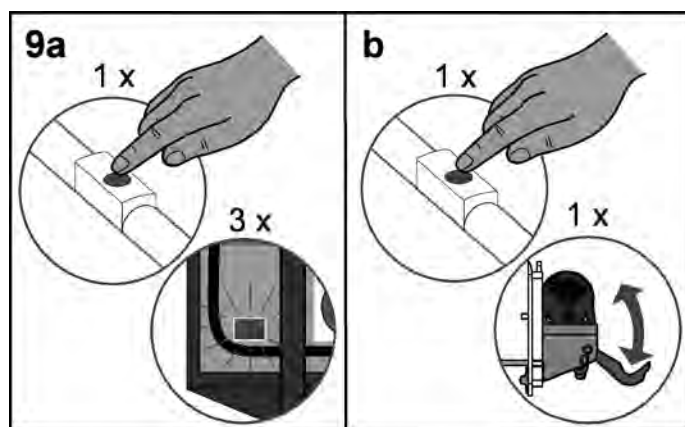
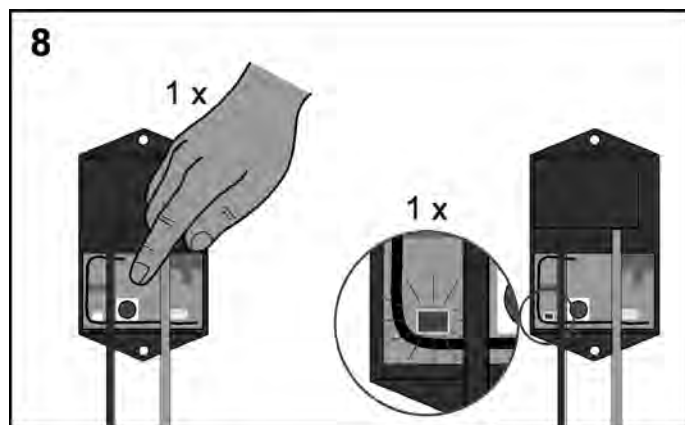

After the radio receiver has been installed correctly it must be adjusted to the signal of the button on the support arm. To do this, press the blue button on the receiver electronic device; the adjacent LED illuminates briefly once (figure 8). After this procedure, the receiver is ready-to-receive for one minute. In this space of time, the button on the safety support arm must be actuated once to establish the connection with the receiver electronic device. If connection is successful, the control LED of the receiver unit flashes three times after the button has been pressed.

Now check the motor function. To do this, press the button again once and thus actuate the motor once.

Push plates

TECE push plates – TECEplanus electronic devices, radio actuation

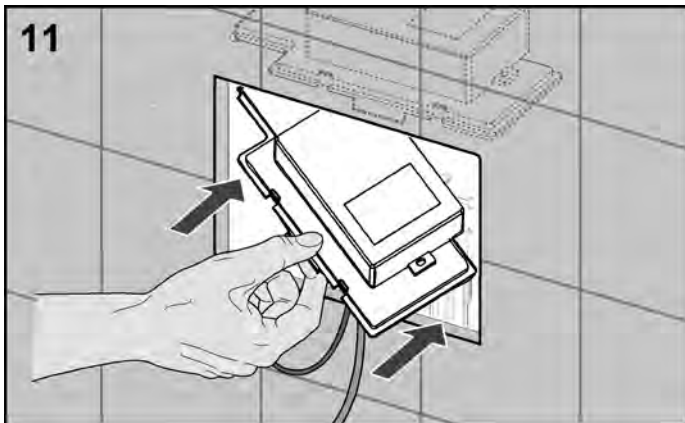
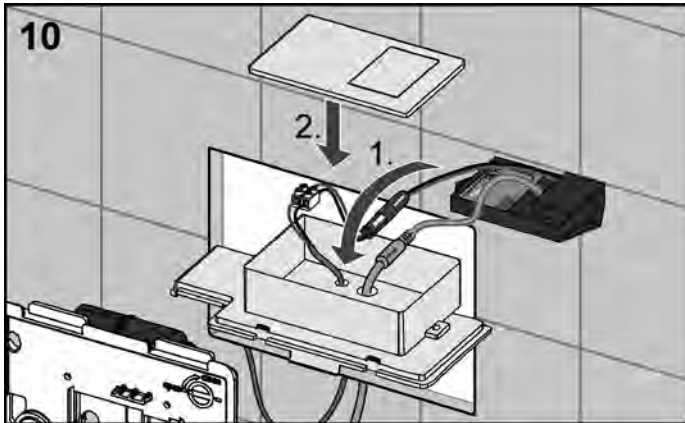

Place the electronic device in the installation box, close this, and install it in the cistern again.

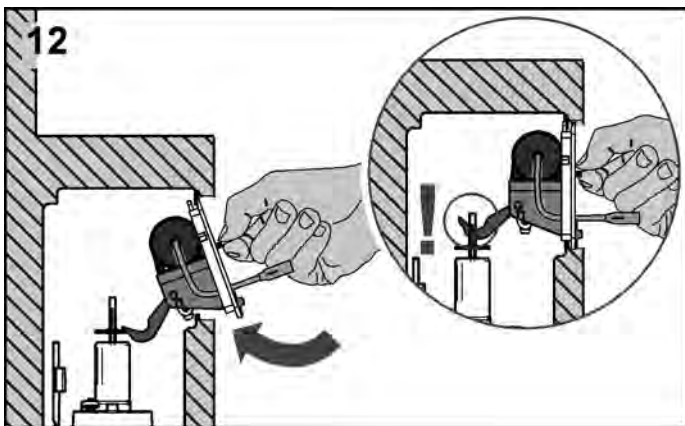

Insert the splash guard of the electronic device with actuating motor. The actuation hooks must sit correctly in the lug of the drain valve. Tighten the attaching screws of the splash guard.

You can then install the push plate.

... Toilet module (dry-wall and brick-wall construction) without conduits

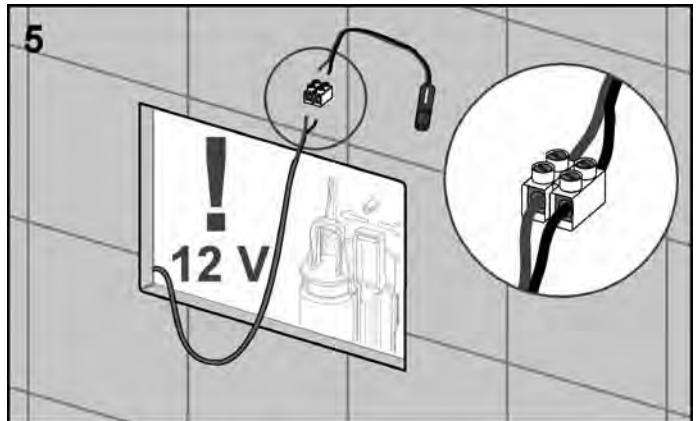

Connect the cable from the transformer to the network connection adapter (make sure the polarity is correct, see detail figure 5).

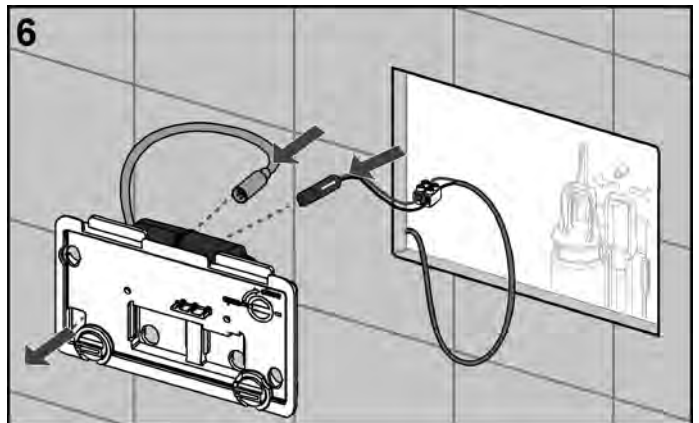

Guide the cables of the actuating motor and power connection through the opening bottom left in the splash guide.

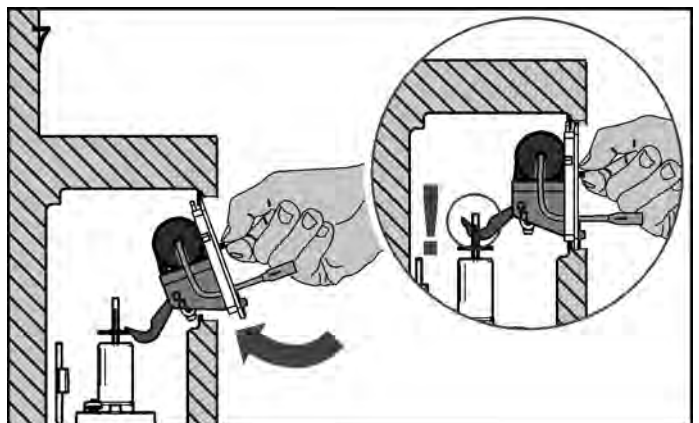

Install the splash guard with actuating motor. The actuation hooks must sit correctly in the lug of the drain valve. Tighten the attaching screws of the splash guard.

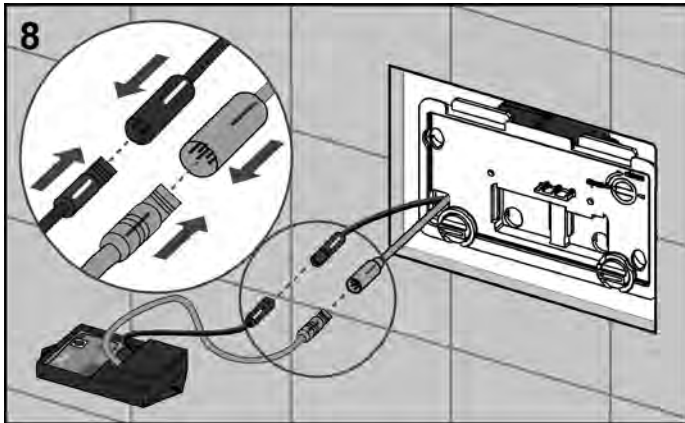

First connect the radio electronic device to the motor (grey connectors) and then to the batteries (black connectors). If installation is correct, the motor is actuated once to check this.

Now check the motor function. To do this, press the button again once and thus actuate the motor once.

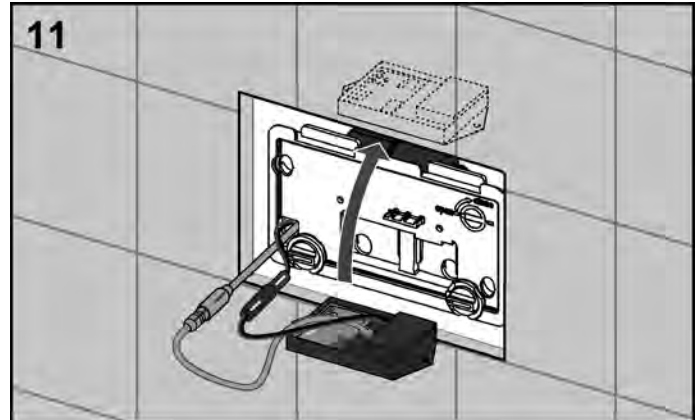

Place the electronic device on the cistern or in another suitable point in the wall. You can then install the push plate.

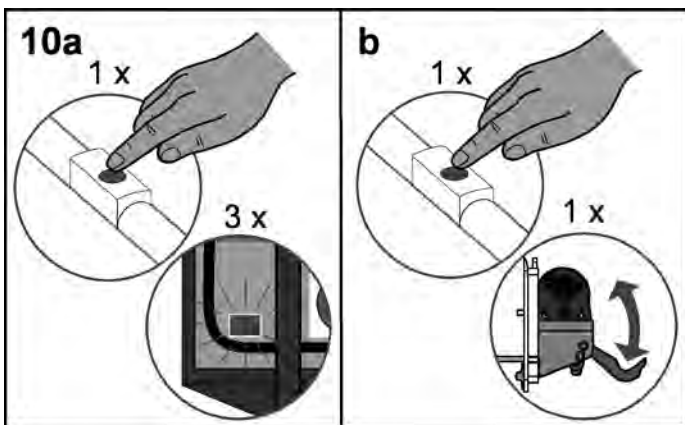
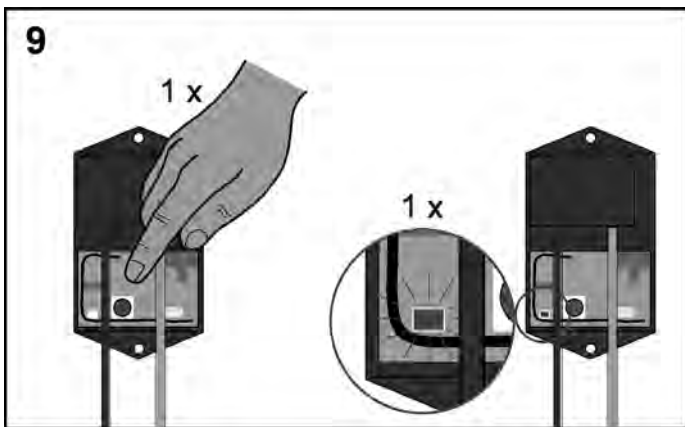

After the radio receiver has been installed correctly it must be adjusted to the signal of the button on the support arm. To do this, press the blue button on the receiver electronic device; the adjacent LED illuminates briefly once (figure 8). After this procedure, the receiver is ready-to-receive for one minute. In this space of time, the button on the safety support arm must be actuated once to establish the connection with the receiver electronic device. If connection is successful, the control LED of the receiver unit flashes three times after the button has been pressed.

TECE push plates – TECEplanus electronic devices, cable-connected actuation

TECEplanus electronic devices, cable-connected remote actuation

A further solution when safety support arms are used is the installation of a cable-connected version, in which a button connected by a cable is mounted on the safety support arm.

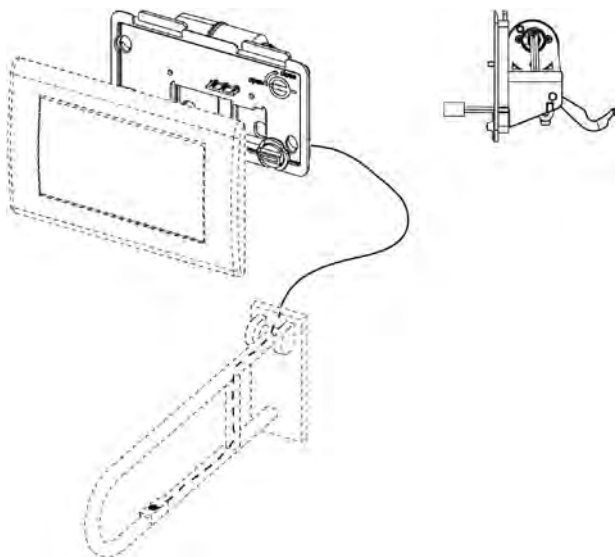

Energy options of the toilet electronic device for cable-connected remote actuation

- Mains version:
230 V alternating current is transformed to 12 V direct current by means of TECE transformer (order number 9 810 003, please order separately).
- Battery operation:
1 x lithium 2CR5 – 6 V (scope of delivery)

Based on a life of two years, the battery lasts for

- 20 000 flushes or
- approx. 27 flushes/day

Alternatively, you can have battery operation with 4 D cells (LR20). This increases the battery performance to 220,000 flushes, or 300 flushes/day. In addition to the batteries, you also require a different battery housing for this (order number 9 820 202).

NOTE:

A transformer must be used for power supply in the 12 V mains version. A suitable point (concealed socket or similar) must be planned in the bare-wall stage as this may under no circumstances be positioned directly on the push plate.

A push plate is not included in the delivery. With radio actuation, you can use any single-volume push plate; all dual-volume push plates are also possible (e.g. TECEloop, TECEsquare). However, only the large volume is flushed, even if both actuation rods are installed.

Toilet electronic device, cable-connected remote actuation, 6 V battery

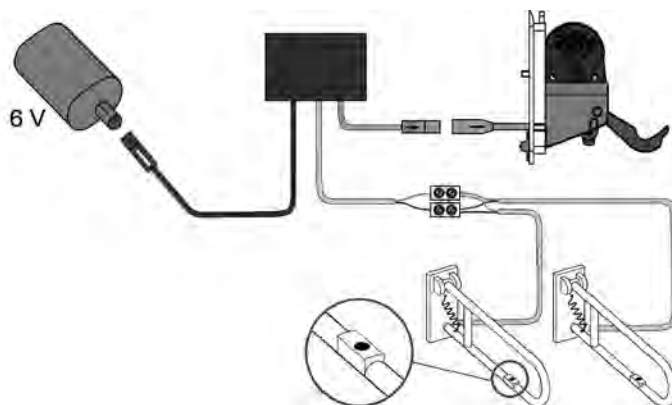

The flush is actuated when the circuit on the safety support arm button is closed. In addition to the electrical supply, the button on the safety support arm and the actuating motor, an electronic component must also be incorporated between the various components. Power is supplied by a 6 V battery.

Installation of toilet electronic device, cable-connected remote actuation, 6 V battery

To install the toilet electronic device with cable-connected remote actuation, first follow the steps for the battery version:

Open the splash guard, rinse the pipe thoroughly and adjust the drain valve (see also installation of toilet electronic device, radio actuation, 6 V battery).

The next steps differ depending on the toilet module used: Either a TECE Geronto module with conduits for cable routing and installation box for holding the electronic device, or a different TECE module without conduits, is installed.

... Geronto module with conduits

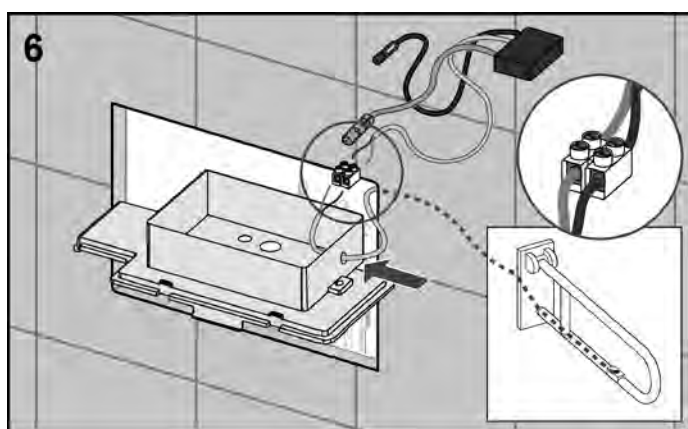
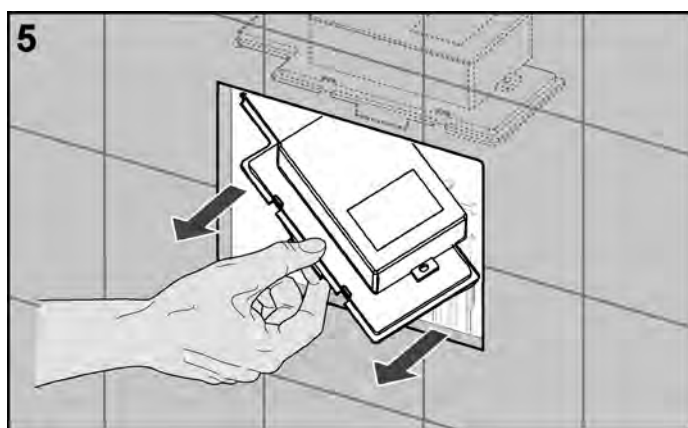

Open the lid of the cistern and remove it with the installation box. Guide the cable from the button on the safety support arm from the side into the box and connect it to the electronic device (lustre terminal - make sure polarity is correct).

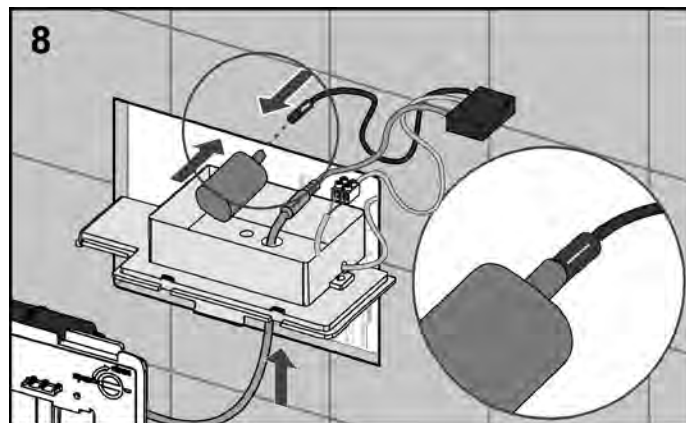
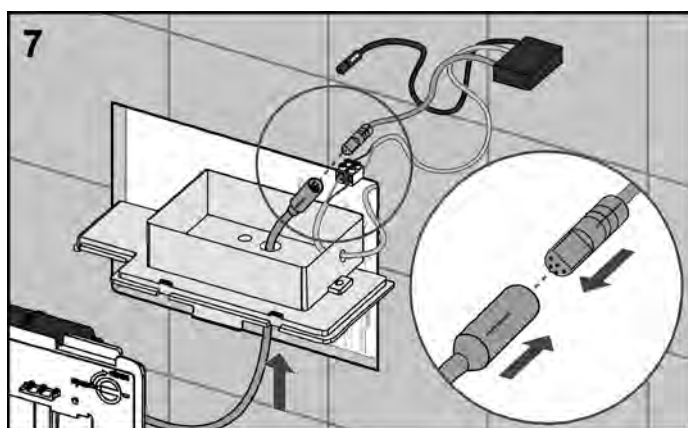

First connect the electronic device to the motor (black connectors) and only then to the battery (grey connectors). If installation is correct, the motor is actuated once for checking purposes.

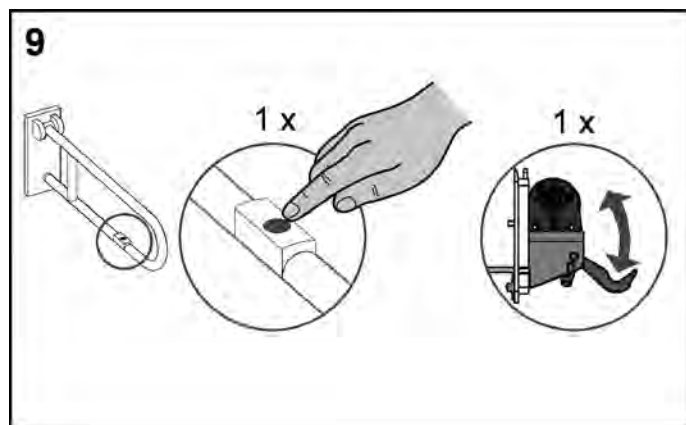

Now check correct functioning. To do this, press the button once and actuate the motor (once).

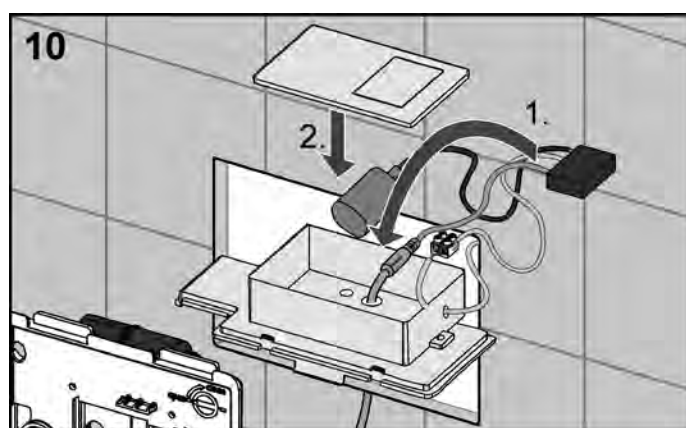

Push plates

TECE push plates – TECEplanus electronic devices, cable-connected actuation

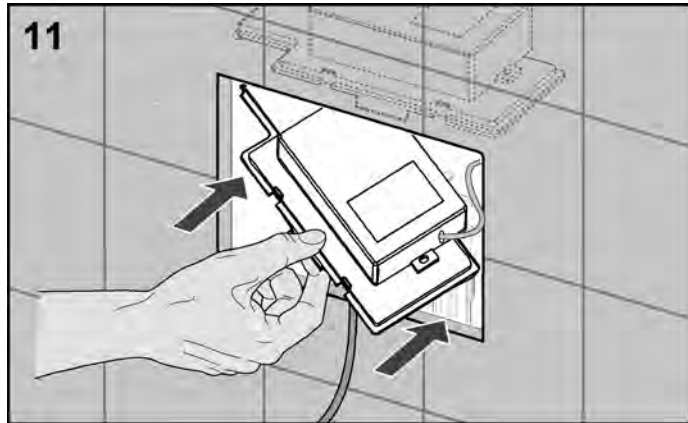

11 Place the electronic device and battery in the installation box, close this, and install it in the cistern again.

... Toilet module (dry-wall and brick-wall construction) without conduits

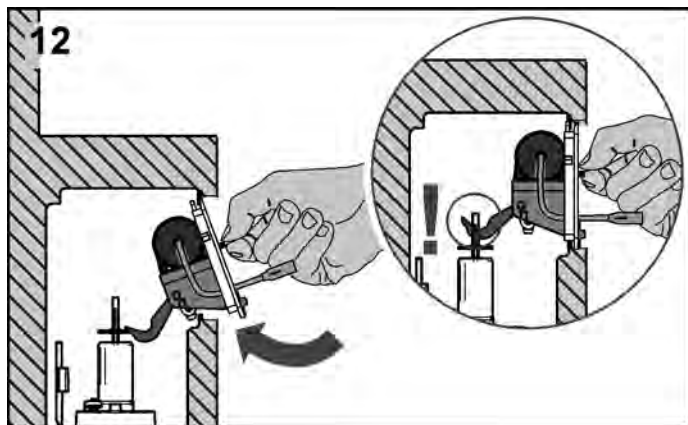
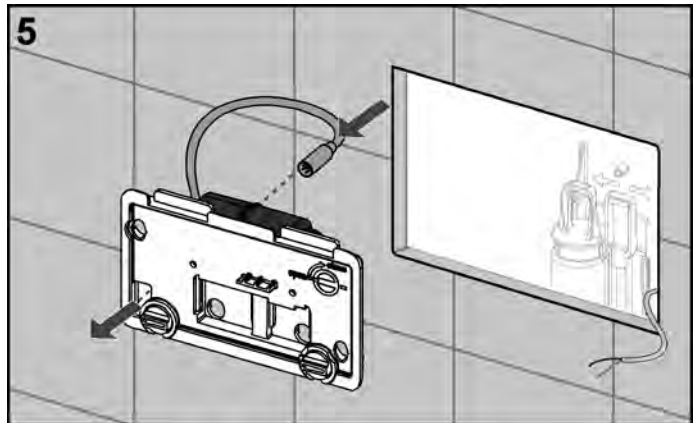

12 Insert the splash guard of the electronic device with actuating motor. The actuation hooks must sit correctly in the lug of the drain valve. Tighten the attaching screws of the splash guard.

You can then install the push plate.

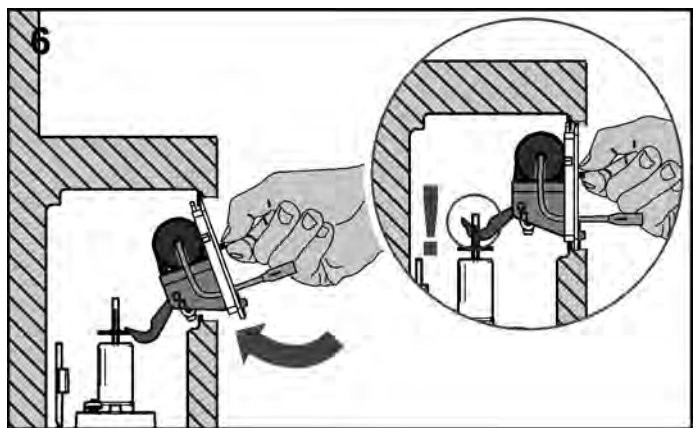

6 Guide the cable of the actuating motor through the opening in the splash guard.

Then insert the splash guard of the electronic device with actuating motor. The actuation hooks must sit correctly in the lug of the drain valve. Tighten the attaching screws of the splash guard.

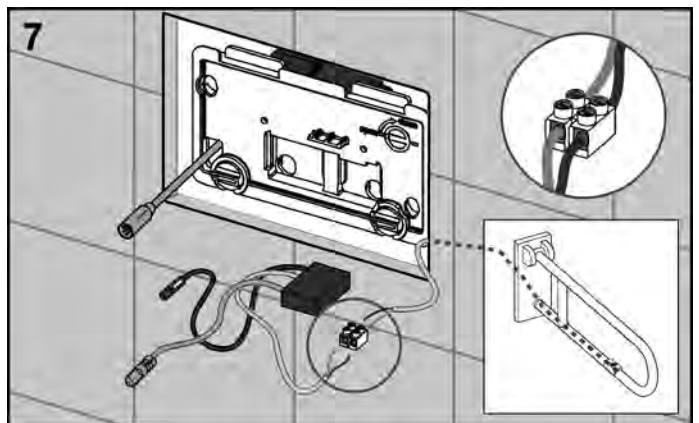

7 Connect the cable from the button on the safety support arm with the electronic device (lustre terminal). Make sure the polarity is correct.

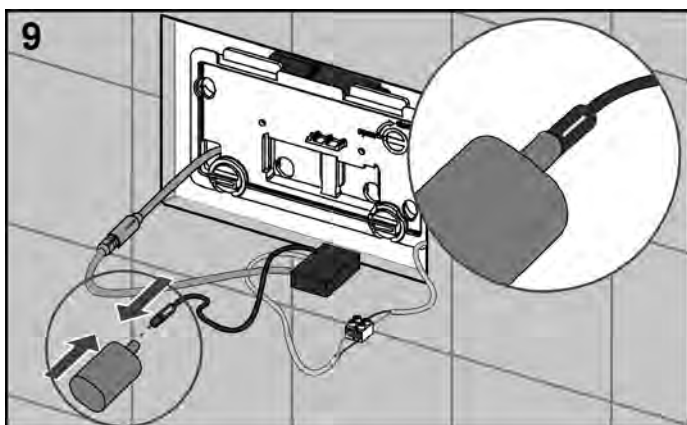
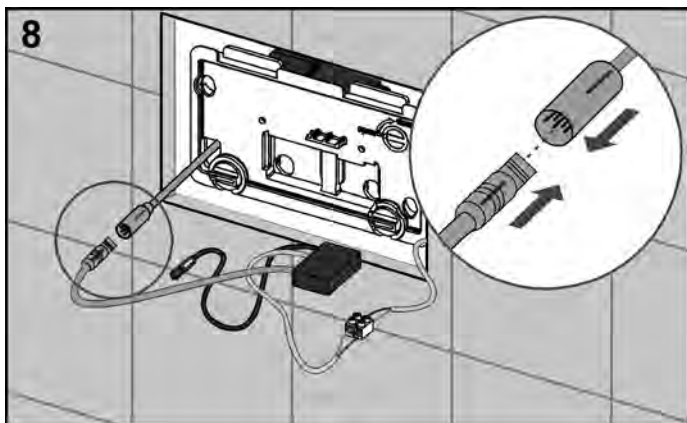

Then connect the electronic device first to the motor (grey connectors) and then to the batteries (black connectors). If installation is correct, the motor is actuated once to check this.

Now check the electronic device function. To do this, press the button once and actuate the motor (once).

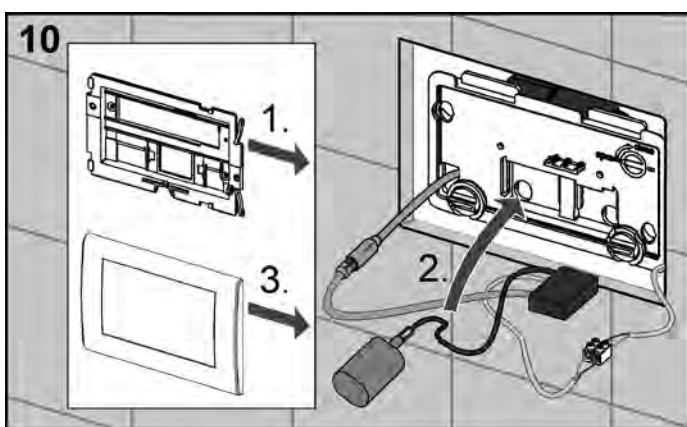

Mount the attaching frame of the push plate and place the electronic device and battery at a suitable point (e.g. between the attaching frame and push plate). You can then install the push plate.

Toilet electronic device, cable-connected remote actuation, 12 V mains

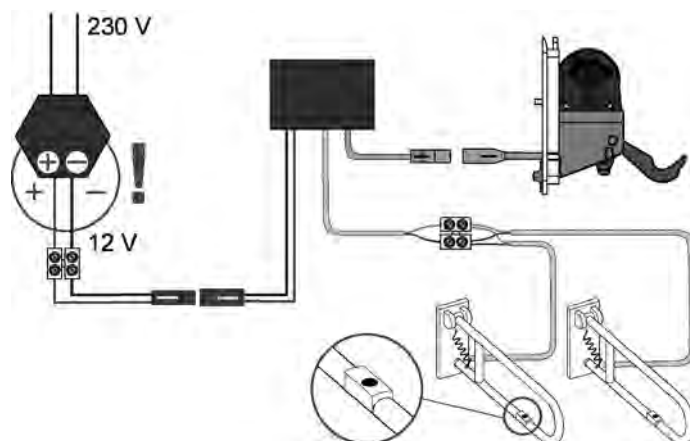

The flush is actuated when the circuit on the safety support arm button is closed. In addition to the electrical supply, the button on the safety support arm and the actuating motor, an electronic component must also be incorporated between the various components.

To connect the 12 V mains version, the mains power must be transformed to 12 V direct current (transformer: order number 9 810 003, please order separately).

Installation of toilet electronic device, cable-connected remote actuation, 12 V mains

When installing the toilet electronic device with cable-connected remote actuation, the initial steps are the same as for the electronic device with radio actuation: Open the splash guard, rinse the pipe thoroughly and adjust the drain valve (see also installation of toilet electronic device, radio actuation, 6 V battery).

The next steps differ depending on the toilet module used: Either a TECE Geronto module with conduits for cable routing and installation box for holding the electronic device, or a different TECE module without conduits, is installed.

TECE push plates – TECEplanus electronic devices, cable-connected actuation

... Geronto module with conduits

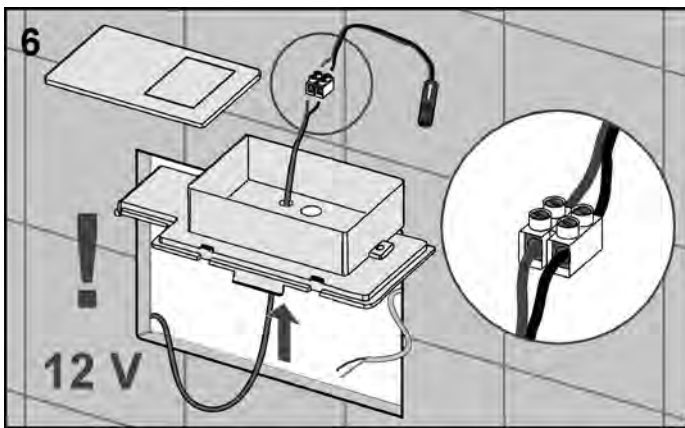
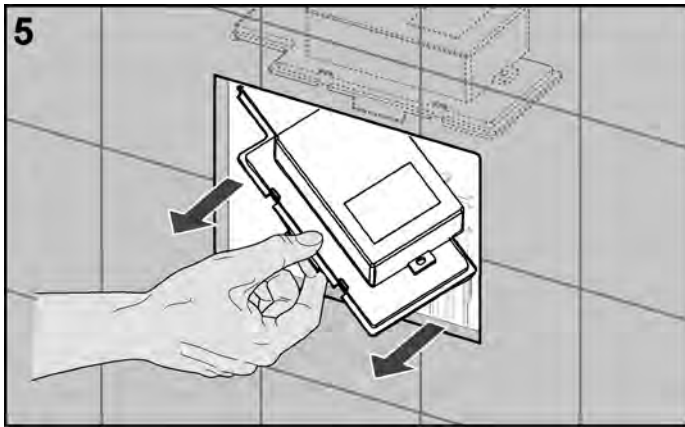

Open the lid of the cistern and remove it with the installation box. Guide the cable from the transformer through the opening in the bottom and connect it to the network connection adapter (make sure the polarity is correct, see detail figure 6).

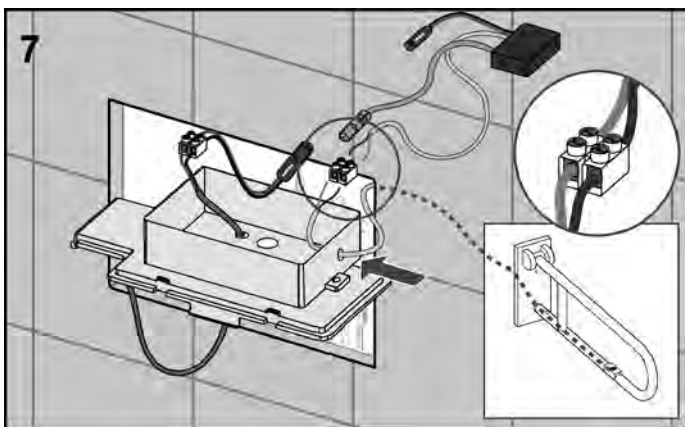

Guide the cable from the button on the safety support arm from the side into the box and connect it to the electronic device (lustre terminal). Make sure the polarity is correct.

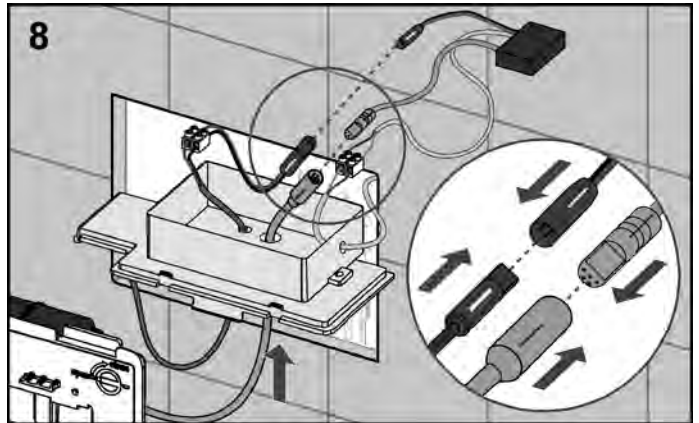

Now connect the electronic device first to the motor (grey connectors) and then to the power supply (black connectors). If installation is correct, the motor is actuated once to check this.

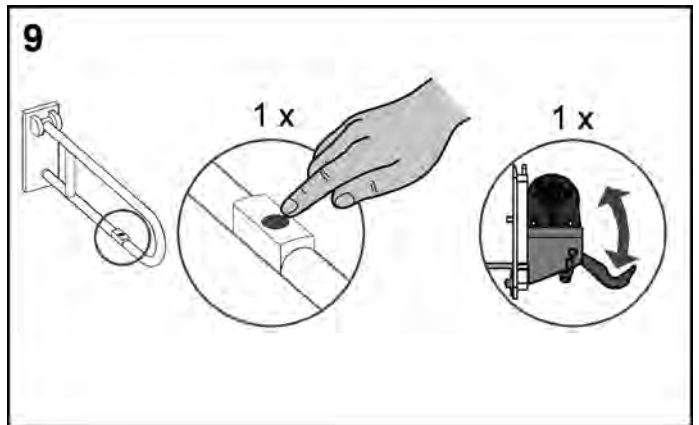

Now check the electronic device function: First press the button again once and thus actuate the motor (once).

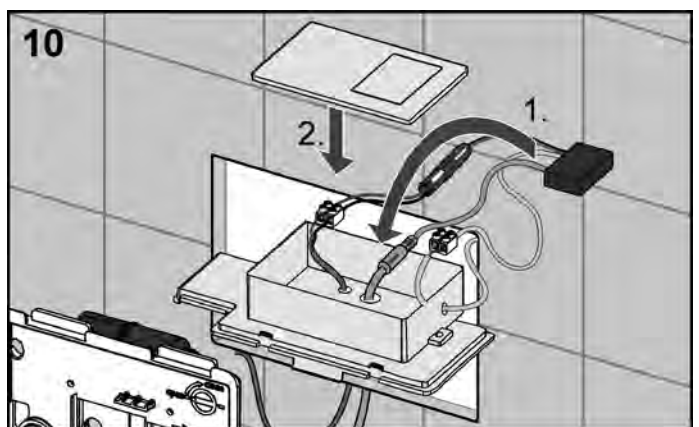

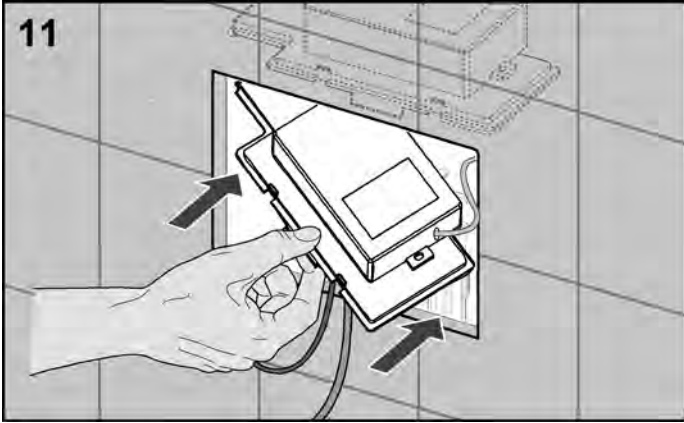

11 Place the electronic device in the installation box, close this, and install it in the cistern again.

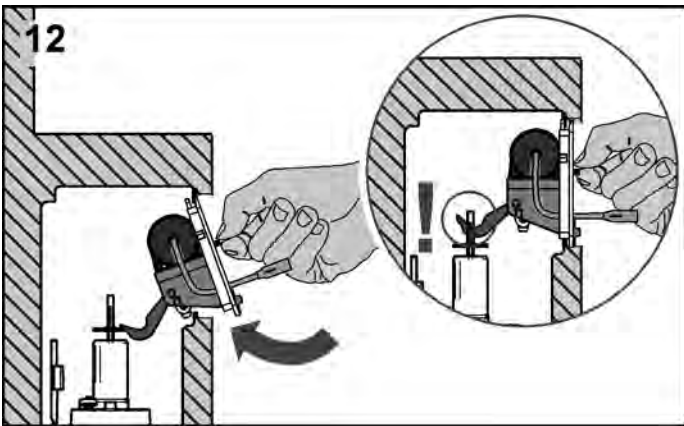

12 Insert the splash guard of the electronic device with actuating motor. The actuation hooks must sit correctly in the lug of the drain valve. Tighten the attaching screws of the splash guard.

You can then install the push plate.

... Toilet module (dry-wall and brick-wall construction) without conduits

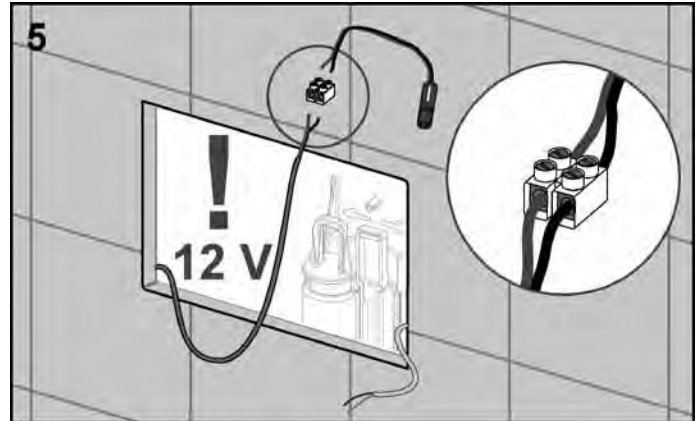

5 Connect the cable from the transformer to the network connection adapter (make sure the polarity is correct, see detail figure 5).

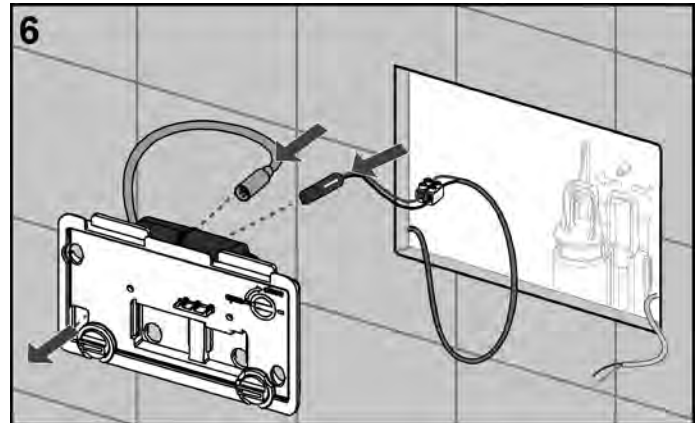

6 Guide the cables of the actuating motor and power connection through the opening bottom left in the splash guide.

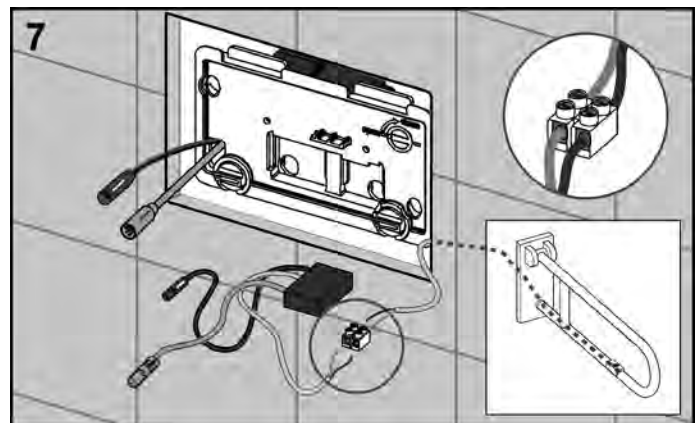

7 Install the splash guard with actuating motor. The actuation hooks must sit correctly in the lug of the drain valve. Tighten the attaching screws of the splash guard. Connect the cable from the button on the safety support arm to the electronic device (lustre terminal). Make sure the polarity is correct.

TECE push plates – TECEplanus electronic devices, cable-connected actuation

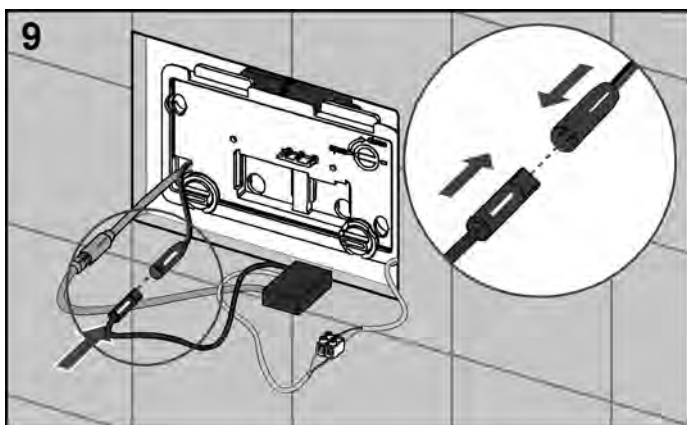
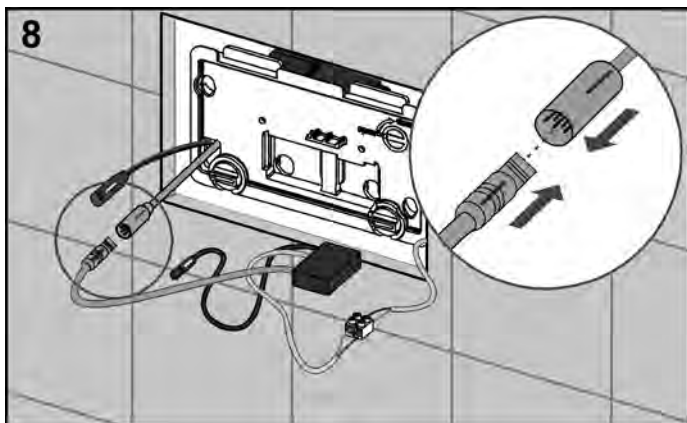

Then connect the electronic device to the motor (grey connectors) and then to the batteries (black connectors). If installation is correct, the motor is actuated once to check this.

Now check the electronic device function: First press the button again once and thus actuate the motor (once).

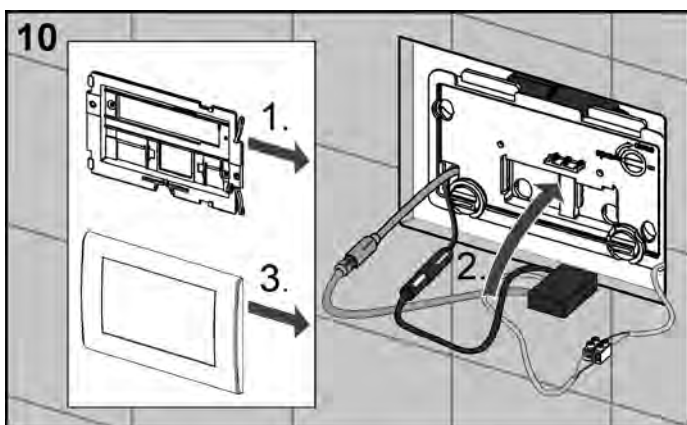

Mount the attaching frame of the push plate and place the electronic device at a suitable point (e.g. between the attaching frame and push plate). You can then install the push plate.

TECEloop

The TECEloop push plates are available in plastic or with a glass surface. The special feature of the glass TECEloop push plate is the option of flush-mounted installation. The TECEloop push plate is also available for the urinal.

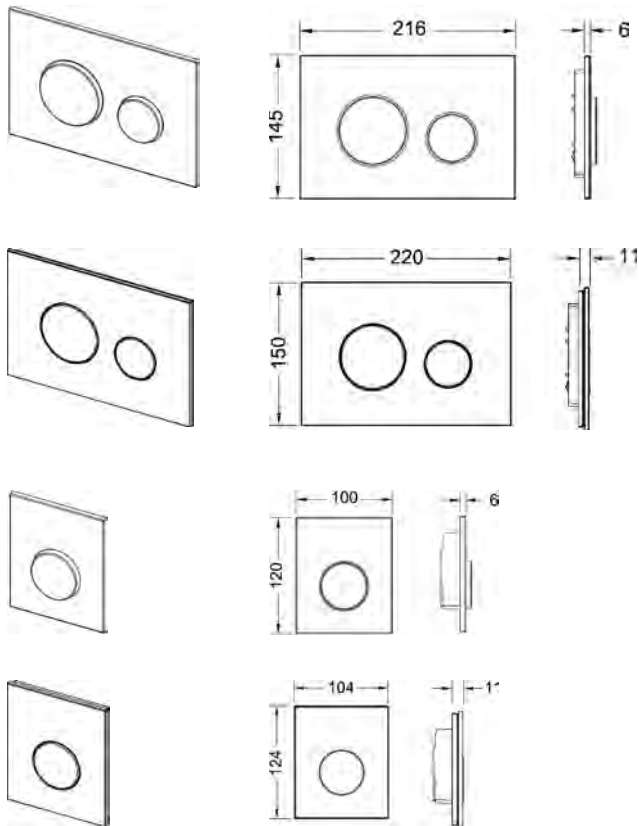

TECEloop toilet push plate, plastic
 TECEloop toilet push plate, glass
 TECEloop urinal push plate, plastic
 TECEloop urinal push plate, glass

Installation of plastic toilet push plate, surface-mounted

As with all TECE push plates the first four installation steps are the same for all toilet push plates (see section "TECEbase, toilet push plate installation").

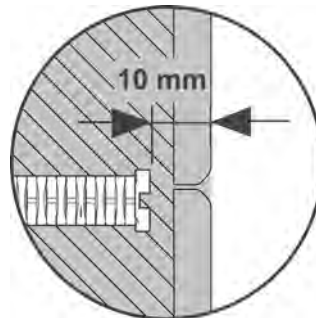
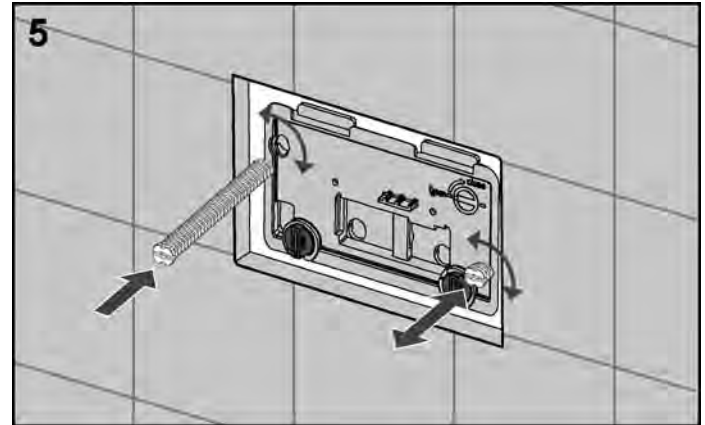

Screw in both attaching rods, and set the distance between the attaching rod and the wall surface to 10 mm.

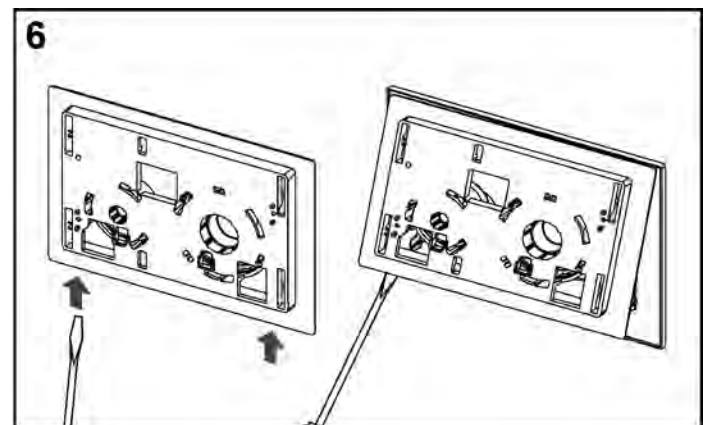

For the plastic TECEloop push plate only: Cover and actuation unit are supplied assembled and must be separated for installation. Use a screwdriver to detach the cover from the actuation unit. Insert the screwdriver in the recesses on the bottom side of the push plate and separate carefully.

TECE push plates – TECEloop

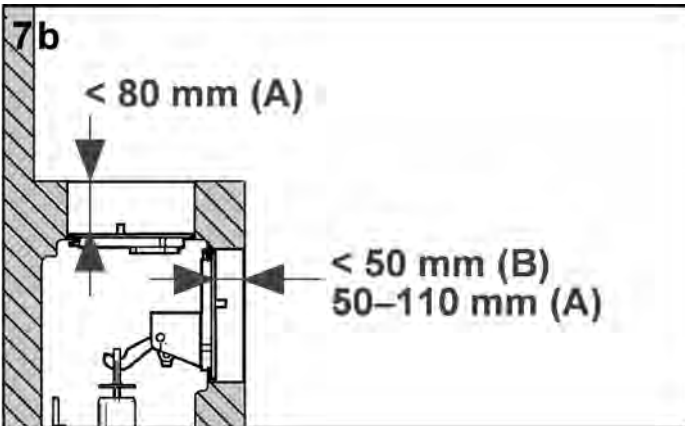
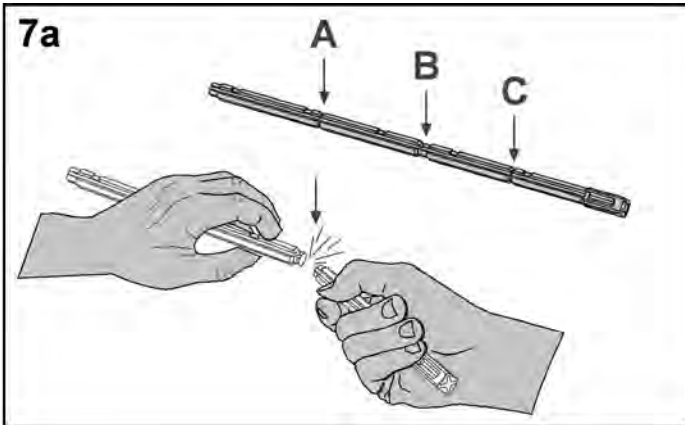

Snap off the actuation rods in accordance with the wall thickness.

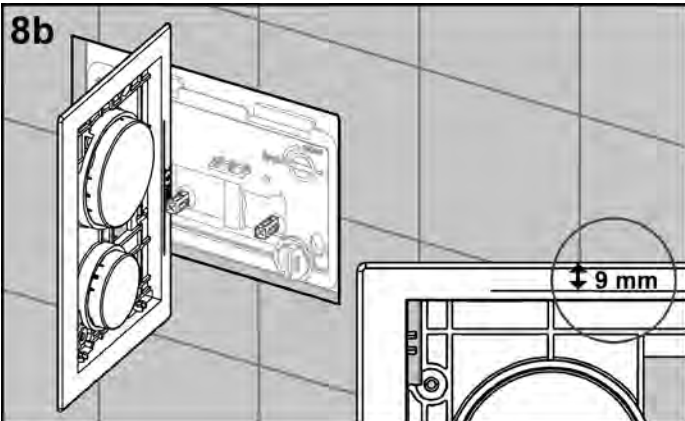
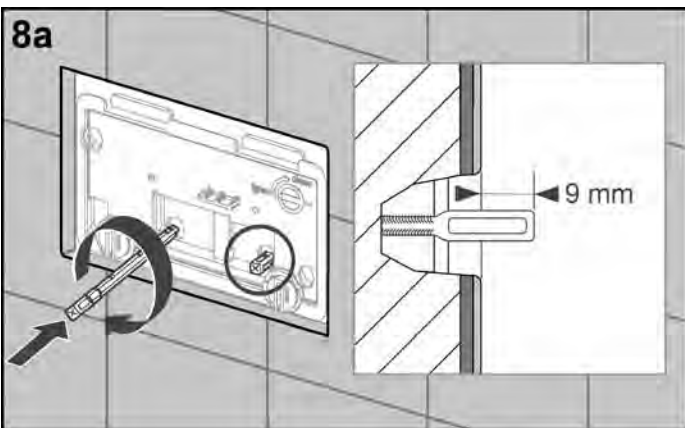

Screw in the actuation rods, set the distance to the front edge of the attaching frame to 9 mm. The length for the actuation rod is marked on the upper side of the actuation

unit. As a result, you can set this quickly and easily.

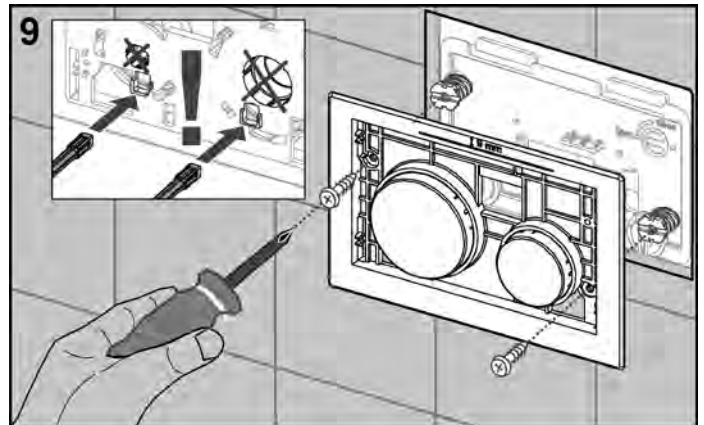

Screw the attaching frame onto the attaching rods.

NOTE:

During installation, it is essential for the actuation rods to be inserted in the rectangular slots on the push plate, not centrally in the round buttons.

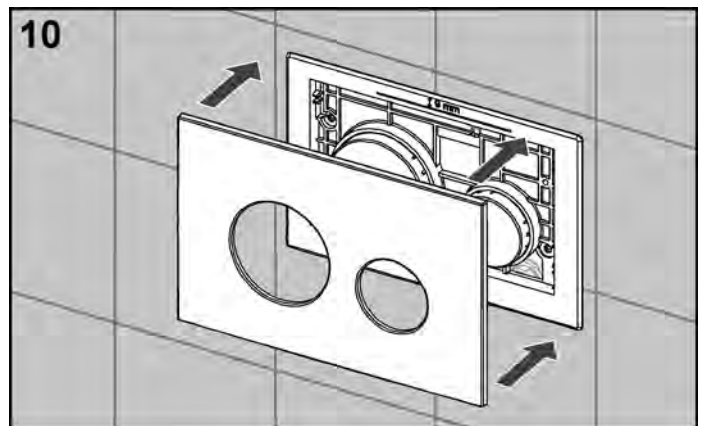

Snap the cover of the TECEloop push plate into the attaching frame.

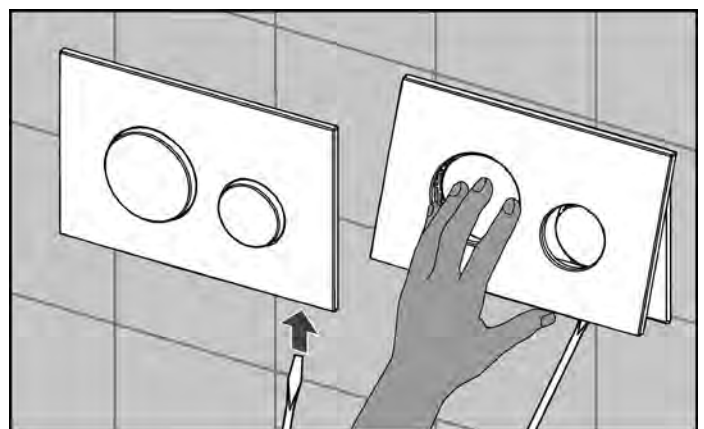

Use a screwdriver to detach the installed cover from the actuation unit. Insert the tool in the recesses on the bottom side of the push plate and remove it carefully.

TECEloop modular system.

The module system is available for the TECEloop toilet push plate with glass cover. Glass cover and actuation unit must be ordered separately. This ensures a large number of colour combinations (104 in total).

Push buttons + cover = toilet push plate

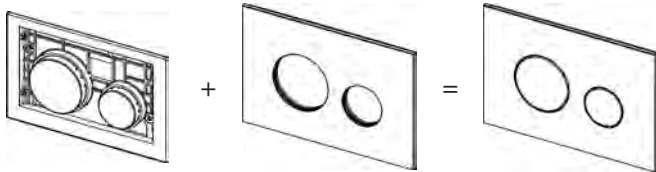

The basic idea of the TECEloop modular system is to match the push plate to the other colours in the bathroom as effectively as possible. For this reason, some of the glass covers coordinate with the colours used by Alape or Burgbad.

Installation of glass toilet push plate, surface-mounted

The surface-mounted installation of the TECEloop push plates with a plastic or glass cover is largely identical (see section "TECEloop – installation of plastic toilet push plate, surface-mounted"). All that is different is that the cover does not have to be removed, because the parts are not delivered assembled.

Installation of glass toilet push plate, flush-mounted

The use of an installation frame is essential for the flush-mounted installation of TECEloop glass. The installation frame must be installed before fine installation takes place (see section "Flush-mounted installation").

As with all TECE push plates the first four installation steps are the same for all toilet push plates (see section "TECEbase, toilet push plate installation").

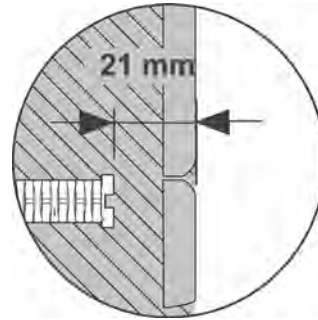
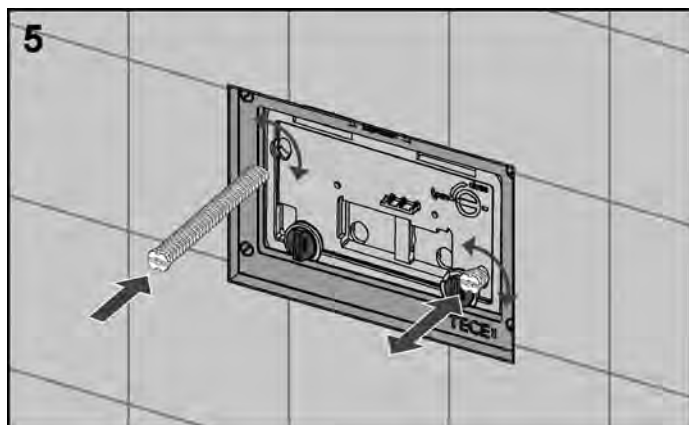

Screw in both attaching rods, and set the distance between the attaching rod and the wall surface to 21 mm.

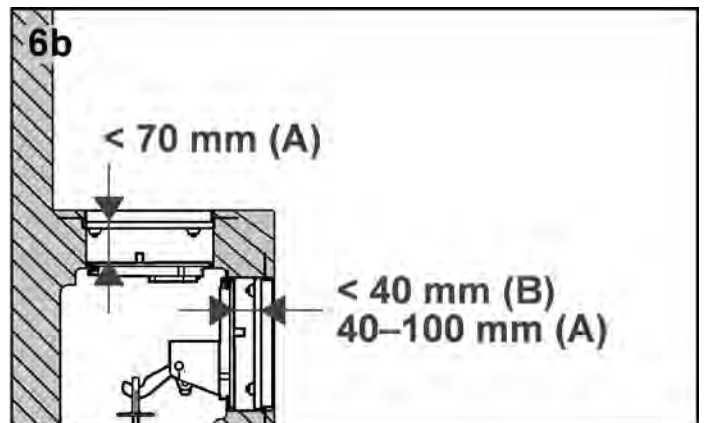
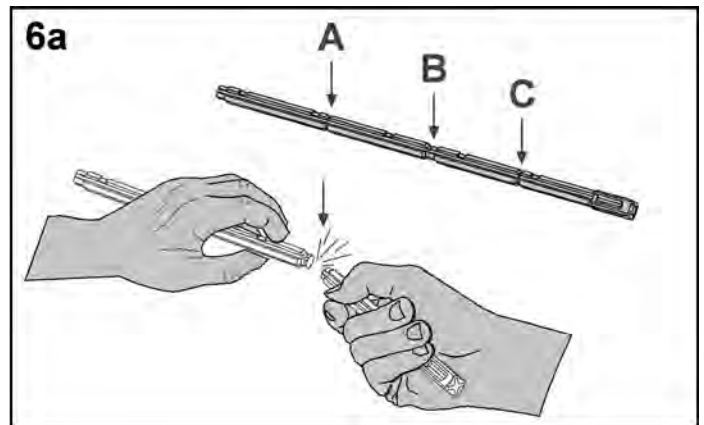

Snap off the actuation rods in accordance with the wall thickness.

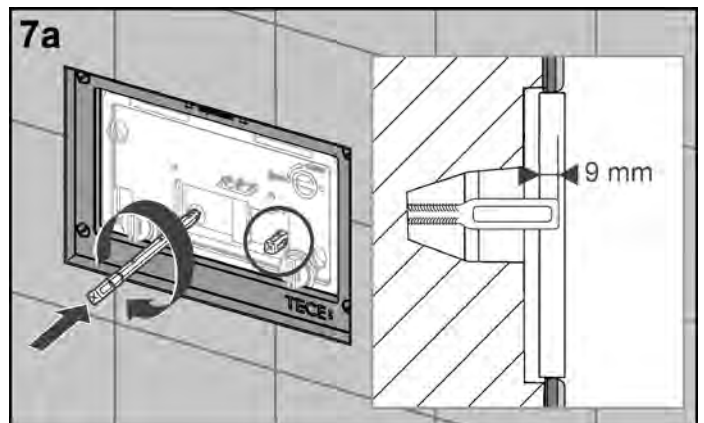

TECE push plates – TECEloop

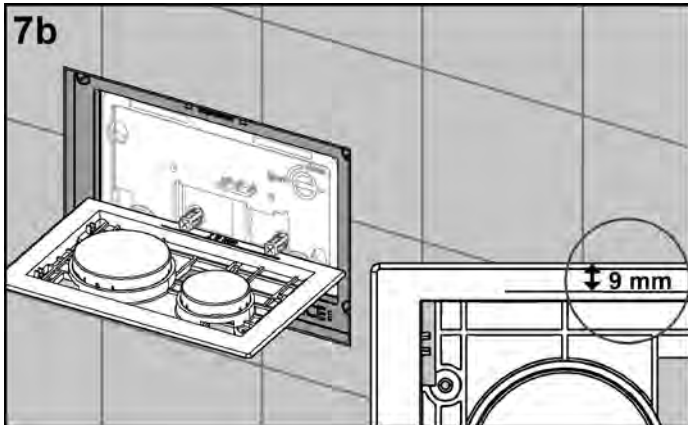

Screw in the actuation rods, set the distance to the front edge of the inner frame to 9 mm. The length for the actuation rod is marked on the upper side of the actuation unit. As a result, you can set this quickly and easily.

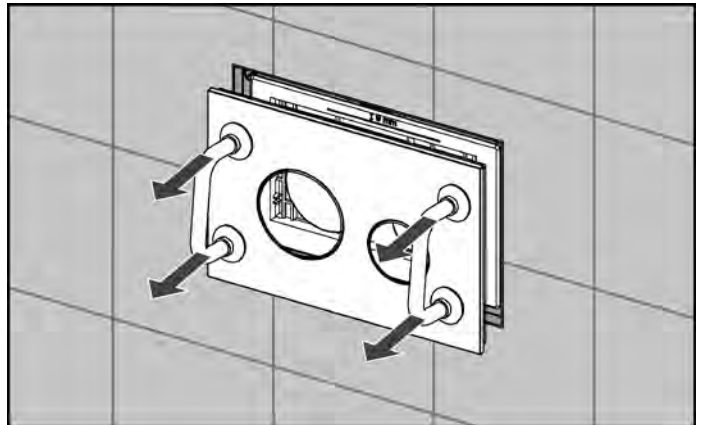

The installed cover can be removed from the actuation unit using the bow-type handles contained in the installation frame delivery. Position the suction cups only on the cover to be removed.

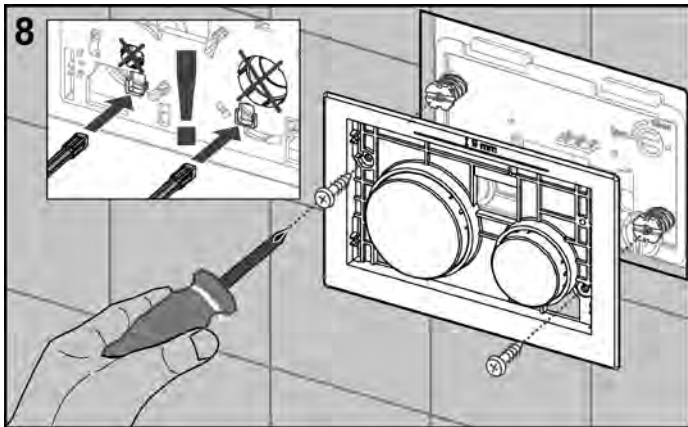

Screw the attaching frame onto the attaching rods.

NOTE:

During installation, it is essential for the actuation rods to be inserted in the rectangular slots on the push plate, not centrally in the round buttons.

Installation of plastic urinal push plate, surface-mounted

The first steps in the procedure for installing the urinal push plates are the same for all TECE push plates (surface-mounted) – see "TECEambia - urinal push plate installation"

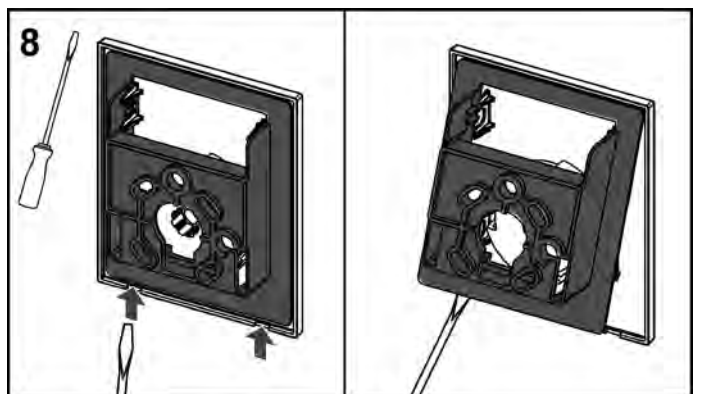

Use a screwdriver to remove the attaching frame from the cover. Use the notches intended for this on the bottom side.

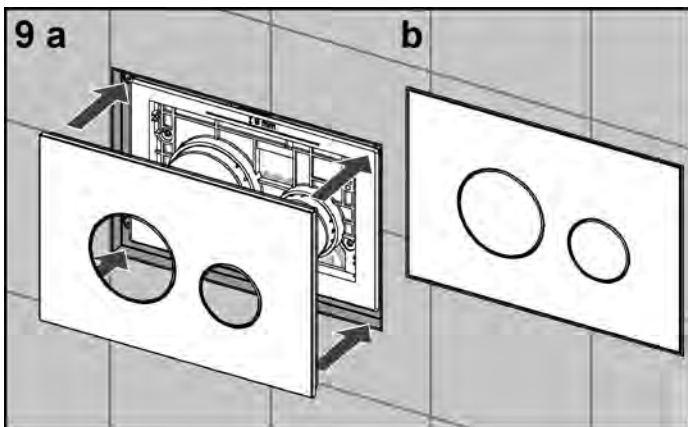

Snap the cover of the TECEloop push plate into the attaching frame.

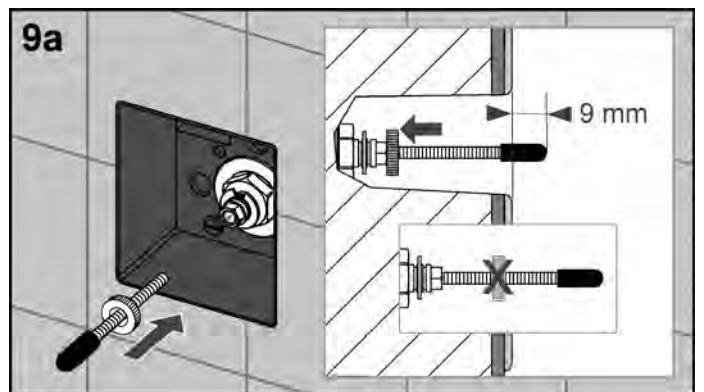

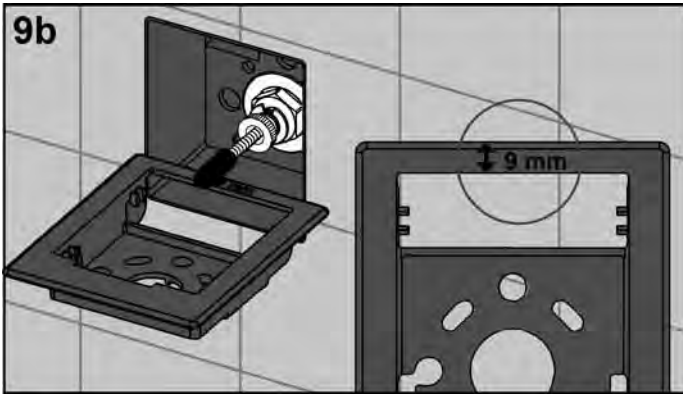

Screw the actuation rod in as far as specified (for TECEloop 9 mm distance to wall surface) and secure it against twisting with the lock nut. The length for the actuation rod is marked on the upper side of the attaching frame. As a result, you can set this quickly and easily.

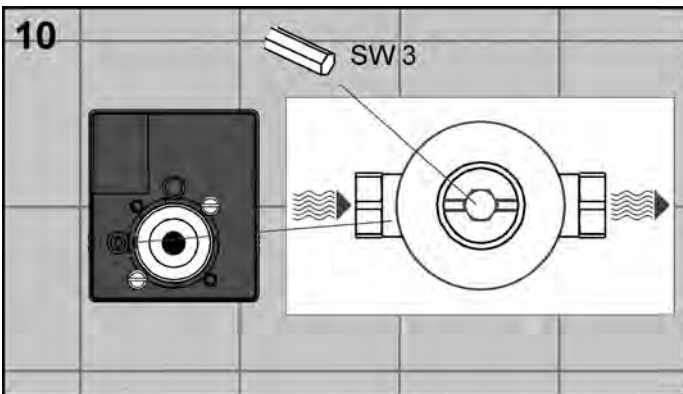

Open the inlet flow control.

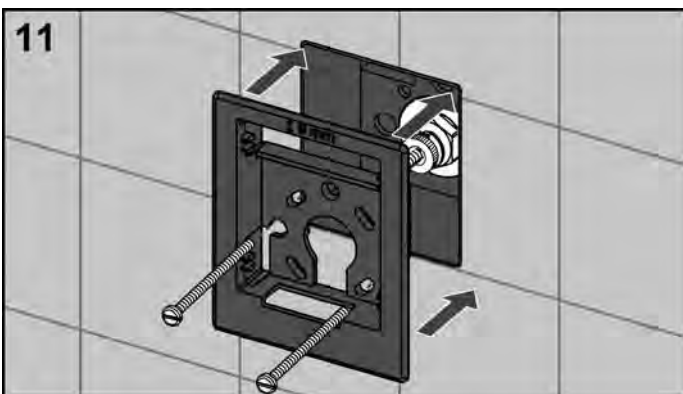

Screw the attaching frame to the urinal flush valve housing.

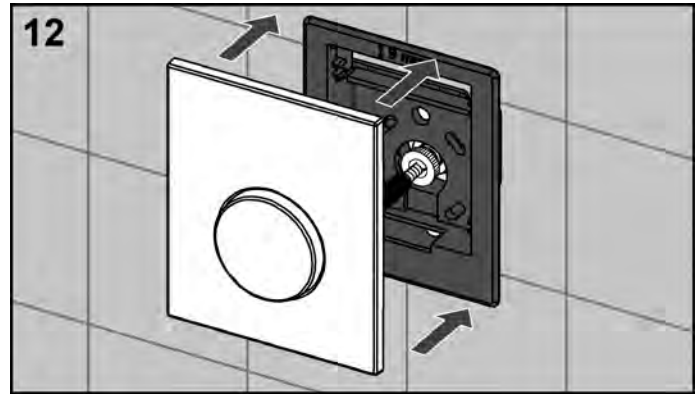

Finally, install the push plate cover.

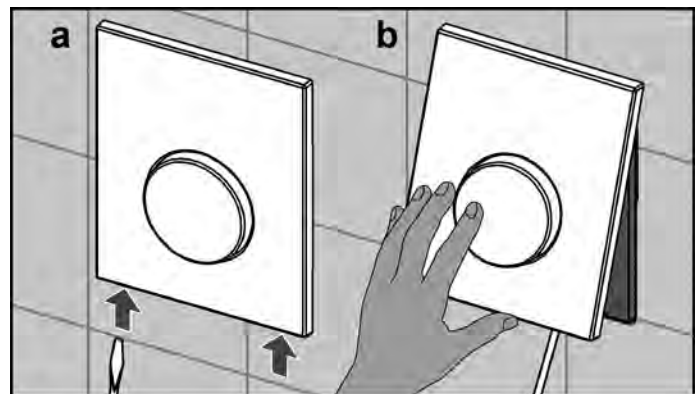
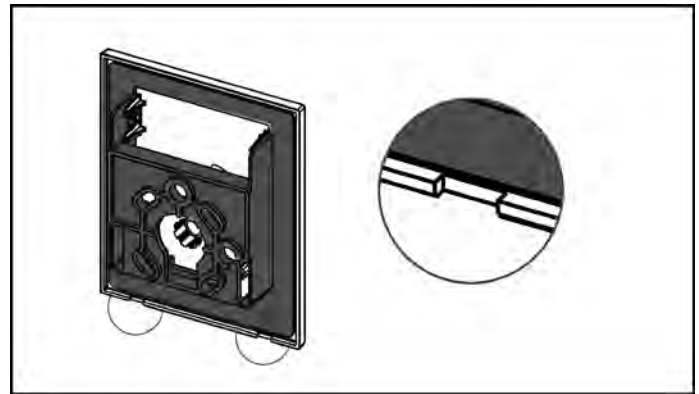

For removal, the bottom side of the push plate has notches for a screwdriver.

Installation of glass urinal push plate, surface-mounted

The surface-mounted installation of the TECEloop urinal push plates with a plastic or glass cover is largely identical (see section "TECEloop – installation of plastic urinal push plate, surface-mounted").

Installation of glass urinal push plate, flush-mounted

The following steps are carried out to install a flush-mounted urinal push plate:

TECE push plates – TECEloop

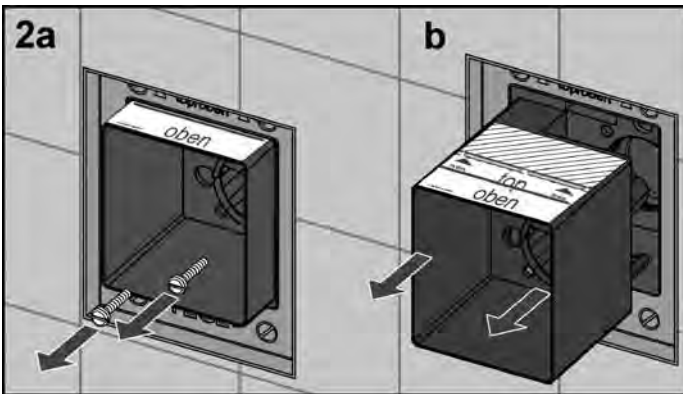
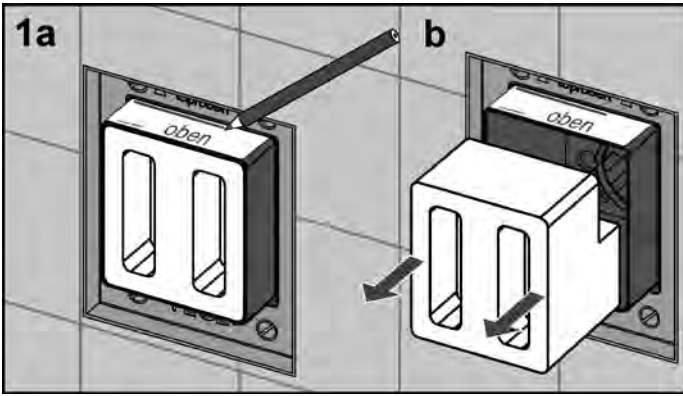

First mark the projection of the bare-wall protection and remove the polystyrene support. Loosen the screws and take out the bare-wall protection.

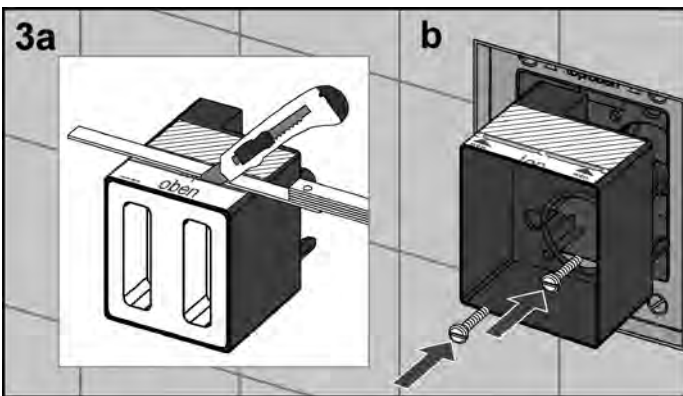

Insert the polystyrene support again for stabilization and cut the bare-wall protection along the marking. Insert the bare-wall protection again and screw it onto the flush valve housing

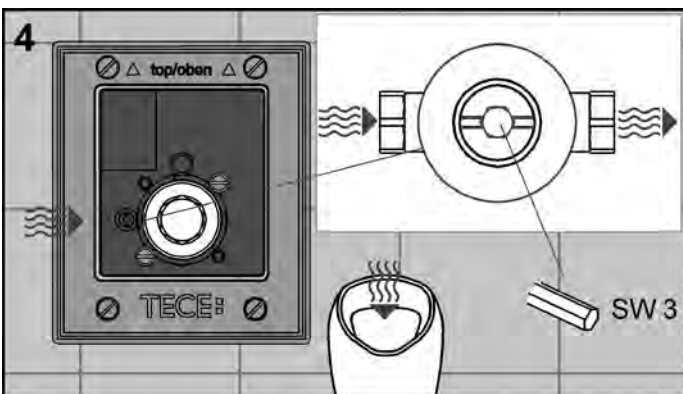

Rinse the pipe.

NOTE:

In the pressure test, the inlet flow control of the flush valve must be set to through flow.

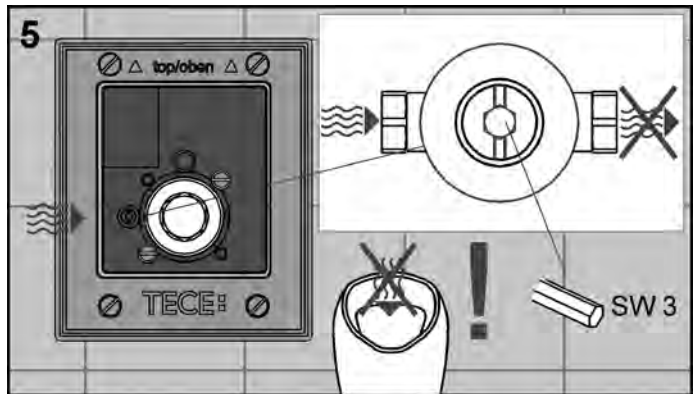

Before installing the cartridge, make sure that the inlet flow control is closed, so that no water escapes during installation. Close the flow control using a hexagonal wrench. In through-flow setting (figure 4), the groove of the flow control runs parallel to the housing, when the setting is closed (figure 5), it is at right angles to the housing.

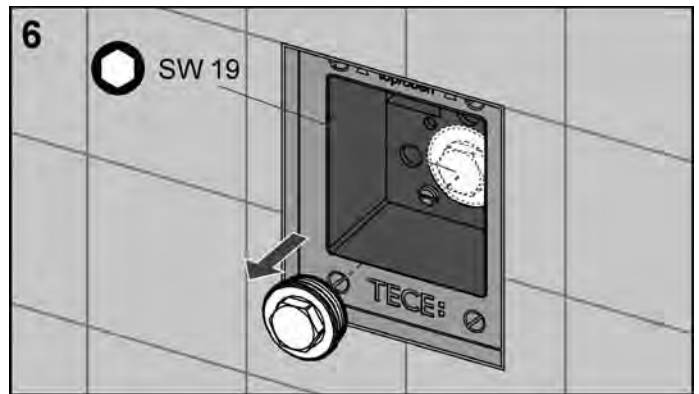

Remove the bare-wall plug.

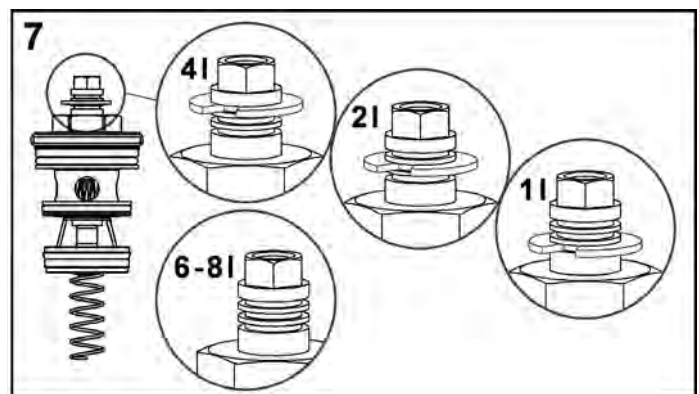

If necessary, make a flush volume setting before installing the cartridge (factory setting = 2 litres). To do this, remove the retaining ring and insert it back in the corresponding groove: The first groove corresponds to a flush volume of 1 litre, the second groove 2 litres, and the third groove 4 litres. Without a retaining ring, the flush valve flushes 6-8 litres.

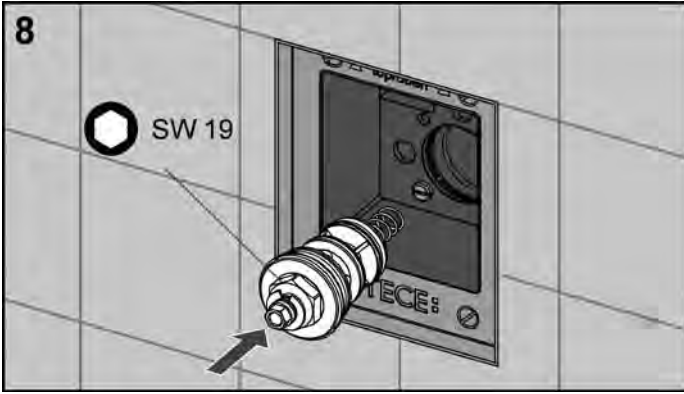

Screw in the mechanical cartridge.

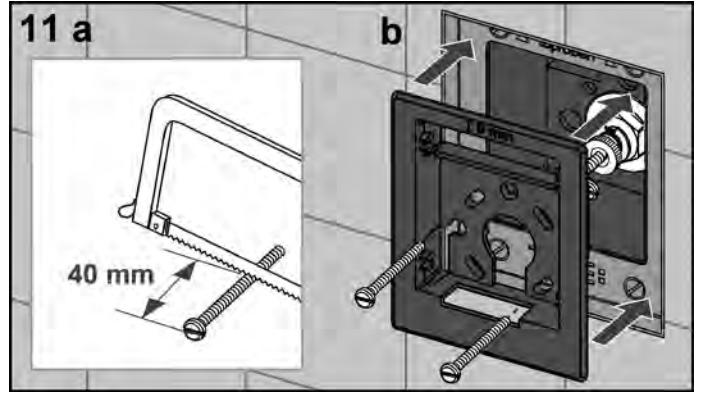

Screw the attaching frame to the urinal flush valve housing. If necessary, shorten the two screws so that they do not strike the mounting crossbeam (minimum length with minimum wall thickness = 40 mm).

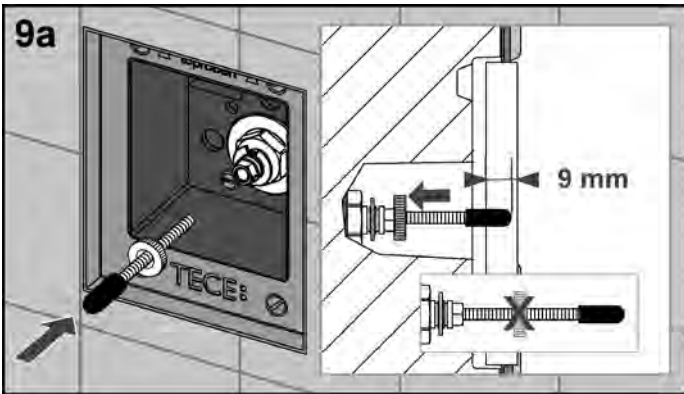

Screw the actuation rod in as far as specified (for TECEloop flush-mounted 9 mm distance to the front edge of the inner installation frame) and secure it against twisting with the lock nut.

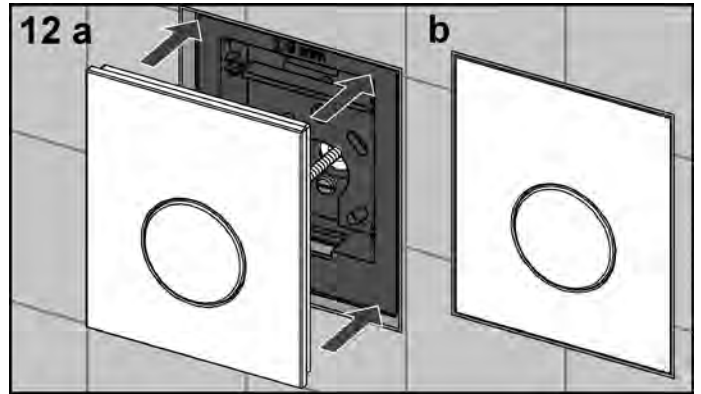

Snap the cover of the TECEloop push plate into the attaching frame.

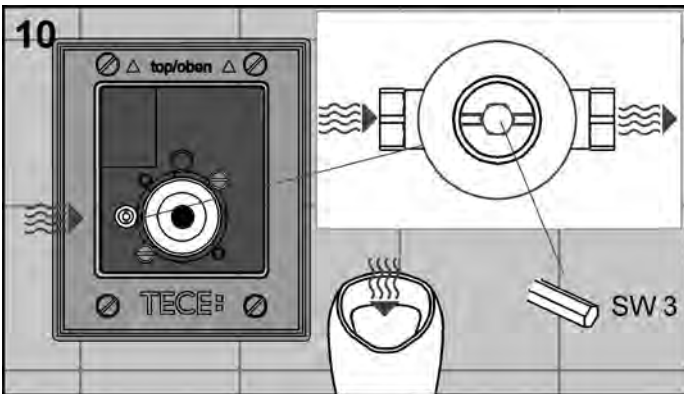

Open the inlet flow control.

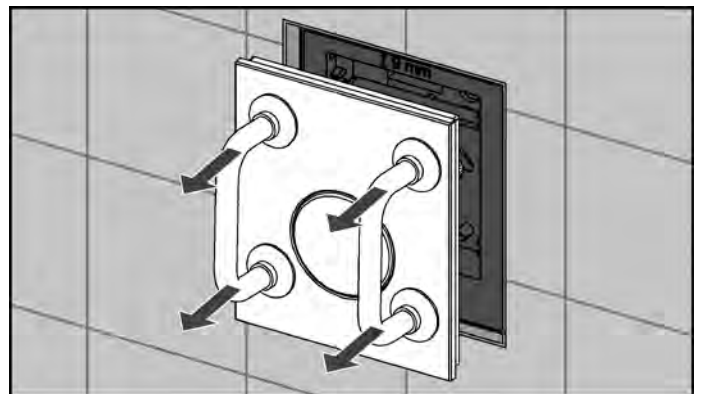

The installed cover can be removed from the actuation unit using the bow-type handles contained in the installation frame delivery. Position the suction cups only on the cover to be removed.

TECE push plates – TECEsquare

TECEsquare

The TECEsquare push plate is available for both the toilet and urinal with a glass or metal cover:

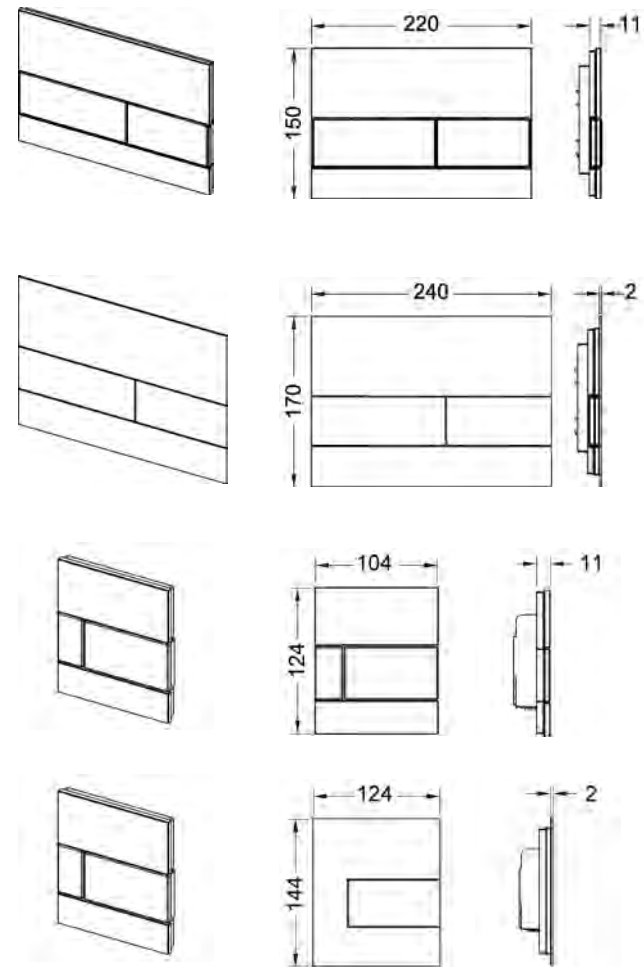

TECEsquare toilet push plate, glass
 TECEsquare toilet push plate, metal
 TECEsquare urinal push plate, glass
 TECEsquare urinal push plate, metal

As with TECEloop, the glass version can be installed in front of the tiles (surface-mounted) or flush-mounted using the toilet installation frame.

However, TECEsquare metal can ONLY be installed in conjunction with the flush-mounted installation frame (toilet and urinal):

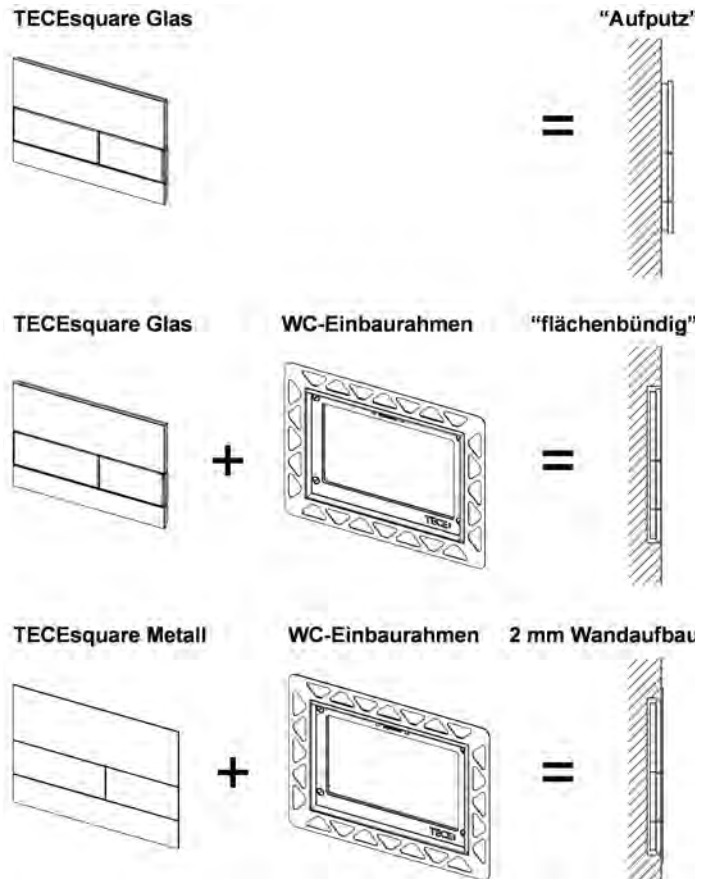

Installation of the TECEsquare push plates (for toilet and urinal push plates)

Installation of glass toilet push plate, surface-mounted

The first four steps for installation of the toilet push plate are the same for all TECE push plates (see section "TECEbase, installation of toilet push plate").

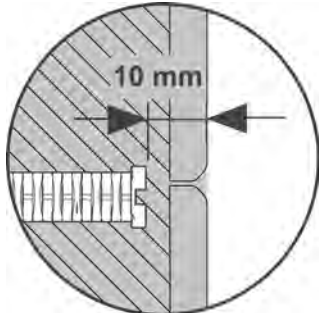
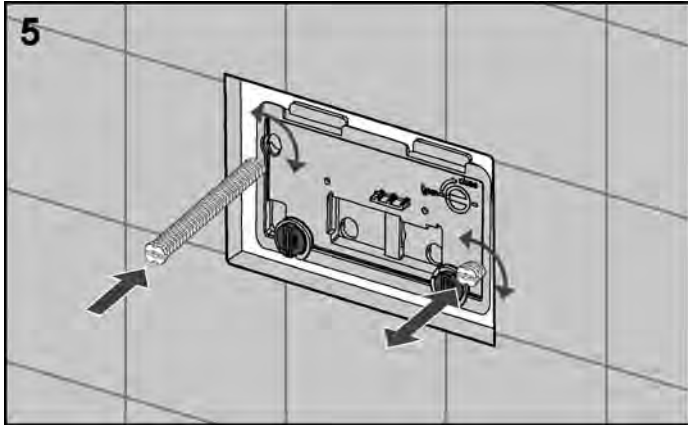

Screw in both attaching rods, and set the distance between the attaching rod and the wall surface to 10 mm.

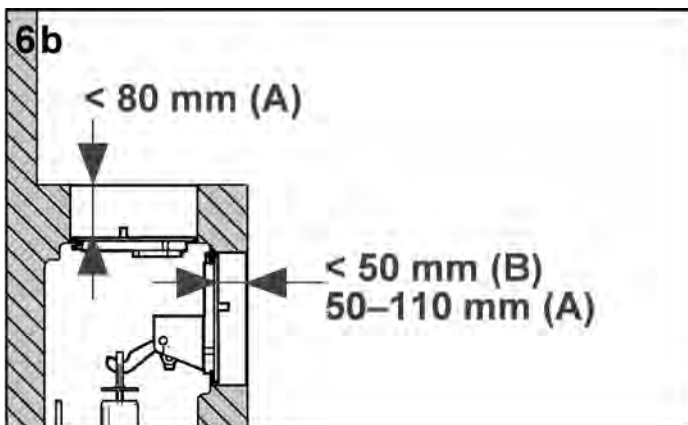
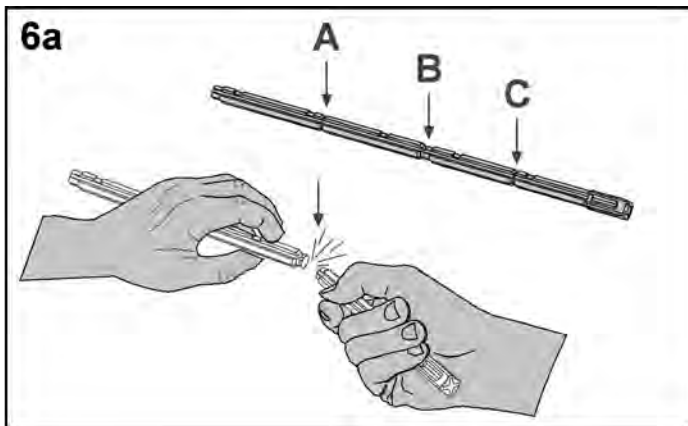

Snap off the actuation rods in accordance with the wall thickness.

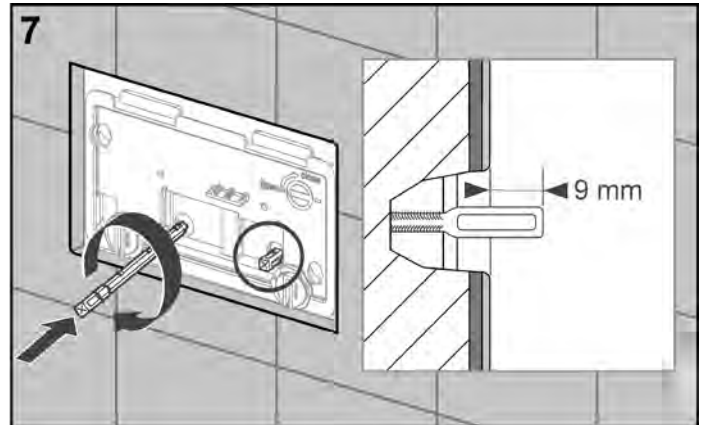

Screw in both actuation rods – distance between actuation rod and wall surface 9 mm.

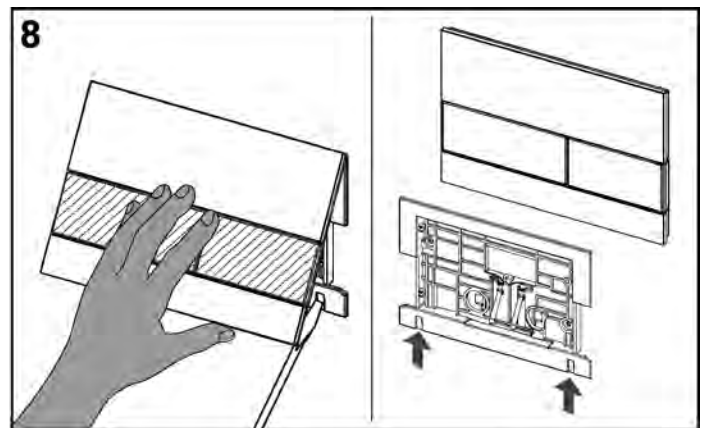

Use a screwdriver to detach the cover from the actuation unit. Insert the screwdriver in the recesses on the bottom side of the push plate and separate carefully.

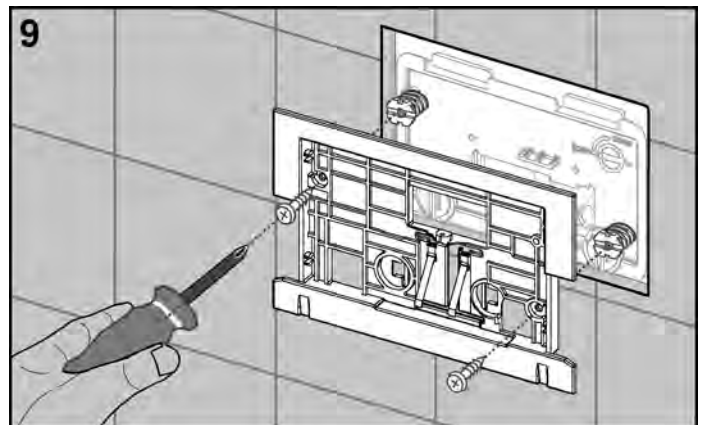

Screw the attaching frame onto the attaching rods.

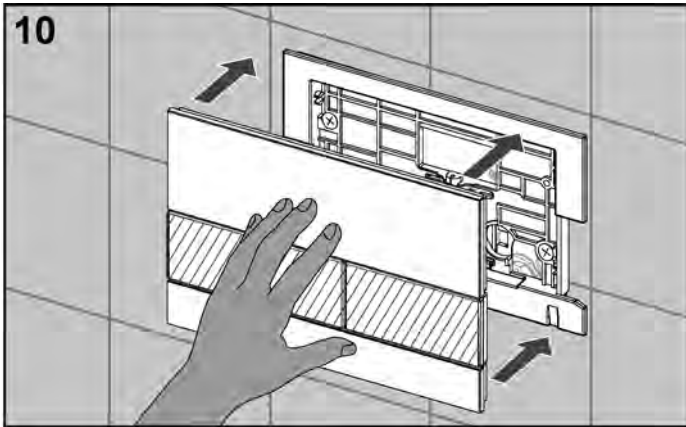

Snap the cover of the TECEsquare push plate onto the attaching frame.

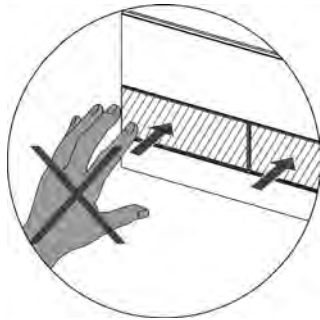
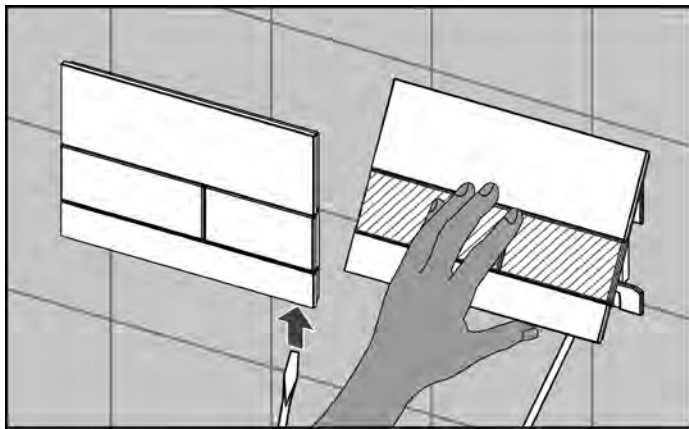

Use a screwdriver to detach the installed cover from the actuation unit. Insert the tool in the recesses on the bottom side of the push plate and remove it carefully.

Please note:

During installation, only apply force to the glass surfaces, not the buttons.

Installation of glass toilet push-plate, flush-mounted

The use of an installation frame is essential for the flush-mounted installation of TECEsquare glass. The installation frame must be installed before fine installation takes place (see section "Flush-mounted installation").

As with all TECE push plates the first four installation steps are the same for all toilet push plates (see section "TECEbase, toilet push plate installation").

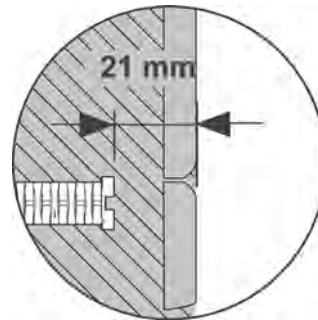
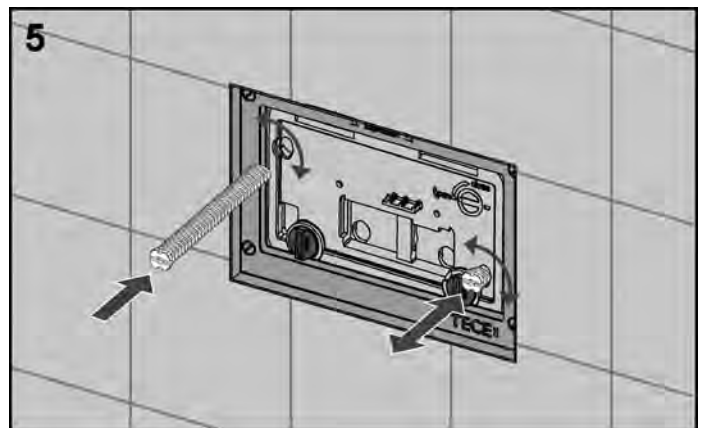

Screw in both attaching rods, and set the distance between the attaching rod and the wall surface to 21 mm.

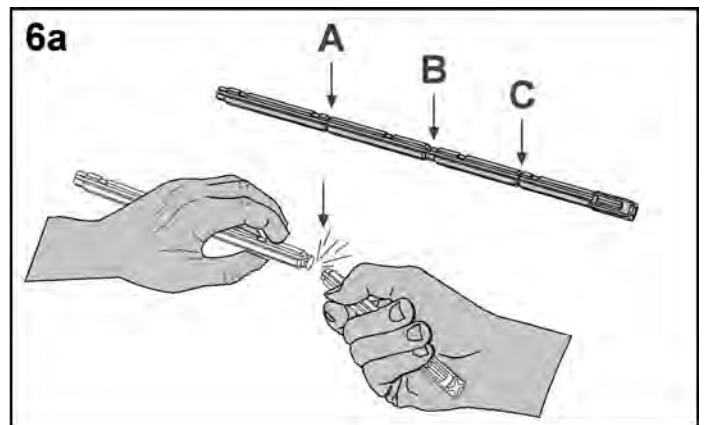

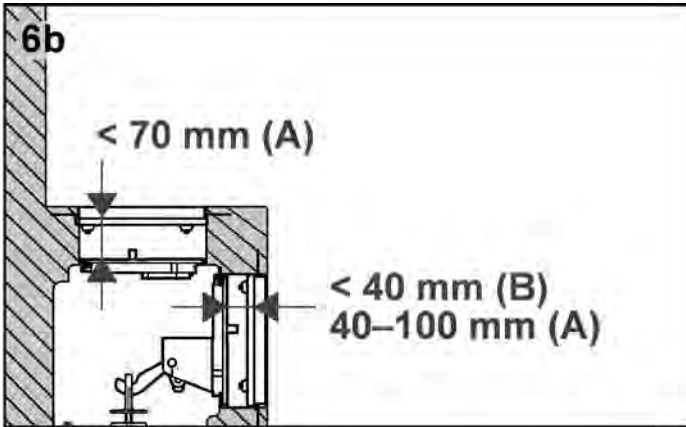

Snap off the actuation rods in accordance with the wall thickness.

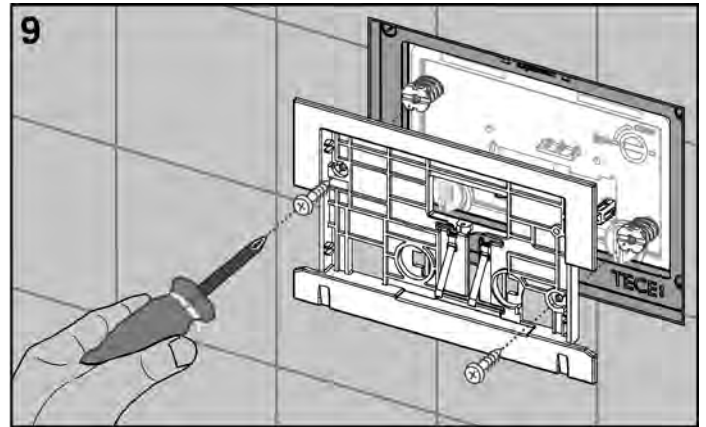

Screw the attaching frame onto the attaching rods.

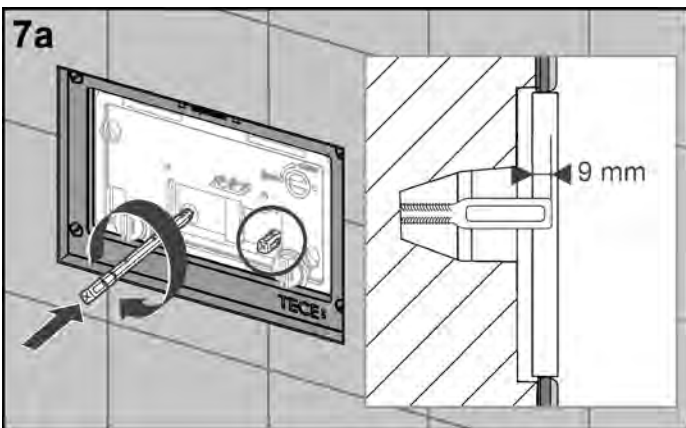

Screw in the actuation rods, set the distance to the front edge of the inner frame to 9 mm.

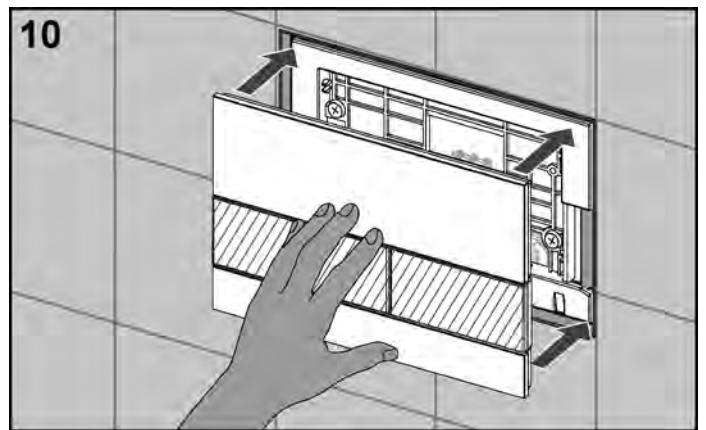

Snap the cover of the TECEsquare push plate into the attaching frame.

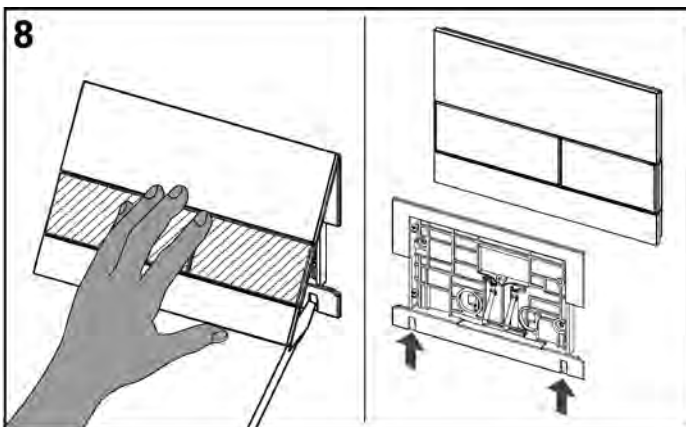

Use a screwdriver to detach the cover from the actuation unit. Insert the screwdriver in the recesses on the bottom side of the push plate and separate carefully.

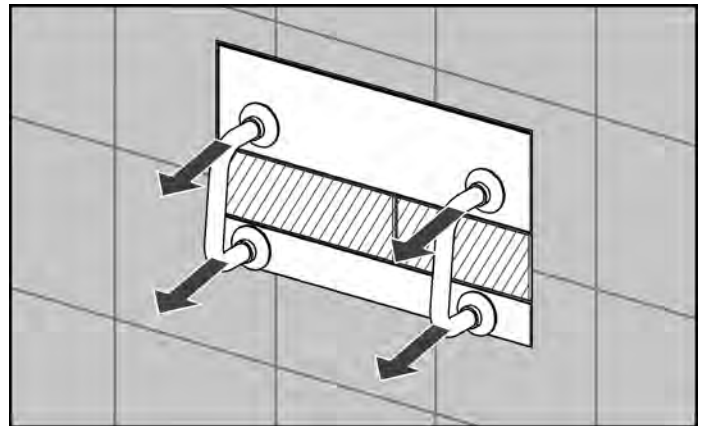

The installed cover can be removed from the actuation unit using the bow-type handles contained in the installation frame delivery.

TECE push plates – TECEsquare

Please note:

To do this, only position the suction cup on the glass surfaces – not the buttons – of the cover to be removed. During installation, only apply force to the glass surfaces, not the buttons.

Installation of metal toilet push plate

Installation of TECEsquare metal is identical to the flush-mounted installation of the glass toilet push plate (see section "TECEsquare – installation of glass toilet push plate, surface mounted").

Note:

Installation is always carried out with the toilet installation frame (wall thickness 2 mm)

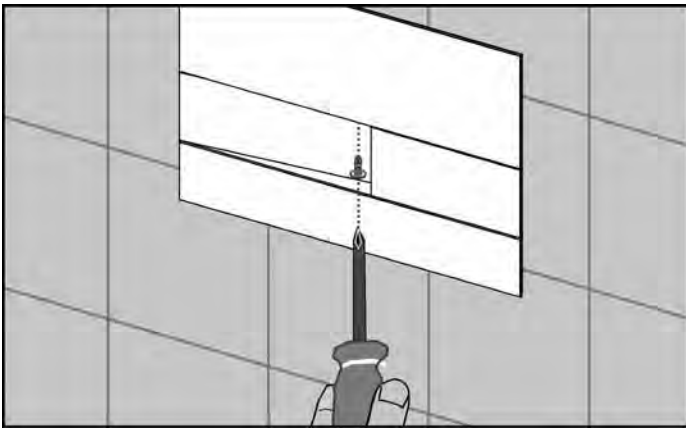

If necessary, TECEsquare metal can be fitted with a vandal-proof device (order number 9 820 249) (take care not to damage the surface).

Installation of glass urinal push plate, surface-mounted

The surface-mounted installation of the TECEsquare urinal push plates with a glass cover is practically identical to the installation of TECEloop (see section "TECEloop – installation of plastic urinal push plate, surface-mounted").

The button should not be pressed during installation (top) or removal (bottom) of the cover:

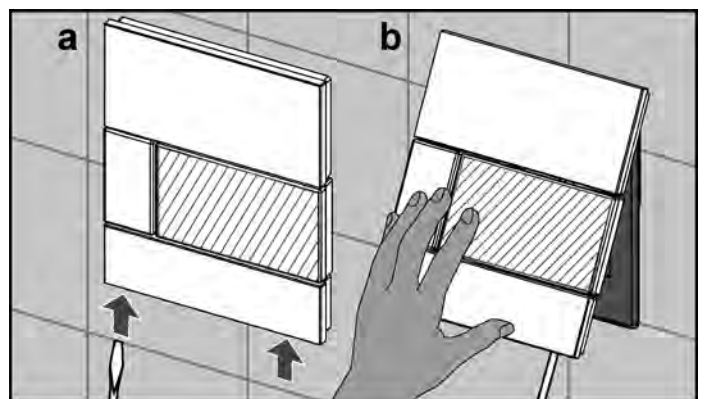
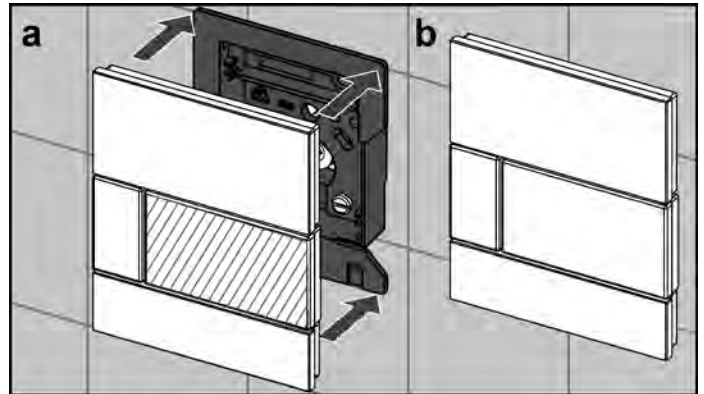

Installation of glass urinal push plate, flush-mounted

The flush-mounted installation of the TECESquare urinal push plates with a glass cover is practically identical to the flush-mounted installation of TECEloop (see section "TECEloop – installation of glass urinal push plate, flush-mounted").

As with surface-mounted installation, the button should not be pressed during installation or removal of the cover.

Installation of metal urinal push plate

The flush-mounted installation of the TECESquare urinal push plates with a glass cover is practically identical to the flush-mounted installation of TECEloop (see section "TECEloop – installation of glass urinal push plate, flush-mounted").

During installation or removal of the cover, the button should not be pressed. The cover should be removed using the suction cups only.

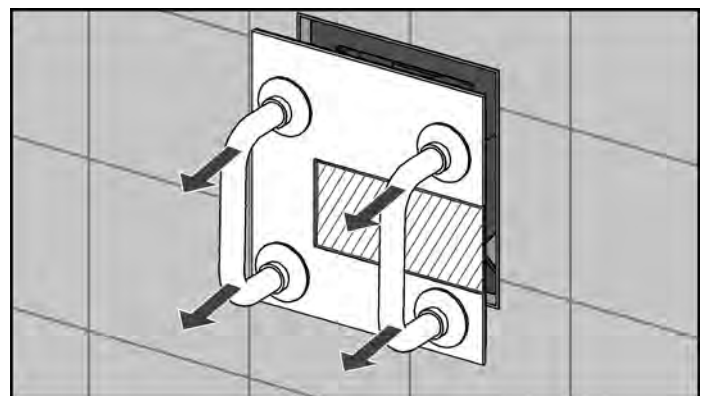
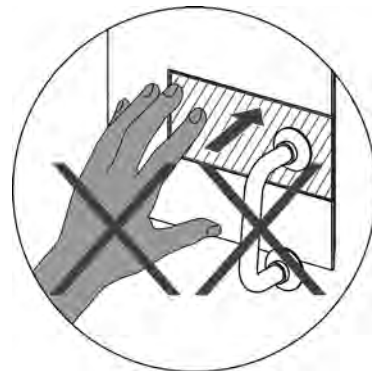
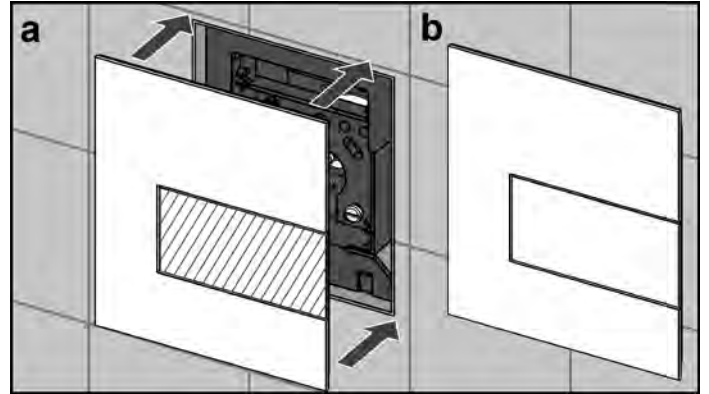

TECE push plates – flush-mounted installation

Flush-mounted installation

Flush-mounted installation is an outstanding feature of TECEloop glass (toilet and urinal) and TECESquare glass (toilet). If an installation frame is used, these push plates can be installed flush to the surface if required, both in a dry wall (toilet and urinal) and brick wall (toilet).

However, TECESquare metal must ALWAYS be installed using the installation frame. The metal plate then only projects 2 mm from the wall.

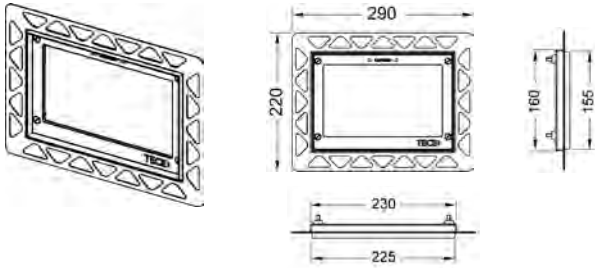

Flush-mounted installation frame for toilet push plate

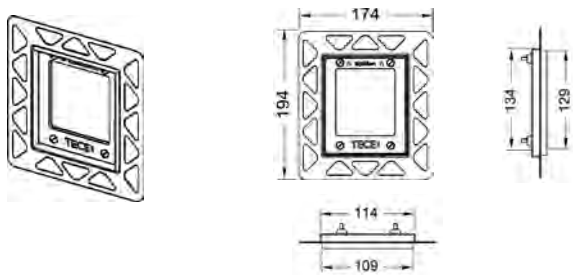

Flush-mounted installation frame for urinal push plate

Dry-wall construction – toilet push plate

The TECEprofil dry-wall module and the toilet installation frame are needed for a dry-wall construction. Dry-wall modules of all heights can be combined with the flush-mounted installation frame.

Components required:

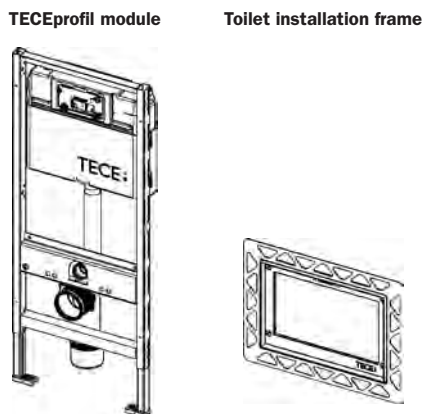

Installation of toilet push plate – dry-wall construction

To insert the installation frame in the plasterboard, a section must be cut out of the board for the cistern inspection opening.

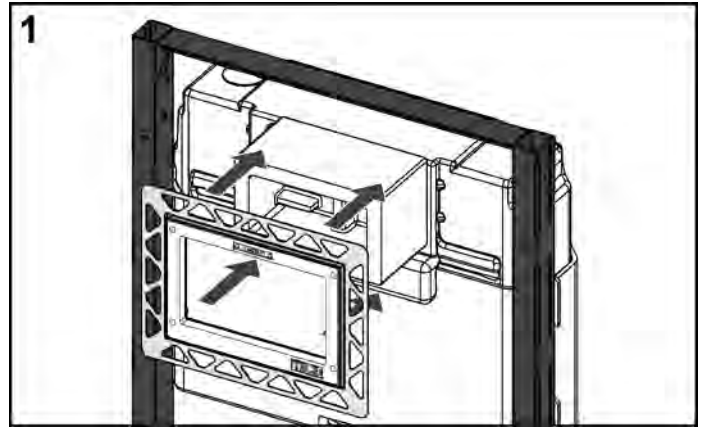

To do this, put the installation frame over the polystyrene bare-wall protection.

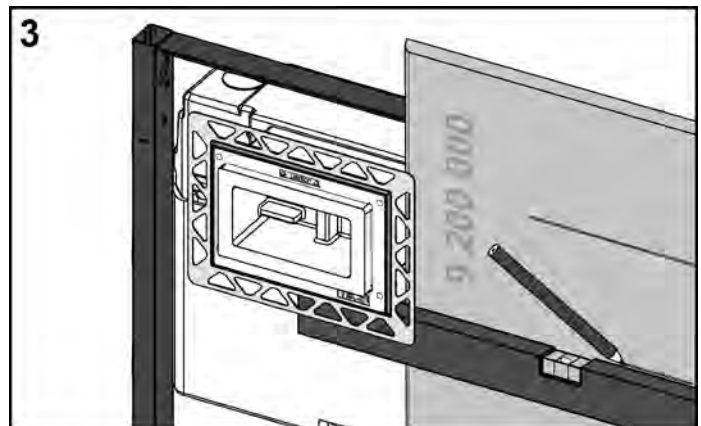
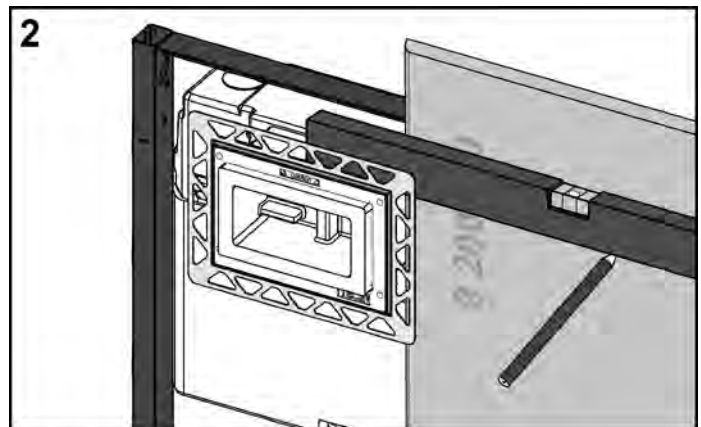

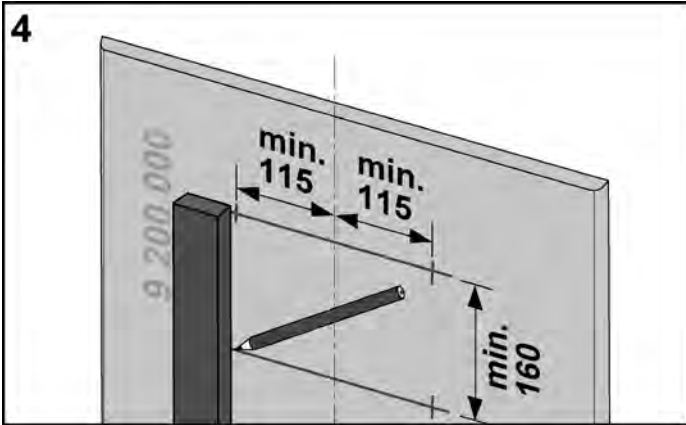

4 Draw the dimensions of the inner installation frame – width 230 mm, height 160 mm – centrally on the plasterboard.

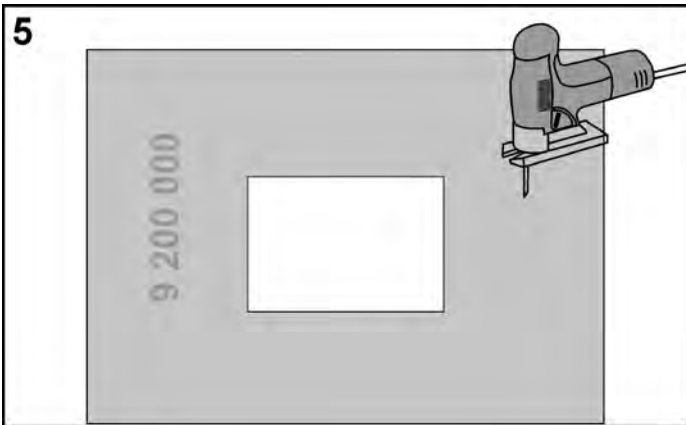
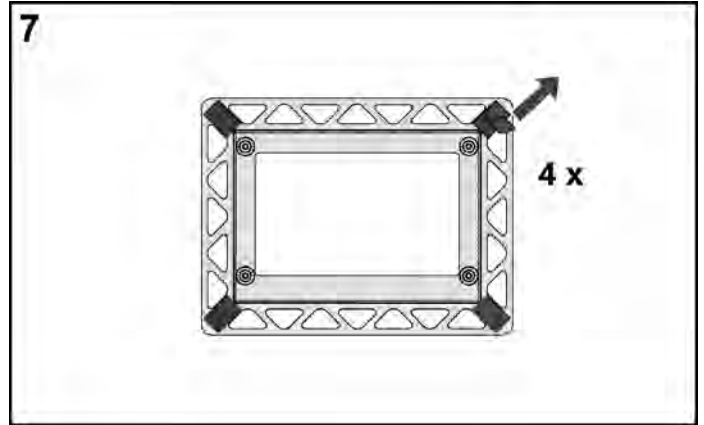

5 Saw out the required opening for the installation frame on the board.

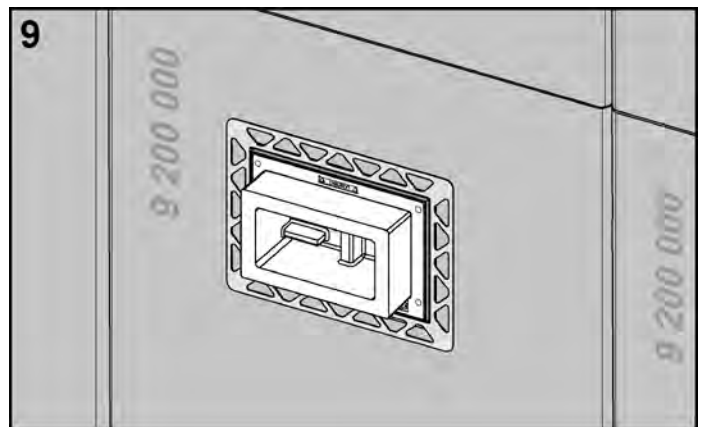
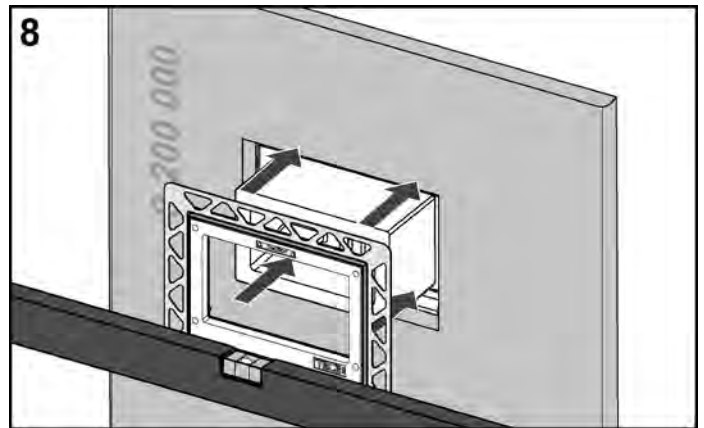

8 Remove the protective foil from the gluing points of the installation frame and glue it, together with the support frame, onto the plasterboard. Make sure the marking "TOP/oben" is positioned correctly and that it is horizontally aligned.

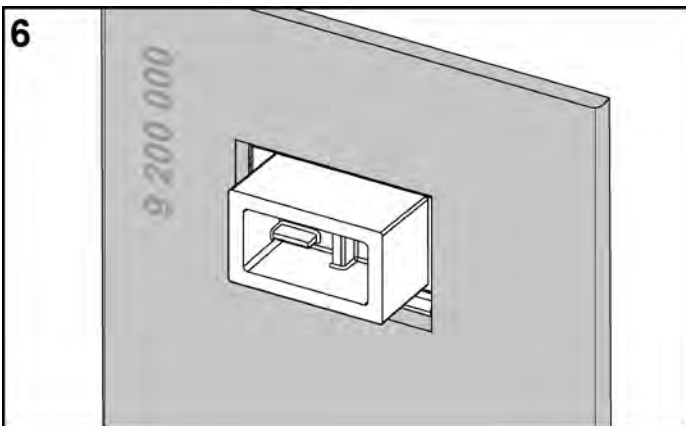

6 Screw the plasterboard onto the module centrally.

TECE push plates – flush-mounted installation

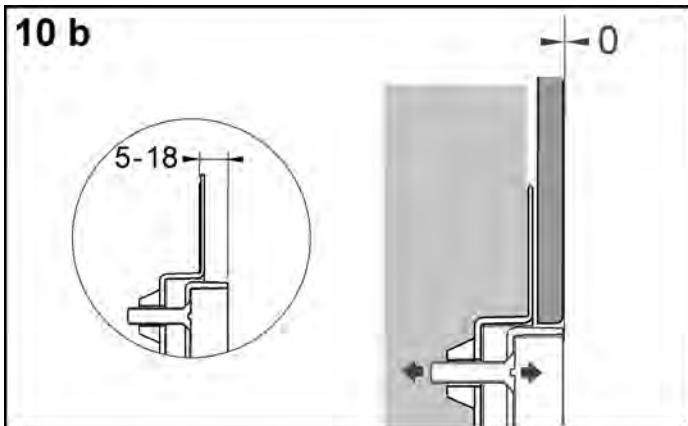
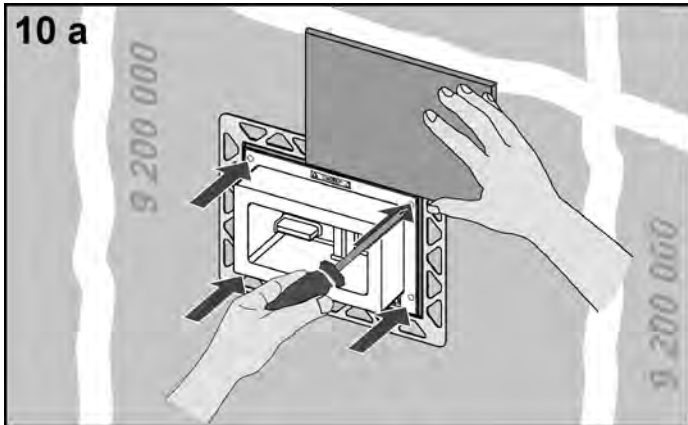

Set the depth of the installation frame in accordance with the tile thickness (5–18 mm). If the wall thickness is thicker (up to 33 mm), e.g. natural stone, you can use an upgrade set (order number 9 820 181).

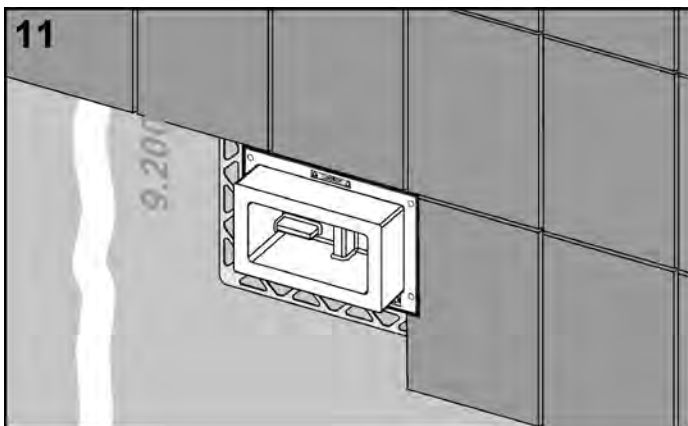

After adjusting the depth, you can tile in the installation frame.

Tip:

To obtain a perfect tile edge along the installation frame, TECE recommends using a water jet cutter to cut the tiles.

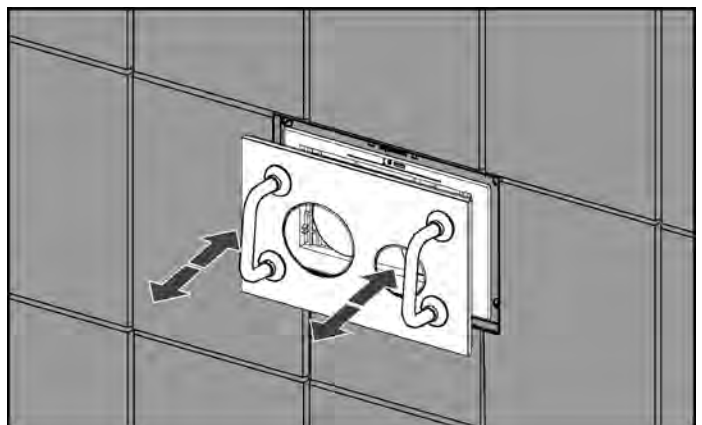
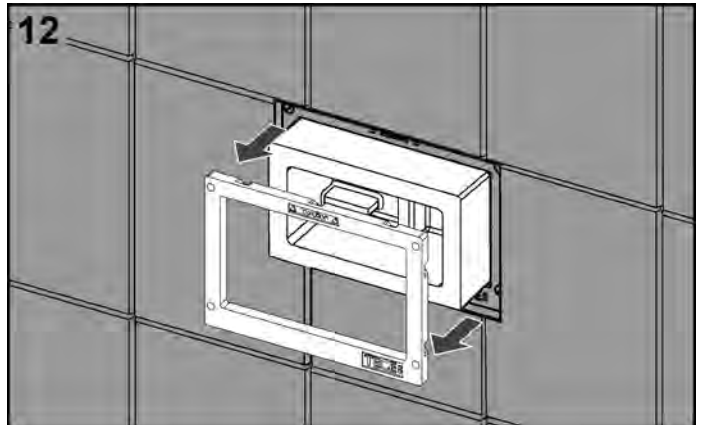

Remove the support frame and polystyrene bare-wall protection. Then mount the appropriate attaching frame, as described in the applicable installation instructions (TECEloop or TECESquare). Set the push plate in the flush-mounted installation frame using the bow-type handles included in the delivery.

Installation from top

Actuation from above is also possible with the flush-mounted installation frame. Installation is the same as for installation of a front-actuation push plate. The frame must be mounted in "reading direction" (= lettering "TOP/oben" to the wall).

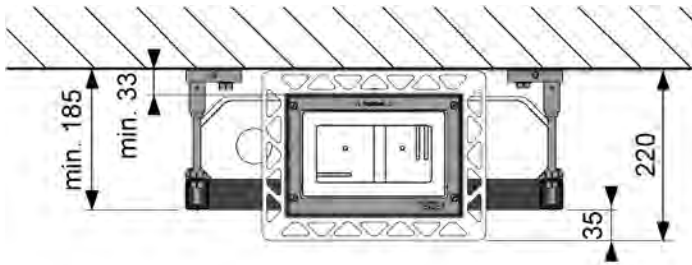

Flush-mounted installation from top – dimensions

However, a larger minimum facing is required because of the installation frame dimensions:
 A minimum facing of 35 mm corresponds to a facing with
 - 2 x 18 mm or
 - 3 x 12.5 mm thick plasterboards.

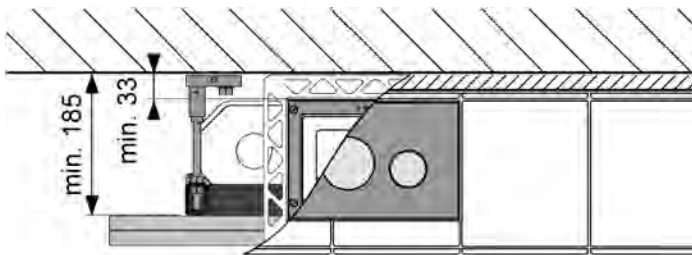

Flush-mounted installation from top – minimum wall thickness

In the case of a minimum wall thickness, however, there is no space between the installed push plate and the wall (figure above). For aesthetic reasons, however, an equal distance in front of and behind the push plate is preferable (figure below). This also applies for the installation of TECEsquare metal with somewhat larger dimensions.

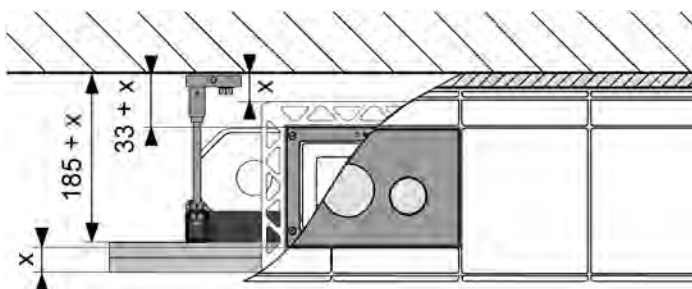

Flush-mounted installation from top – wall thickness (suggestion)

Brick wall – toilet push plate

In contrast to dry-wall construction, a larger bare-wall protection is needed for brick-wall construction, in addition to the TECEbox brick-wall cistern.

However, TECE cisterns of all installation heights can also be used in a brick-wall construction.

Components required:

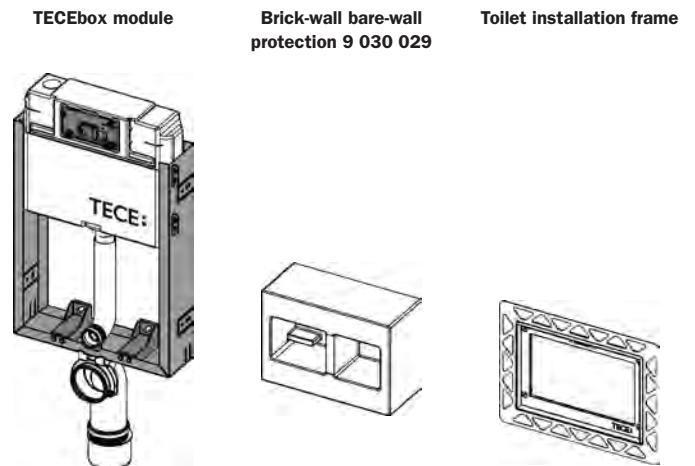

Installation of toilet push plate – brick-wall construction

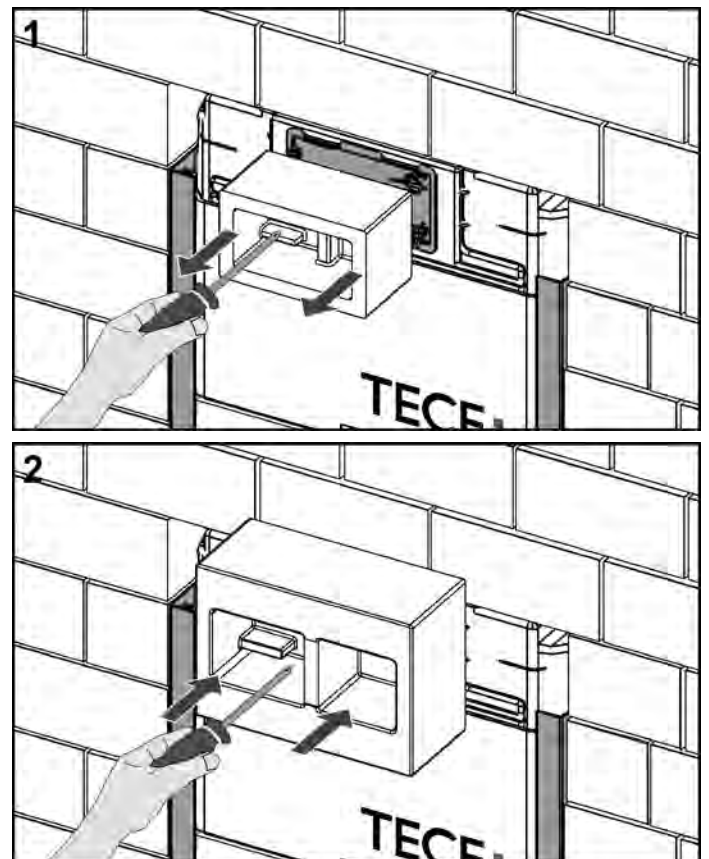

Remove the standard bare-wall protection and mount the larger brick-wall bare-wall protection for flush-mounted installation (order number 9 030 029).

TECE push plates – flush-mounted installation

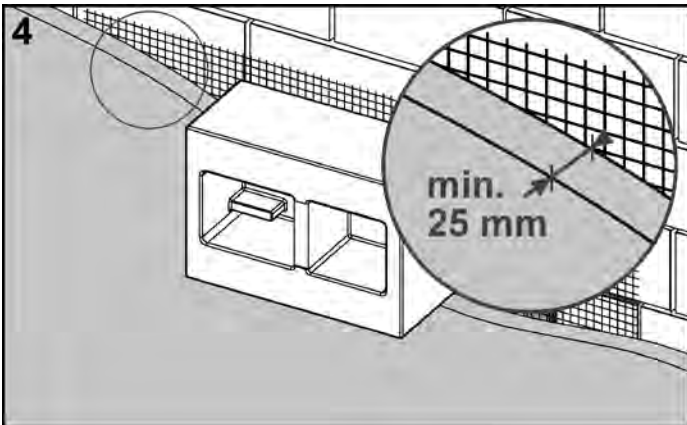
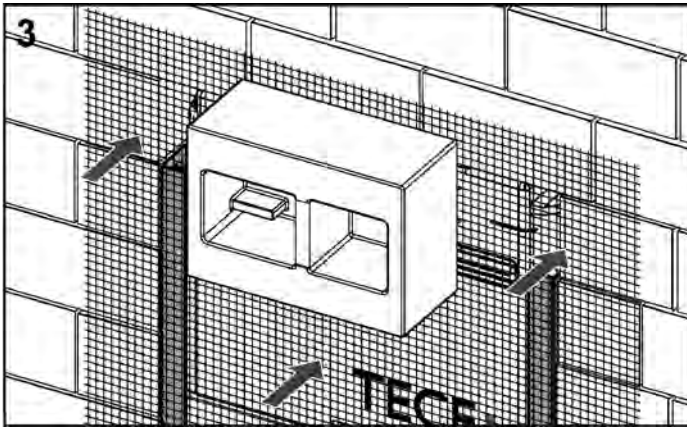

Attach expanded metal, reinforcing tape or similar in the cistern area. Apply a plaster layer at least 25 mm thick (measured from the front edge of the splash guard) to the wall.

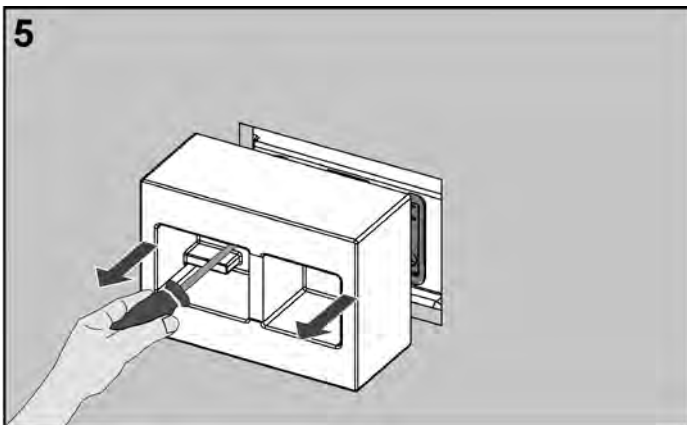

Remove the brick-wall bare-wall protection.

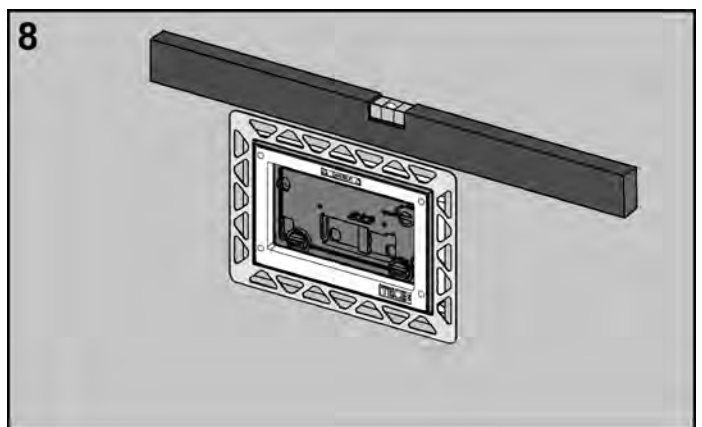
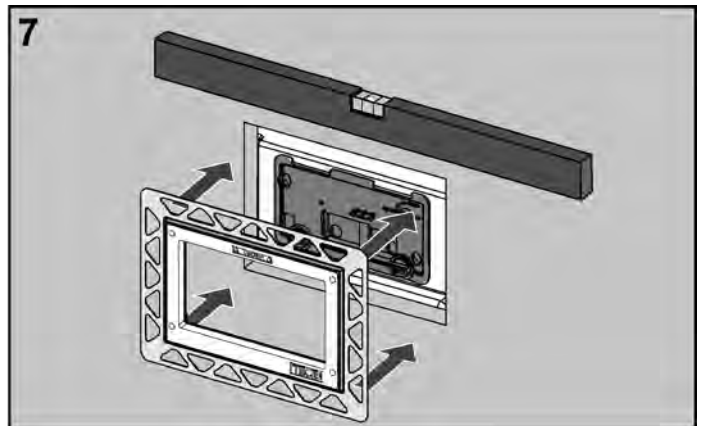
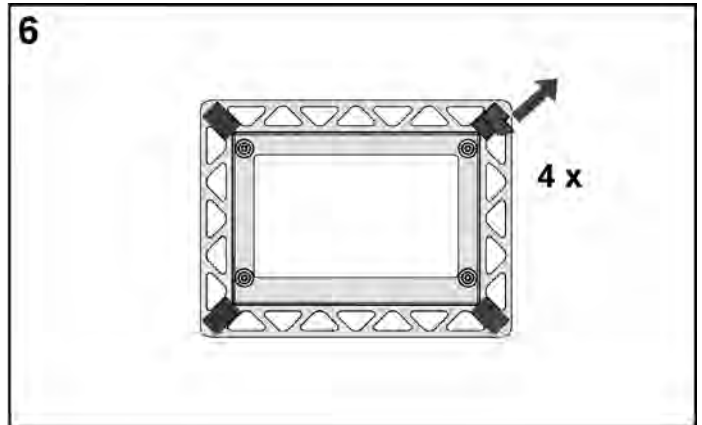

Remove the protective foil from the gluing points of the installation frame and glue it, together with the support frame, onto the plaster surface. Make sure the marking "TOP/oben" is positioned correctly and that it is horizontally aligned.

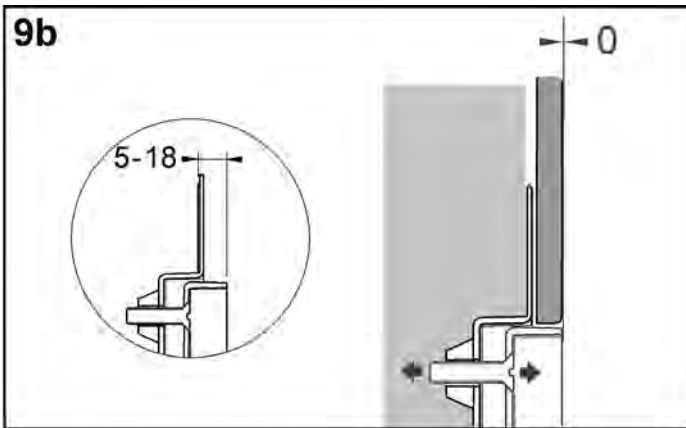
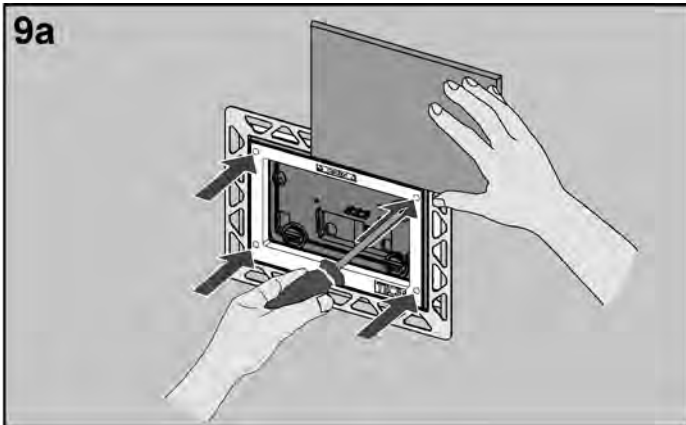

Set the depth of the installation frame in accordance with the tile thickness (5–18 mm). If the wall thickness is thicker (up to 33 mm), e.g. natural stone, you can use an upgrade set (order number 9 820 181).

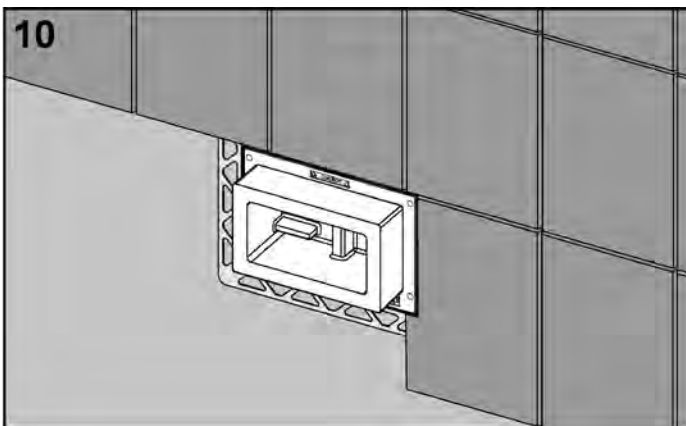

After adjusting the depth, you can tile in the installation frame.

Tip:

To obtain a perfect tile edge along the installation frame, TECE recommends using a water jet cutter to cut the tiles.

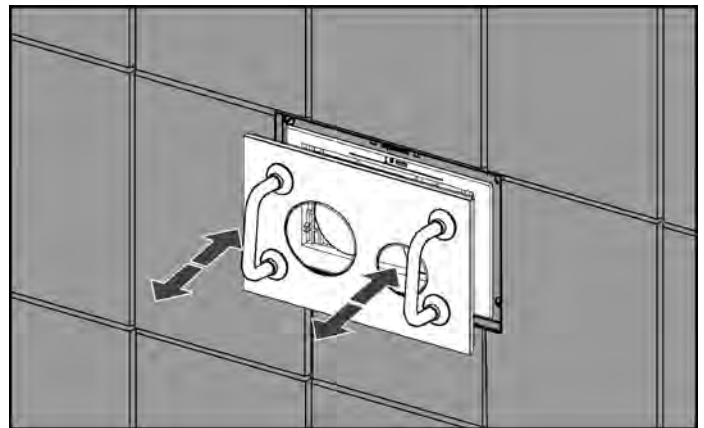
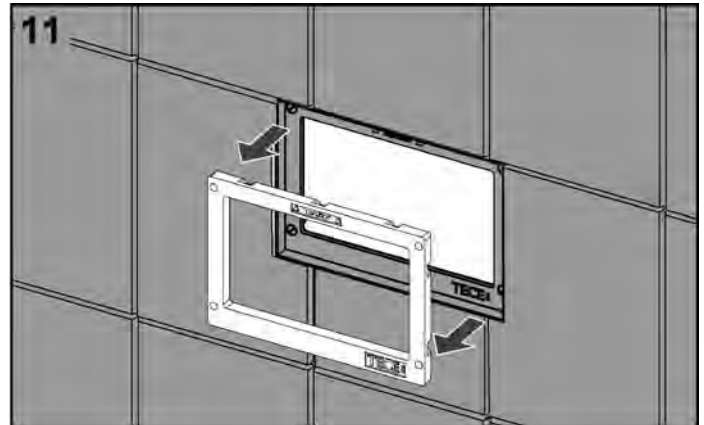

Remove the support frame and polystyrene bare-wall protection. Then mount the appropriate attaching frame, as described in the applicable installation instructions (TECEloop or TECESquare). Set the push plate in the flush-mounted installation frame using the bow-type handles. The handles are included in the installation frame delivery.

TECE push plates – flush-mounted installation

Installation from top

Actuation from above is also possible with the flush-mounted installation frame in a brick-wall construction. Installation is the same as for installation of a front-actuation push plate. The frame must be mounted in "reading direction" (= lettering "TOP/oben" to the wall).

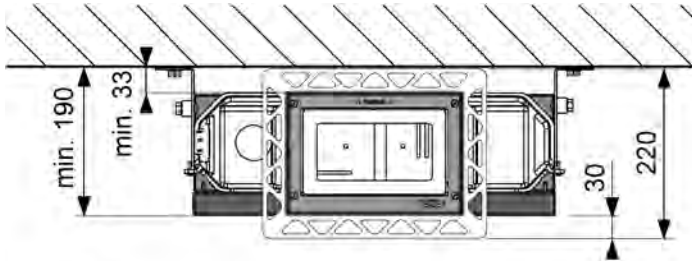

Flush-mounted installation from top – dimensions

However, a thicker wall is required because of the installation frame dimensions:
Minimum wall thickness = 30 mm

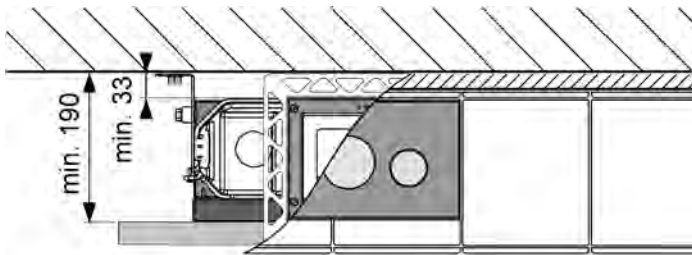

Flush-mounted installation from top – minimum wall thickness

In the case of a minimum wall thickness, however, there is no space between the installed push plate and the wall (figure above). For aesthetic reasons, however, an equal distance in front of and behind the push plate is preferable (figure below). This also applies for the installation of TECESquare metal with somewhat larger dimensions.

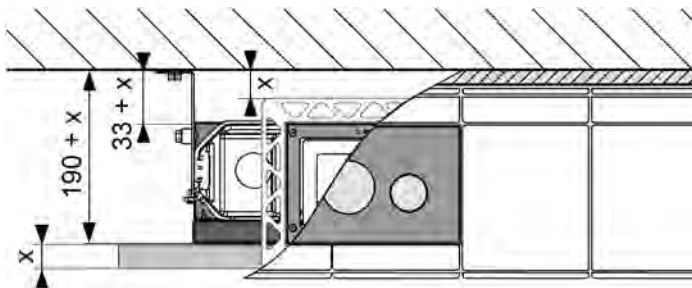

Flush-mounted installation from top – wall thickness (suggestion)

Dry-wall construction – urinal push plate

There is also a flush-mounted installation frame for the urinal. The TECEloop urinal push plate can be installed in dry walls with the help of this frame.

Installation of toilet urinal plate – dry-wall construction

To insert the flush-mounted installation frame in the plasterboard, a section must be cut out of the board for the cistern inspection opening.

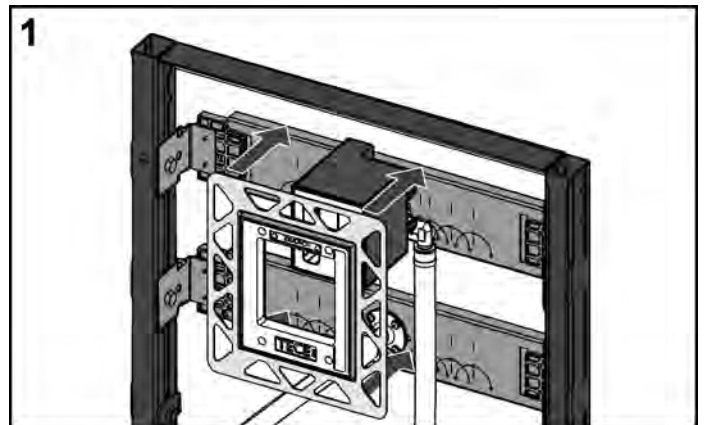

To do this, put the installation frame over the urinal bare-wall protection.

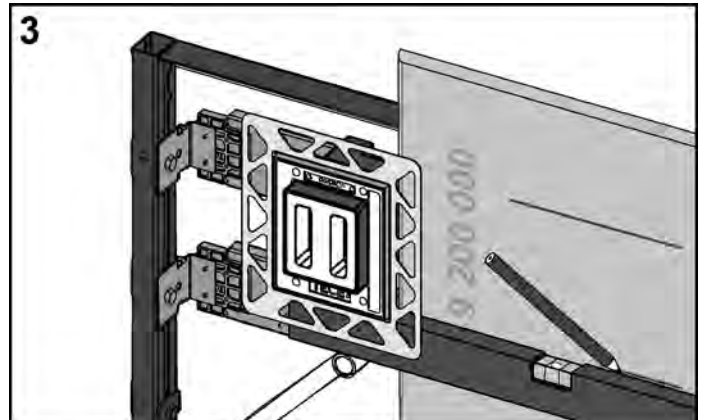
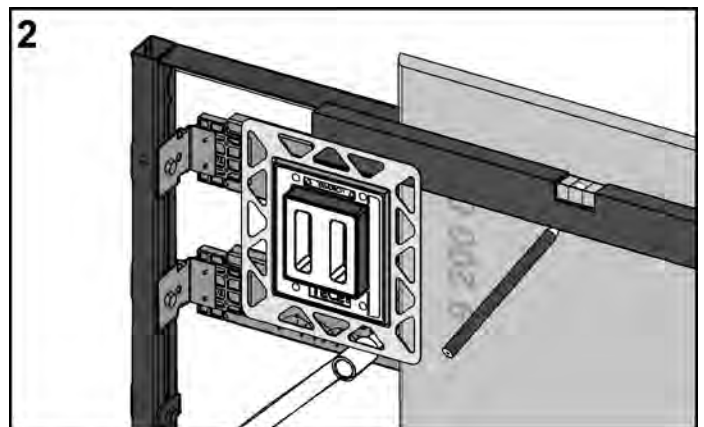

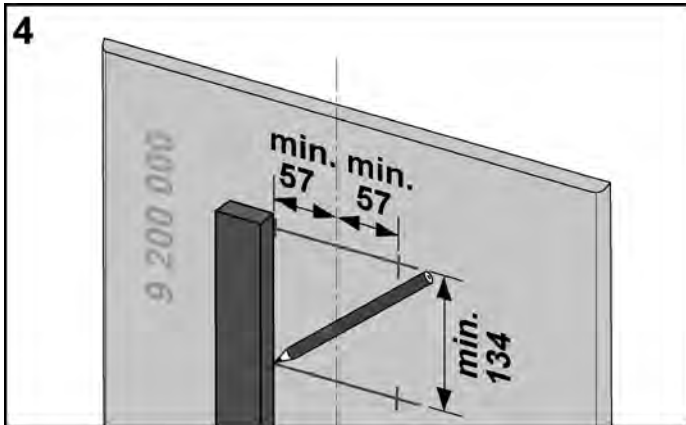

4 Draw the dimensions of the inner installation frame – width 114 mm, height 134 mm – centrally on the plasterboard.

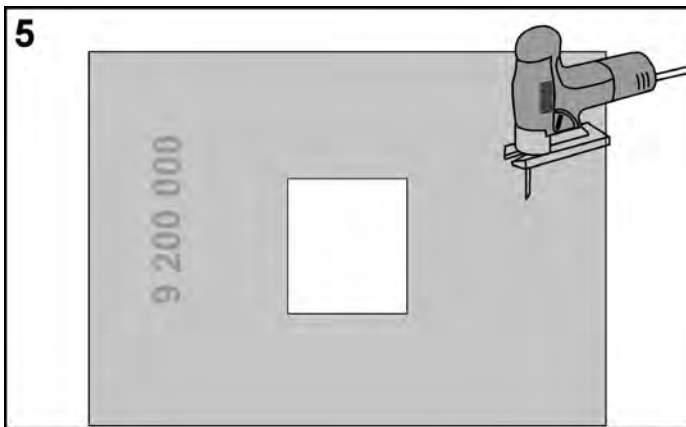

5 Saw out the required opening for the installation frame on the board.

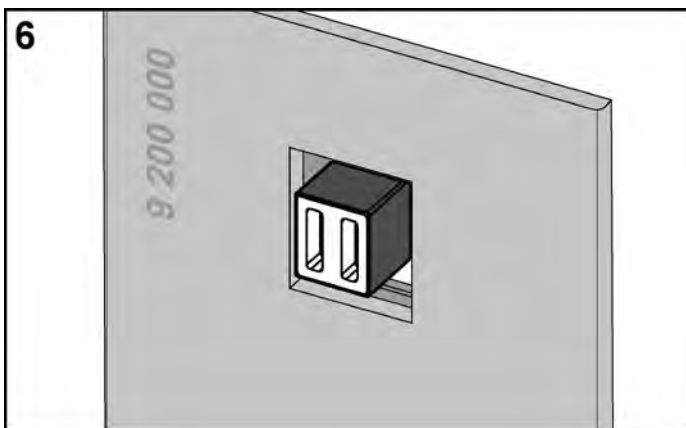

6 Screw the plasterboard onto the module centrally.

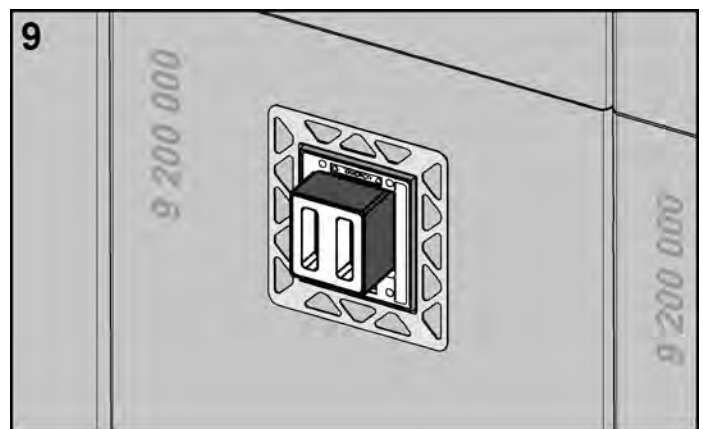
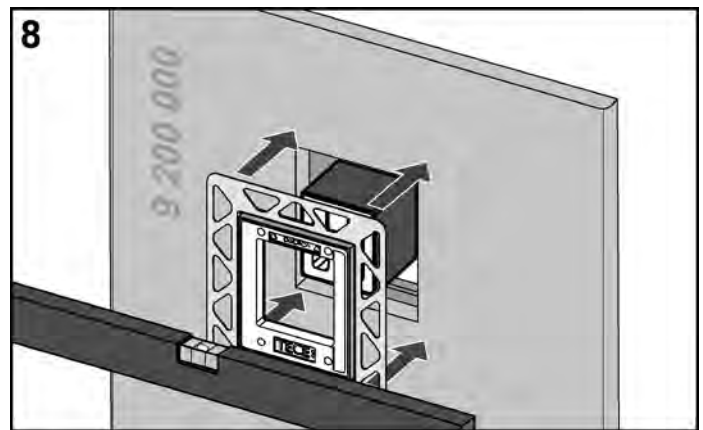
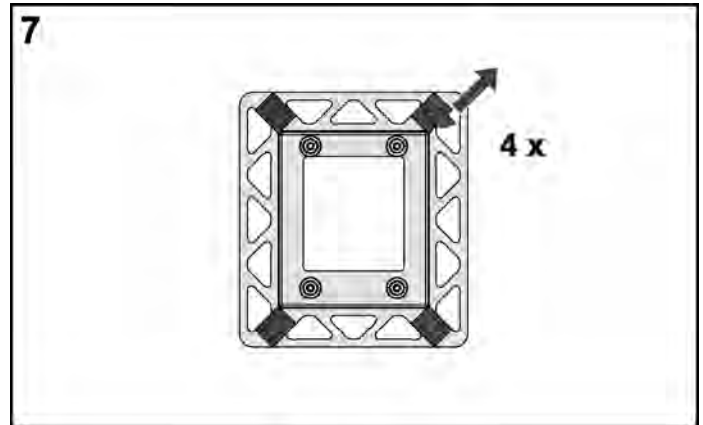

8 Remove the protective foil from the gluing points of the installation frame and glue it, together with the support frame, onto the plasterboard. Make sure the marking "TOP/oben" is positioned correctly and that it is horizontally aligned.

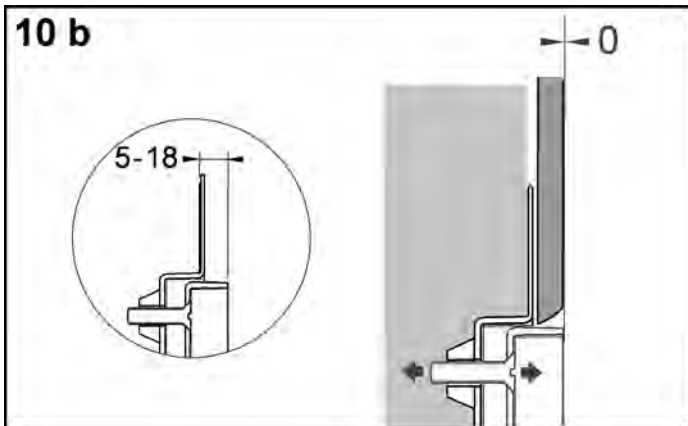
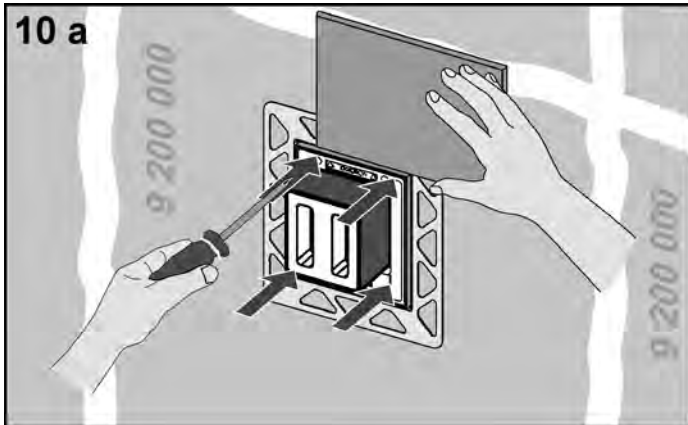

Set the depth of the installation frame in accordance with the tile thickness (5–18 mm). If the wall thickness is thicker (up to 33 mm), e.g. natural stone, you can use an upgrade set (order number 9 820 181).

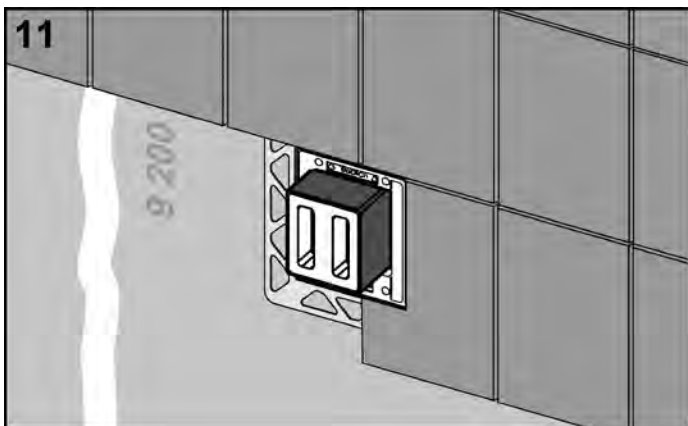

After adjusting the depth, you can tile in the installation frame.

Tip:

To obtain a perfect tile edge along the installation frame, TECE recommends using a water jet cutter to cut the tiles.

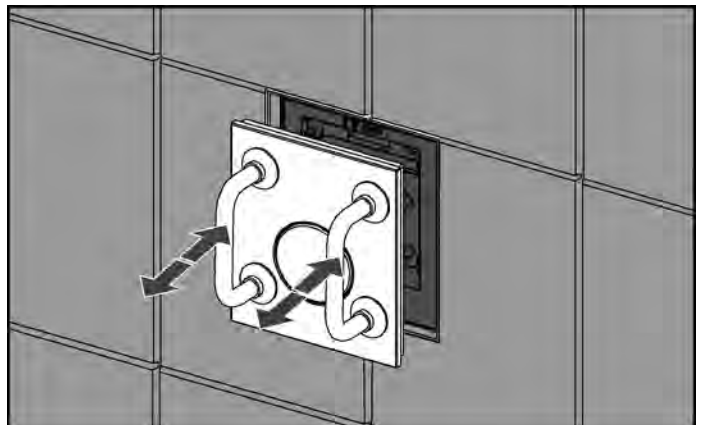
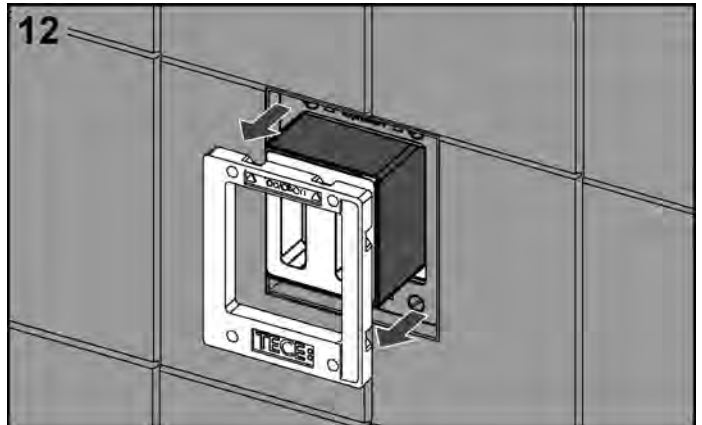

Remove the support frame and then follow the installation instructions (installation of the urinal cartridge, installation of the attaching frame, etc.). Set the push plate in the flush-mounted installation frame using the bow-type handles. The handles are included in the installation frame delivery.

Toilet flush handle

The toilet flush handle is a completely different way of actuating the flush, and can only be mounted on the TECE concealed cistern. It sets standards in terms of operation and design. The flush handle engineering makes it possible for a small or large flush handle to be actuated by a rotation movement.

Flush handles are offered by various bathroom fittings manufacturers. They are usually part of a fittings or accessories series or are "universal". The shape matched to the fittings enables a consistent design throughout the bathroom without disruptive elements. The flush handles are high-quality metal products.

It is possible to exchange a TECE push plate with a flush handle easily at any time. The customer can therefore decide at a later point in time to use a flush handle.

For flush handles, your contact is not TECE, but the fittings manufacturer that sells the flush handle:

DORNBRACHT

Dornbracht GmbH & Co. KG
Köbbingser Mühle 6
D-58640 Iserlohn
www.dornbracht.de
info@dornbracht.de

JADO

Jado AG Deutschland
Euskirchener Straße 80
D-53121 Bonn
Tel. +49 (0) 2 28 521-0
Fax +49 (0) 2 28 521-241
www.jado.de
jado.info@idealstandard.de

KLUDI

Kludi GmbH & Co. KG
Am Vogelsang 31-33
D-58706 Menden
Tel. +49 (0) 23 73 904-0
Fax +49 (0) 23 73 904-465
www.kludi.de
info@kludi.de

oras

ORAS GmbH & Co. KG
Armaturen
Grünlandweg 10
D-58640 Iserlohn
Tel. +49 (0) 23 71 94 80-0
Fax +49 (0) 23 71 94 80-23
www.oras.com
info.germany@oras.com

sam

sam Vertriebs GmbH + Co. KG
Horlecke 102
D-58706 Menden
Tel. +49 (0) 23 73 90 90 00
Fax +49 (0) 23 73 90 90 101
www.sam.de
office@sam.de

TECE push plates – flush handle

Rotary mechanism installation

The cover of a flush handle is installed differently depending on the manufacturer and series and the steps are described in the corresponding installation instructions. The rotary mechanism, which forms the basis for every flush handle, is installed as follows:

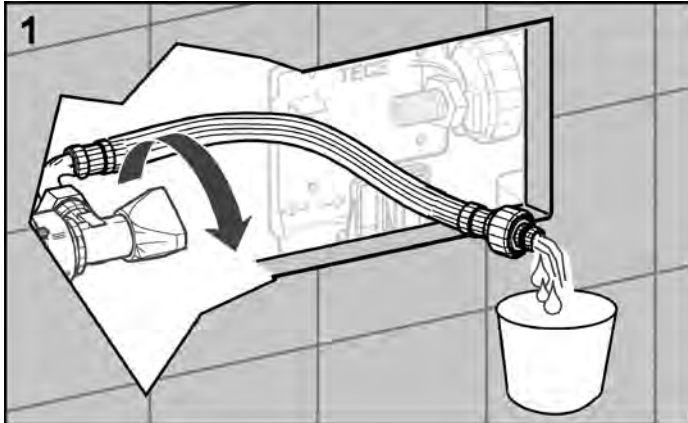

Open the corner valve and rinse out the pipe thoroughly.

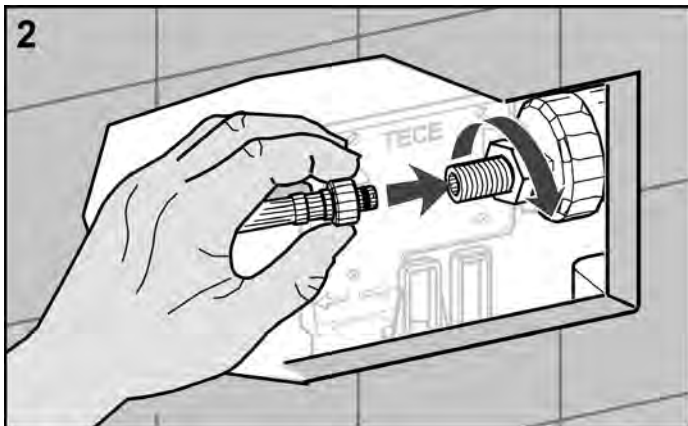

Close the corner valve again and attach the reinforced hose to the filling valve. If necessary, you can open the corner valve again now.

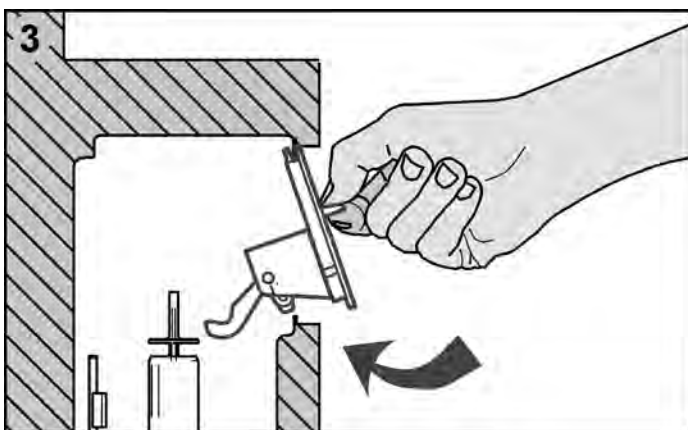

Replace the splash guard.

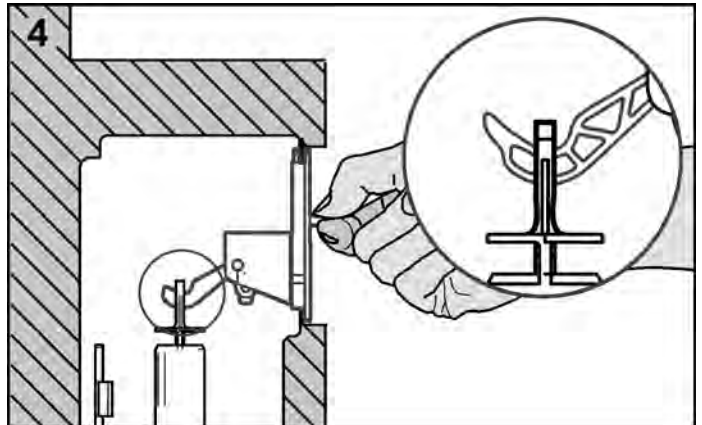

The actuation hooks must sit correctly in the lug of the drain valve. Tighten the attaching screws of the splash guard.

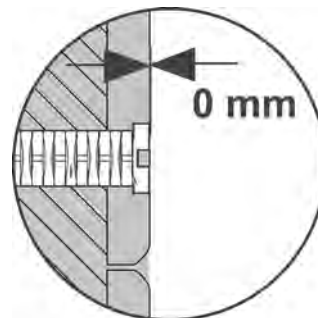
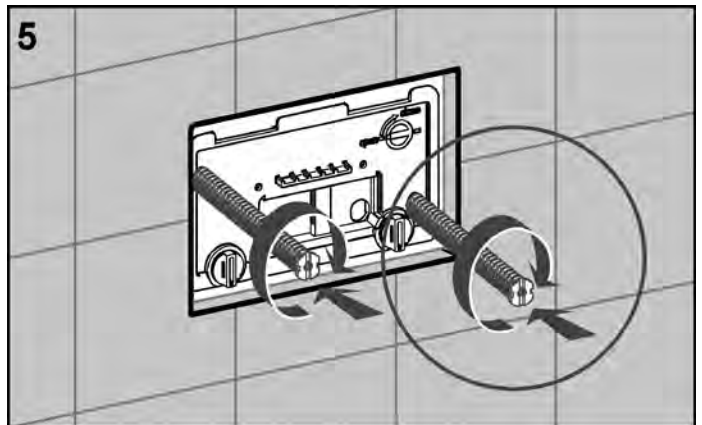

Screw both attaching rods in until they are at the same level as the wall surface.

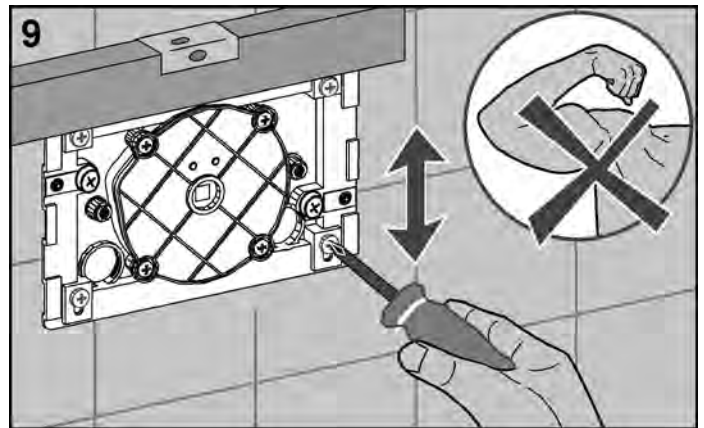
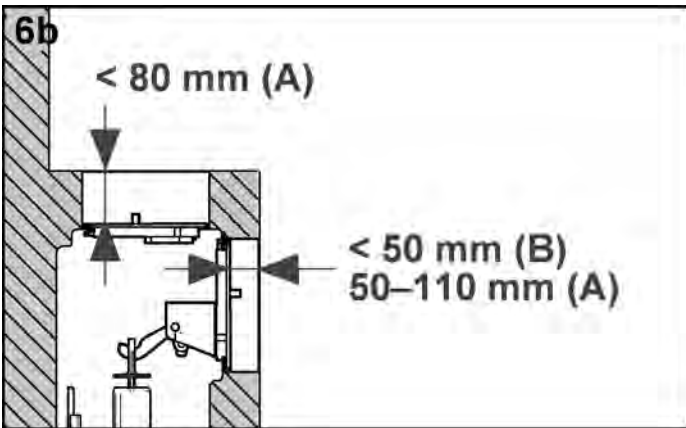
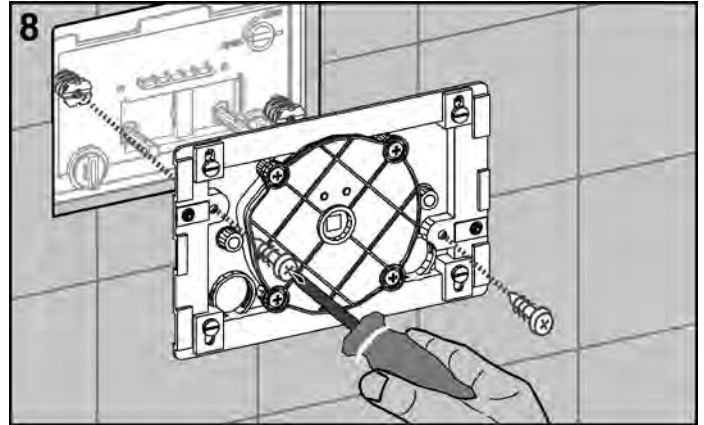
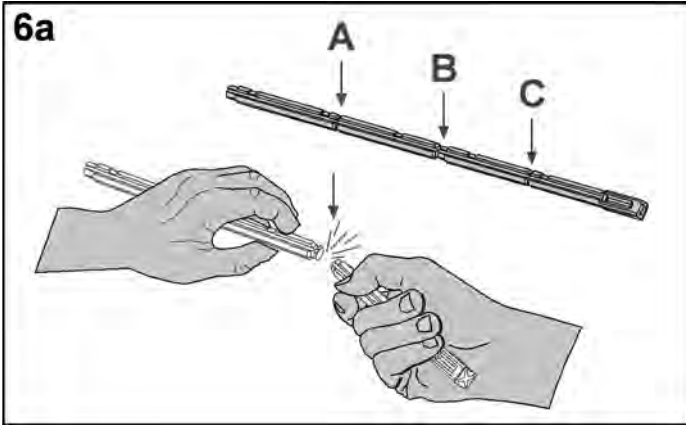

Snap off the actuation rods in accordance with the wall thickness.

Screw the rotary mechanism onto the attaching rods and align horizontally.

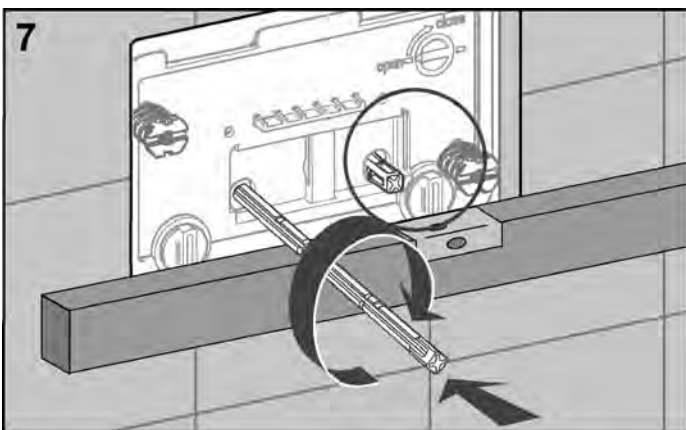

The covers are installed in accordance with the fittings manufacturer's instructions.

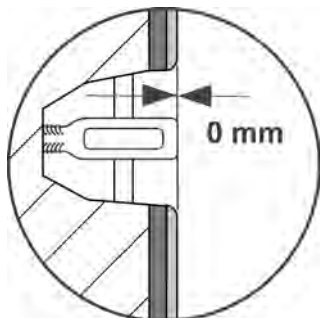

Screw both actuation rods in until they are at the same level as the wall surface.

TECE push plates – installation dimensions

Installation dimensions for TECE push plates

TECEbase

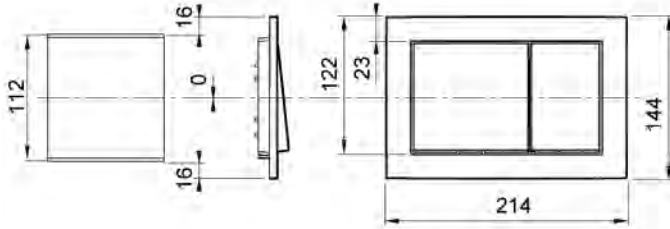

Dimensions of toilet push plate and bare-wall protection for vertical joint alignment

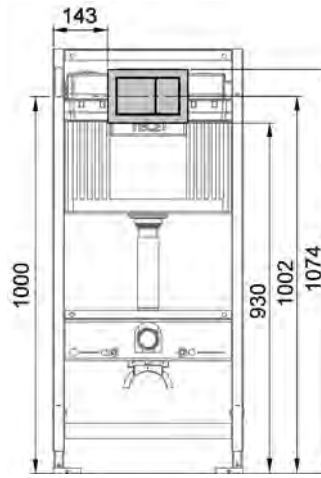

Toilet push plate (left) and urinal push plate (right) with module

TECEambia

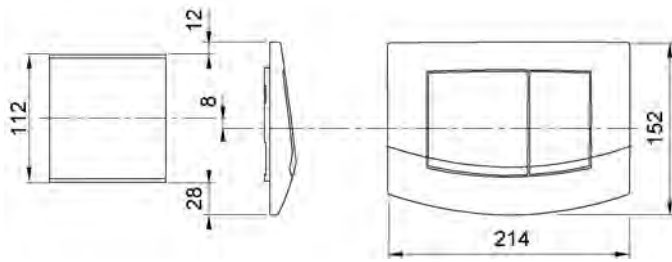

Dimensions of toilet push plate and bare-wall protection for vertical joint alignment

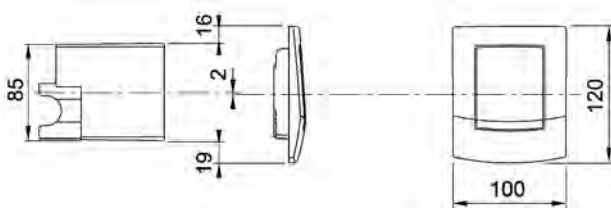

Urinal push plate and bare-wall protection for vertical joint alignment

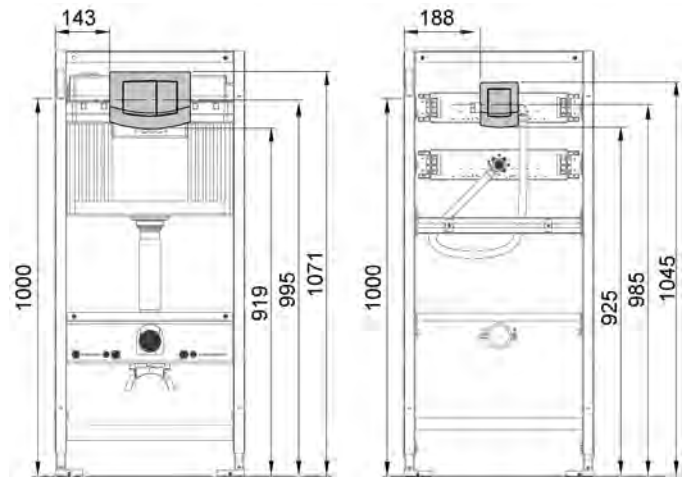

Toilet push plate (left) and urinal push plate (right) with module

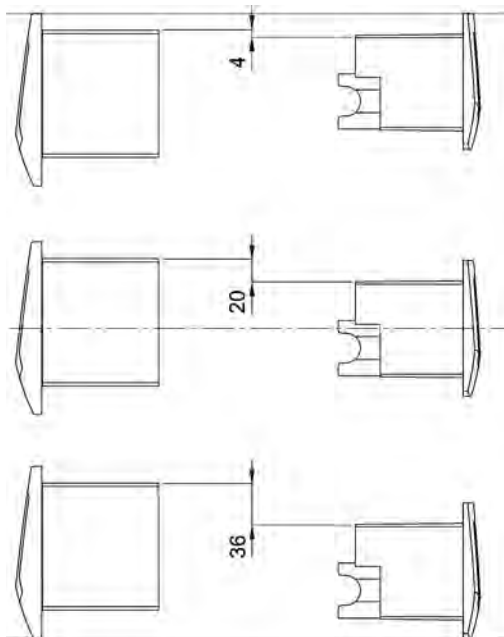

Toilet push plate (left) and urinal push plate (right):

- Installation top-aligned (figure top)
- Installation centred (figure centre)
- Installation bottom-aligned (figure below)

TECE push plates – installation dimensions

TECEloop plastic

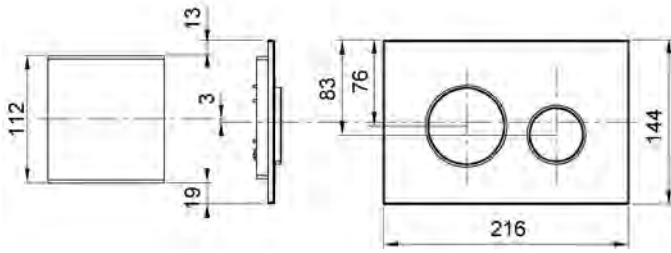

Dimensions of toilet push plate and bare-wall protection for vertical joint alignment

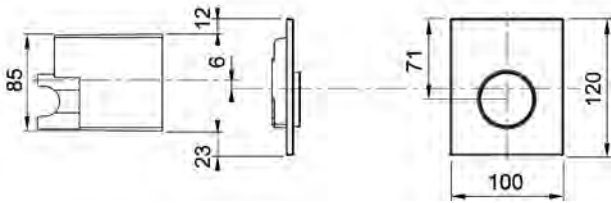

Urinal push plate and bare-wall protection for vertical joint alignment

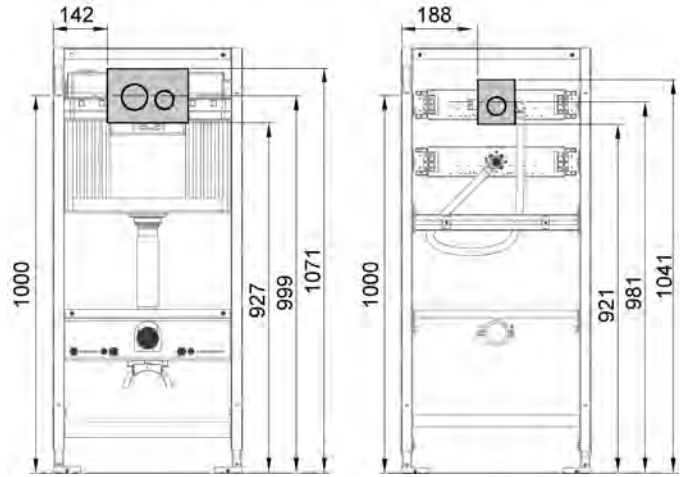

Toilet push plate (left) and urinal push plate (right) with module

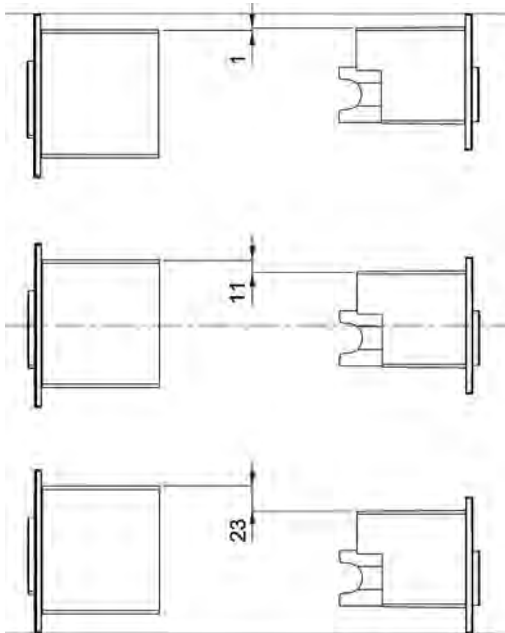

Toilet push plate (left) and urinal push plate (right):

- Installation top-aligned (figure top)
- Installation centred (figure centre)
- Installation bottom-aligned (figure below)

TECEloop glass

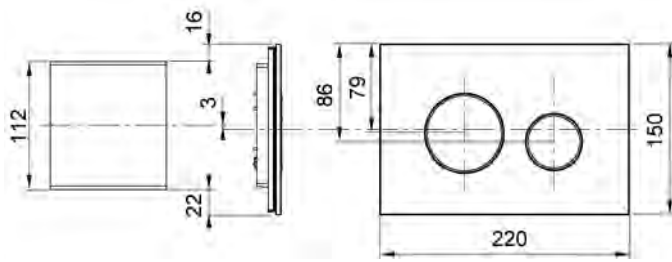

Dimensions of toilet push plate and bare-wall protection for vertical joint alignment

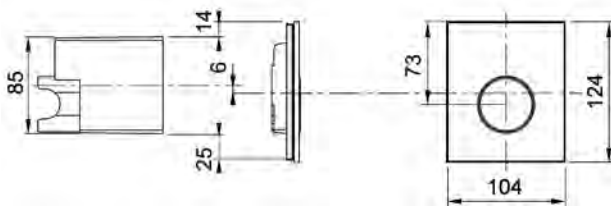

Urinal push plate and bare-wall protection for vertical joint alignment

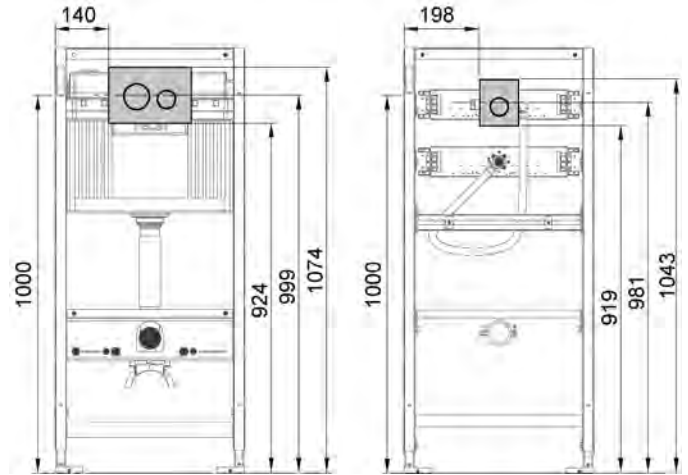

Toilet push plate (left) and urinal push plate (right) with module

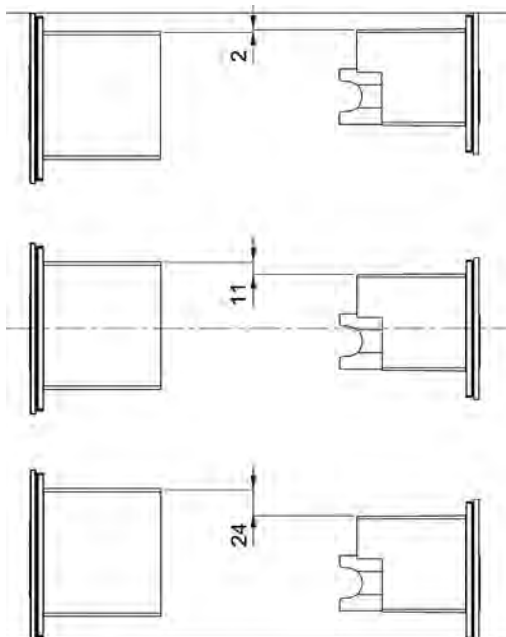

Toilet push plate (left) and urinal push plate (right):

- Installation top-aligned (figure top)
- Installation centred (figure centre)
- Installation bottom-aligned (figure below)

TECE push plates – installation dimensions

TECEsquare glass

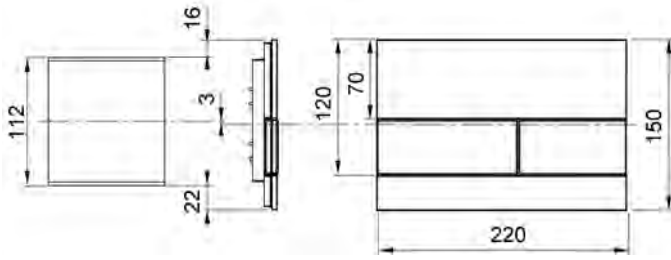

Dimensions of toilet push plate and bare-wall protection for vertical joint alignment

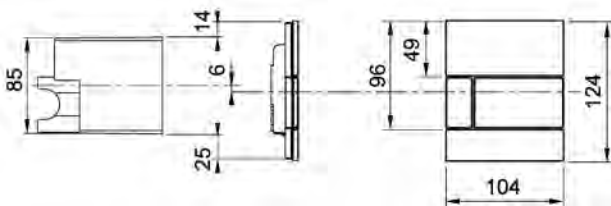

Urinal push plate and bare-wall protection for vertical joint alignment

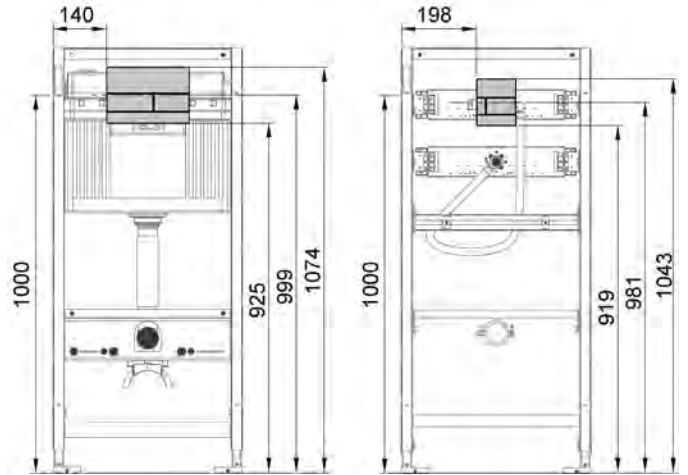

Toilet push plate (left) and urinal push plate (right) with module

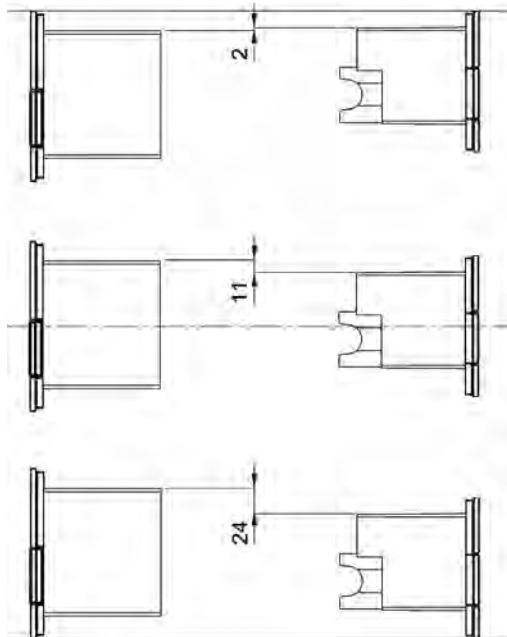

Toilet push plate (left) and urinal push plate (right):

- Installation top-aligned (figure top)
- Installation centred (figure centre)
- Installation bottom-aligned (figure below)

TECEsquare metal

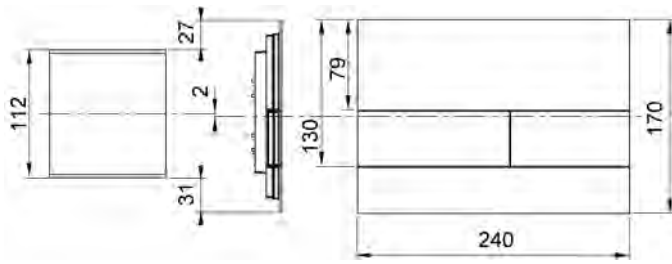

Dimensions of toilet push plate and bare-wall protection for vertical joint alignment

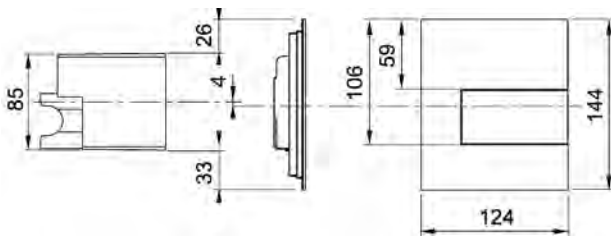

Urinal push plate and bare-wall protection for vertical joint alignment

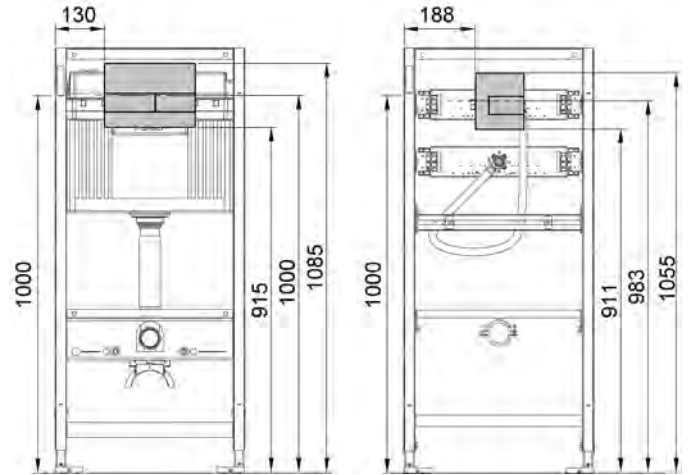

Toilet push plate (left) and urinal push plate (right) with module

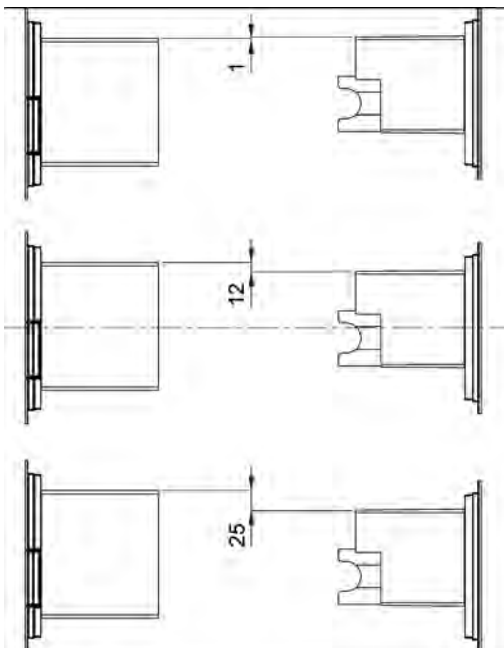

Toilet push plate (left) and urinal push plate (right):

- Installation top-aligned (figure top)
- Installation centred (figure centre)
- Installation bottom-aligned (figure below)

TECE push plates – installation dimensions

TECEplanus

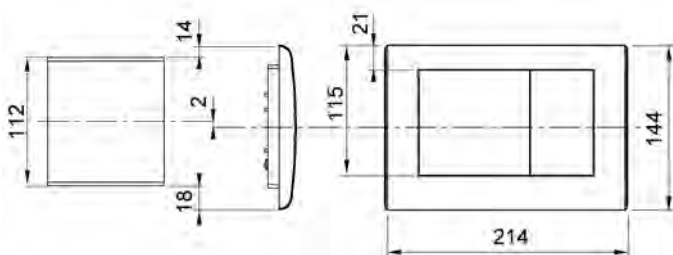

Dimensions of toilet push plate and bare-wall protection for vertical joint alignment

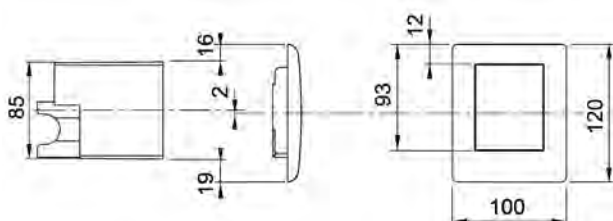

Urinal push plate and bare-wall protection for vertical joint alignment

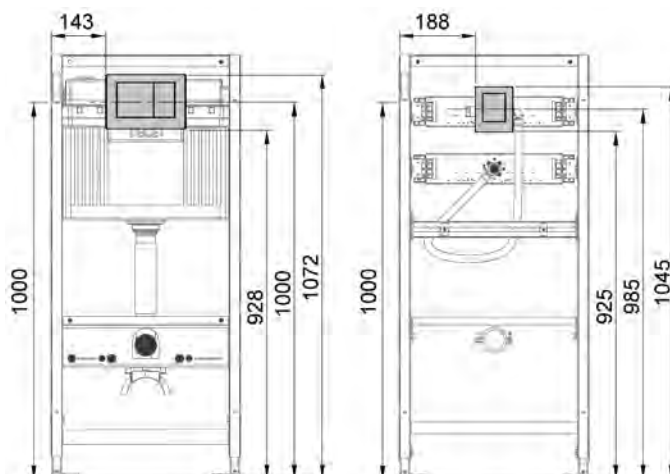

Toilet push plate (left) and urinal push plate (right) with module

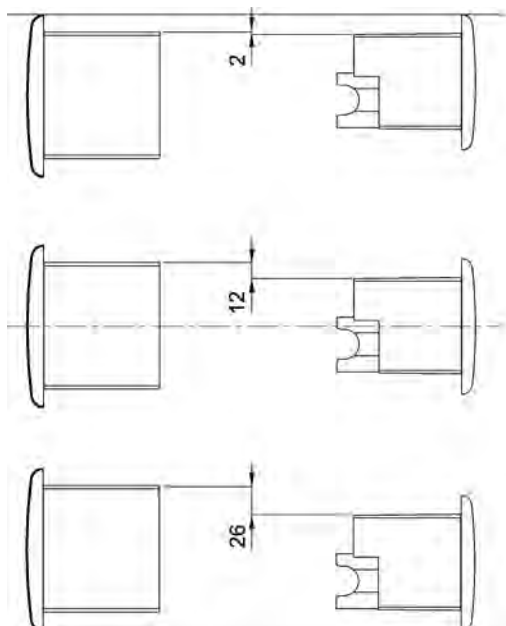

Toilet push plate (left) and urinal push plate (right):

- Installation top-aligned (figure top)
- Installation centred (figure centre)
- Installation bottom-aligned (figure below)



TECElux

TECElux
Technical Guidelines



Introduction	172
Design	172
Enhanced functions	173
Product range	174
TECElux terminal	174
TECElux modules	175
Upper glass push plates	176
Lower WC mounting glass plates	177
Accessories	177
TECElux as interface	178
Installation	179
Installation in a TECEprofil pre-wall	179
Installation as single module in front of a solid wall	179
Installation in floor-to-ceiling C-profile steel post-and-beam wall system	183
Installation in floor-to-ceiling steel post-and beam wall system with UA-profiles	183
Installation in wooden post-and-beam wall	184
Securing individual modules to the floor	185
Connection of the drain bend	185
Panelling and wall construction	185
Electrical connections	188
Fine installation	190
Lower WC mounting glass plate	190
M-Lift height adjustment	192
Upper glass push plate with manual operation	193
Upper glass push plate with electronic operation	194
Programming the TECElux sen-Touch electronics	197

TECElux – introduction

Introduction

The TECElux WC terminal places the technology in the wall, out of sight. An extremely flat glass plate closes off the inspection opening and conceals the cistern, water and power connections and, depending on the configuration level, an odour extraction or a height-adjustment for the ceramics.

Design

With its purest aesthetic design, TECElux blends into the architecture of every bathroom. The large glass surface of the terminal consists of two parts, but which give the impression of one unit. The glass plate acts as splash protection for the wall and thus permits a wall design which does not need tiles.

The toilet terminal can be combined with practically any ceramics and even with washlets.

TECElux has already been awarded several times for its intelligent combination of design and function.



reddot design award
winner 2011



NOMINIERT



DESIGN PLUS



Enhanced functions

Electronic actuation with "sen-Touch"



A sensor recognises when a person approaches the WC and then allows the flush buttons to light up. Actuation of the small or large flush volume occurs "touch-free" or by a light contact with the finger-tips. The electronic flush function is illuminated with energy-saving LEDs. For manual actuation, flushing is by using the buttons. These are available in a variety of colours and materials.

"ceramic-Air" air purification system



Odours are drawn away at the source and cleaned air is passed back into the room. There is no need for any extra fresh air which would first have to be warmed. The air purification system starts when a person approaches and stops automatically after a short run-on time. This prevents unnecessary power consumption. The activated charcoal filter has a long service life and only needs to be changed after about five years.

Height adjustment with "m-Lift"



TECElux offers the facility to adjust the height of the WC ceramics at any time, including after the module has been installed. There is no need to remove the ceramics to do this. The height can be customised through a stepless range of 8 cm using an adjustment spindle. In the process, the glass front moves at the same time, so that the overall optical impression is not affected by joints or gaps.

"smart-Connect" interface



Additional functions at the WC require space and often a power or additional water connection. Until now, the technology was simply bundled onto the ceramics and the water and power connections needed were installed in full view beside the WC. This is no longer necessary. The new WC terminal takes into account the aesthetic and functional aspects equally: TECElux incorporates the technology invisibly and safely in the pre-wall. The large inspection opening is covered by a flat glass plate and allows rapid access to the technology behind it at any time.

As an open interface between the WC functions and the bathroom architecture, the WC terminal can be combined with practically all ceramics and also with washlets.

Product range

TECElux terminal

A TECElux terminal always consists of:

- (A) one TECElux WC module
- (B) one upper glass push plate with actuation unit
- (C) one lower WC mounting glass plate with openings for the various power and water connections

(A) module



TECElux 100
9 600 100



TECElux 200
9 600 200

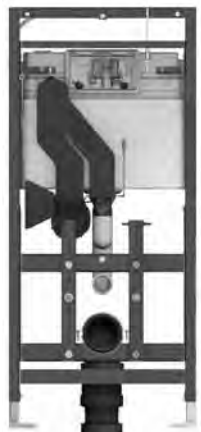

TECElux 400
9 600 400

(B) upper push plate



White buttons
9 650 000



bright chrome buttons
9 650 001



"sen-Touch"
9 650 002

(C) lower WC mounting glass plate



Standard WC
9 650 100

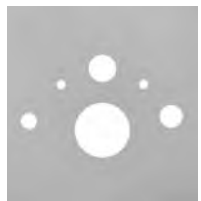

Washlet
9 650 101



Washlet toilet seat
9 650 102



TECElux modules

The TECElux module is a dry-wall element and is available in three different configuration levels. All modules consist of a self-supporting, sturdy mounting frame and the tried and tested TECE dual-flush system.

Further components in common:

- Sturdy, self-supporting mounting frame. All WC modules are statically self-supporting and can withstand a maximum load of 400 kg.
- Installation in C-profile, flush-mounted profile, TECEprofil or wooden post-and-beam wall, corner installation is also possible.
- For combination with the upper glass push plate and the lower WC glass plate.
- For standard ceramics with an attachment distance of 180 mm.
- Integral service brake makes it easy to adjust the module height.
- Adjustable supports for floor projections from 0 to 200 mm. For securing to the floor or to a TECEprofil rail.
- WC drain bend with adapter DN 90/100.
- Clearly visible metric labelling for setting-out.

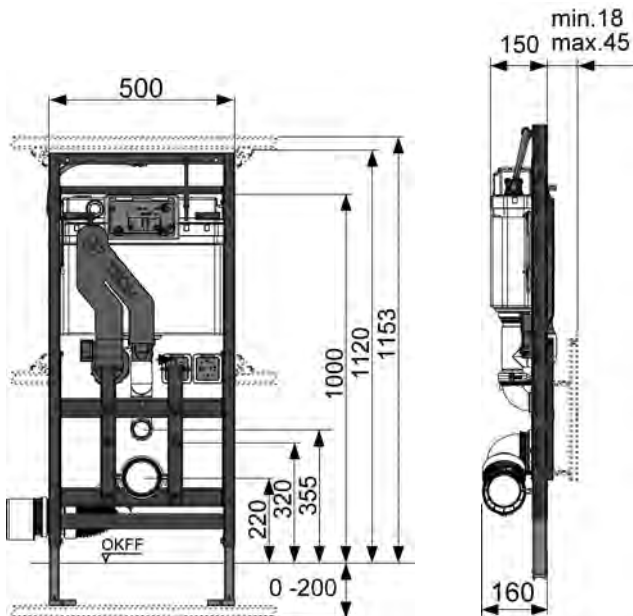

TECElux module - dimensions

Module TECElux 100

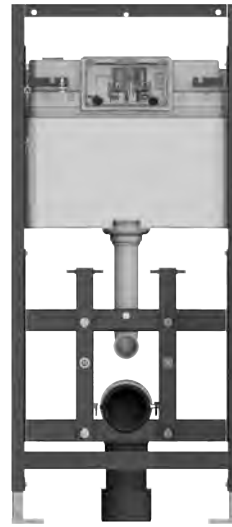

With TECE UP cistern and dual-flush technology.

The flush is actuated either mechanically using buttons or electronically by "sen-Touch".

The module can be optionally equipped with the "ceramic-Air" air purification system (only together with the "sen-Touch" upper glass push plate).

Item number 9 600 100

Module TECElux 200

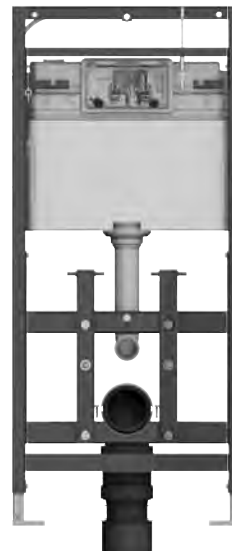

TECE UP cistern, dual-flush technology and manual height-adjustment.

The flush is actuated either mechanically using buttons or electronically by "sen-Touch".

The module can be optionally equipped with the "ceramic-Air" air purification system (only together with the "sen-Touch" upper glass push plate).

Item number 9 600 200

Module TECElux 400

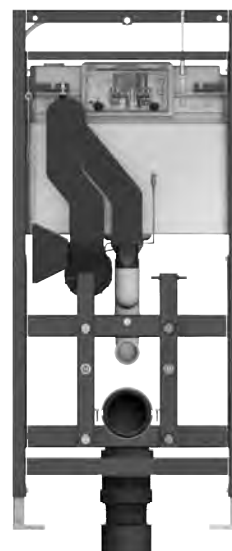

With TECE UP cistern, dual-flush technology, manual height adjustment and "ceramic-Air" air purification system.

Actuation of the flush is only done electronically (sen-Touch).

Item number 9 600 400

Technology of the module TECElux 400

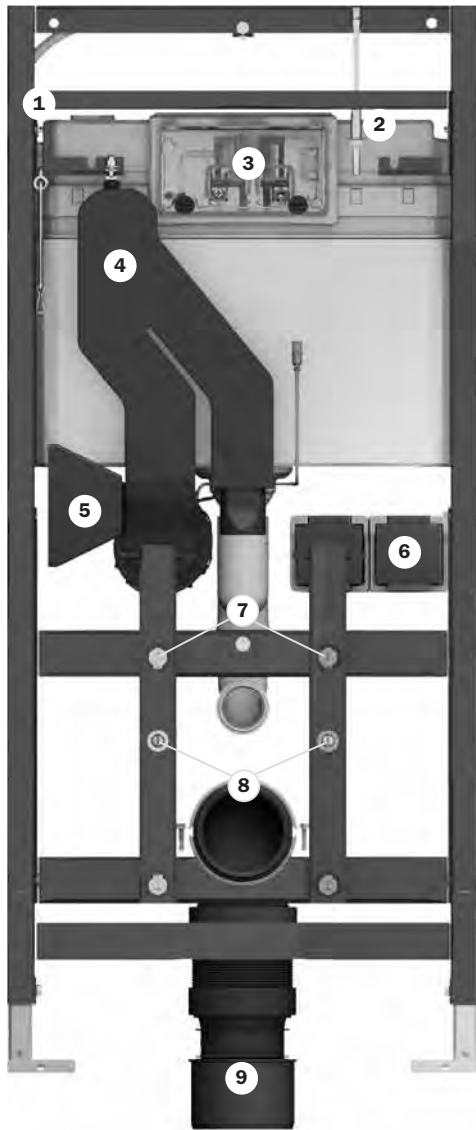

- 1) flexible water connection (concealed)
- 2) set screw for height adjustment
- 3) electronic dual-flush
- 4) "ceramic-Air" odour extraction
- 5) outlet opening for cleaned air, activated carbon filter
- 6) power connection, sockets*
- 7) height-adjustable support for the lower glass plate
- 8) retaining bolts for the ceramics
- 9) flexible drain bend

* not within the scope of delivery

Upper glass push plates



Upper glass push plates

Upper glass push plates with manual operation

Upper glass push plate for TECElux module with two spring-mounted push-buttons

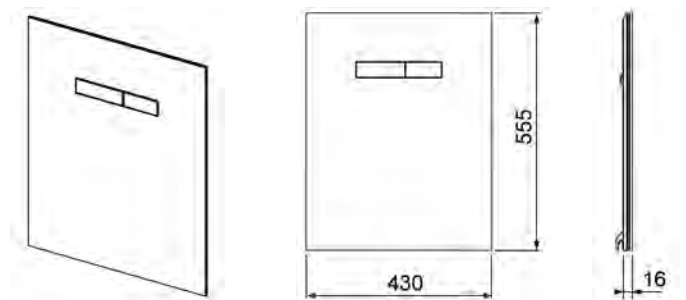

Including actuating rods and fastening material.
Dimensions: 430 x 555 x 16 mm

White glass version, white buttons:

Item number 9 650 000

White glass version, buttons bright chrome:

Item number 9 650 001

Upper glass push plate with electronic sen-Touch operation

Upper glass push plate for TECElux module with electronic sen-Touch push-buttons and fastening material.

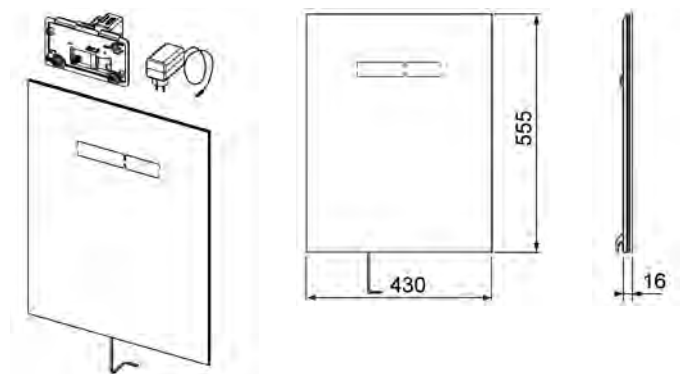

Incl. mains plug power supply unit (connection voltage 230 V) with dual-flush actuation motor.

Dimensions: 430 x 555 x 16 mm

Item number 9 650 002

Lower WC mounting glass plates

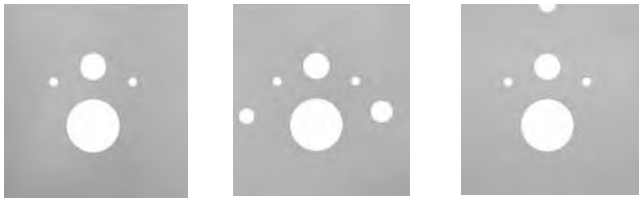

lower WC mounting glass plates

Lower mounting glass plate for standard WC

lower WC glass plate for combination with WC ceramics attachment distance of 180 mm.

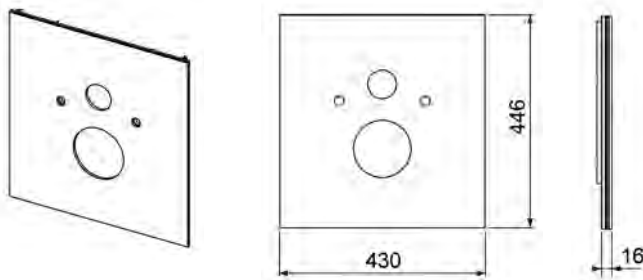

Incl. sound absorption set and glass protection caps
Dimensions: 430 x 445 x 16 mm

White glass version
Item number 9 650 100

Lower mounting glass plate for washlet

lower WC glass plate for combination with TOTO Neorest washlet or Geberit AquaClean 8000/8000 plus.

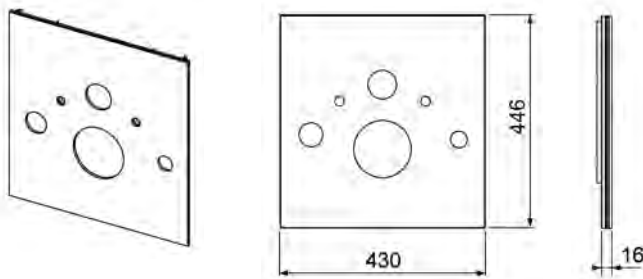

Incl. sound absorption set, glass protection caps and hose for connection to a washlet armoured hose.
Please use washlet connection set (9 660 001).
Dimensions: 430 x 445 x 16 mm

White glass version
Item number 9 650 101

Lower mounting glass plate for washlet toilet seat

Lower WC glass plate for combination with washlet toilet seat TOTO Washlet.

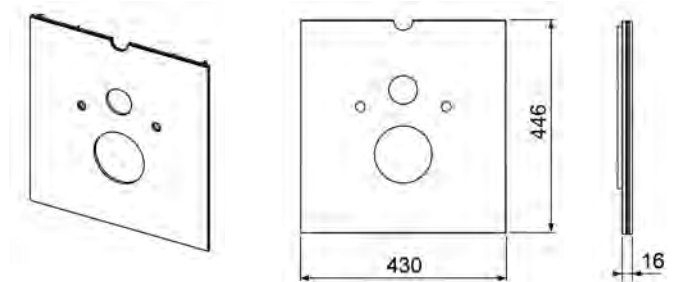

Incl. sound absorption set, glass protection caps and hose for connection to a washlet armoured hose.
Please use washlet connection set (9 660 001).
Dimensions: 430 x 445 x 16 mm

White glass version
Item number 9 650 102

Accessories

ceramic-Air odour extraction upgrade set

Upgrade set for retrofitting of ceramic-Air odour extraction for WC terminal TECElux 100 or TECElux 200.

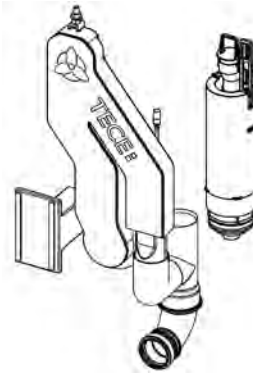

Upgrade set consists of:

- odour extraction housing incl. fan and air outlet
- filter cartridge
- fastening materials
- flush pipe with connection for odour extraction
- drain valve

Item number 9 660 000

Connection set for washlet



Connection set consisting of:

- long armoured hose with connection for TOTO Neorest or TOTO Washlet

Item number 9 660 001

Connection set for electrical connection

For the fixed electrical connection of the sen-Touch glass plate in protected zone II.

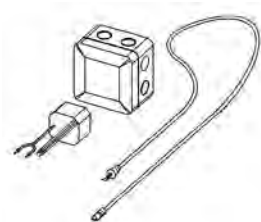

Connection set consisting of:

- back box protection class IP 44
- transformer 230 / 12 V
- sen-Touch connection cable

Item number 9 660 002

TECElux as interface

Connection of a standard WC to a TECElux module

The following items are required for connection of a standard WC:

- standard WC ceramics
- TECElux module (9 600 100, 9 600 200 or 9 600 400)
- WC mounting glass plate (9 650 100) with sound absorption set

Connection of a washlet to a TECElux module

The following items are required for connection of a washlet:

- washlet TOTO Neorest or Geberit AquaClean 8000/8000 plus
- TECElux module (9 600 100, 9 600 200 or 9 600 400)
- WC mounting glass plate (9 650 101) with sound absorption set and armoured connecting hose (see illustration below)
- connection set (9 660 001) only for TOTO Neorest

Connection of a washlet toilet seat to a TECElux module

The following items are required for connection of a washlet toilet seat (TOTO Washlet GL or similar):

- Washlet toilet seat TOTO Washlet
- TECElux module (9 600 100, 9 600 200 or 9 600 400)
- WC mounting glass plate (9 650 102) with sound absorption set and armoured connecting hose (see illustration below)
- connection set (9 660 001)



Armoured connecting hose

Installation

Universal module technology is applied with the TECElux modules as well. This also means an extended application area for installation:

- in a TECEprofil pre-wall
- in front of a solid wall
- in a C-profile wall
- in a UA-profile wall
- in a wooden post-and-beam wall

Installation in a TECEprofil pre-wall



Installation in a TECEprofil pre-wall

The simple installation technique permits speedy and safe working. The universal modules can be quickly and safely installed in a TECEprofil wall with only a few hand movements:

- Release the service brakes
- Place the module feet on the lower continuous profile brace
- Pull out the module; the service brake is on hard enough to carry the weight of the module and to prevent any sliding back
- Secure the module with the angle brackets to the upper profile brace
- Reapply the service brakes
- Tighten the module feet – only by hand!
- Installation of the middle profile brace

As well as installation in a pre-wall, the module can also be inserted in a free-standing wall made up of TECEprofil system components:

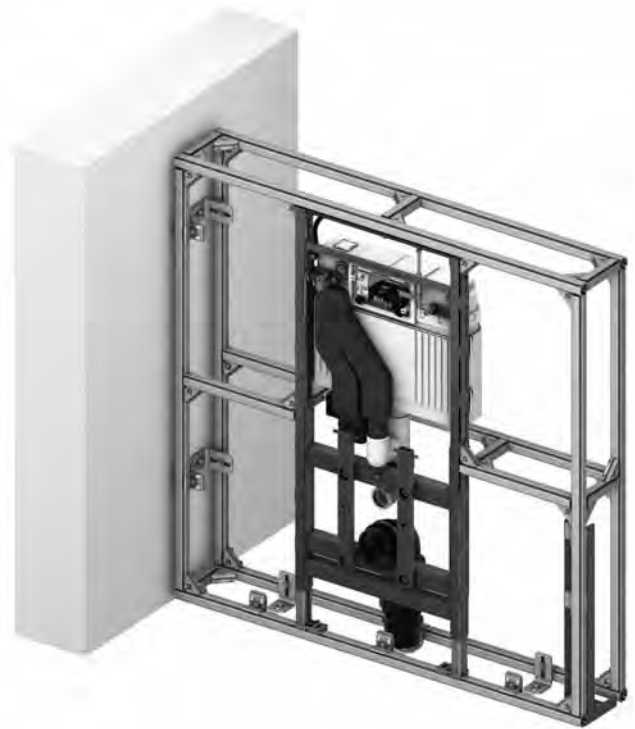

Installation in a free-standing TECEprofil wall

Installation as single module in front of a solid wall

The TECEprofil universal modules are also suitable for individual installation. Appropriate fastenings are offered for the different installation situations. The universal modules are structurally designed in such a way that in the standard situation, they only need to be secured at four points to a structural shell able to take the load. The fastening material provided with the mounting devices is suitable for installation on solid walls. When securing to lightweight partition walls, wall plugs suitable for hollow walls must be used. In addition, reinforcement of the lightweight partition wall must be provided at the securing points. The procedure must be agreed with the dry-wall builder.

The installation instructions of the dry-wall system being used must be respected.

TECElux – installation

Individual module installation with height-adjustable universal attachments (Item No. 9 380 000):



Individual module installation with height-adjustable universal attachments

The universal module is placed directly against the wall. The universal attachments can be used to adjust the depth to the wall. The module height is adjusted using the pull-out module feet. The service brake prevents the module from sinking. In this way, the module can be exactly positioned before the module feet and the universal attachments are secured to the structural shell.

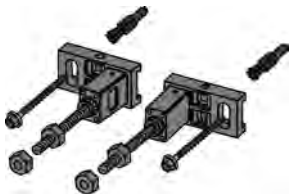

Universal attachment 9 380 000

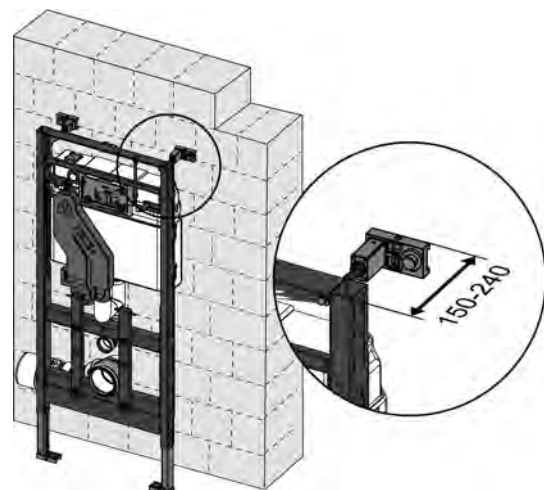

Adjustment range of the universal attachment 150 – 240 mm

Individual module installation with height-adjustable module attachment (Item No. 9 380 002):



Individual module installation with height-adjustable module attachment

With the height and depth adjustable module attachment, variable bearing structure heights from 1160 mm to 1300 mm can be achieved. This allows the height of the module to be adapted, for example to the height of an existing tile pattern.

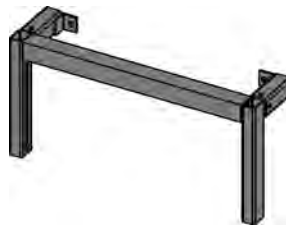

Universal attachment 9 380 002

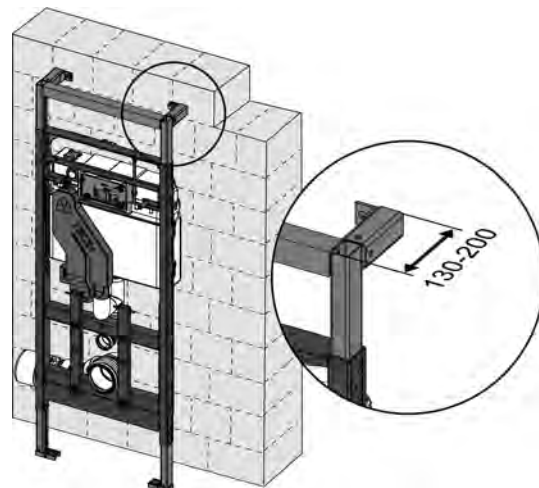

Adjustment range of the height-adjustable module attachment 130 – 200 mm

Installation with module attachment for corner of wall mounting (Item No. 9 380 004)

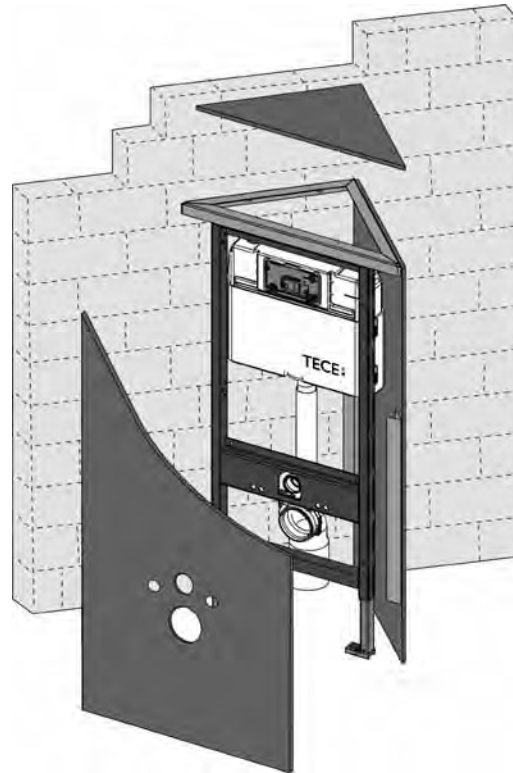

Individual module installation with module attachment for corner of wall mounting

Using the module attachment for corner of wall mounting, the TECEprofil universal module can be secured at an angle of 45° to the wall of the structural shell. The attachment here is screwed to the structural shell at only one of the arms. There are two angle plates provided for installation of the panelling. The short arm length of the attachment permits layouts with a footprint of only 0.14 m².

Installation of module attachment for corner of wall mounting

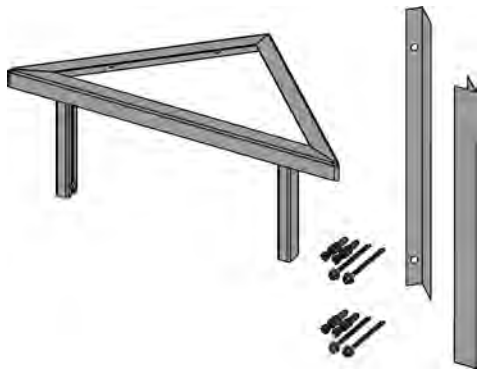

Module attachment for corner of wall mounting 9 380 004

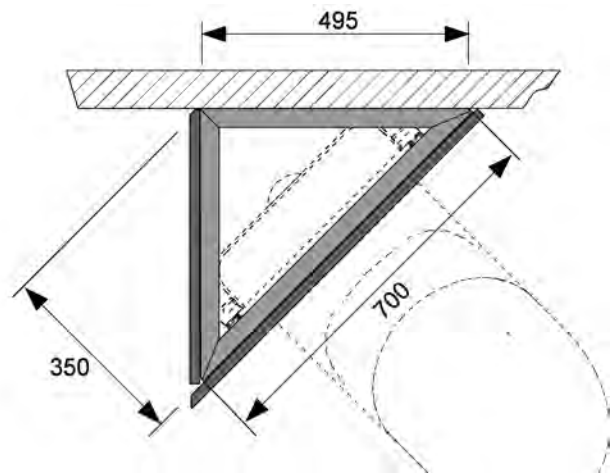

Dimensions of module attachment for corner of wall mounting

TECElux – installation

Installation of module attachment for variable corner mounting (Item No. 9 380 003)



Module attachment for variable corner mounting 9 380 003



Installation of module attachment for variable corner mounting

The universal module can be secured directly to the structural shell with corner attachments. The corner attachment permits parallel installation of a TECEprofil brace. With two TECEprofil brace, one angle bracket and one corner angle bracket, a storage shelf can be constructed. Installation in a corner takes up very little space. The attachment set has an arm length of only 49.5 cm. The shelf depth from the front edge of the module to the corner is only 35 cm. Despite the minimal installation depth, it is possible to fit a DN 100 drain pipe behind a WC module.

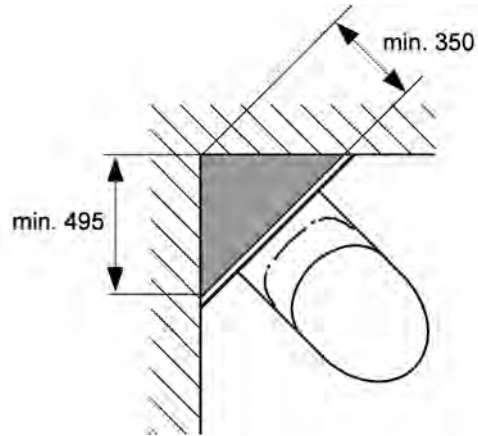

Dimensions of module attachment for variable corner mounting

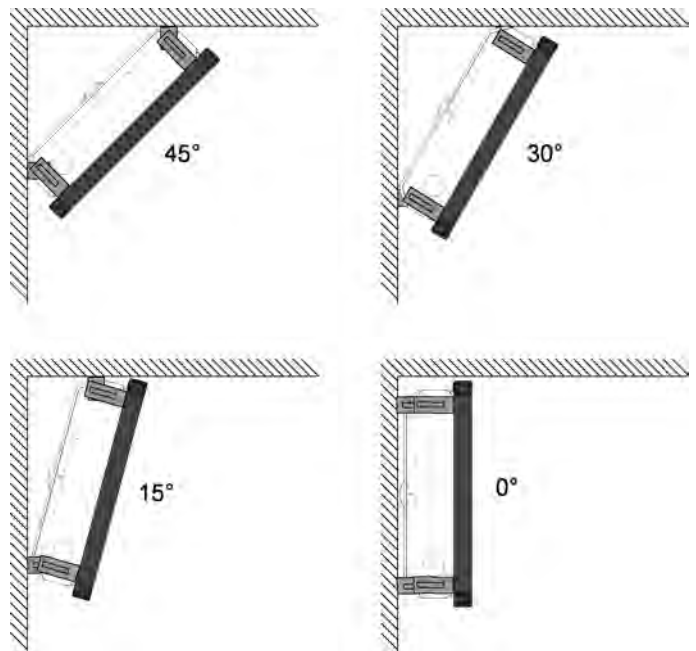

Example installation of module attachment for variable corner mounting

Installation in floor-to-ceiling C-profile steel post-and-beam wall system



Installation in a floor-to-ceiling C-profile steel post-and-beam wall system

In double post-and-beam walls, the individual stud rows must be firmly connected to each other according to DIN 18183. To achieve this, 30 cm anchors are screwed in between the C-profiles. Two reinforcing anchors are installed directly above the universal module. The module is screwed to the wall profile at each of four points using the self-tapping screws provided. The module feet are in the front horizontal C-profile and are screwed to the floor using plugs.

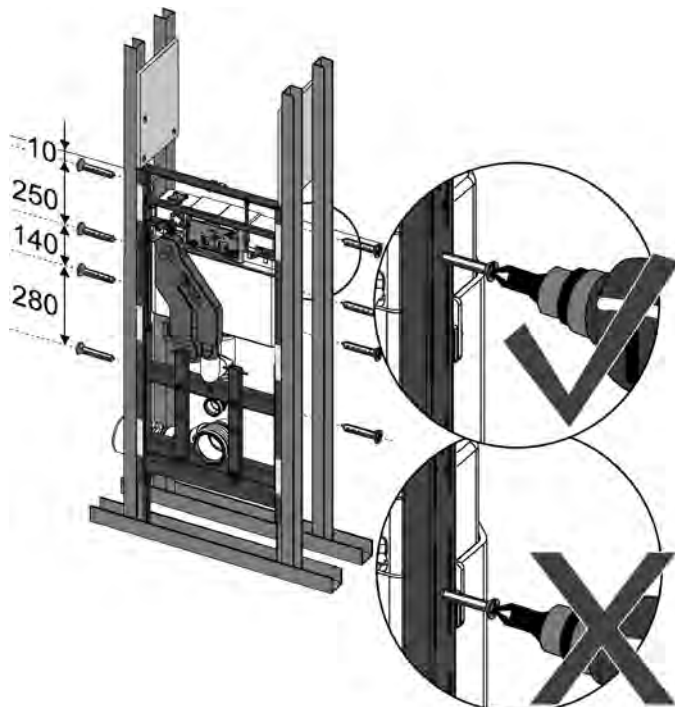

Securing the module during installation in a floor-to-ceiling C-profile steel post-and-beam wall system

The installation instructions of the dry-wall system being used must be adhered to.

Installation in floor-to-ceiling steel post-and-beam wall system with UA-profiles



Installation in a floor-to-ceiling UA-profile steel post-and-beam wall system

If particularly wide or high walls have greater rigidity, UA-profiles according to DIN 18182 part 1 can be used instead of C-profiles. This measure is useful with universal modules for WC and bidet.

For a disabled toilet facility, the front and rear braces should be exclusively UA-profiles, for reasons of rigidity. A disabled and senior citizen toilet facility in the public sector is constructed in accordance with DIN 18040-1.

When securing a TECElux module 200 or 400, two holes (8 mm) must be drilled on each side of the TECElux module frame, 15 mm apart and 390 mm below the top edge of the module.

The module is then secured to the UA-profile using the mounting set (9 380 006).

Installation in wooden post-and-beam wall

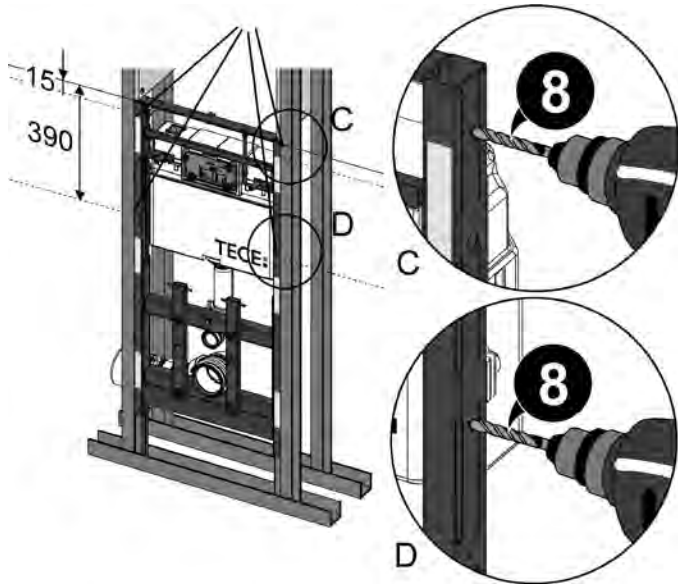

Drilling the mounting holes for securing the module

Installation in a wooden post-and-beam wall

As well as in steel post-and-beam wall systems, the module can also be installed in wooden post-and walls according to DIN 4103-1. To do this, the frame is secured to the vertical wooden braces using special wood screws (Item No. 9 380 005).

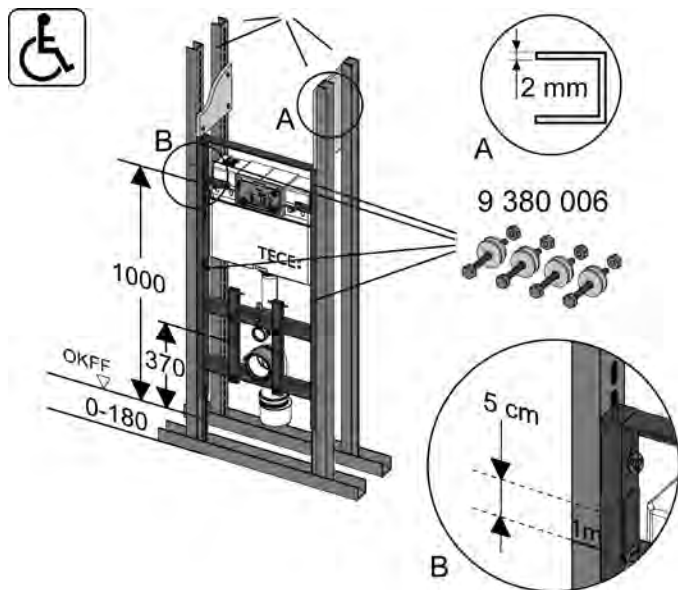

Securing the module during installation in a floor-to-ceiling UA-profile steel post-and-beam wall system

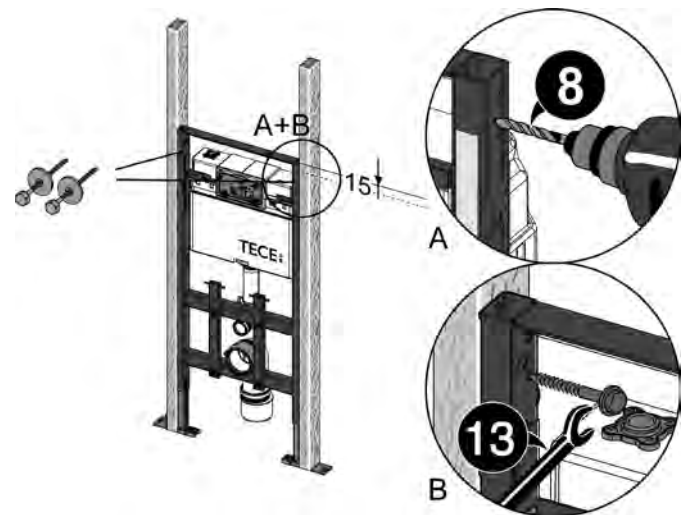

Securing the module during installation in a wooden post-and-beam wall

When securing a TECElux module 200 or 400, two holes (8 mm) must be drilled for this purpose on each side of the TECElux module frame, 15 mm apart and 390 mm below the top edge of the module. The module is then secured to the wooden post-and-beam structure.

Securing individual modules to the floor

The feet of the universal modules - if they are not screwed to a tube section – are secured to the unfinished floor using the screws and plugs provided. Here the plugs must be anchored in screed over their complete length.

The compression strength of the screed must be at least 5 N/mm². If the installation is on a wooden floor, secure fixings into the joists must be ensured.

Connection of the drain bend

A transition to sliding socket joint DN 90 or DN 100 can be made with the drain bend. A welded connection is possible with the DN 90 connecting piece of the flexible drain bend (only for the modules with m-Lift function TECElux 200 and 400).

The flexible drain bend can be installed horizontal to either side or vertical downwards.

For horizontal installation, the fastening clamp is screwed directly to the module frame, for vertical installation the clamp must be secured in the wall.

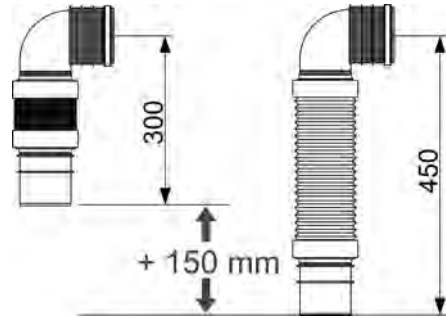

Flexible elongation

If the flexible drain bend is used, a cleaning coil must never be inserted because this could damage the flexible part.

Panelling and wall construction

The pre-wall is lined with the standard damp-area panels (e.g. TECEprofil panels 9 200 000), at least 18 mm or 2 x 12.5 mm. To do this, wide bare-wall protection system must be installed.

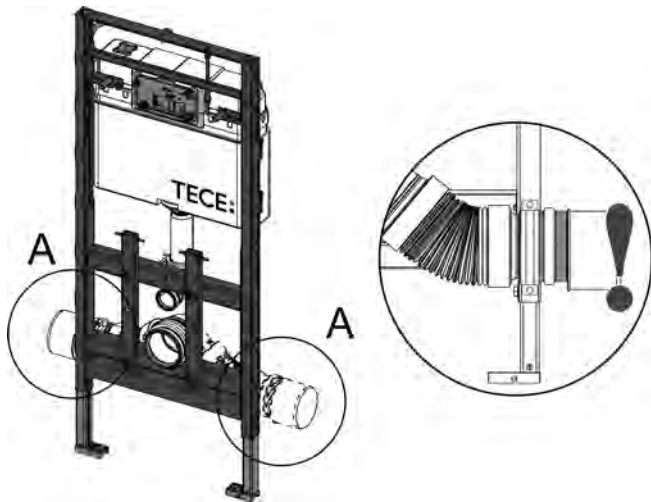

Horizontal installation of the flexible drain bend (TECElux 200 and 400)

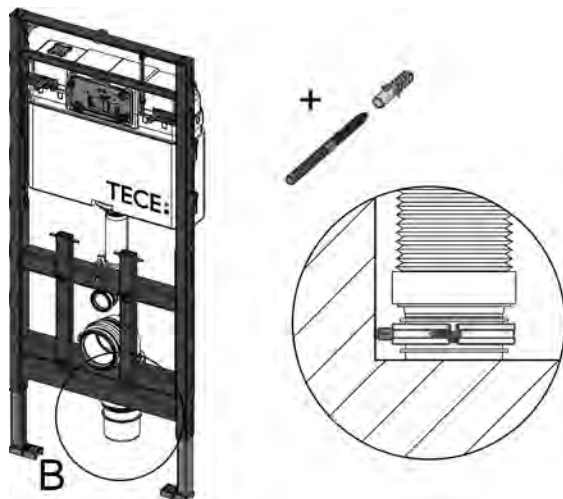

Vertical installation of the flexible drain bend (TECElux 200 and 400)

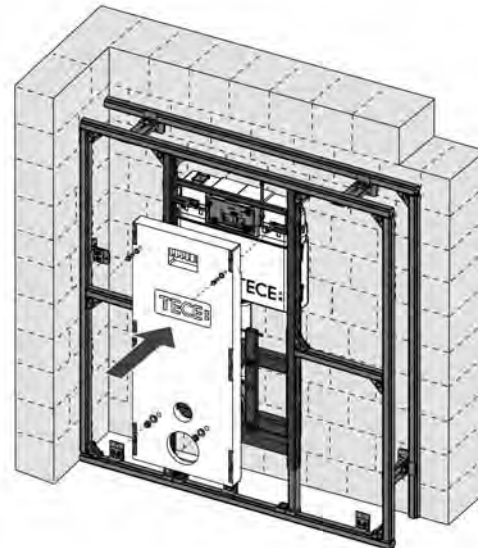

Secure bare-wall protection system on the module

TECElux – installation

The exact dimensions of the bare-wall protection system are transferred onto the plasterboard.

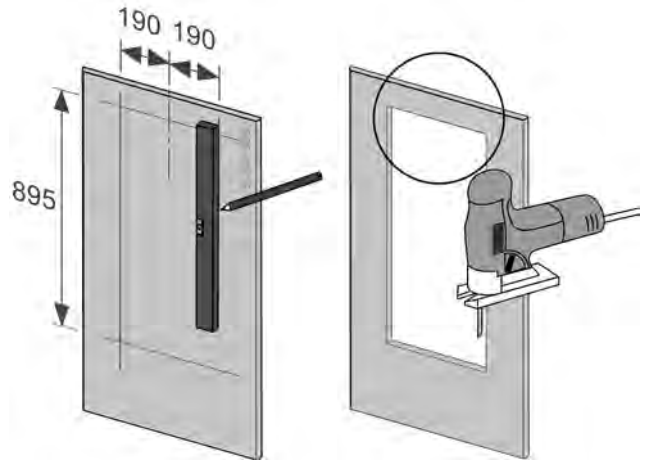
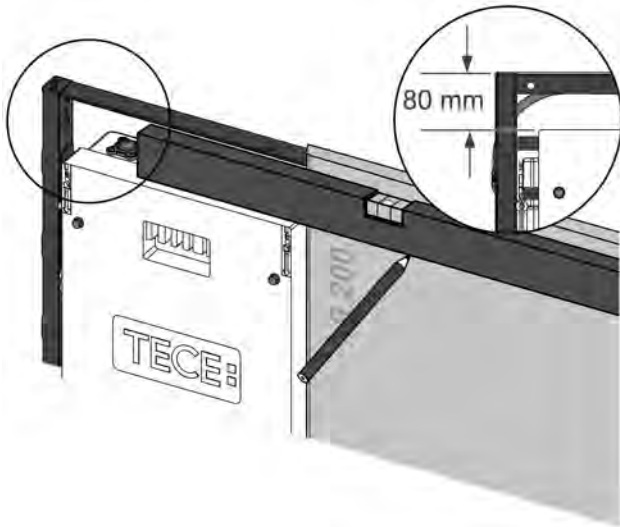

Cut the wall cut-out

To ensure the height adjustment of the two modules TECElux 200/400, the module frame must not be drilled in certain areas. These are identified by 2 x 3 stickers on the frame.

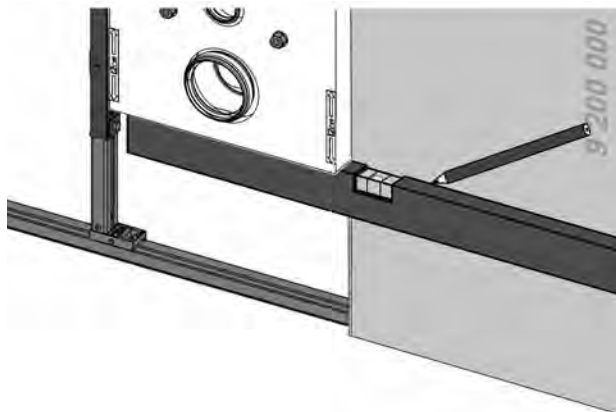

Transfer the upper and lower markings onto the panel

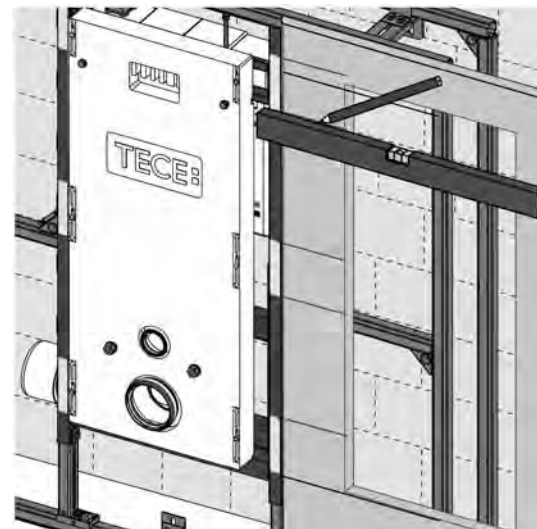

Transfer the marks to the plasterboard

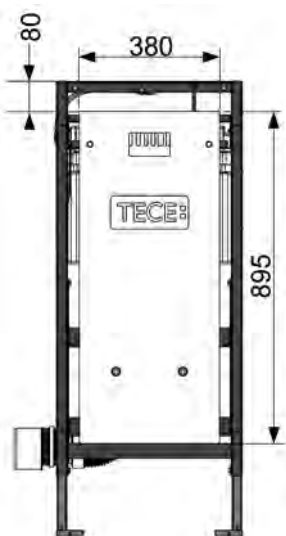

Measure the bare-wall protection system or wall cut-out

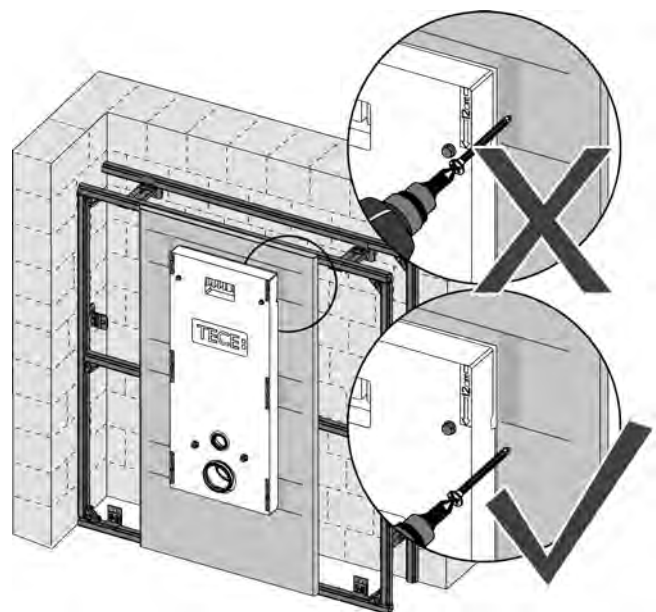

Do not drill the marked areas

The joints are filled after the panels have been secured.

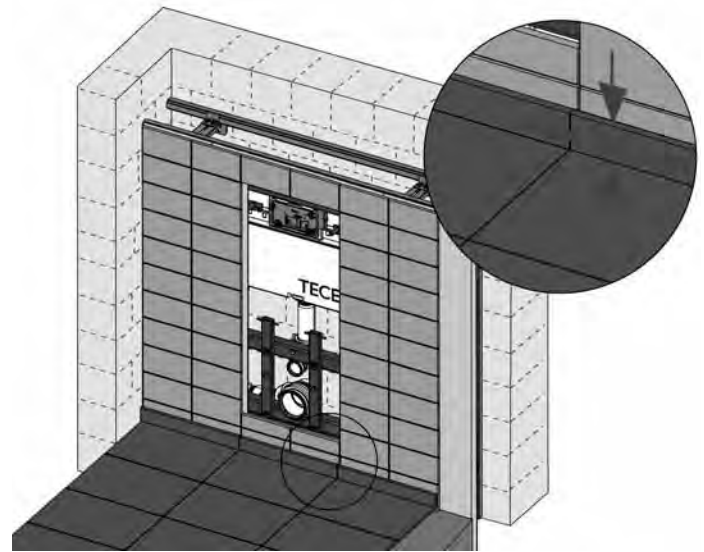
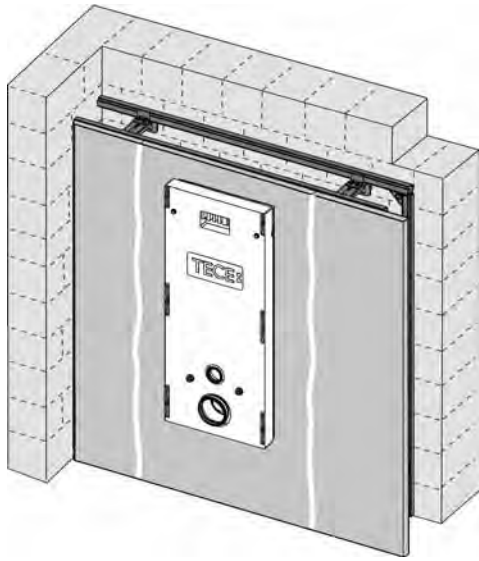

Base height max. 50 mm

Fill edge joints of the plasterboard.

When tiling the wall, care must be taken that the wall covering is applied up to the bare-wall protection system without any gap.

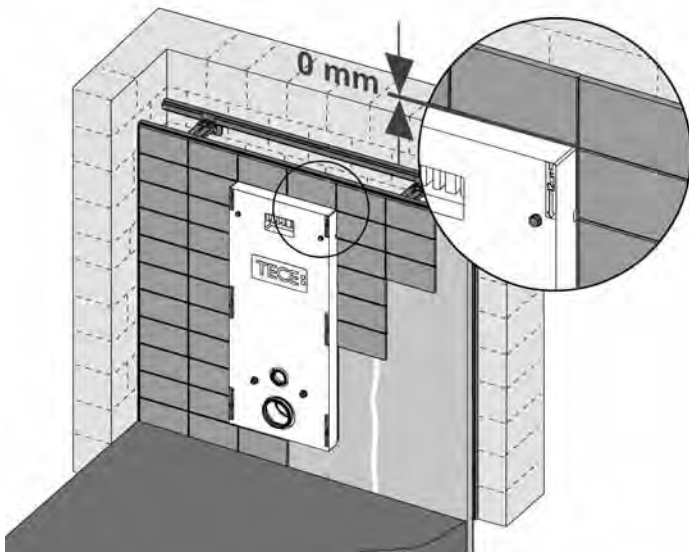

Apply the wall covering

When tiling the floor, care must be taken that the height of the base must be no more than 50 mm, otherwise the lower glass mounting plate can collide with the base.

TECElux – installation

Electrical connections

Electrical requirements and protected zones in the bathroom

For all spaces which are used by people for bathing and/or showering, and in which bath and/or shower equipment is permanently located, the provisions apply of DIN VDE 0100-701 (VDE 0100 part 701): 2010-08.

Among these spaces are also rooms with prefabricated bath, shower or whirlpool equipment, as well as shower corners without a shower tray (e.g. with TECEdrainline shower channels). The standard does not apply to spaces with showers which are only used in an emergency, for instance emergency showers in laboratories.

The protected zones in these rooms are divided into three classes:

Zone 0 – is the inside of the bath tub or shower tray. No source of power is permitted in this zone.

Zone 1 – is bounded by

- the upper surface of the finished floor and the horizontal plane at the height of the highest permanently installed shower head or water outlet or the space up to 225 cm vertically above the finished floor,
- the outside edges of the bath tub or shower tray,
- the inner edges of the walled tub,
- the region a distance of 120 cm from permanently installed shower head or water outlet.

The space underneath the bath tub and/or shower tray also belongs to this zone. No source of power is permitted in this zone either.

Zone 2 – is bounded by

- the upper surface of the finished floor and the horizontal plane at the height of the highest permanently installed shower head or water outlet or the space up to 225 cm vertically above the finished floor,
- the region a distance of 60 cm from zone 1.

For showers without a shower tray, zone 2 does not apply.

Zone 3 – is bounded by

- the region a distance of 240 cm from zone 2.

No protected zones are specified for washstands, WCs and similar equipment.

A TECElux module with an electrical connection (for the sen-Touch push plate or connection for a washlet or washlet toilet seat) may therefore only be installed in zones 2, 3 and above.

Installation of TECElux in zone 2

When installing an electrical connection in zone 2, the work must be done using the connection set for a fixed electrical connection (9 660 002).

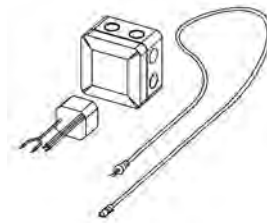

Connection set for electrical connection 9 660 002

Installation of TECElux in zone 3 and other zones

To easily achieve an interface to the power supply, it is sufficient during the shell construction stage to include a surface-mounted socket (protection class IP 44) in the wall (see manufacturer's installation instructions, Legrand, Jung, Merten, Busch Jäger, etc.). During the fine installation the fitter can make the connection to the electronic push plate very easily with a mains plug power supply unit. If a washlet is planned, another socket must be installed for the power supply of the WC.

The dimensions for positioning the socket(s) are given in the illustration below:

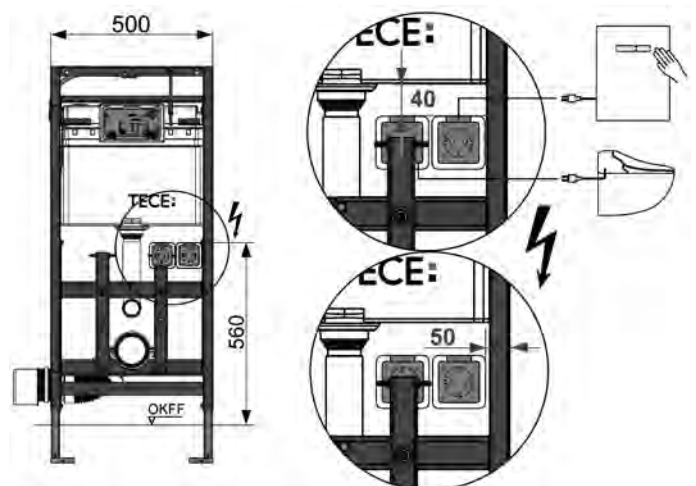

Positioning the socket(s) for the TECElux module



Installation of a TECElux module in protected zone 2



Installation of a TECElux module in protected zone 3

Fine installation

The detail installation for the TECElux terminal is done in this sequence:

- lower glass mounting plate
- height adjustment if applicable
- upper glass push plate

lower WC mounting glass plate

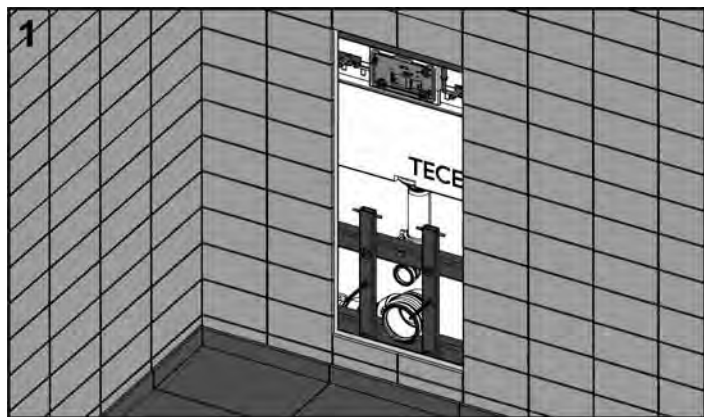

Remove the bare-wall protection system.

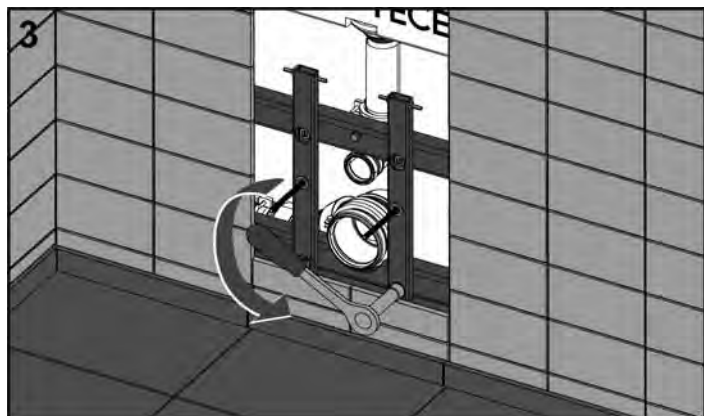
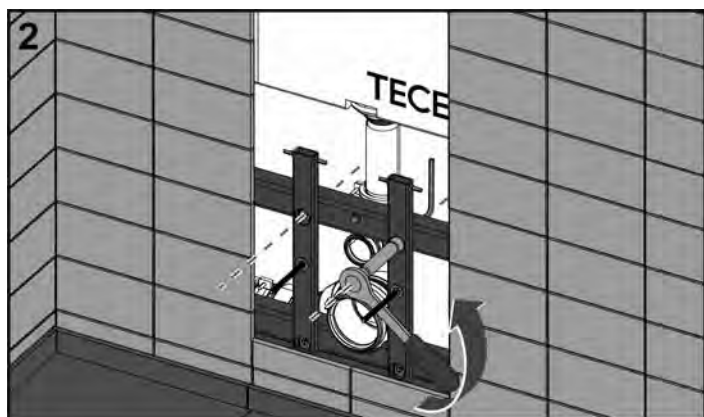

Undo the securing nuts of the height adjustment (4 x).

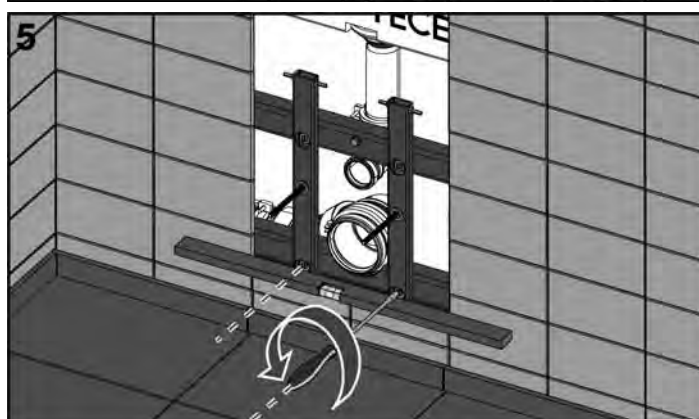
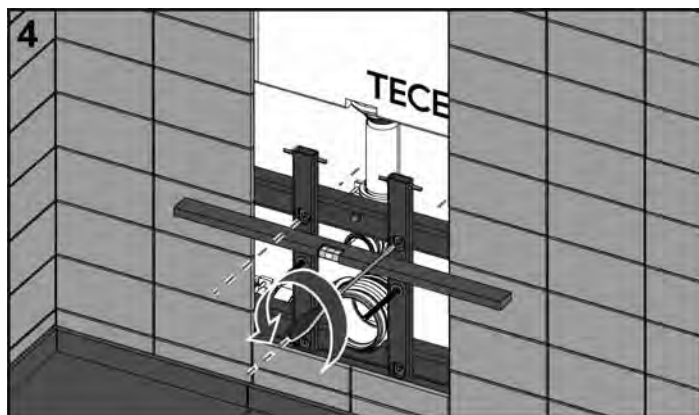

Adjust the support of the lower glass plate at the top and bottom so that it is flush with the wall by using a screwdriver to screw the four threaded rods in or out.

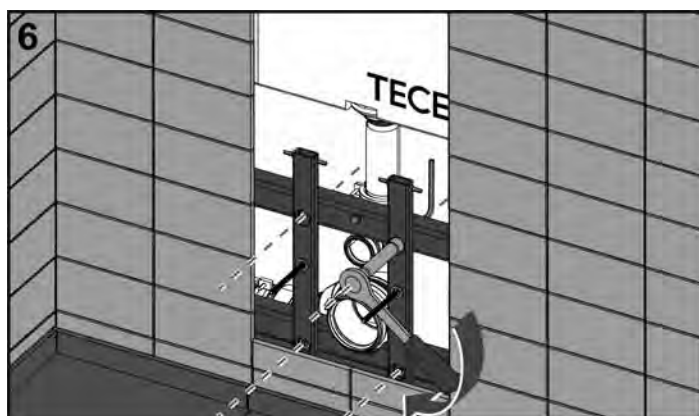

Then secure the threaded rods at the rear (M 10 spanner) and tighten the lock nuts.

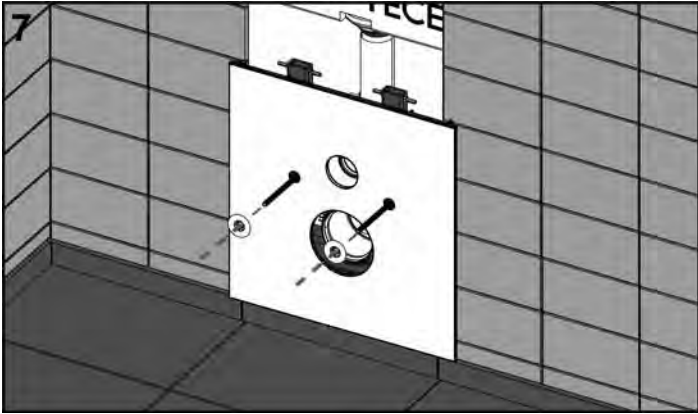

Put on the lower glass mounting plate and push on the two glass protection caps.



Align the glass plate and install the WC ceramics.

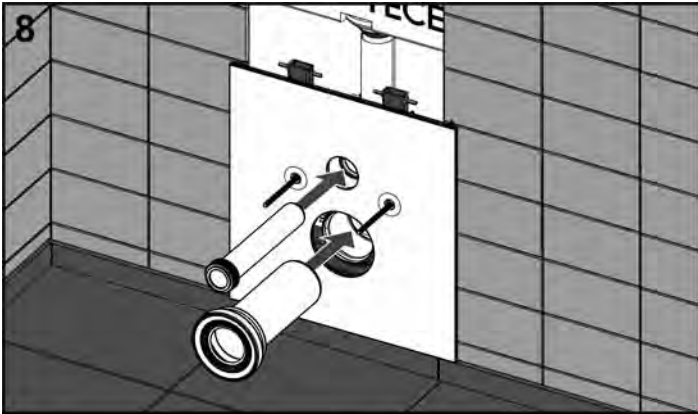

Cut the WC connection set to length and secure it.



Cut off any excess sound insulation material.

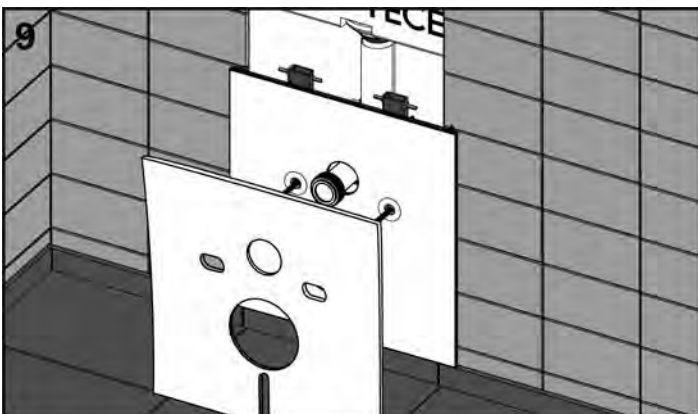

Put the sound absorption set in position.

M-Lift height adjustment

On modules with the manual height adjustment "m-Lift", the adjustment is made using the easily accessible regulating screw (A).

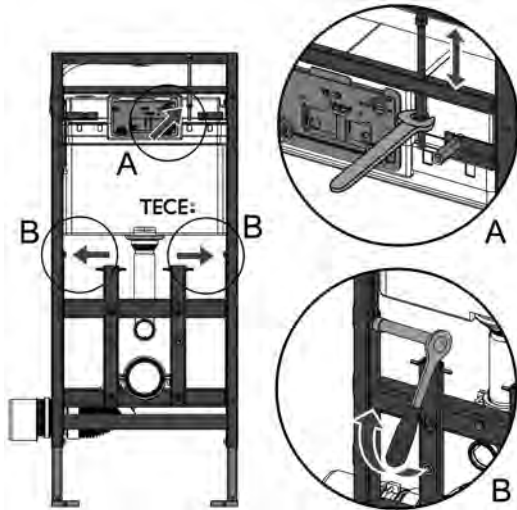

If a WC bowl is already installed, the nuts securing it should be loosened slightly. In the first stage, the two side retainers must be released (B).

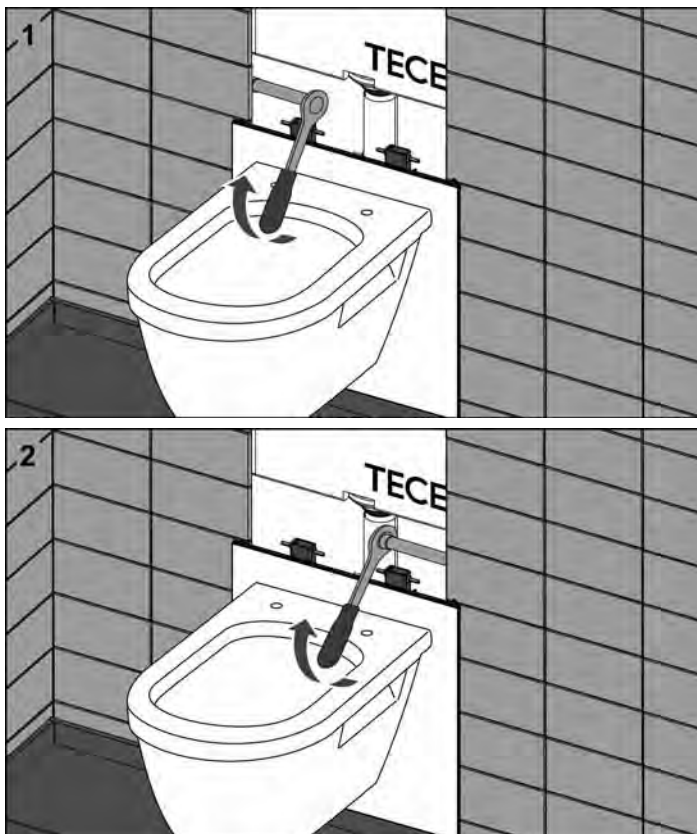

The height adjustment is then made using the regulating screw. "Fast adjustment" can also be made by lifting the ceramics slightly. Fine adjustment is then made using the regulating screw.

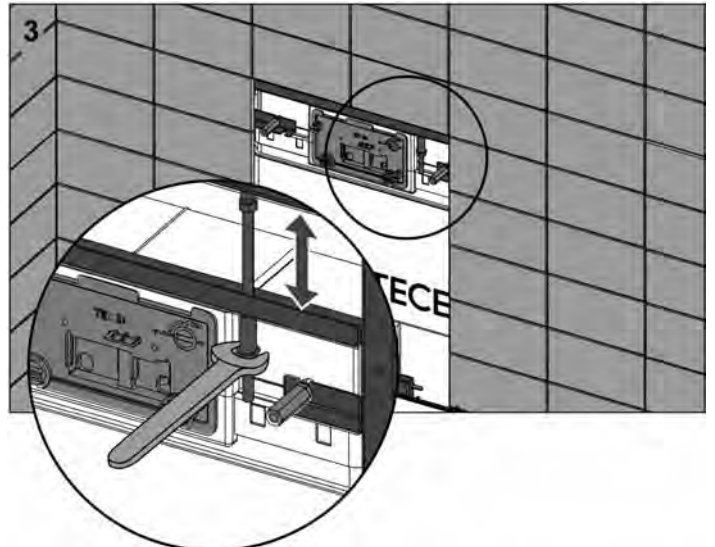

On the TECElux modules 200 and 400, the height can be adjusted by 20 mm downwards or 60 mm upwards – compared to the factory setting of the module frame.

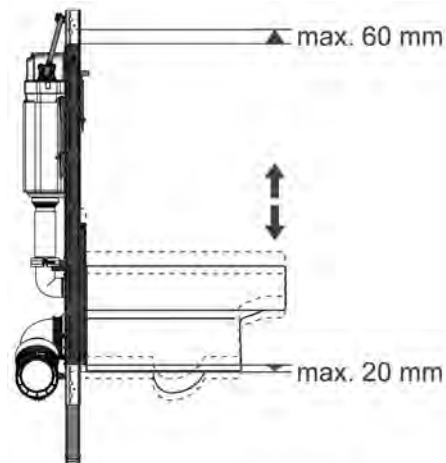

After the height has been adjusted, the two screws at the sides must be tightened again to lock the assembly.



Upper glass push plate with manual operation

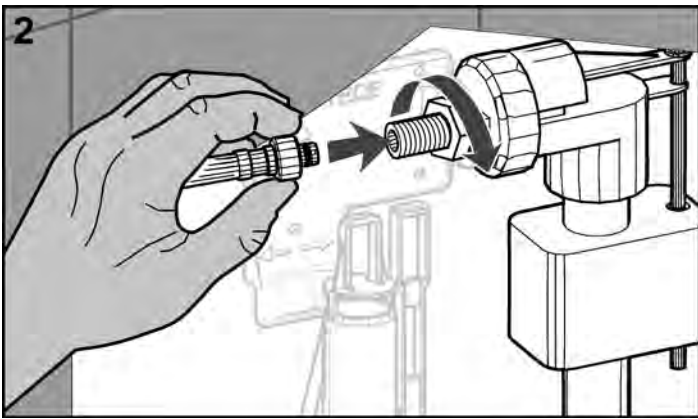
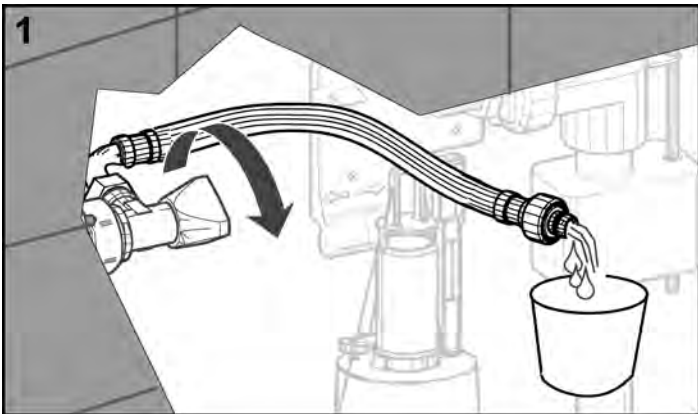

Flush the connection pipes sufficiently and screw onto the filling valve.

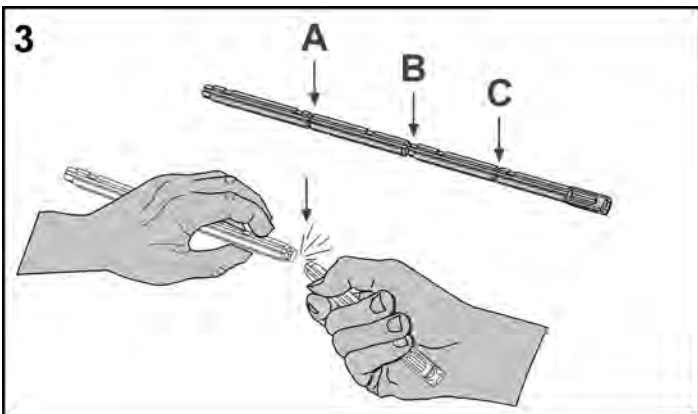

Trim the actuating rod to length.

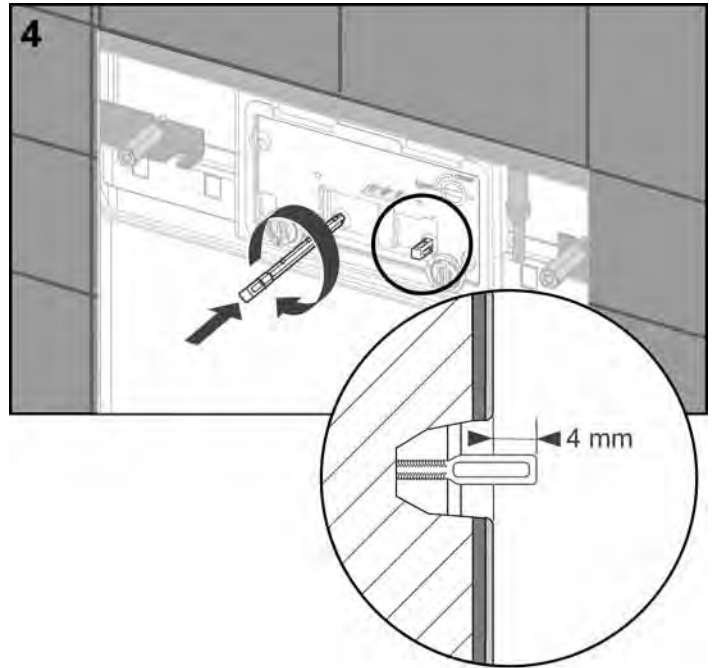

Screw in the actuating rod – 4 mm from wall surface.

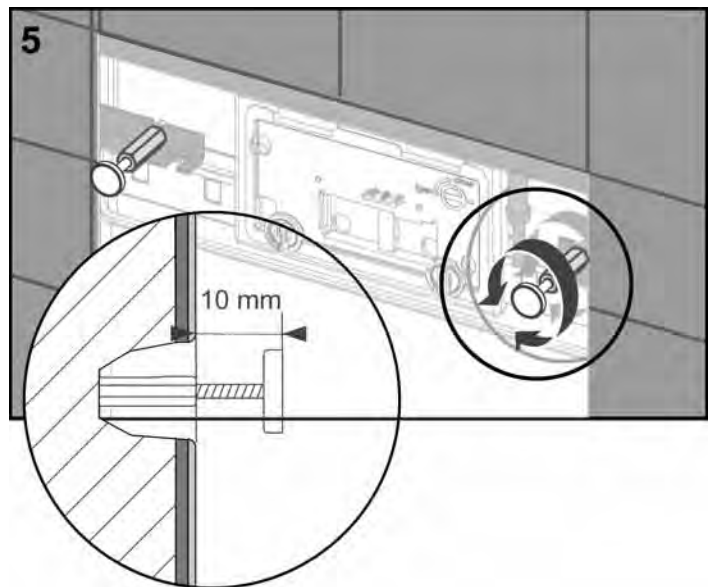

Screw in both securing magnets – 10 mm from wall surface.

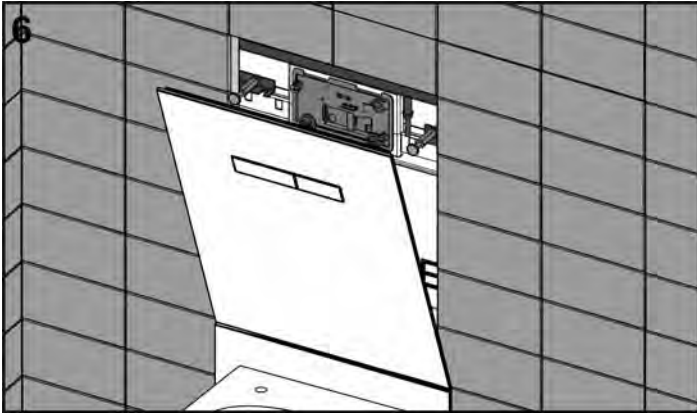

Insert the upper push plate into the brackets.



Fill the gap between the ceramics and the glass plate with permanently flexible joint sealant.

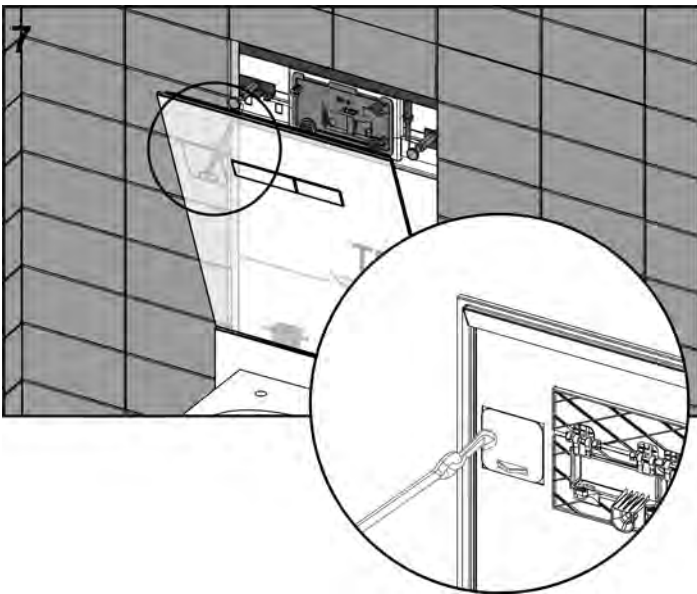

Secure the glass plate with security tape (engage the snap hooks into the eyes).

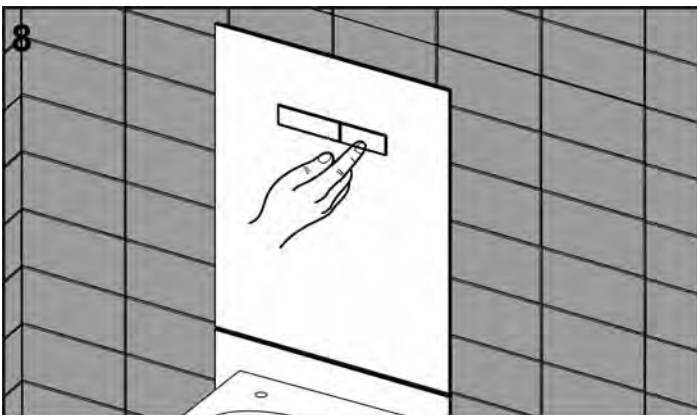

Fold the glass plate upwards and check the operation of the flush.

Upper glass push plate with electronic operation

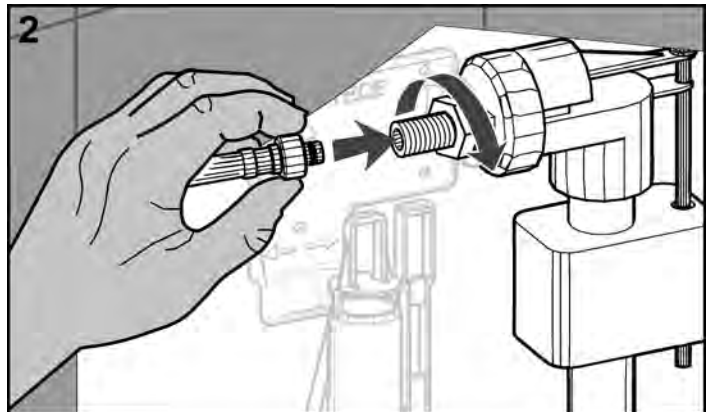
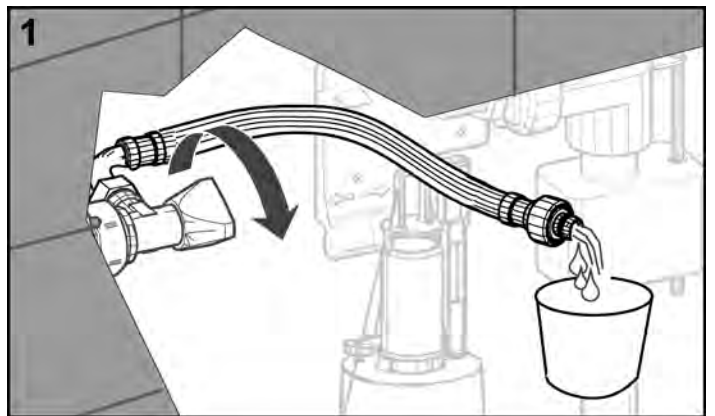

Flush the connection pipes sufficiently and screw onto the filling valve.

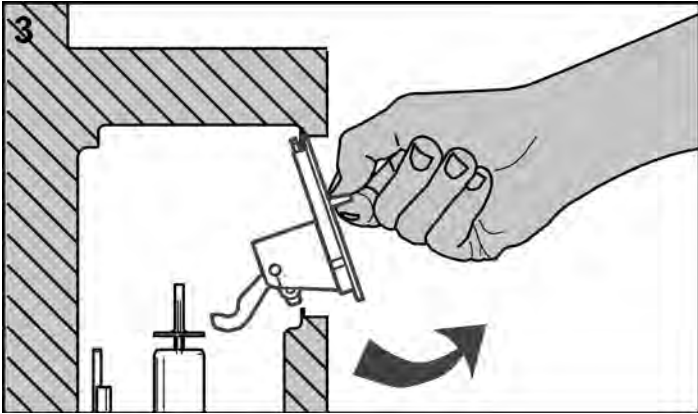

Take out the splash guard with mechanical actuation block.

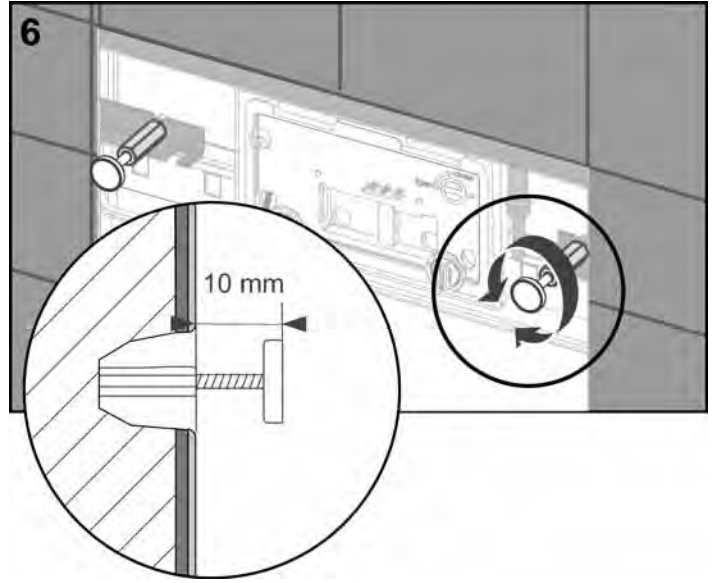

Screw in both securing magnets – 10 mm from wall surface.

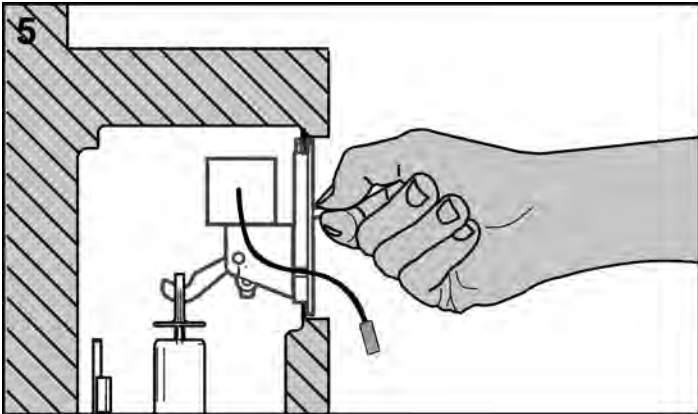
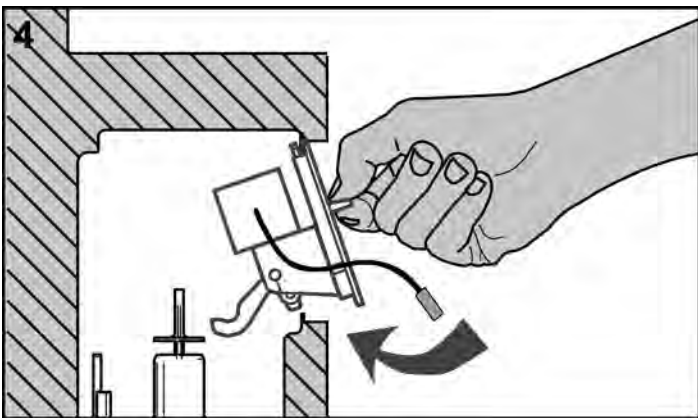

Insert the splash guard with electric actuation motor (supplied with the glass plate). No modification of the drain valve needed.

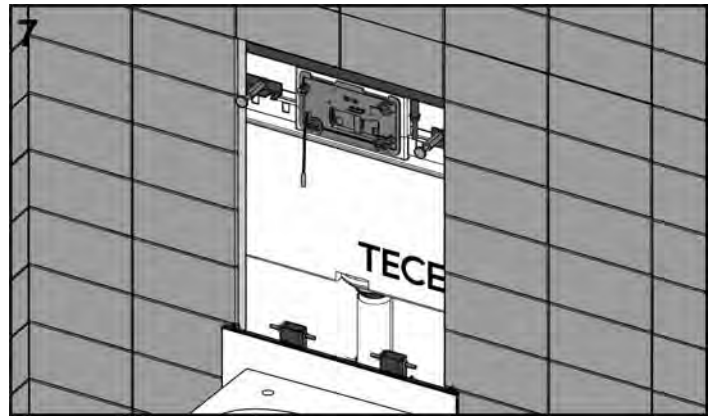

Insert the upper push plate into the brackets and fold it upwards.

TECElux – fine installation

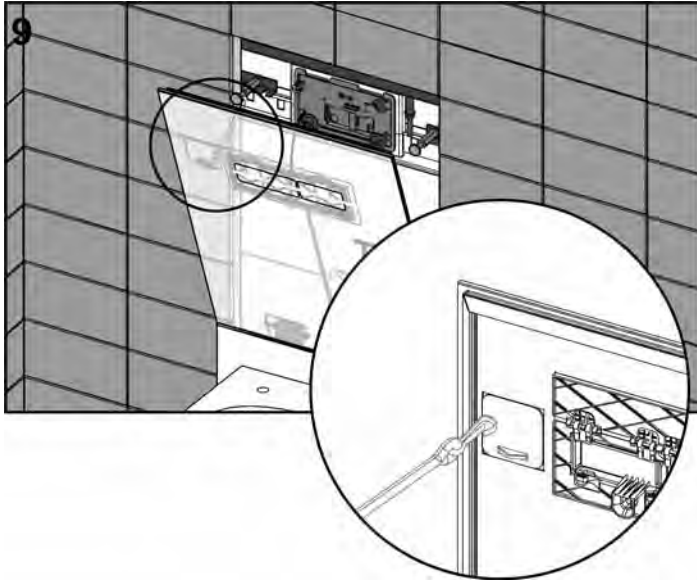

Secure the glass plate with security tape (engage the snap hooks into the eyes).

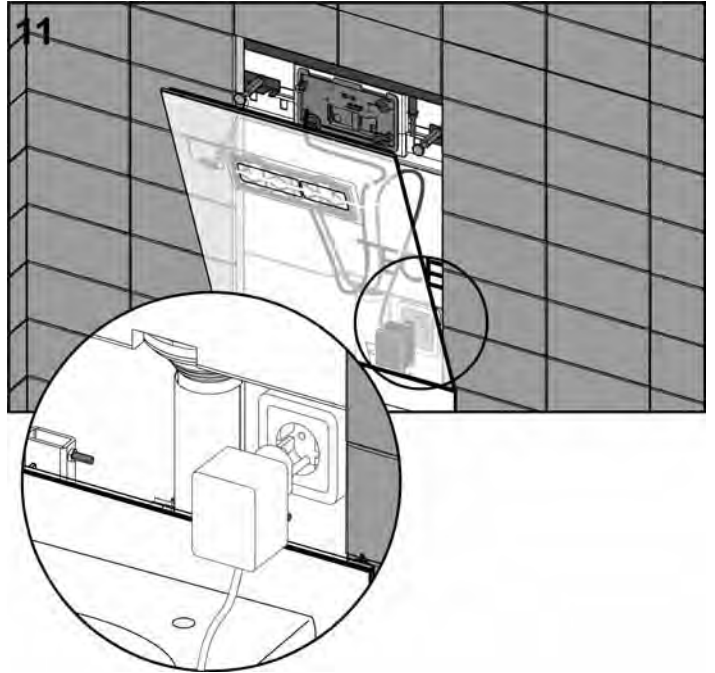

Plug the power supply unit into the mains socket.

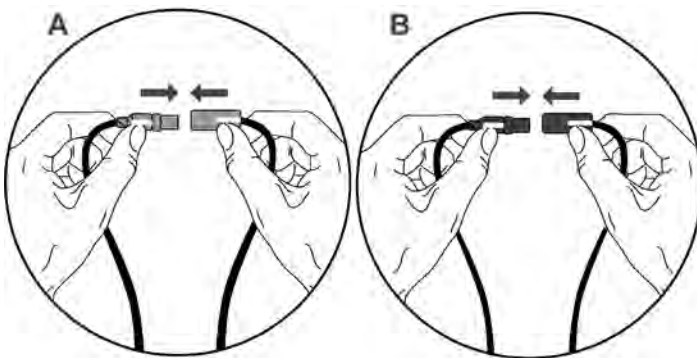
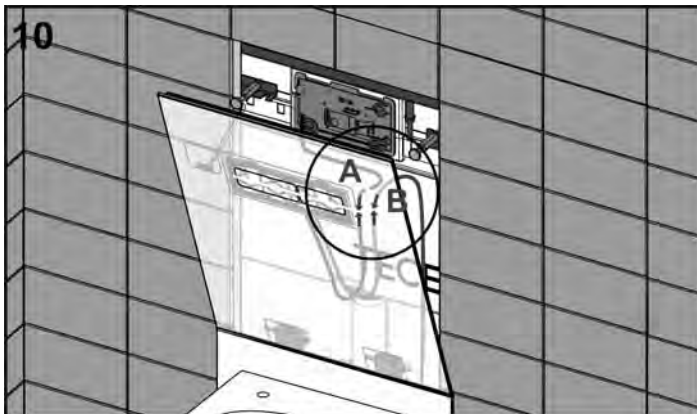

Connect the plug contacts to match:

- grey: actuation motor
- black: ceramic-Air odour extraction (if present)
- red: mains plug power supply unit

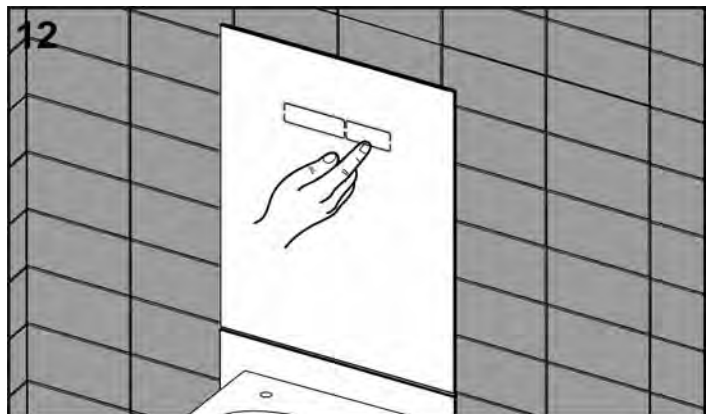

Check that the flush operates correctly, if necessary program the electronics.

Programming the TECeLux sen-Touch electronics

The sen-Touch electronics can be programmed within the first hour after connection to the power supply. If there is a further need to make a change, the power must be disconnected again. After a power cut, the last setting to be stored is kept, due to a built-in memory chip. A position on one of the two touch fields is assigned to each configurable function.

Large touch field:



Position	Function
1	Factory setting
2	Hygiene flush off
3	Hygiene flush 24 h
4	Hygiene flush 56 h
5	Hygiene flush 84 h
6	Hygiene flush 168 h
7	Hygiene flush 336 h
8	Hygiene flush 672 h
9	Illumination level 1 very bright
10	Illumination level 2 standard
11	Illumination level 3 dimmed
12	Illumination level 4 darker
13	Safety flush off
14	Safety flush on

 = Factory setting

Small touch field:



Position	Function
1	Recognition short
2	Recognition standard
3	Subsequent odour extraction 5 min.
4	Subsequent odour extraction 2 min.
5	Subsequent odour extraction 1 min.
6	Fan setting extra quiet
7	Fan setting standard
8	Fan setting power
9	Cleaning function on
10	Cleaning function off

 = Factory setting

Procedure

How to program the sen-Touch electronics:

- Touch the large or small touch field. After 10 seconds, programming mode starts with a series of quick signal tones.
- After the start phase, a series of identical individual signal tones can be heard. Count these – with the hand on the button – until you reach the required function.
- Then remove your hand; you hear a long confirmation signal tone.

Example: Set hygiene flush to 84 hours.

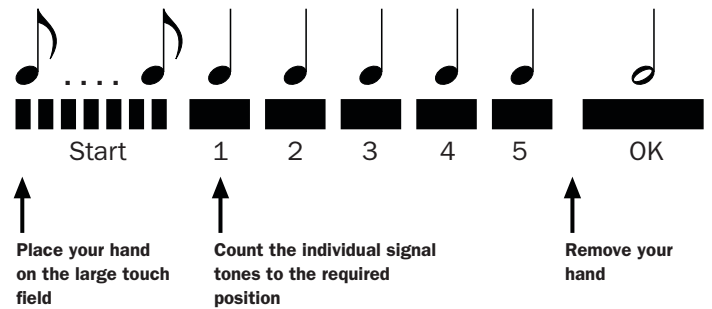

Cleaning function

When the cleaning function is activated, the touch field is deactivated for 30 seconds (requirement: function 9 on the small touch field is selected).

- Activate the cleaning function:
Simultaneously touch both touch fields for 7 seconds. After this period, the previously configured functions are automatically reset. The cleaning function can only be activated in standard operation – not during the programming phase.

Safety flush

If the safety flush is activated, a flush is actuated 2 minutes after a person was last detected in the recognition range and a flush has not been actuated since.

Manual actuation

A flush is also possible even if there is no power – e.g. after a power failure: To do this, pull the upper glass plate up from the wall and press the red actuating rod.





TECEdrainline
Technical Guidelines

Introduction	202
Requirements for building drainage	203
Sealing	203
Outlets	205
Loading capacity	206
Barrier-free bathroom design	206
TECEdrainline – the advantages	207
Hygiene	207
Easy height adjustment	208
Outlets	209
Covers	210
Installation examples	211
Range and technical data	214
Straight shower channel	214
Angled channel	214
Straight shower channel for natural stone	215
Outlets	216
Patterned grate	218
Glass cover	218
Tileable channel	219
Mounting feet	219
Fire protection set	220
Hair trap	220
Sound-proofing mat	220
Planning	221
Over-filling and falls	221
Sound insulation	222
Fire protection	223

Installation instructions	224
Shower channel installation instructions	224
Angled channel installation instructions	228
Shower channel for natural stone installation instructions	234
Super-flat outlet installation instructions	239
Vertical outlet installation instructions	240
Fire protection set installation instructions	241
Installation instructions for sound-proofing mat	244
Drainline feet installation instructions	245
Special channels	245
Assistance in measuring and ordering TECEdrainline shower channels	246
Assistance in measuring and ordering TECEdrainline shower channels for natural stone	248
Standards	250

TECEdrainline – introduction

Introduction

An innovation gets a hold on the bathroom: TECEdrainline is in a class of its own. 35 years of channel experience and just as many years of hygiene expertise from the industrial kitchen segment have made TECEdrainline a sophisticated product right from the start, tailored to the needs of today's contractors.

Shower channels open up new design options in bathroom architecture. Stainless steel shower channels (of stainless steel, material 1.4301 or 304) are now used not only in the conventional position between the dry and wet area, but are also installed directly against the wall.

TECEdrainline has been on the market since 2005 and in this time the applications have become more varied and still more creative.

In high-quality bathrooms the channels are also more often being incorporated into fine floors made of natural materials. The TECEdrainline natural stone set is particularly suitable for this application because of its stable edge area and the firmly connected sealing flange. In contrast to stainless steel covers, natural stone can be attached directly to the channel with adhesive and then installed in a thick-bed process. A support plate for the covering is also supplied. The natural stone layer cuts the stone to fit the support plate and glues it on. On a finished floor, this results in a continuous texture with narrow drain slots, without the stainless steel channel being noticeable.

Another option is the use of an angled channel or a tileable channel "plate", which can be clad with the particular flooring.



Requirements for building drainage

Sealing

Sealing the substrate before tiles are laid prevents water from entering the substrate. Sealing is especially important in the wall and floor areas which are directly exposed to spray water, i.e. in the shower or over the edge of the bath. A waterproof finish here ensures additional protection against moisture which can penetrate through the joints.

Seal according to the German Central Building Industry Federation (ZDB) data sheet:

According to the German Building Regulations, structures must be set out in such a way "that dangers or unacceptable burdens do not arise through water, moisture, [...] and other chemical, physical or biological influences".

Those components in structural works which are stressed through moisture, such as in bathrooms, showers, on terraces, balconies, commercially-used kitchens etc. must therefore be protected against moisture penetration.

Rooms or components which are liable to moisture exposure are as a rule provided with cladding or covering of tiles or flags. These claddings or ceramic coverings are moisture-proof and water-repellent, however, particularly because every type of joint in surfaces directly exposed to moisture is considered water-permeable, as a rule they require an additional seal.

The ZDB data sheet describes bonded damp-proofing with tiles and flags in indoor and outdoor areas, with regard to defined moisture loads and substrates.

The described thin-bed seals (bonded damp-proofing) have proved to be very effective in practical use. The data sheet represents an important basis for a professional planning and application system as a general rule. Furthermore, the special installation notes in the TECE installation manual must be followed.

For implementations according to these instructions, coverings and cladding with tiles and flags in thin-bed form a protective layer. For floor constructions with insulating layers, this sealing is applied immediately onto the load distribution layer (screed). The coating can be laid in thin-bed onto it, so that thicker protective layers are not required.

The advantages of thin-bed sealing are:

- The substrate cannot become soaked with waters which are hygienically or chemically suspect.
- Economically priced alternative to sealing according to DIN 18195.

TECEdrainline – requirements for building drainage

Moisture stress classes according to ZDB

Stress class	Stress	Field of application	Sealing material
A	high stress through non-pressurised water in indoor areas	directly and indirectly stressed surfaces in spaces in which service water and cleaning water is dealt with very often or for a long time, such as: in connection with swimming pools and shower installations (public or private)	- polymer dispersion, only for walls - plastic/mortar combination - reaction resins
B	high stress caused by constantly pressurised water from inside in indoor and outdoor areas	surfaces of containers stressed by pressurised water, such as public and private swimming pools in indoor and outdoor areas	- plastic/mortar combination - reaction resins
C	high stress caused by non-pressurised water with additional chemical influence in indoor areas	directly and indirectly stressed surfaces in spaces in which service water and cleaning water is dealt with very often or for a long time, where there are also limited chemical stresses to the sealing, such as in commercial kitchens and laundries	- reaction resins

Moisture stress classes in Building Authority supervised areas (high stress)

Stress class	Stress	Field of application	Sealing material
A0	moderate stress through non-pressurised water in indoor areas	directly and indirectly stressed surfaces in spaces in which service water and cleaning water is not very frequently dealt with, such as: in private bathrooms, bathrooms in hotels, floor areas with drains in these fields of application	- polymer dispersion - plastic/mortar combination - reaction resins With moisture-insensitive substrates in moderately stressed areas, sealing on wall areas is not absolutely essential, depending on the application in question. The connection to other stressed areas must be created with a sealing tape.
B0	moderate stress through non-pressurised water in an outdoor area	directly and indirectly stressed surfaces in an outdoor area with non-pressurised water load, such as: on balconies and terraces (not above used spaces)	- plastic/mortar combination - reaction resins

Moisture stress classes in an area not supervised by the Building Authority (moderate stress)

Application in in Building Authority supervised areas

For bonded waterproofing (system of sealing material and thin-bed mortar), a General Construction Certificate (GCC) from a recognised testing laboratory centre is compulsory. The GCC contains the following obligatory specifications:

- the field of application of the system
- minimum dry layer thickness of the sealing material
- product designation of the permitted thin-bed mortar and adhesive to be used

Furthermore, the sealant material must be labelled with the mark of conformity (Ü-symbol).

For stress class A, evidence of a European Technical Approval certificate (ETA) according to ETAg 022, part 1 and the specifications of part 2 of the list of technical building regulations (test certificate for stress class A) can alternatively be provided instead of a GCC. For moisture stress classes B and C, a European Technical Approval

certificate (ETA) without guidelines, which covers the relevant application areas can alternatively be presented. The specifications within the ETA are then obligatory.

Sealing systems which are placed on the market on the basis of an ETA must carry the CE marking. The thin-bed mortar and adhesive specified in the GCC or ETA must be certificated according to DIN EN 12004 and carry the CE marking.

Application in areas not supervised by the Building Authority

A GCC will not generally be issued for these areas. In stress classes A0 and B0, products with a GCC should likewise be used in accordance with the test principles for obtaining a GCC for bonded sealants.

For moisture stress class A, evidence of a European Technical Approval certificate (ETA) according to ETAg 022, part 1 and the specifications of part 2 of the list of technical building regulations (test certificate for stress class A) can alternatively be provided instead of a GCC.

Sealing systems which are placed on the market on the basis of an ETA must carry the CE marking. The thin-bed mortar and adhesive specified in the GCC or ETA in an unsupervised area must also be certificated according to DIN EN 12004 and carry the CE marking.

Sealing materials

Polymer dispersions are possible sealing materials for classes A and A0, plastic/mortar combinations can be used in classes A, A0, B and B0. Reaction resins are suitable for all classes, but in principle in the regulated area they are over-engineered. No technical approval is required for the unregulated area. However, the data sheet requires a quality certificate which was generated according to the same test principles as those which are compulsory in the Building Authority area.

Which set of rules govern what?

	Building Rules List	ZDB data sheet
Sealing materials and adhesives	X	X
Minimum thickness of layer	X	X
Substrates		X
Sealing of joints		X
Sealing of penetrations and fitted components		X

Floor surfaces

As substrates, only moisture-resistant materials are permitted, such as concrete according to DIN 1045, cement screed according to DIN 18560 (heated and unheated), unheated cast asphalt concrete according to DIN 18560 as well as, in the indoor area, composite elements made of expanded or extruded polystyrene with mortar coating and fabric reinforcement. The substrates must be sufficiently dry. The residual dampness of cement screeds must not exceed 2.0 CM%.

Wall surfaces

Suitable substrates are concrete according to DIN 1045, suitable cement or lime/cement plaster according to DIN EN 998-1 or DIN V 18550, fully pointed built masonry, aerated concrete elements, cavity wall panels made of lightweight concrete and hard-foam support plates with mortar coating.

Outlets

The essential structural requirements for floor outlets, such as drainage capacities, are described in DIN EN 1253. The table shows the minimum discharge values for floor and roof outlets (not for siphonic drainage). The minimum discharge value of an outlet with odour trap without lateral connections when accepting the waste water from a shower head may be taken as 0.4 l/s.

The discharge values for outlets with one or more inlets are to be taken from DIN EN 1253-1 paragraph 8.11.2.

Nominal value of outlet connectors		Floor outlets	
DN / OD	DN / ID	Discharge value	Water level a
32	30	0.4 l/s	20 mm
40	40	0.6 l/s	20 mm
50	50	0.8 l/s	20 mm
75	70	0.8 l/s	20 mm
110	100	1.4 l/s	20 mm
125	125	2.8 l/s	20 mm
160	150	4.0 l/s	20 mm

Outflow capacity (inflow via the grating) – minimum discharge values for outlets

Loading capacity

Outlets, top sections and gratings must be designed so that they withstand the loads which can be expected (e.g. also vehicular traffic). These classifications for installation inside buildings are described in DIN EN 1253-1.

Load class	Max. permitted load	Application scope/location
H 1.5	< 150 kg	For unused flat roofs, for example such as roofs with bitumen grit, poured gravel roof and the like.
K 3	< 300 kg	For surfaces without vehicular traffic, for example such as bathrooms in dwellings, hotels, retirement homes, schools, swimming baths, public washing and showering facilities, balconies, recessed balconies, terraces and green roofs.
L 15	< 1.5 t	For surfaces exposed to light vehicular traffic, not including fork lift trucks, in commercially used rooms.
M 125	< 12.5 t	For surfaces exposed to vehicular traffic, for example such as multi-storey car parks, factories and workshops.

Load capacity according to DIN EN 1253-1

The responsibility for selection of the suitable class lies with the planner. If there is any doubt, the higher load class must always be chosen.

Barrier-free bathroom design

Demographic change is increasing the demand for barrier-free dwellings. A disability, an accident or increasing age – there are many reasons why people are limited in their mobility or are dependent on a wheelchair. For them it is important that public buildings and above all their own four walls are equipped so that they can move around inside them without any problems. The technical term for this is "barrier-free". It requires sufficiently wide doors, no sills, no steps, a ground-level shower. With TECEdrainline, a life without sills and steps in the shower area is possible. The floor-level shower channel makes entrance into the shower area easier.

When planning a barrier-free bathroom, the specifications of DIN 18040-2 must be met.

DIN 18040-2:

DIN 18040-2 distinguishes between two types of requirements made upon dwellings. On the one hand, barrier-free dwellings and on the other hand, dwellings which are barrier-free and can be used by the wheelchair user without any restrictions. The second category is identified by a large bold **R** symbol.

General remarks:

- In dwellings with several bathrooms, at least one bathroom must be capable of barrier-free use.
- Fittings should be designed as a single-lever fitting or a non-contact fitting. With non-contact fittings, a temperature limiter must be provided. The water discharge temperature must be limited here to 45°C.

Movement areas:

A movement area must be designed in front of each of the items of sanitary equipment such as WC bowls, wash basins, baths and in the shower zone. A minimum area of 1.20 m x 1.20 m is sufficient for this (**R**: 1.50 m x 1.50 m). In doing so, movement areas may overlay one another.

Shower zones:

Shower zones must be configured in such a way that they can be used barrier-free, e.g. also with a walking frame or wheelchair.

This is achieved by:

- The layout of the bathroom on the same level as the adjoining floor area and a maximum lowering of 2 cm; where applicable, transition elements occurring should preferably be formed as inclined surfaces.
- Slip-proof floor coverings in the shower zone (in accordance with GUV-I 8527 at least rating group B);
- (**R**) the facility to retrofit a folding shower seat, with a seat height from 46 cm to 48 cm;
- (**R**) the facility to retrofit fold-up safety support arms both sides of the folding shower seat, whose top edge lies 28 cm above the height of the seat.)

The surface of the shower zone can be included in the movement areas of the bathroom if

- the transition to the shower zone is designed level with the floor;
- the incline required for drainage is a maximum of 2 %.

TECEdrainline – the advantages

Hygiene

The channel body of the TECEdrainline is made of stainless steel, without any gaps, screws or edges which cannot be reached. Hair, soap residues and other contamination cannot therefore build up on the inside of the channel. It is thus easy to clean and is especially hygienic. The inside of the channel is simply cleaned with a cleaning cloth. The immersion pipe can be easily removed for cleaning purposes. The "self-cleaning" outlet can be rinsed out using the shower head. Because drainline is made of stainless steel – material 1.4301 (304) – no cleaner may be used which can attack this material.

In an emergency, if there is an obstruction of the drain pipe, access is provided for a small manual pipe cleaning coil. A mark on the inside of the outlet shows the position of the outlet socket for this.

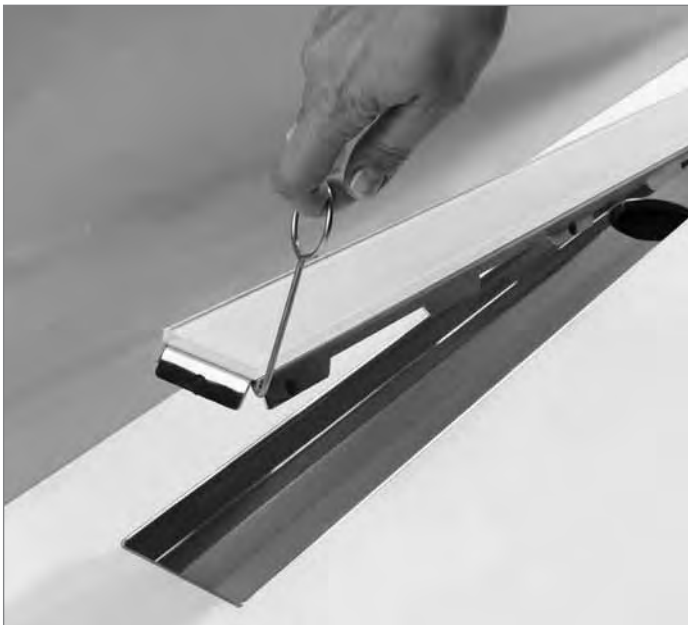

Remove the cover using the lifting tool



Remove the immersion pipe for cleaning purposes



Clean the outlet pipe using a small manual pipe cleaning coil



Clean the channel body - do not use any aggressive cleaning agents

TECEdrainline – the advantages

Easy height adjustment

The mounting feet simplify installation of the TECEdrainline. Using only one screw on each foot, drainline is easily and quickly matched to the required floor level. The clip mechanism is an additional advantage. The feet are simply clipped into the two brackets of the channel and the channel can be aligned! Within the scope of supply of the foot there is also a sound-absorbing element.

This is inserted between the foot and the fixing screw; and together with the drainbase sound-proofing mat it prevents an acoustic bridge between the floor and the mounting foot.

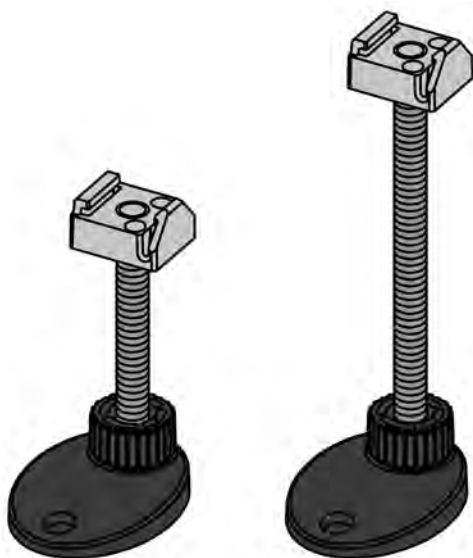

Mounting foot – normal and long format (according to the floor drain)

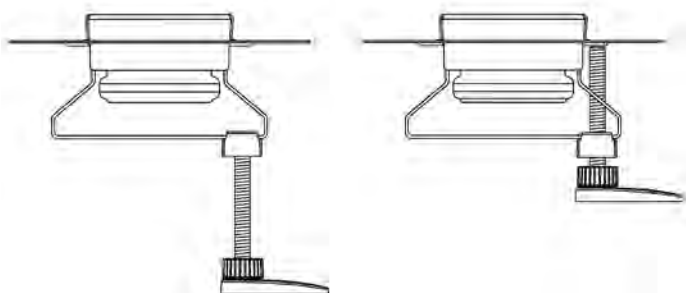

Height-adjustment facility of the mounting feet



Sound-absorbing element on the mounting foot

Outlets

Horizontal

In the TECE modular system there are several horizontal plastic outlets for various applications. The lowest assembly height among the outlets is 67 mm. This "super-flat" outlet has a drainage capacity of 0.5 l/s. For power showers, which need a high drainage capacity, TECE has an outlet with a particularly high drainage capacity of 1.2 l/s in the range. The minimum assembly height here is 148 mm. The "flat" outlet has a minimum assembly height of 95 mm and has a drainage capacity of 0.7 l/s, the assembly height of the "standard" outlet is a minimum of 120 mm, the drainage capacity 0.8 l/s.

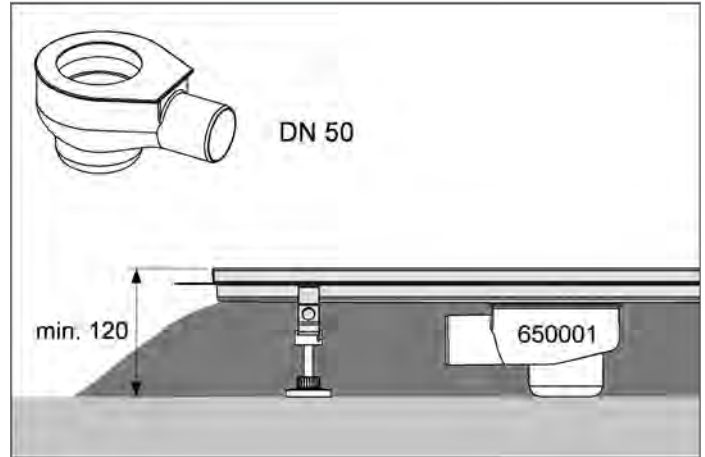

"Standard" outlet

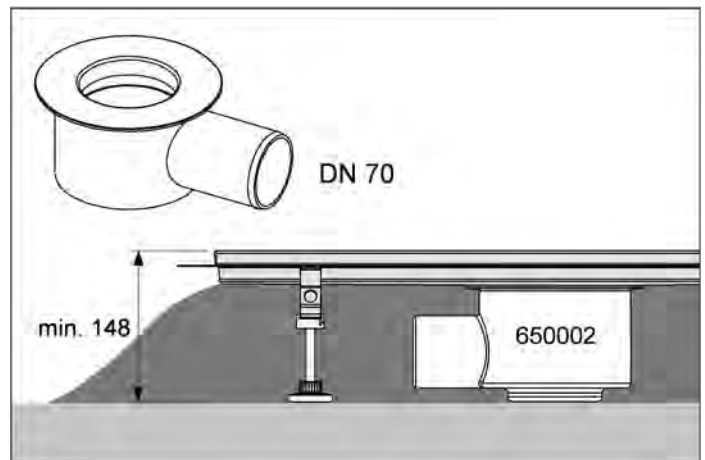

"Max" outlet

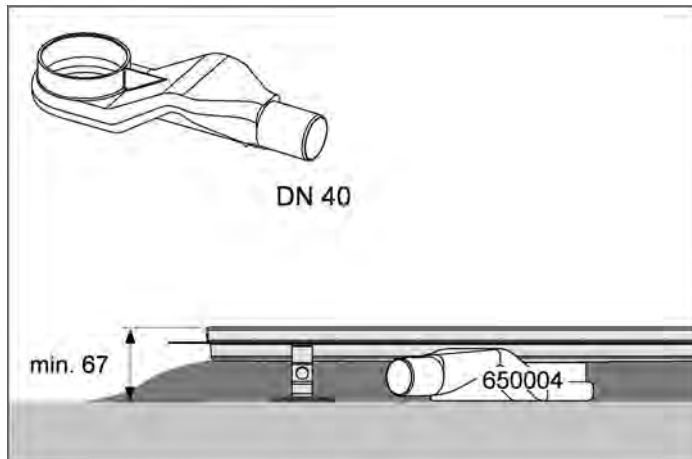

"Super-flat" outlet

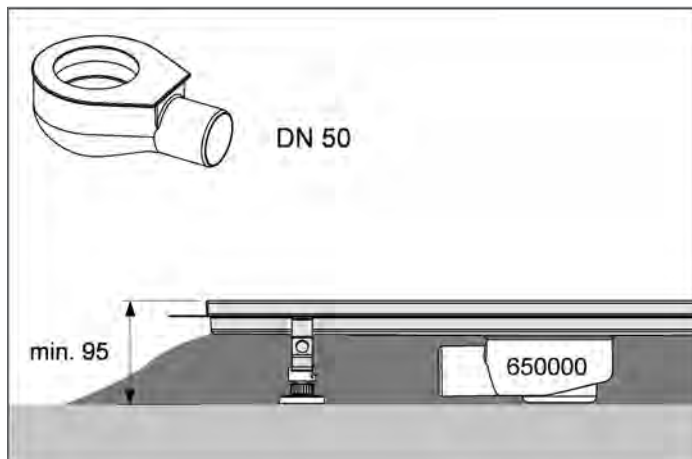

"Flat" outlet

Vertical

Besides the horizontal outlets, there is one vertical outlet which is built into the shell base with a 130 mm core bore. Here the minimum assembly height is only 65 mm. This outlet has a drainage capacity of 1.3 l/s.

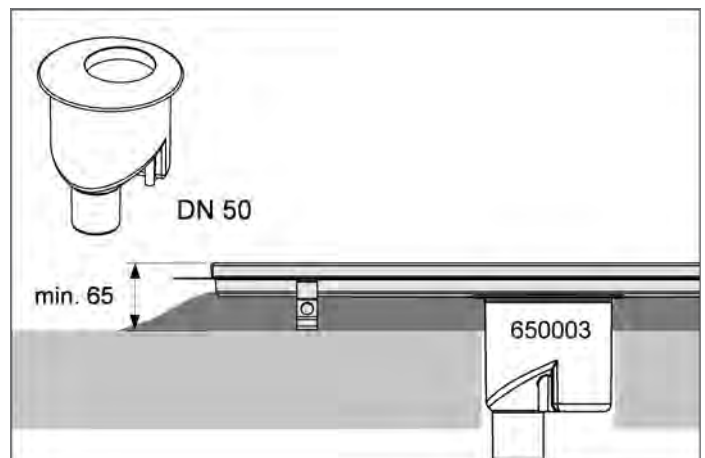

"Vertical" outlet

TECEdrainline – the advantages

Covers

There are eight patterned covers with different surfaces (stainless steel and glass) as well as a tileable channel to choose from.

The TECEdrainline patterned grates are made of stainless steel and are available with a polished or brushed finish. In addition, there are also visually appealing glass covers in a variety of colours. The glass covers are secured to stainless steel mountings.

All stainless steel covers are available to match the channel length in straight and angled versions and according to load class K3 are loadable up to 300 kg.

Thin-bed flange

The channel is delivered with a cut-to-size sealing layer for sealing on-site. The adhesive applied to the flange in the factory ensures a completely watertight joint with the sealing material.

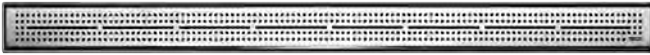

"Quadratum" patterned grate



"Steel II" patterned cover



Glass cover



"Plate" tileable channel

Installation examples

TECEdrainline shower channels open up new design options in bathroom architecture – and bathroom planners are taking advantage of this new freedom: For example, shower channels are mostly inserted directly against the wall or close to the wall, but drainline also finds application as the transition from the wet area into the dry area.

Installation "In the room"



Installation "In the room"

When installing the TECEdrainline "in the room", as well as the incline of 1 % in the wet area, a rise with a 5 mm height difference on the other side of the channel must be included (see "Installation instructions for shower channels with a horizontal outlet").

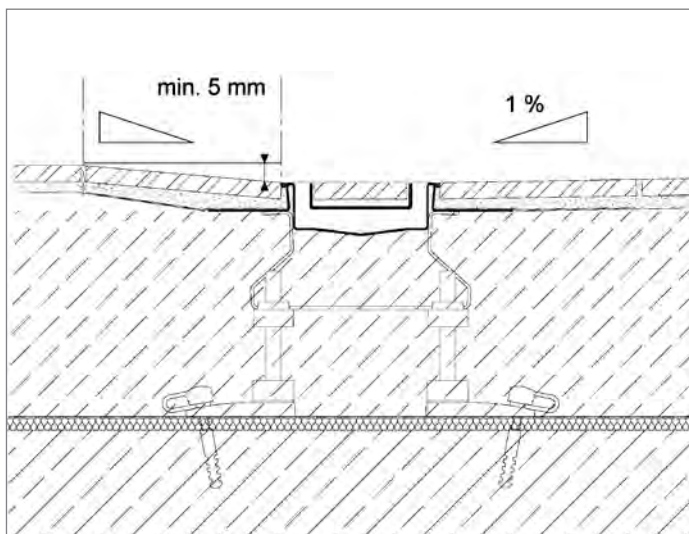

Installation "In the room", incline

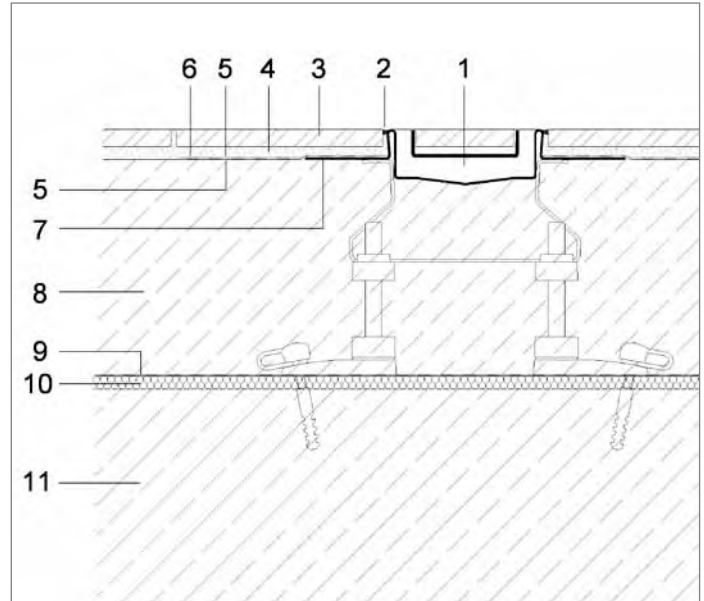

Installation "In the room", layer construction:

- | | |
|-------------------------|----------------------------------|
| 1. Shower channel/cover | 7. Channel flange |
| 2. Flexible grouting | 8. Screed |
| 3. Tile covering | 9. PE film |
| 4. Tile adhesive | 10. Drainbase sound-proofing mat |
| 5. Sealing coating | 11. Unfinished floor |
| 6. Sealing material | |



"Parallel" installation

When using two parallel installed shower channels, as well as the incline of 1 % from the centre of the wet area to the channel, a rise with a 5 mm height difference "behind" the channel must also be included.

TECEdrainline – example installation



Installation of angled channels "In the room"

Drainline angled channels can also be used as an alternative to the straight version. Achieving the required incline is somewhat more difficult than with the straight version. The water in the wet area must thus be able to flow away evenly in both arms. With large format tiles, a diagonal cut from the corner of the wall to the crest of the channel is thereby required – see illustration above. This is not required for small-format tiles (mosaic). The highest point in the wet area is thus located in the corner of the wall. Furthermore, a rise of 5 mm height in the dry area must be provided, to prevent water overflow.

Installation "Directly against the wall"



Installation "Directly against the wall"

The standard configuration of the channel has been optimised for installation directly against the wall: The flange on straight channels is pre-stamped on one of the long sides and on-site it can therefore be bent over at 90 ° using pliers.



Bending the channel flange

Bending must be done in stages over the whole length of the channel and the film and the adhesive on the flange must not be damaged in the process.

Bending has the advantage that the shower channel can now be installed particularly tight against the wall. Cutting of tiles between the wall and the edge of the shower channel is dispensed with. When the wall tiles are laid, care must be taken that they do not protrude into the visible area of the shower channel and thereby interfere with the insertion of a grate.

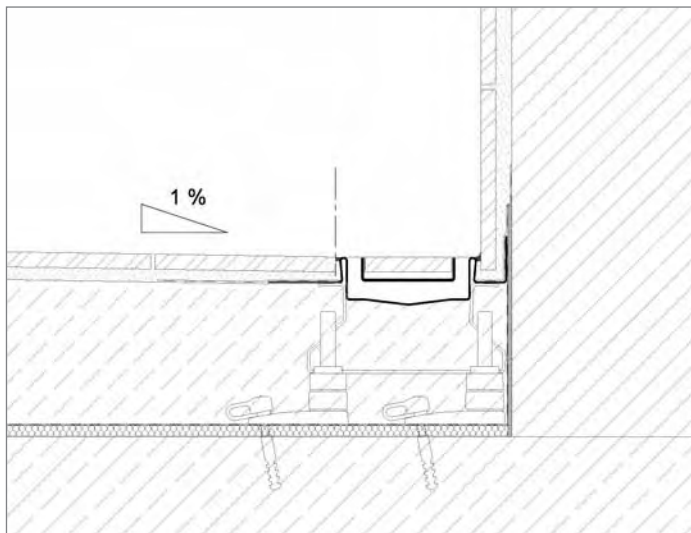

Installation "Directly against the wall", incline

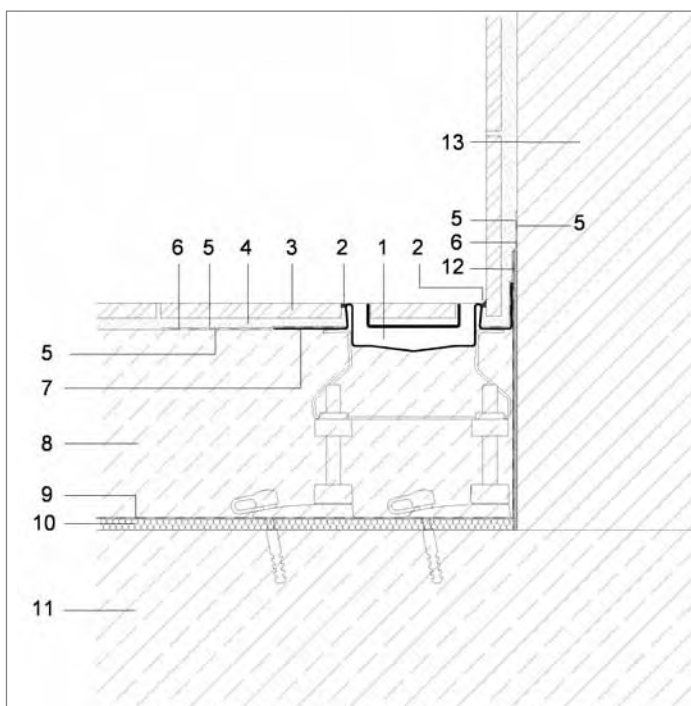

Installation "Directly against the wall", layer construction:

- | | |
|-------------------------|----------------------------------|
| 1. Shower channel/cover | 8. Screed |
| 2. Flexible grouting | 9. PE film |
| 3. Tile covering | 10. Drainbase sound-proofing mat |
| 4. Tile adhesive | 11. Unfinished floor |
| 5. Sealing coating | 12. Edge insulation strip |
| 6. Sealing material | 13. Brickwork / masonry |
| 7. Channel flange | |

Installation "Close to the wall"

In contrast to installation directly against the wall, when used close to the wall the flange does not need to be bent. Because of this, an intermediate space between the channel and the wall is formed, which can be laid for example with narrow sections of tile or mosaic tiles.



Installation "Close to the wall"

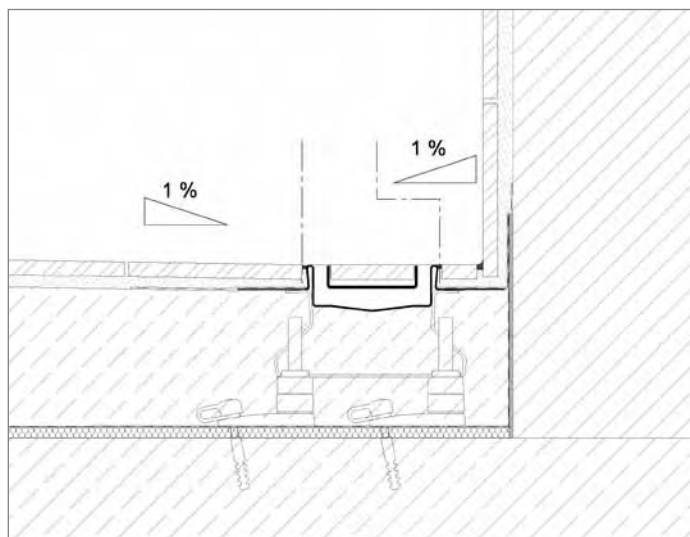

Installation "Close to the wall", incline

For further information on the installation of shower channels, please refer to the section "Installation instructions".

TECEdrainline – range and technical data

Range and technical data

Straight shower channel

TECEdrainline channel, straight with sealing material
(Altered Dimensions and delivery units)

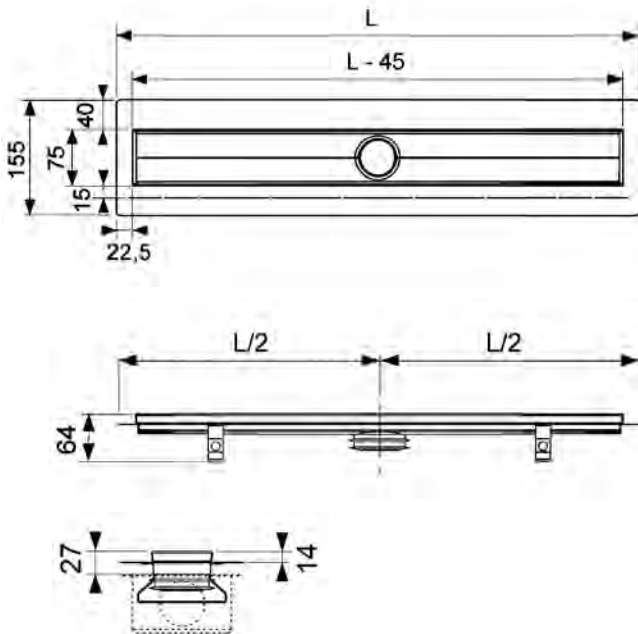
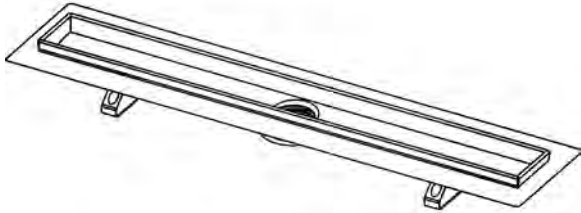

Straight channel body for TECEdrainline shower channel, for installation in screed, with insulating flange and sealing material for on-site sealing.

Consisting of:

- Stainless steel channel body
- Pre-formed insulating flange with watertight special adhesive surface on the top face for on-site bonding of the sealing material
- Watertight sealing with the tile surface, for on-site inclusion in the sealing coating of the thin-bed seal
- Two connecting clips for anchoring in the screed and for fitting optional mounting feet
- Central connecting piece for outlet
- With inner incline for improved water drainage
- Seals

Please order separately: patterned grate, tileable channel or glass cover, outlet, mounting feet (optional) and drainbase sound-proofing mat (optional)

Order number	Channel length L	Shell dimension including insulating flange L	Visible dimension after installation L - 45
600700	700 mm	700 mm	655 mm
600800	800 mm	800 mm	755 mm
600900	900 mm	900 mm	855 mm
601000	1000 mm	1000 mm	955 mm
601200	1200 mm	1200 mm	1155 mm
601500	1500 mm	1500 mm	1455 mm

Straight version range with dimensions

Angled channel

TECEdrainline angled channel with sealing material
(Altered Dimensions and delivery units)

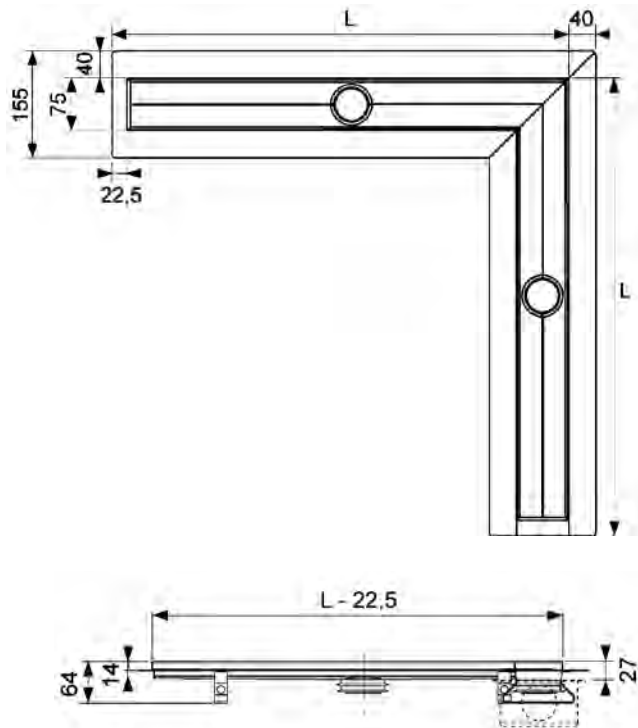
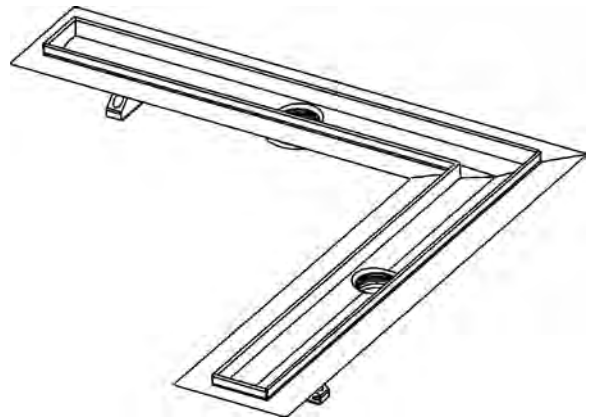

Channel body in 90° angled version, for TECEdrainline shower channel, for installation in screed, with insulating flange and sealing material for on-site sealing.

Consisting of:

- Stainless steel channel body welded in a single unit
- Pre-formed insulating flange with watertight special adhesive surface on the top face for on-site bonding of the sealing material
- Watertight sealing with the tile surface, for on-site inclusion in the sealing coating of the thin-bed seal
- Three connecting clips for anchoring in screed and for fitting optional mounting feet
- Two centrally placed connecting pieces for outlets
- With inner fall for improved water drainage
- Seals

Please order separately: patterned grate or tileable channel, outlets (2 x), mounting feet (2 sets, optional) and drainbase sound-proofing mat (optional)

Order number	Channel length L	Shell dimension including insulating flange L + 40 mm	Visible dimension after installation L - 22.5 mm
610900	900 x 900 mm	940 x 940 mm	875 x 875 mm
611000	1000 x 1000 mm	1040 x 1040 mm	975 x 975 mm
611200	1200 x 1200 mm	1240 x 1240 mm	1175 x 1175 mm
611500	1500 x 1500 mm	1540 x 1540 mm	1475 x 1475 mm

Angled channels range with dimensions

Straight shower channel for natural stone

TECEdrainline channel for natural stone, straight, with stainless steel support

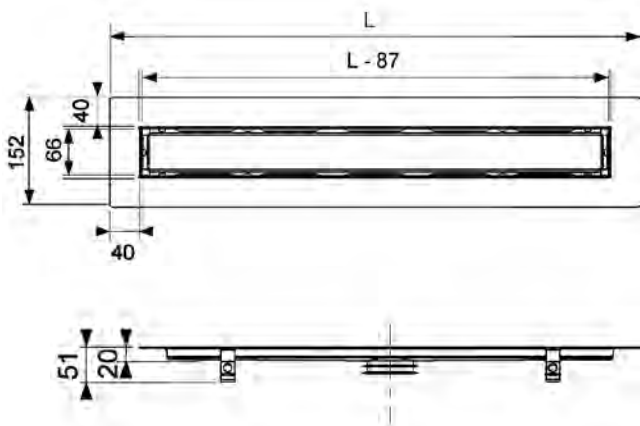

Straight channel body and support for TECEdrainline shower channel for installation in screed and for on-site application of large-format tiles/natural stone flags, with insulating flange for on-site sealing or for direct bonding with natural stone flags

Consisting of:

- Stainless steel channel body
- Pre-formed 40 mm wide insulating flange for on-site sealing
- Connecting clips for anchoring in screed and fitting of optional mounting feet
- With central connecting piece for outlet
- With inner fall for improved water drainage
- Stainless steel support for installation in the channel body
- Seals

Please order separately: Outlet, mounting feet (optional) and drainbase sound-proofing mat (optional)

Order number	Channel length	Shell dimension including insulating flange L	Support length* L - 89
650700	700 mm	735 mm	646 mm
650800	800 mm	835 mm	746 mm
650900	900 mm	935 mm	846 mm
651000	1000 mm	1035 mm	946 mm
651200	1200 mm	1235 mm	1146 mm
651500	1500 mm	1535 mm	1446 mm

* Covering cutout length = L - 89

Shower channel range for natural stone with dimensions

TECEDrainline – range and technical data

Outlets

"Super-flat" outlet

TECEDrainline super-flat outlet, DN 40 side discharge, 0.5 l/s

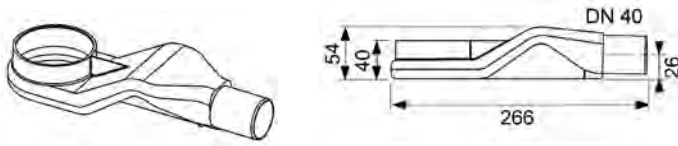

Super-flat outlet for TECEDrainline shower channel for rotatable installation at the channel body and side connection to DN 40 waste water pipe, with removable trap immersion pipe

- Assembly height from lower edge of outlet to upper edge of shower channel = 67 mm
- Drainage capacity of shower channel with "basic" patterned grate = 0.5 l/s (without immersion pipe 0.6 l/s)
- Reduced sealing water height = 30 mm (without immersion pipe 20 mm)

Order number 6 500 04

"Flat" outlet

TECEDrainline flat outlet, DN 50 side discharge, 0.7 l/s

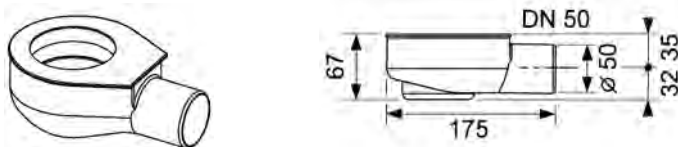

Flat outlet for TECEDrainline shower channel for rotatable installation at the channel body and side connection to DN 50 waste water pipe, with removable trap immersion pipe

- Assembly height from lower edge of outlet to upper edge of shower channel = 95 mm
- Drainage capacity of shower channel with "basic" patterned grate = 0.73 l/s
- Reduced sealing water height = 25 mm

Order number 6 500 00

"Standard" outlet

Standard TECEDrainline outlet, DN 50 side discharge, 0.8 l/s

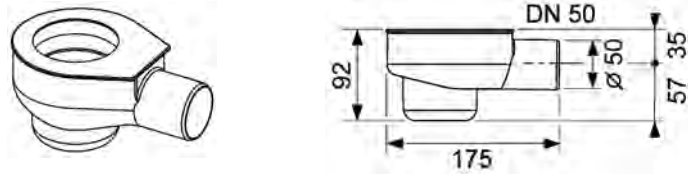

Outlet for TECEDrainline shower channel for rotatable installation at the channel body and side connection to DN 50 waste water pipe, with removable trap immersion pipe

- Assembly height from lower edge of outlet to upper edge of shower channel = 120 mm
- Drainage capacity of shower channel with "basic" patterned grate = 0.8 l/s
- Sealing water height = 50 mm; in accordance with DIN EN 1253.

Order number 6 500 01

"Max" outlet

TECEDrainline max, DN 70 side discharge, 1.2 l/s

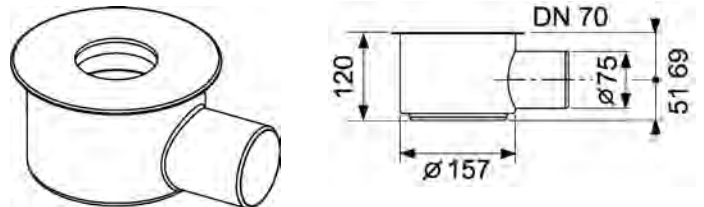

Large outlet for TECEDrainline shower channel for rotatable installation at the channel body and side connection to DN 70 waste water pipe, with removable trap immersion pipe

- Assembly height from lower edge of outlet to upper edge of shower channel = 148 mm
- Drainage capacity of shower channel with "basic" patterned grate = 1.53 l/s
- Sealing water height = 60 mm; in accordance with DIN EN 1253 > 50 mm

Order number 6 500 02

"Vertical" outlet

TECEDrainline vertical outlet, DN 50, 1.3 l/s.

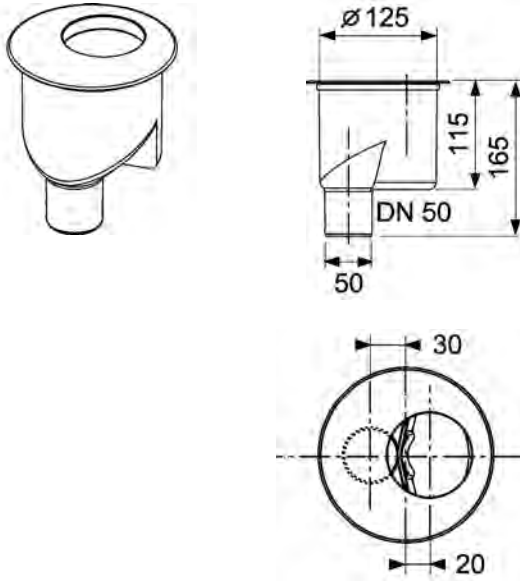

Vertical outlet for the TECEDrainline shower channel for rotatable installation at the channel body and side connection to DN 50 waste water pipe, with removable trap immersion pipe

- Minimum assembly height from upper edge of channel to lower edge of stirrup = 65 mm
 - Drainage capacity of shower channel with "basic" patterned grate = 1.4 l/s
 - Sealing water height = 50 mm in accordance with DIN EN 1253.
 - Core bore required = 130 mm
- Order number 6 500 03

Drainage capacities

The TECEDrainline outlet range includes five outlets for different requirements and structural features. The models match all the shower channels in the TECEDrainline programme.

Outflow capacities of TECEDrainline floor outlets in combination with various covers in accordance with DIN EN 1253-2:

Patterned grate	Super-flat outlet 650004 (PP)	Flat outlet 650000 (PP)	Standard outlet 650001 (PP)	Max outlet 650002 (PP)	Vertical outlet 650003 (PP)
"basic" 600710/1	0.5 l/s*	0.7 l/s	0.8 l/s	1.5 l/s	1.4 l/s
"lines" 600720/1	0.5 l/s*	0.7 l/s	0.8 l/s	1.5 l/s	1.4 l/s
"drops" 600730/1	0.5 l/s*	0.7 l/s	0.8 l/s	1.5 l/s	1.4 l/s
"royal" 600740/1	0.5 l/s*	0.7 l/s	0.8 l/s	1.5 l/s	1.4 l/s
"quadratum" 600750/1	0.5 l/s*	0.7 l/s	0.8 l/s	1.5 l/s	1.4 l/s
"organic" 600760/1	0.5 l/s*	0.7 l/s	0.8 l/s	1.5 l/s	1.4 l/s
"steel II" 600782/3	0.5 l/s*	0.7 l/s	0.8 l/s	1.5 l/s	1.4 l/s
"plate", tiled 600770	0.5 l/s*	0.7 l/s	0.8 l/s	1.2 l/s	1.3 l/s

* Data for outlet with immersion pipe, without immersion pipe 0.6 l/s

Outflow capacity of TECEDrainline floor outlets in accordance with DIN EN 1253-2

TECEdrainline – range and technical data

Patterned grate

TECEdrainline patterned grate in polished/brushed stainless steel

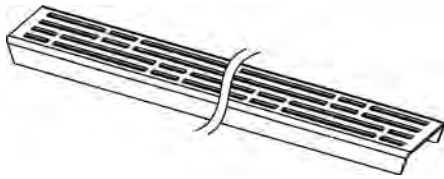

"basic" version patterned grate

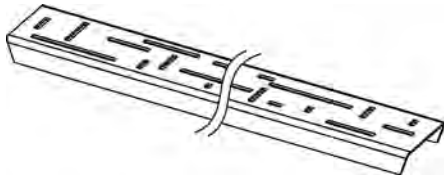

"lines" version patterned grate

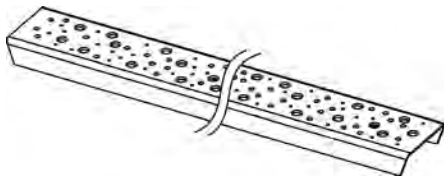

"drops" version patterned grate

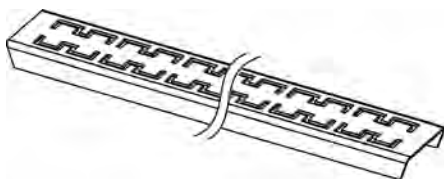

"royal" version patterned grate

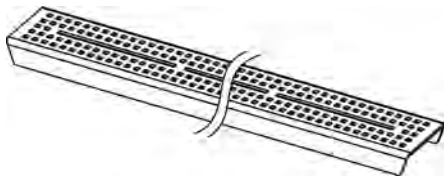

"quadratum" version patterned grate

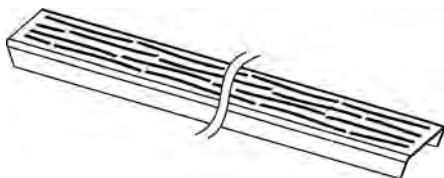

"organic" version patterned grate

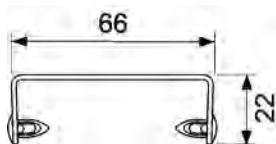
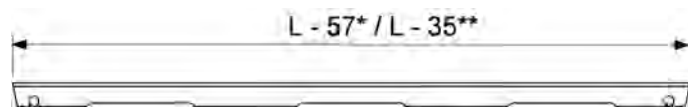

Patterned grate dimensions (straight version/angled version)

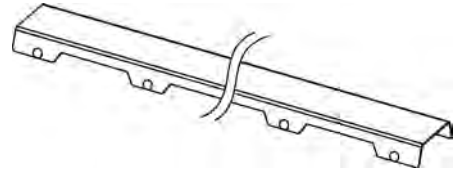

"steel II" version patterned grate

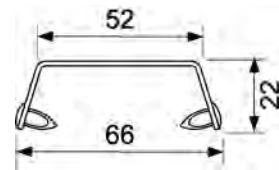
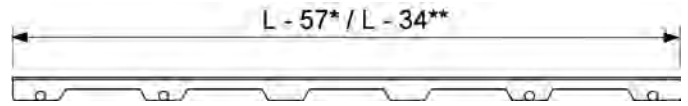

"steel" patterned grate dimensions (straight version/angled version)

Patterned grate for TECEdrainline shower channel made of stainless steel (angled version "steel II" only in polished stainless steel) for insertion in the channel body, load capacity to load class K3 – test load 300 kg. Various patterns, two-part for angled channel

For straight channel: Visible length = channel length
L - 45 mm

For angled channel: Visible length = channel length
L - 22.5 mm

Glass cover

TECEdrainline glass cover stainless steel with glass surface

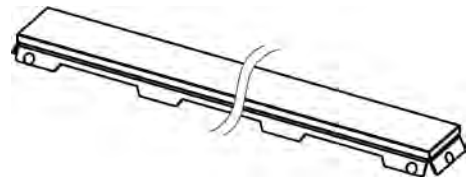

Glass cover

Patterned grate for TECEdrainline shower channel made of stainless steel with a glass surface for inserting in the straight channel body, load capacity to load class K3 – test load 300 kg, three different colours (white, green, black), visible length = channel length L - 45 mm

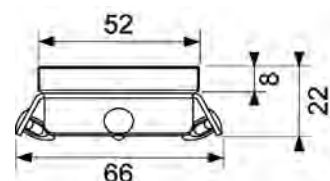
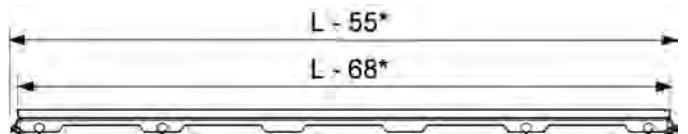

Glass cover dimensions (straight version only)

Tileable channel

TECEDrainline "plate" tileable channel

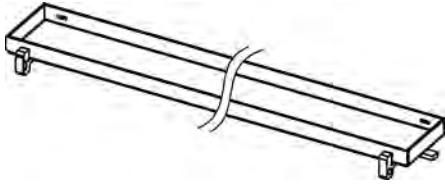

"plate" tileable channel

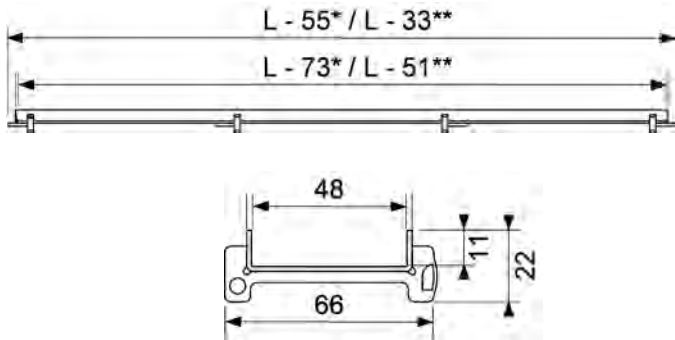

Tileable channel dimensions

Tileable channel for TECEDrainline shower channel, for fitting into the channel body, made of stainless steel with polished visible edges. Maximum test load 300 kg based on load class K3. Can be tiled on-site using a flexible adhesive, e.g. silicone or epoxy resin adhesive.

Caution: Check the adhesive to ensure tile tolerance !

Design version = "plate", two part for angled channels

For straight channel: Visible length = channel length

L - 45 mm

For angled channel: Visible length = channel length

L - 22.5 mm



Installation example: "plate" tileable channel

Mounting feet

Mounting feet, for fitting to the TECEDrainline shower channel body, for easy adjustment of the channel body height during shell assembly.

Adjustable range from base of feet to top of finished floor = 92–139 mm

Consisting of:

- Four mounting feet incl. sound-absorbing elements
- Fastening material

Order number 6 600 03

Mounting feet, for fitting to the TECEDrainline shower channel body, for easy adjustment of the channel body height during shell assembly.

Adjustable range from base of feet to top of finished floor = 137-184 mm

(for "flat" and "standard" outlets)

Consisting of:

- Four mounting feet incl. sound-absorbing elements
- Mounting materials

Order number 6 600 04 (for "Max" outlet)

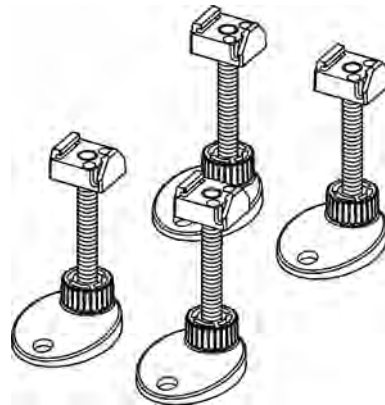

Mounting feet

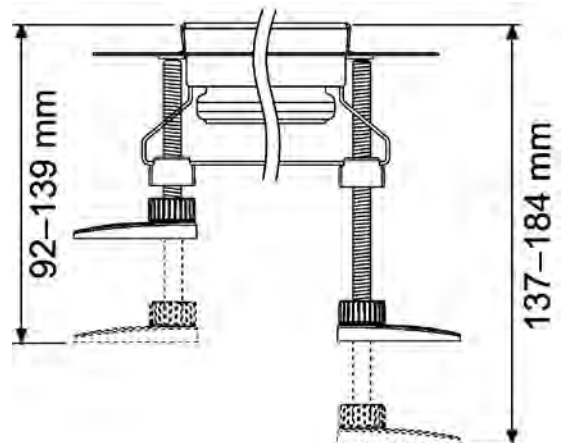

Mounting feet adjustable range: 6 600 03 (left) and 6 600 04 (right)

TECEdrainline – range and technical data

Fire protection set

TECEdrainline fire protection set FireStop EI 120 DN 50

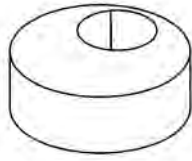

Fire protection set

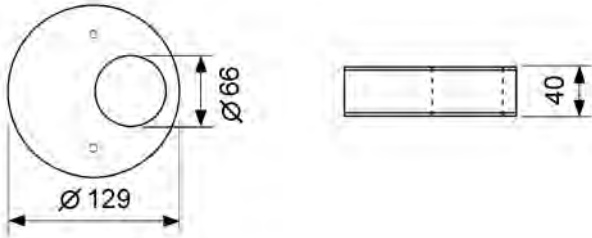

Fire protection set dimensions

Fire protection set for installation directly on the TECEdrainline DN 50 vertical outlet for highly fire-resistant separation of floor ducts in solid floors for up to 120 minutes. Classification according to DIN EN 13501 for fire protection class EI 120.

- Set consists of: Fire protection sleeve, 2 crosshead screws, identification plate
- Core drill hole required: \varnothing 130 mm (\varnothing min = 129 mm, \varnothing max = 133 mm)
- Field of application: Solid floors from 150 mm to 325 mm floor thickness
- Connecting pipe: PP-HT pipe according to DIN EN 1451 (minimum length 100 mm)
- No mortar mix nor filling of the intermediate space required
- Compatible with all TECEdrainline channels and covers

Hair trap

TECEdrainline hair trap

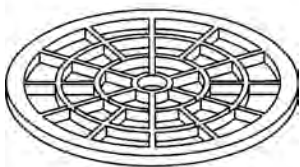

Hair trap

For placing on the immersion pipe of the TECEdrainline channel body, made of stainless steel

Take out the hair trap regularly and remove the hair.

Sound-proofing mat

Drainbase sound-proofing mat for TECEdrainline and TECEdrainboard

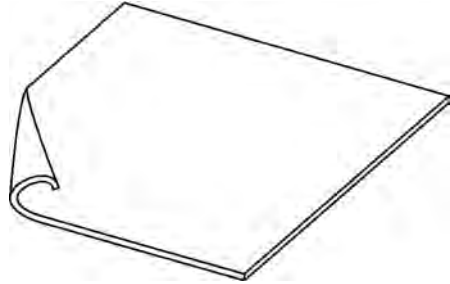

"Drainbase" sound-proofing mat

Sound-proofing mat for installation under floating screed in the area of floor-level showers or throughout the bathroom. For the reduction of plumbing noises and improvement in footfall sound absorption, for refurbishment and new build.

Plumbing noise level with normal shower setting: 22 dB(A) with TECEdrainline. Made of high-strength rubber granules from recycled material and bonded with PUR elastomer. Meets the sound insulation requirements according to DIN 4109 issue 2001-01 as well as the increased sound insulation requirements according to VDI 4100 issue 2007-08 (certificate from Fraunhofer Institute for Building Physics provided on request)

- Supplied as: 1.25 m x 1.25 m x 6 mm and 8.0 m x 1.25 m x 6 mm (roll, about 50 kg)
- Fire classification: B2 (DIN 4102)
- Thermal resistance: 0.05 (m²·K)/W
- Compression at 15 t/m²: 0.6 mm

Planning

Over-filling and incline

For a shower channel to function smoothly, its position is decisive. Once the position in relation to the room and wall aspects have been defined, the requirements of the incline can follow. Installation of the shower channel along the wall hardly involves any problems. When the appropriate incline is present, the water flows away from the middle of the room.

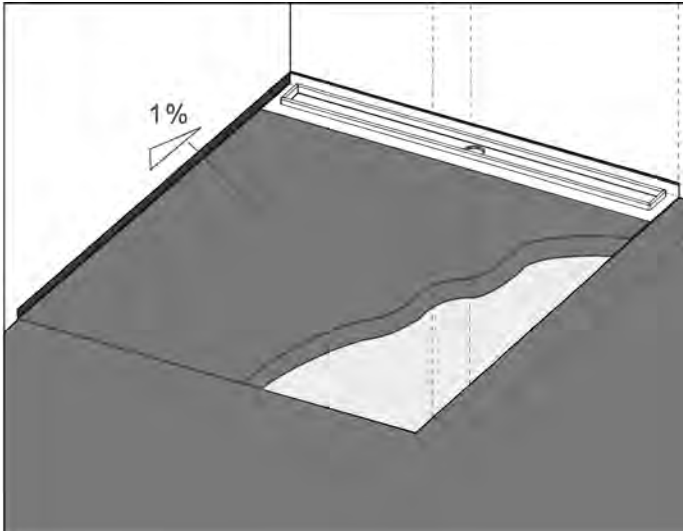

Installation at the wall – schematic diagram

It becomes somewhat more problematic if the shower channel is laid towards the room. Usually when planning floor drains, DIN EN 1253 is taken as a basis. It specifies the drainage capacity at an accumulation height of 20 millimetres above the grate. When there is a shower channel installed on the room side, the water would however flow into the adjoining bathroom area. For this reason, care must be taken that the drainage values without over-filling (max. 5 mm) are approved.

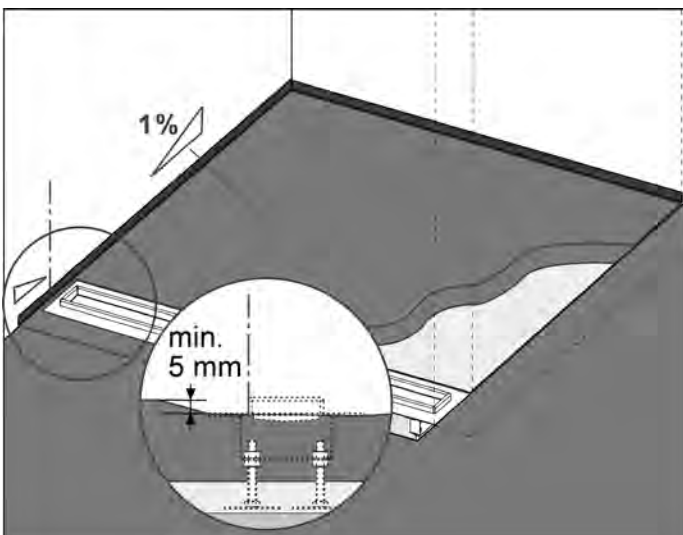

Installation in the room – schematic diagram

To prevent flooding, TECE recommends a rise behind drainline (please take the detailed suggestions for solutions from the TECE installation instructions).

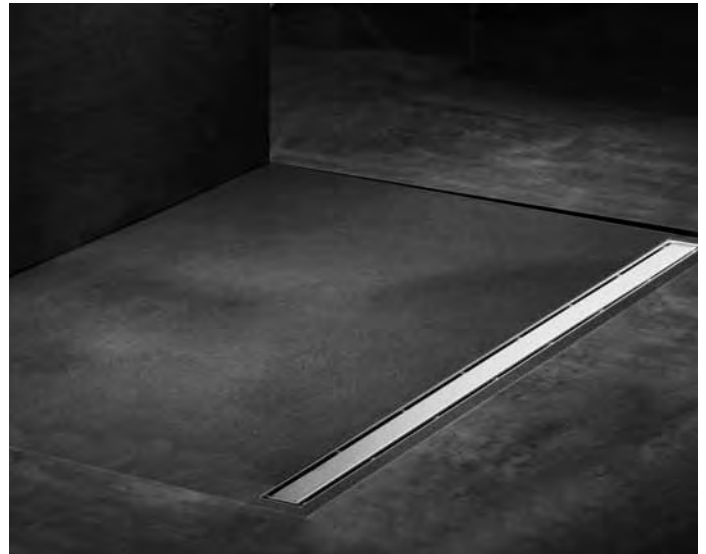

Installation in the room taking into account the incline

Sound insulation

The TECE range offers the pressure-proof "Drainbase" sound-proofing mat for sound insulation. The mat which is just 6 mm thick is laid in the whole shower area, between the shell floor and the screed. The shower channel, mounting feet, outlet and waste water pipe thus stand directly on a sound-proofing mat covered with a PE film and are completely uncoupled from the structure.

This sound-proofing mat meets the requirements of DIN 4109 and also the more stringent requirements of VDI 4100 (sound absorption level III). It can be used for both the TECEdrainline and the TECEdrainboard. According to DIN 4109, the requirements for the sound pressure level in living and sleeping areas caused by water installations are ≤ 30 dB(A), the more stringent requirements according to VDI 4100 (sound absorption level III) are actually only ≤ 25 dB(A). The eco-friendly sound-proofing mat made of recycled rubber in combination with the TECEdrainline achieves a sound pressure level of 22 dB(A). This value is confirmed by an official test report from the Fraunhofer Institute for Building Physics. In contrast to the usual sound-proofing material made of expanded polystyrene, the TECE sound-proofing mat does not yield when subjected to load. Even with a pressure of 15 t/m², the deformation by compression is only 0.6 mm. For this reason, the silicone joint between the floor and the wall covering is prevented from separating.



Drainbase sound-proofing mat

Drainbase technical data:

Material	recycled rubber granules bonded with PU elastomer
Colour	black/coloured
Surface	smooth with granular structure
Width	1.250 mm
Length	1.250 mm
Thickness	6 mm
Tensile strength	approx. 0.4 N/mm ²
Elongation at break	approx 50%
Temperature stability:	-30 °C to +80 °C
Fire behaviour	B2
Load	approx. 15 t/m ² at 10 % compression

Installation example with sound-proofing mat

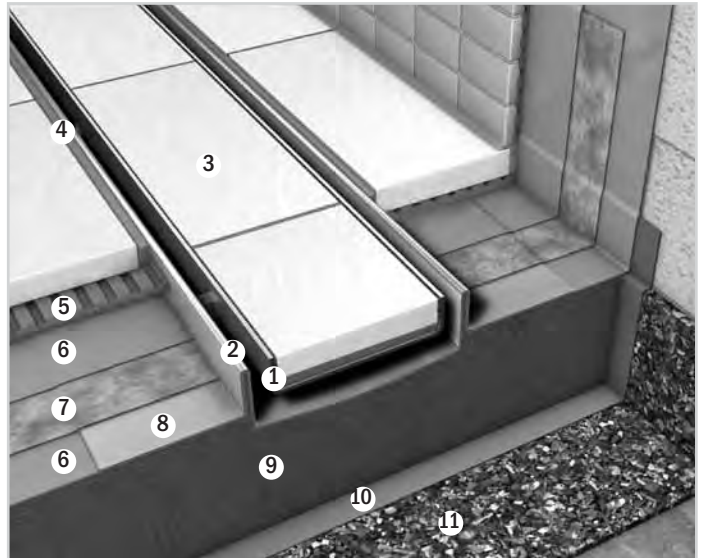

- | | |
|-----------------------------|----------------------------------|
| 1. "plate" tileable channel | 7. Sealing material |
| 2. Channel body | 8. Channel flange |
| 3. Tile cover | 9. Screed |
| 4. Flexible grouting | 10. PE film |
| 5. Tile adhesive | 11. Drainbase sound-proofing mat |
| 6. Insulating coating | |

Fire protection

FireStop fire protection set for the vertical drain.

With FireStop fire protection, TECE offers a safe and innovative fire protection solution up to fire resistance class EI 120 according to DIN EN 13501-2:2007 and A1:2009.

On the inside of the fire protection sleeve there are special gypsum plates enriched with additives. On the outside and in the socket area there are adhesive strips made of intumescent material based on expandable graphite – see illustration:

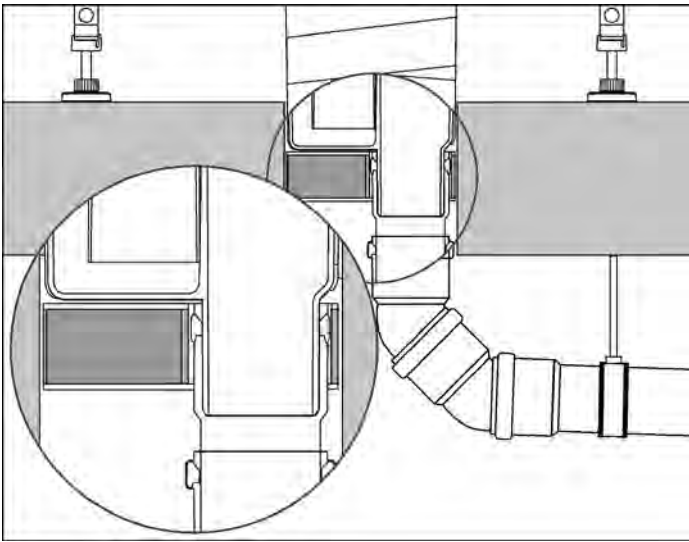

As temperatures rise during a fire, this material foams up to many times its original form.

This causes the remaining annular gap towards the core bore on the outside of the fire protection sleeve to close – see illustration:

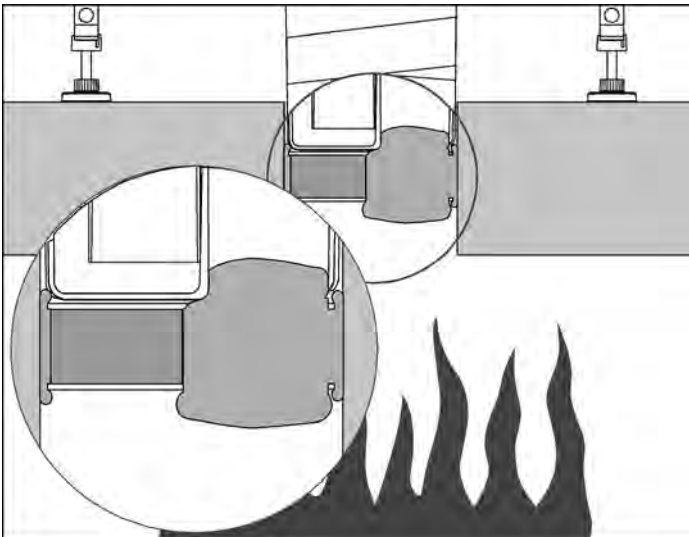

In the socket area, the outlet socket including the pushed-on HT pipe sleeve become crushed.

The sealing water found in the outlet (trap) ensures that no smoke and gases escape into the room to be protected. Together this creates a tested, highly fire-resistant pipe closure system (or firewall).

The usual mortar mix/filling of the remainder of the hole is not required with the TECE fire protection set.

TECEdrainline – installation instructions

Installation instructions

Installation of the various TECE shower channels is basically shown with a horizontal outlet. For the specific features when using a vertical or super-flat outlet, please refer to the corresponding instructions.

Shower channel installation instructions

When installing the TECEdrainline, the job steps sometimes differ, depending on the installation situation. A distinction is made between installation in the middle of the room (A) and a position close to the wall (B).

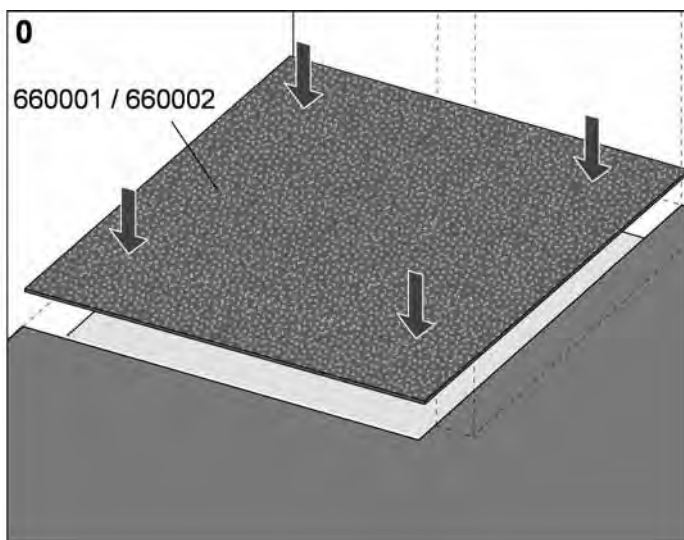

Optional: Cut the drainline sound-proofing mat and put it in position so that it covers the whole surface of the shower area.

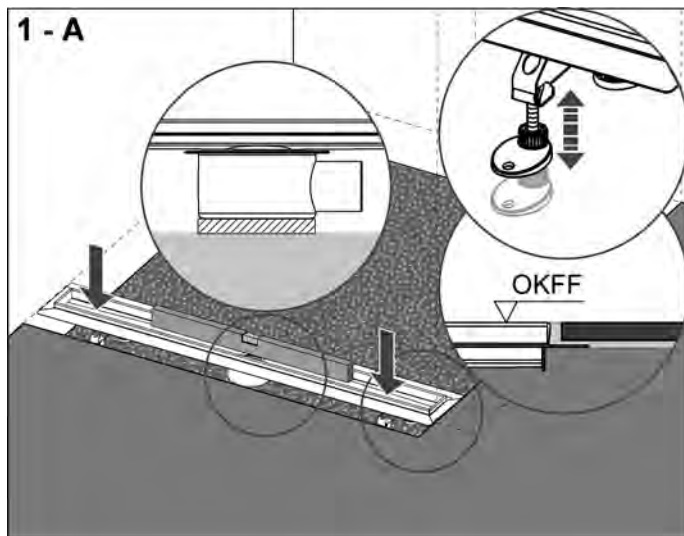

(A = position in the middle of the room)
Use the adjustable mounting feet to align the shower channel horizontally, if necessary underfill the drain bowl.

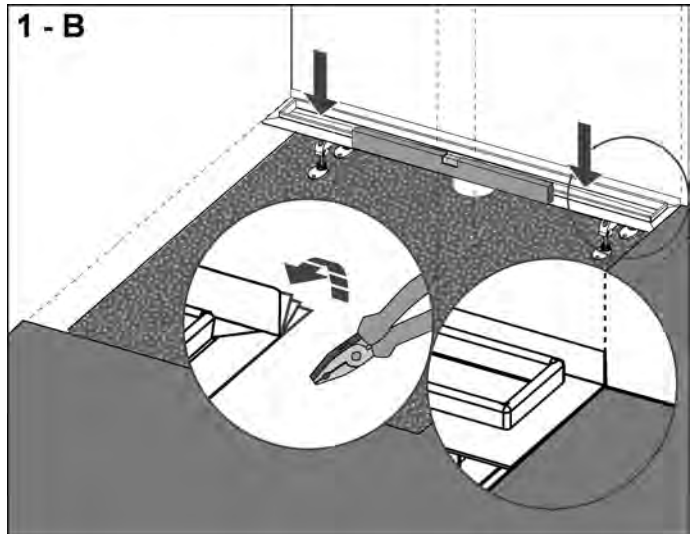

(B = position close to the wall)
Use a suitable pair of pliers to bend over the flange working in stages, do not damage the adhesive and film.
Use the adjustable mounting feet to align the channel horizontally, if necessary underfill the drain bowl.

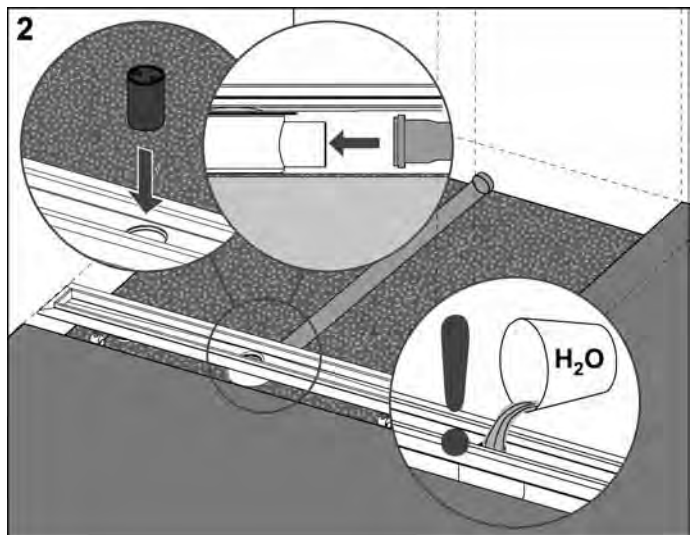

Secure the waste water pipe to the outlet socket. Test for leaks and insert the immersion pipe into the channel.

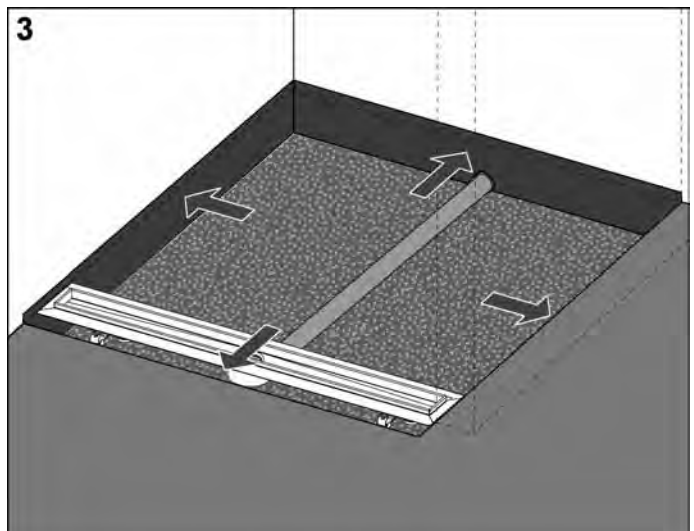

Add edge insulation strips on all sides.

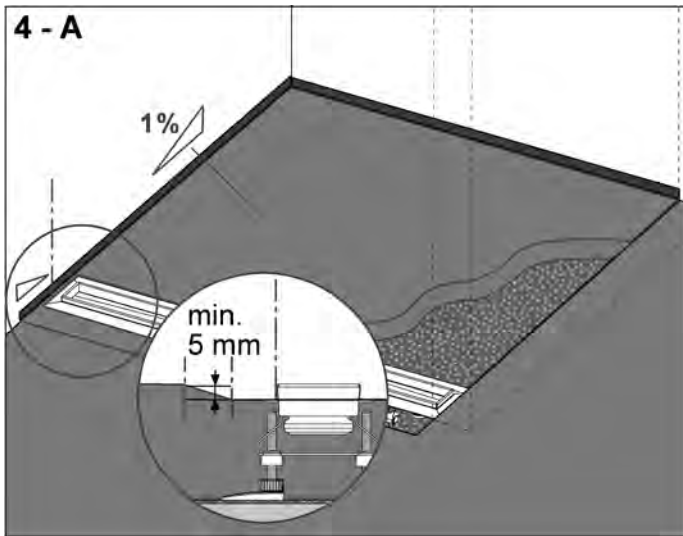

(A = position in the middle of the room)
 Include an incline of one percent. Include a rise of at least 5 mm when installing in the middle of the room.

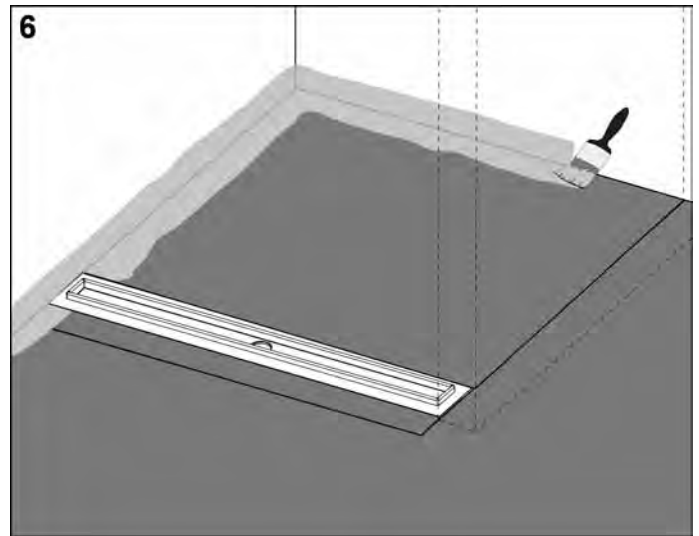

Apply a sealing coating to the transitions between the wall and the screed.

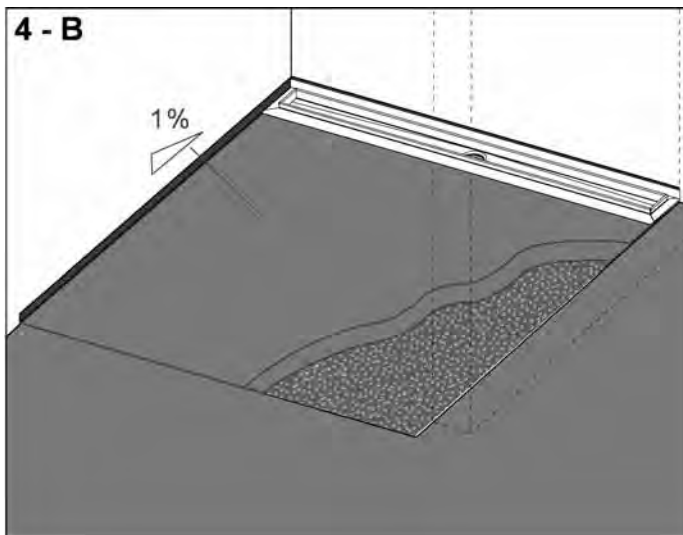

(B = position close to the wall)
 Include an incline of one percent.

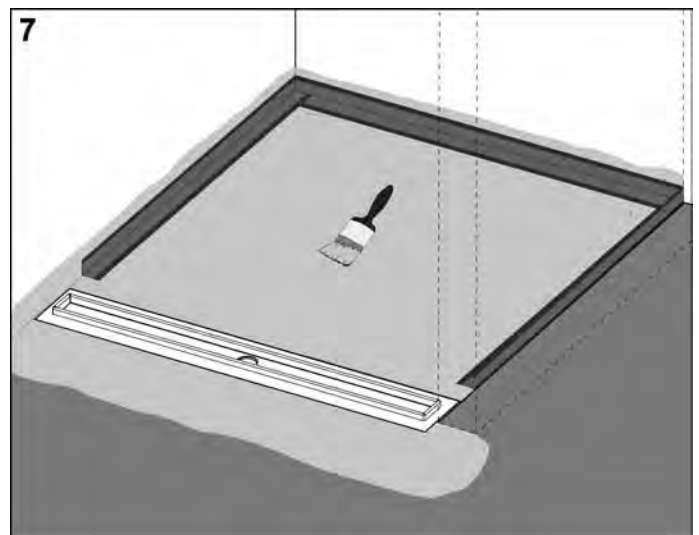

Apply the first sealing coating in the wet area and around the shower channel.

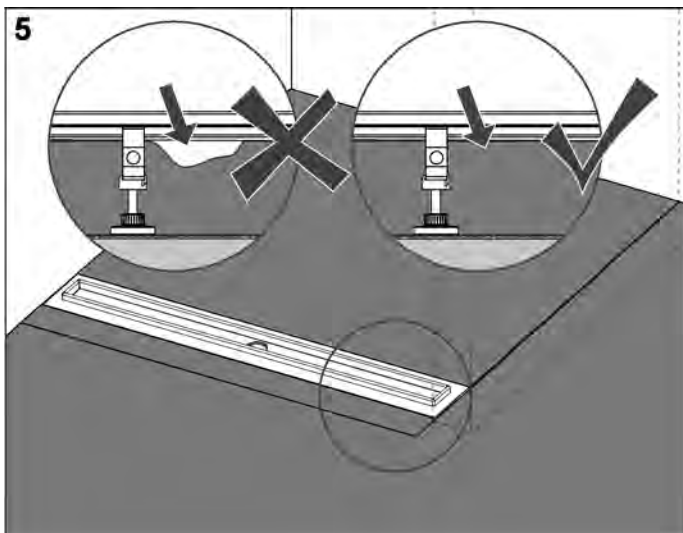

There must be no cavities at all between the screed and the channel or outlet!

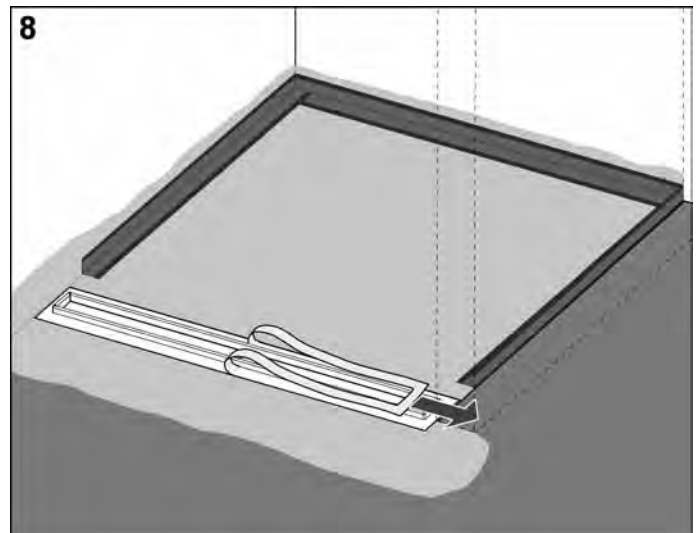

Pull off the blue protective film from the adhesive layer on the flange.

TECEdrainline – installation instructions

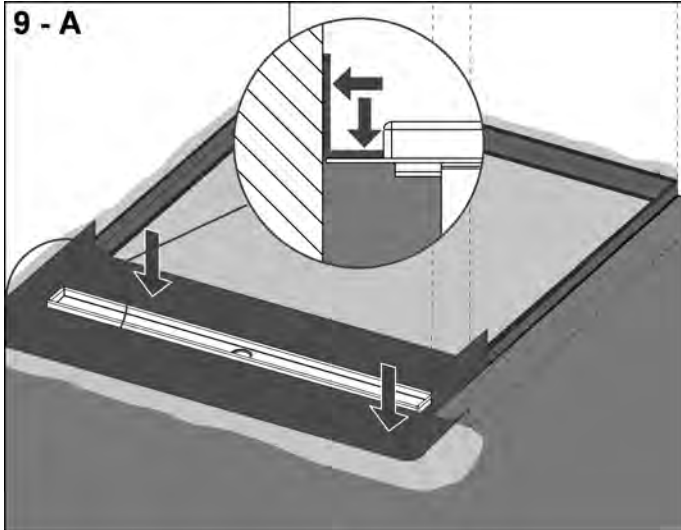

(A = position in the middle of the room)
Stick on the sealing material included in the delivery in a clean and bubble-free manner, to the floor area and the wall area.

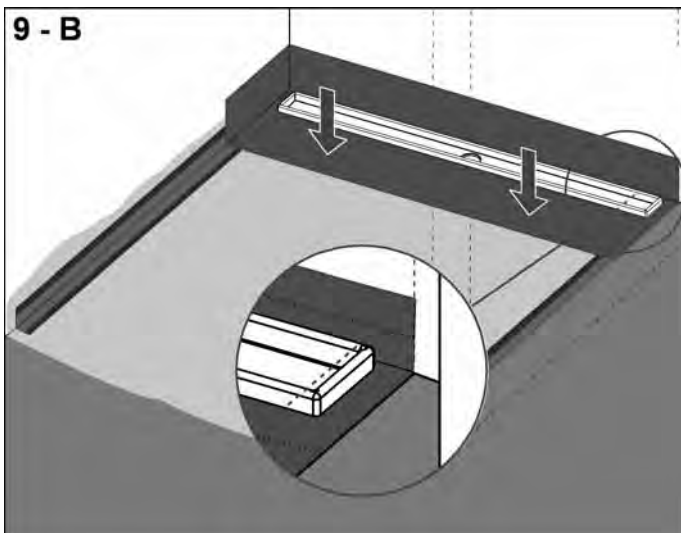

(B = position close to the wall)
Stick on the sealing material included in the delivery in a clean and bubble-free way, to the floor area and the wall area.

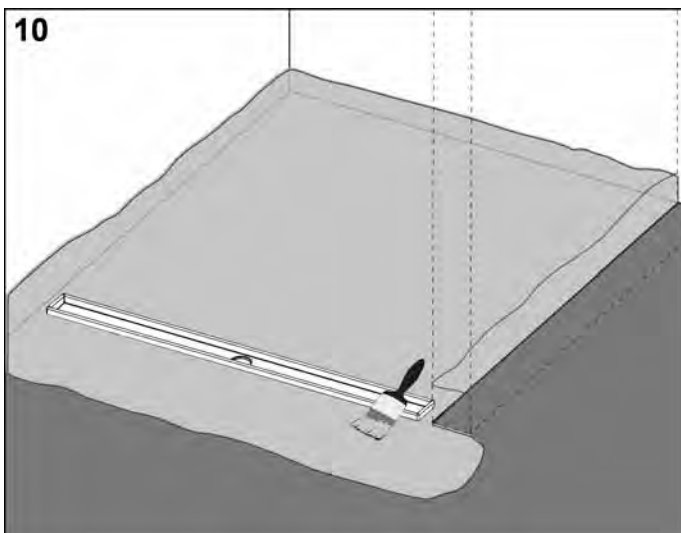

Apply a sealing coating over the complete wet area.

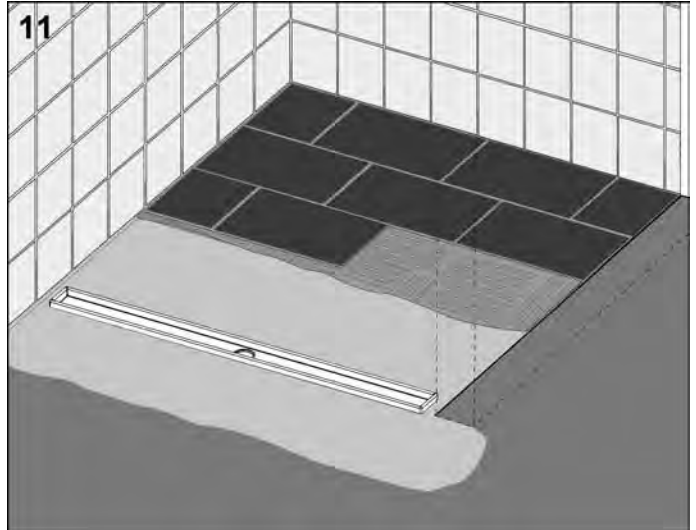

Apply tile adhesive and lay the tiles or natural stone.
Maintain the necessary incline of 1 %.

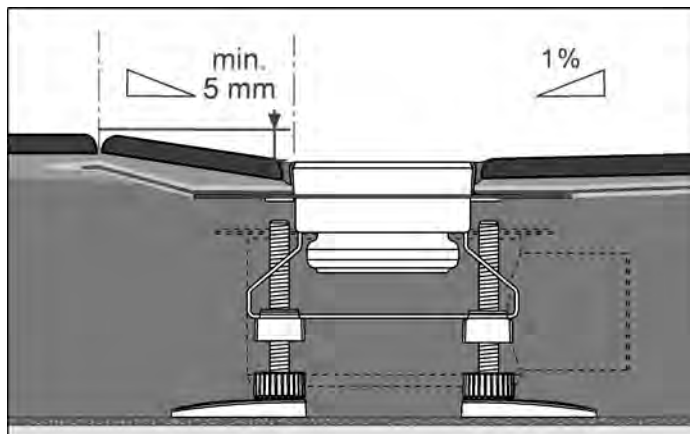
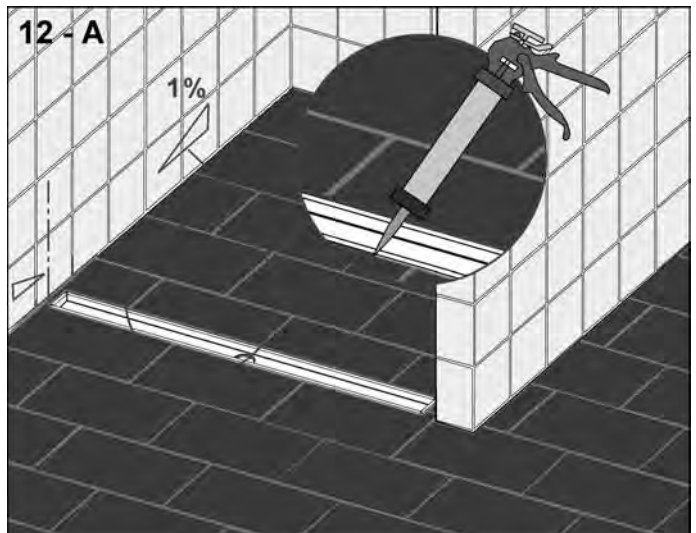

(A = position in the middle of the room)
Seal the joint between the stainless steel channel and the tiles or natural stone with permanently flexible material.
Check the incline and rises.

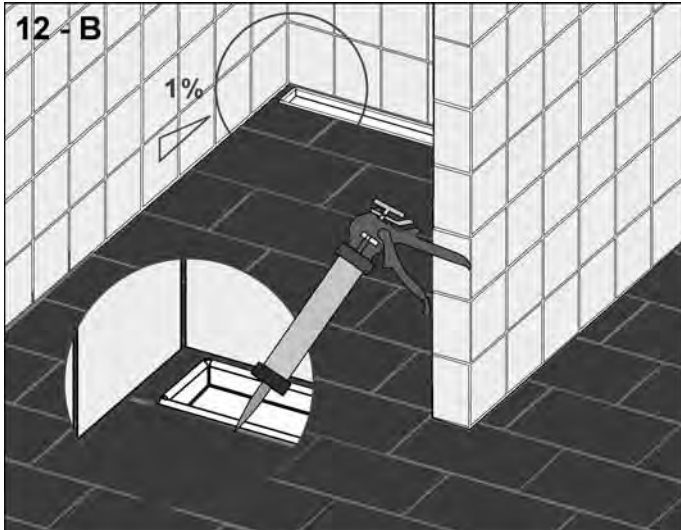

(B = position against the wall)

Seal the joint between the stainless steel channel and the tiles or natural stone with permanently flexible material, check the incline.

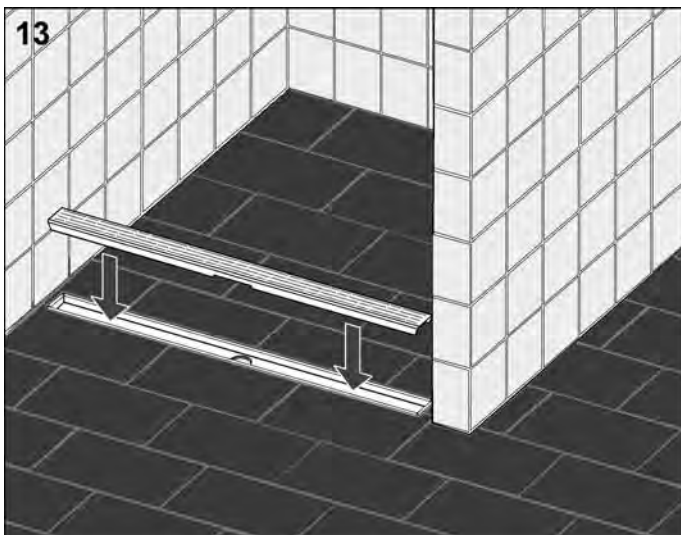

Remove the building protection material and fit in the cover.

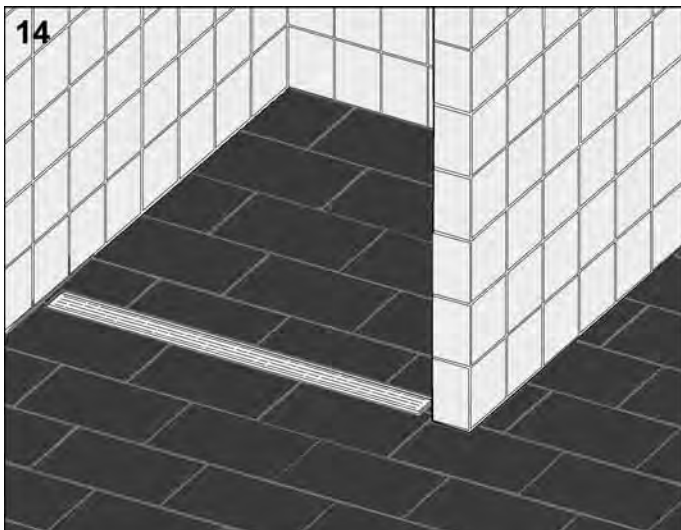

The cover should lie in the shower channel at floor level.

TECEdrainline – installation instructions

Angled channel installation instructions

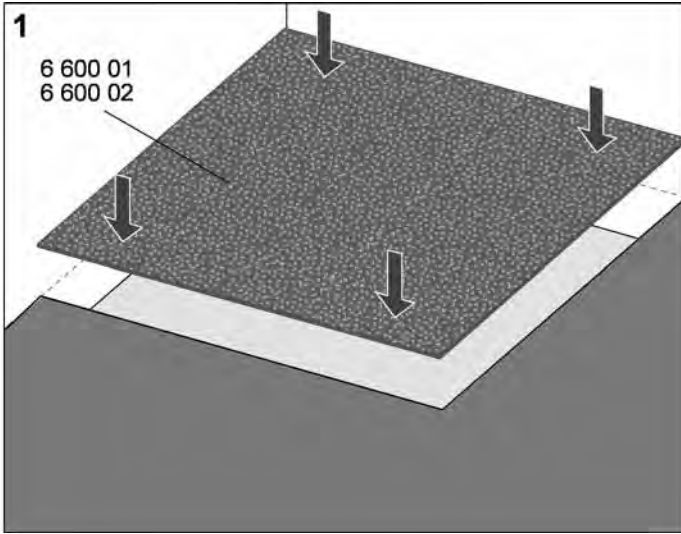

Optional: Cut the drainline sound-proofing mat and put it in position so that it covers the whole surface of the shower area.

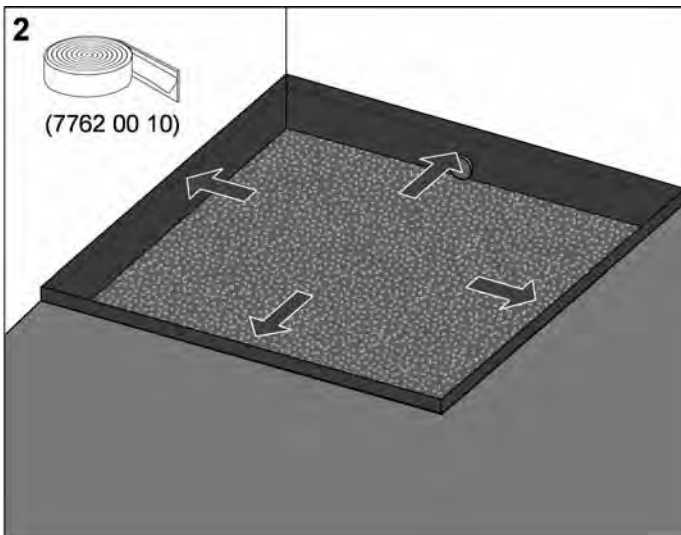

Apply edge insulation strips.

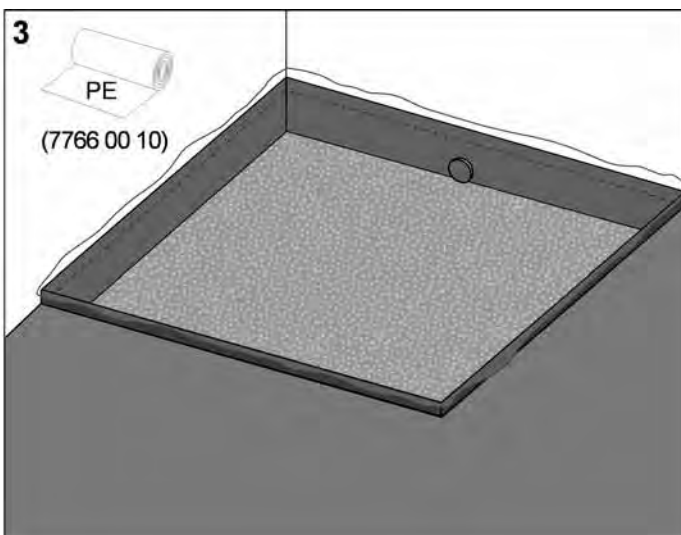

Lay the PE film.

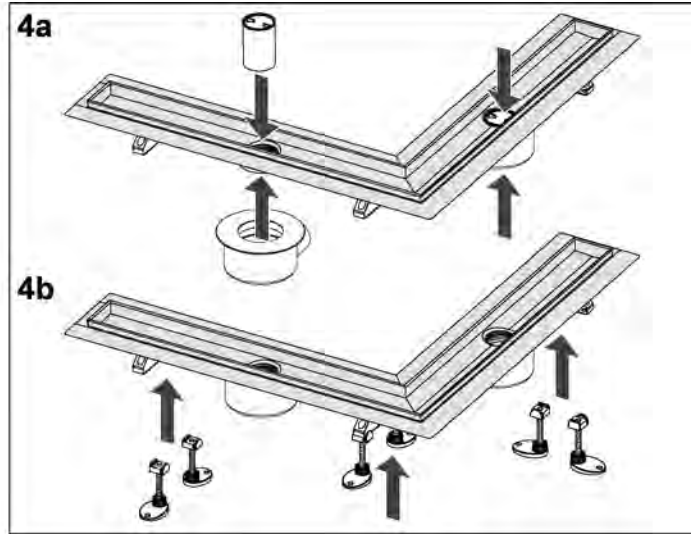

Install the outlet and the immersion pipe, if necessary clip on the mounting feet.

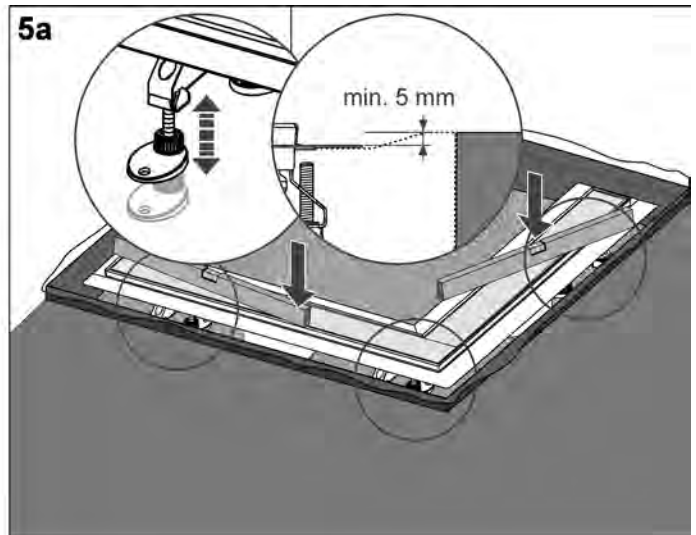

Move the shower channel into the correct position and use the adjustable mounting feet to align horizontally.

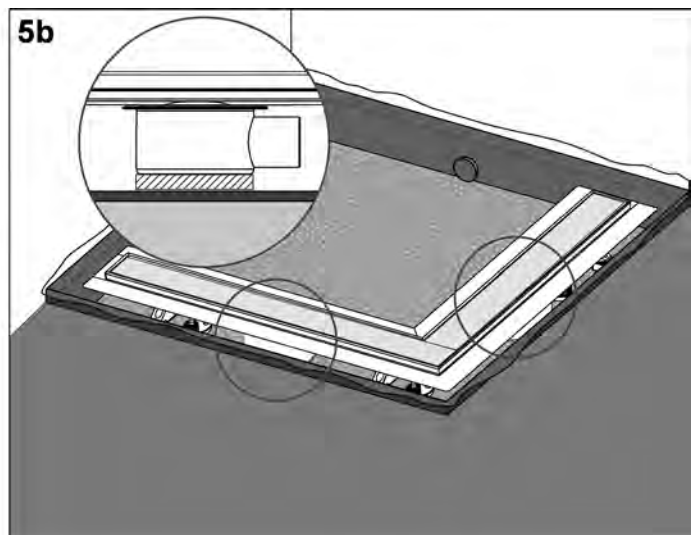

If necessary underfill the drain bowl.

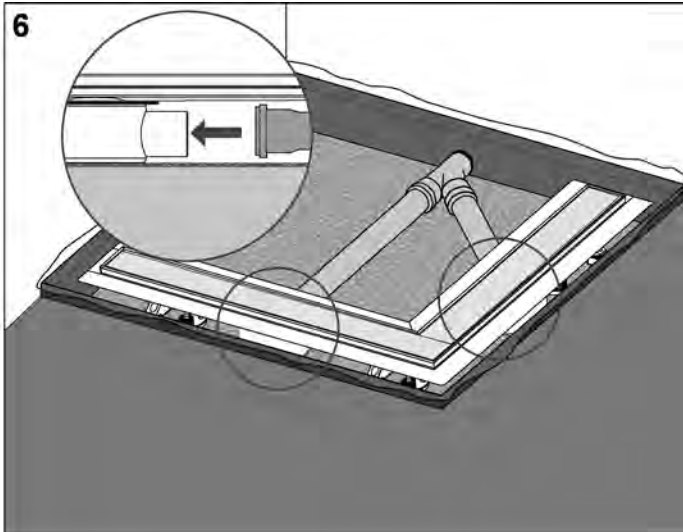

Secure the waste water pipe to the outlet socket.

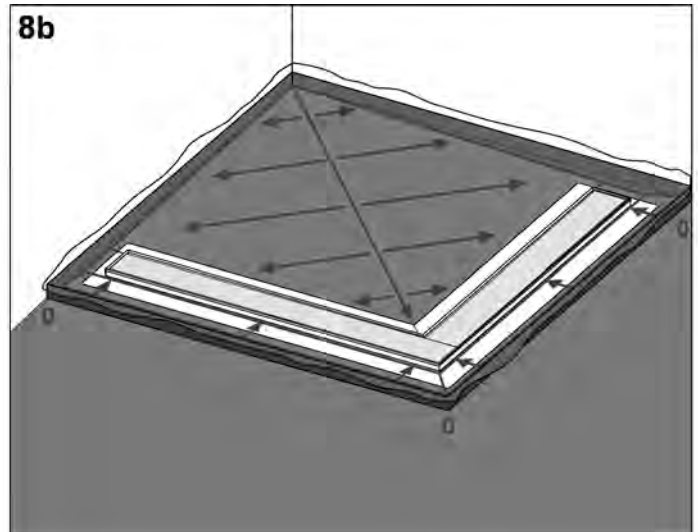

Make the slopes as described above.

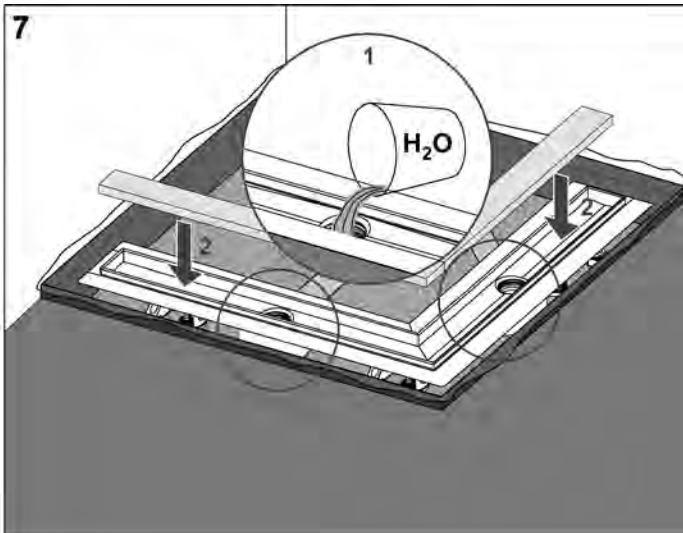

Take out the bare wall protection system and test for leaks.

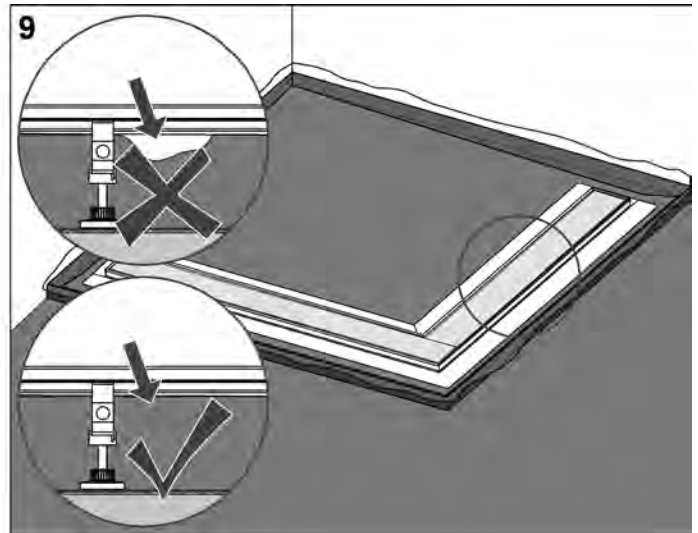

There must be no cavities at all between the screed and the channel or outlet!

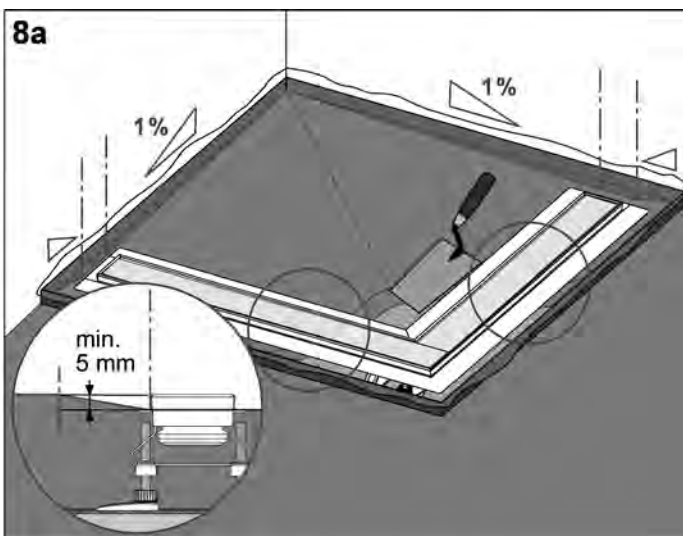

Lay screed with the required incline – in the shower area – at least one percent to both arms. The rise should be at least 5 mm.

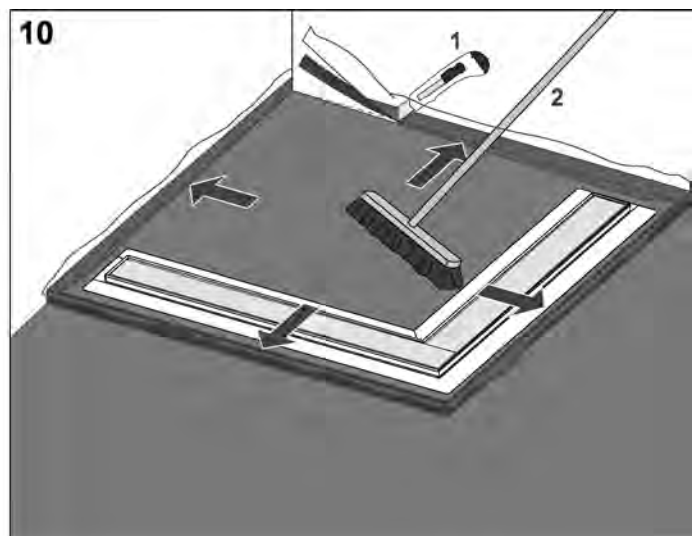

Cut off projecting edge insulation strips and PE film, clean the screed.

TECEdrainline – installation instructions

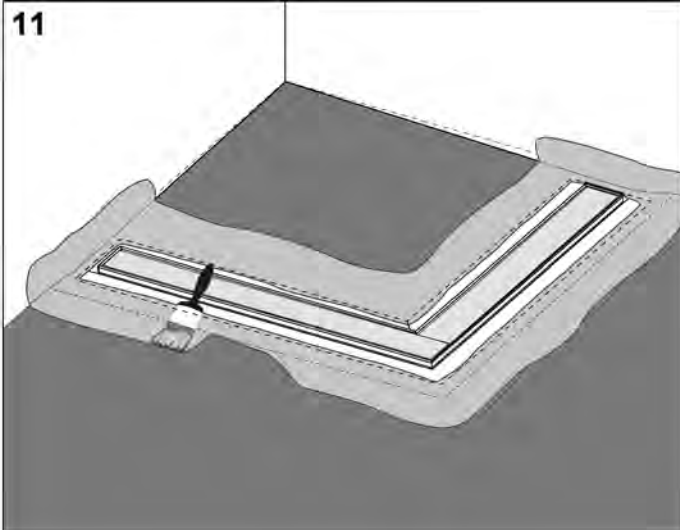

Apply sealing coating in the area of the shower channel.

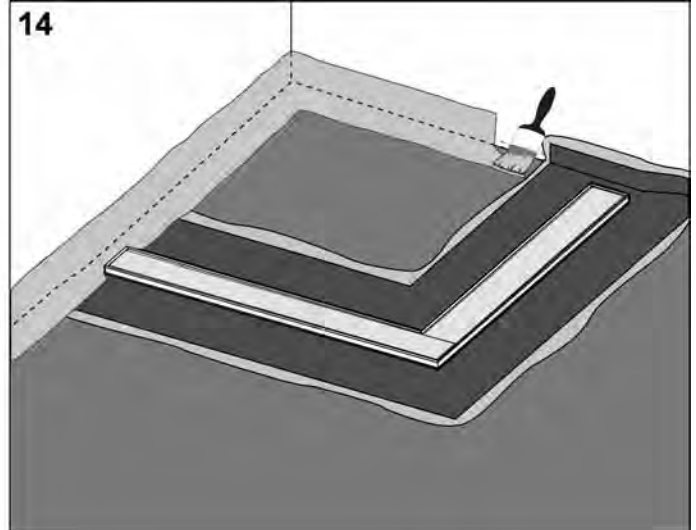

Apply a sealing coating to the transitions between the wall and the floor.

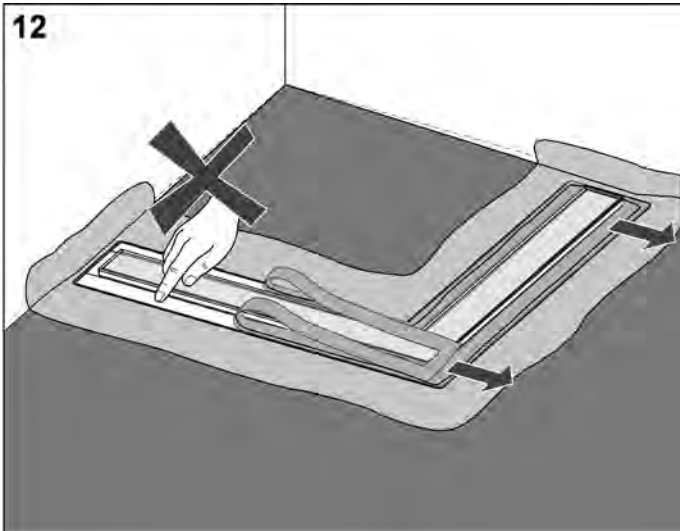

Pull off the protective film from the flange, do not touch the adhesive layer any more.

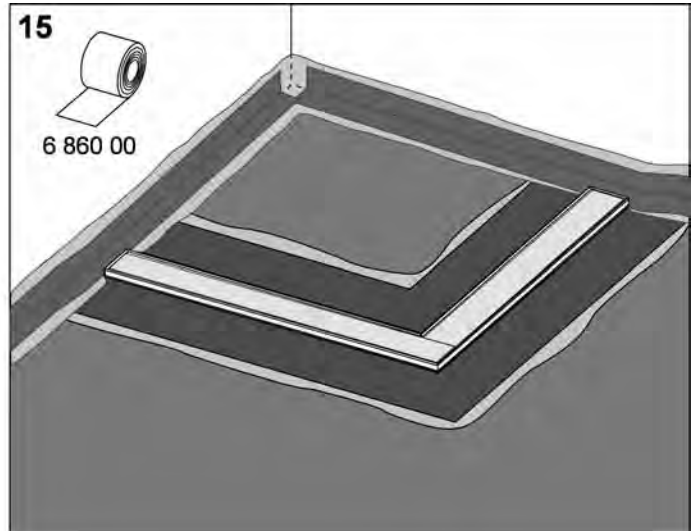

Apply sealing tape bubble-free.

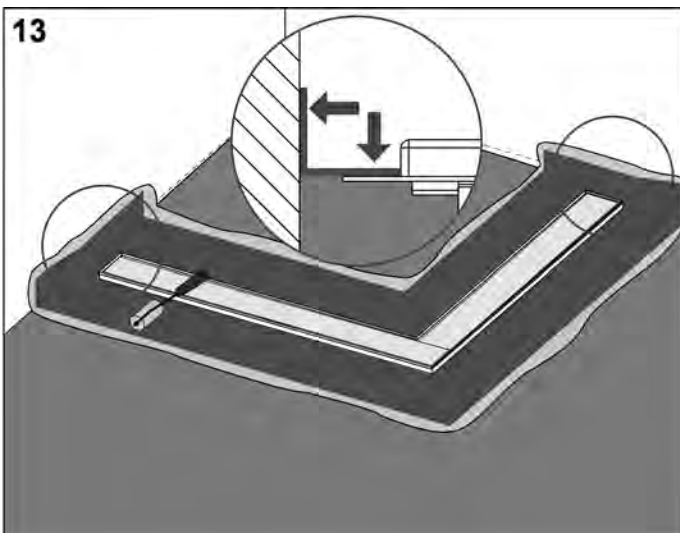

Stick on the supplied sealing material bubble-free in the floor area and the wall area.

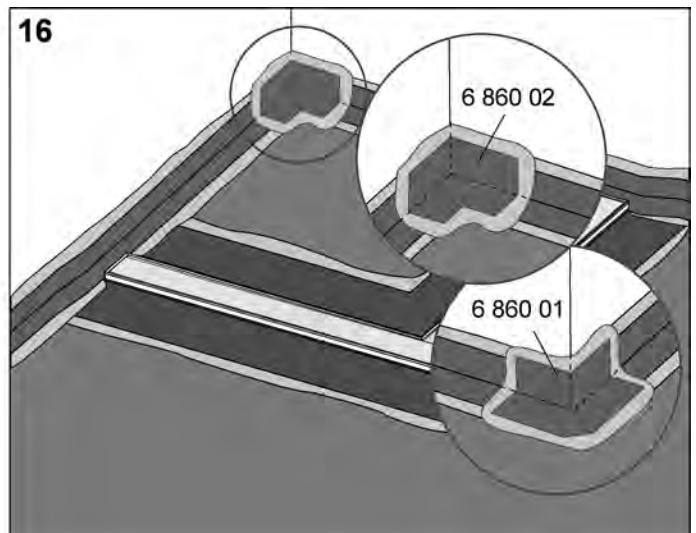

Brush sealing coating onto the corners and transitions and glue on sealing material (e.g. pre-prepared sealing corners).

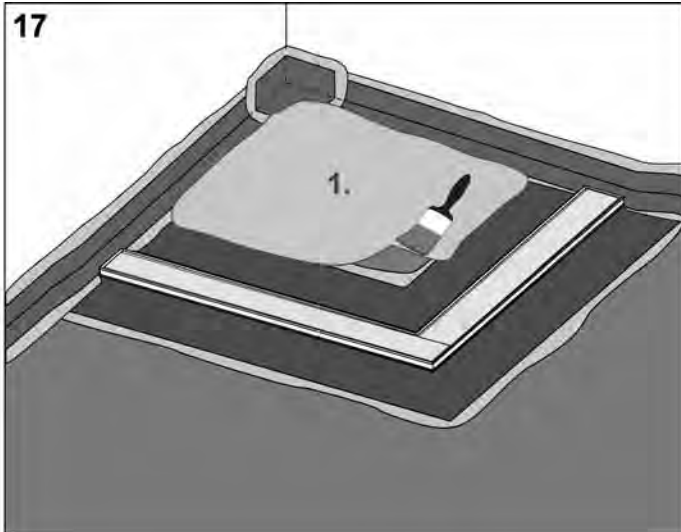

Apply the first sealing coating over the whole of the shower area according to the manufacturer's specifications.

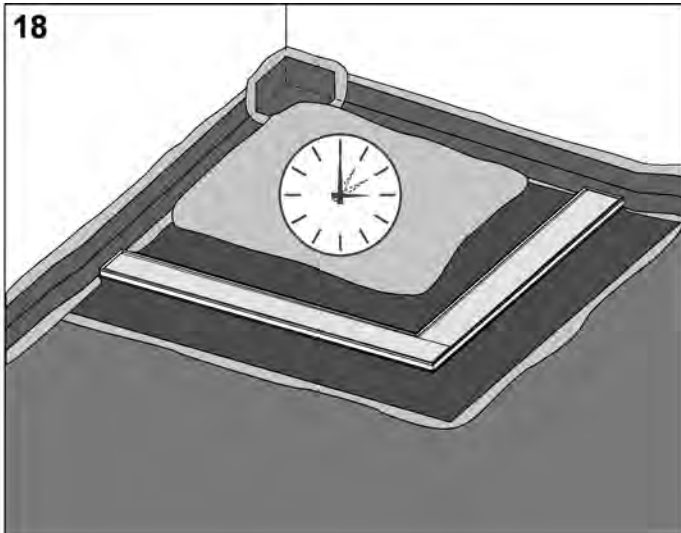

Wait for the specified drying time.

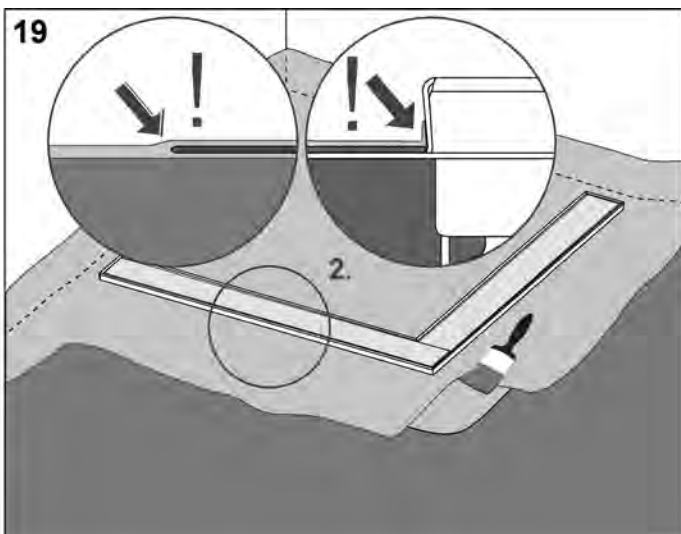

Apply the second sealing coating over the whole of the shower area according to the manufacturer's specifications. Important: The sealing material must be included in the sealing coating.

TECEdrainline – installation instructions

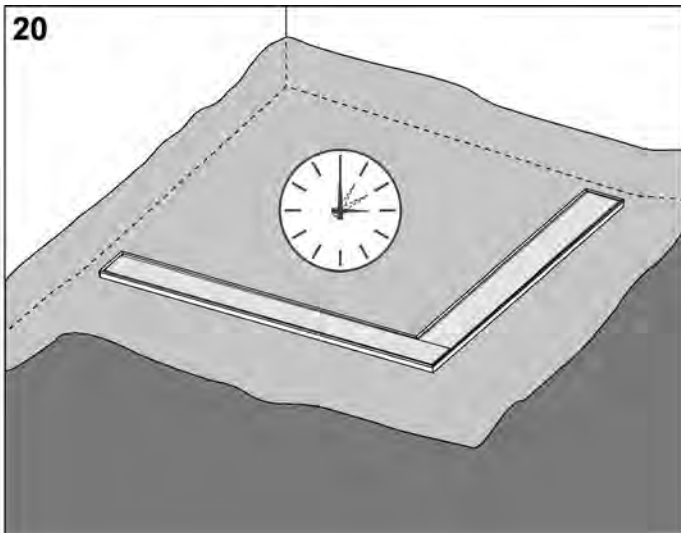

Wait for the specified drying time.

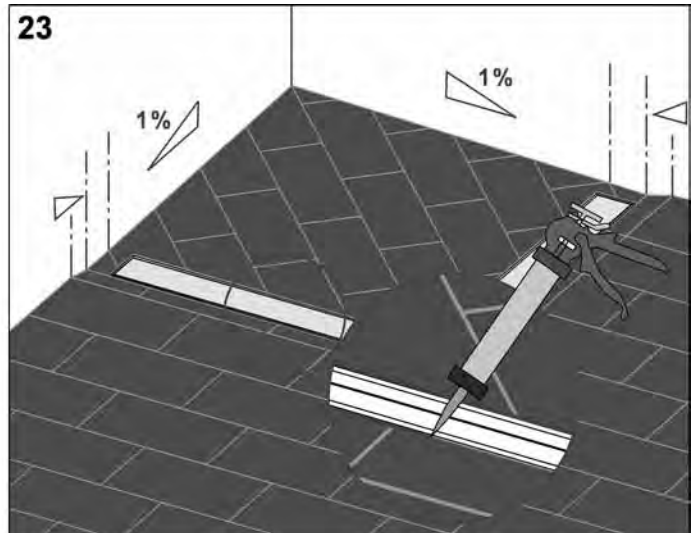

Seal with permanently flexible expansion joints.

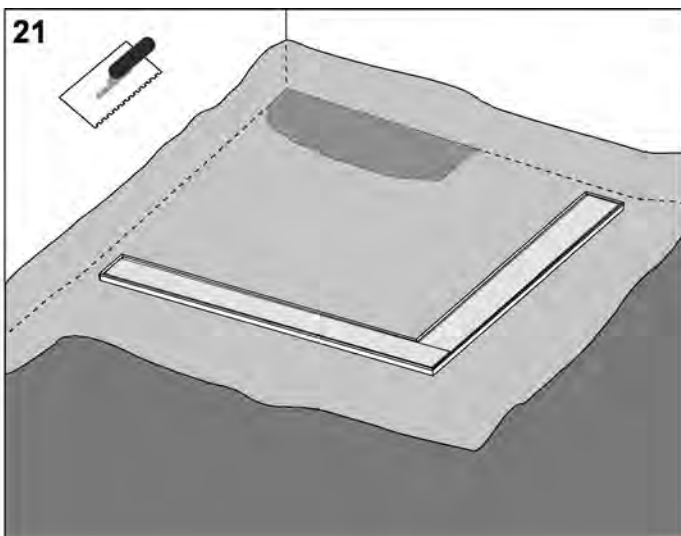

Apply tile adhesive.

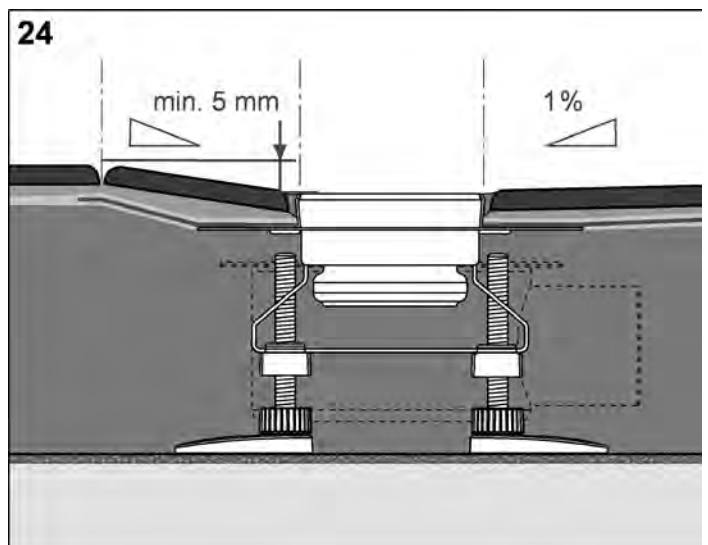

Check the incline and rises.

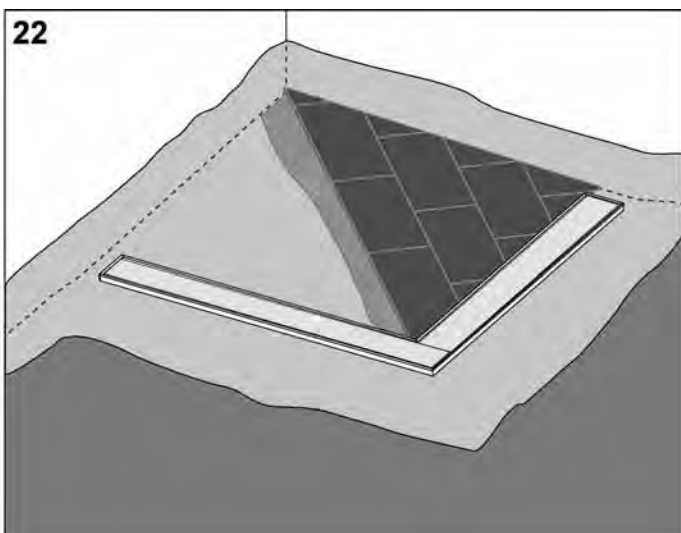

Lay the floor covering (tiles or similar), in doing so, keep to the specified falls without incline.

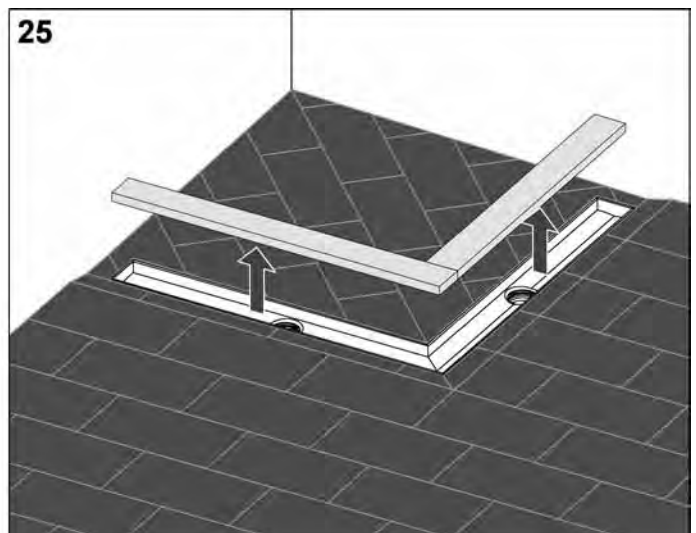

Remove the bare-wall protection system, clean the channel.

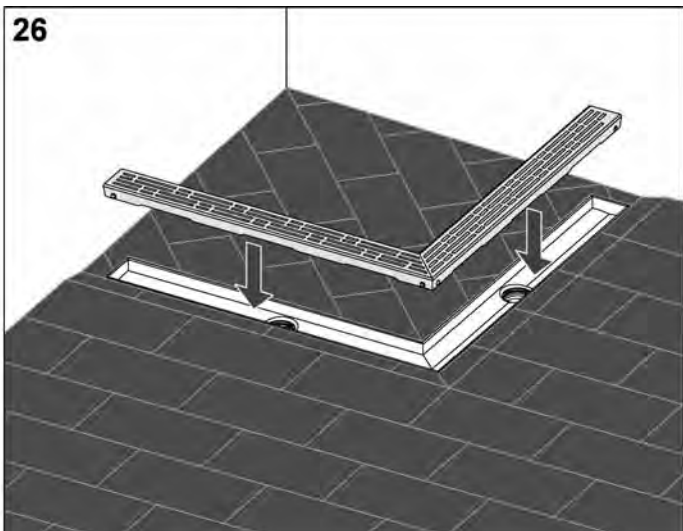

Insert the desired cover (patterned grate, glass cover, tileable channel).

TECEdrainline – installation instructions

Shower channel for natural stone installation instructions

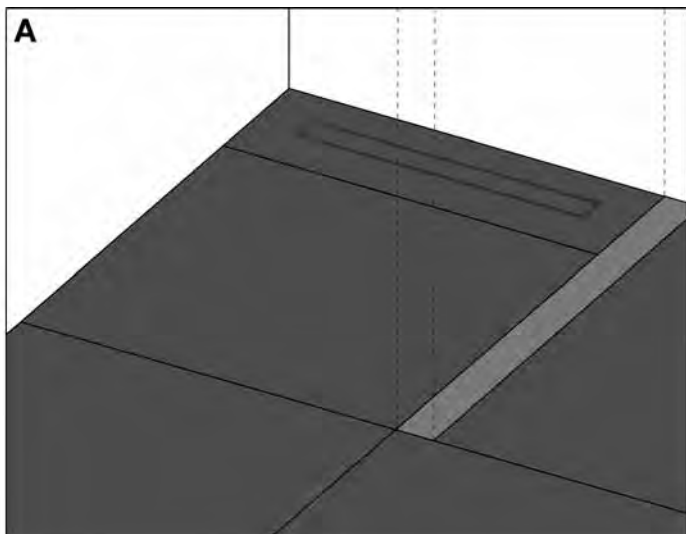

Positioning the shower channel at the wall (A).

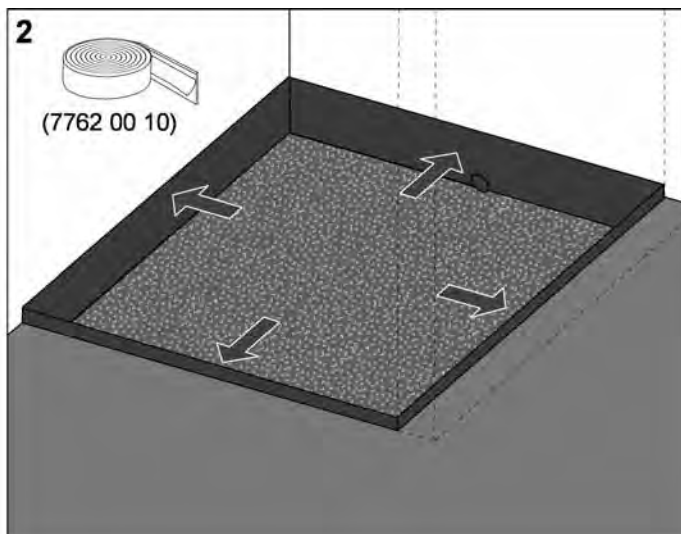

Apply edge insulation strips.

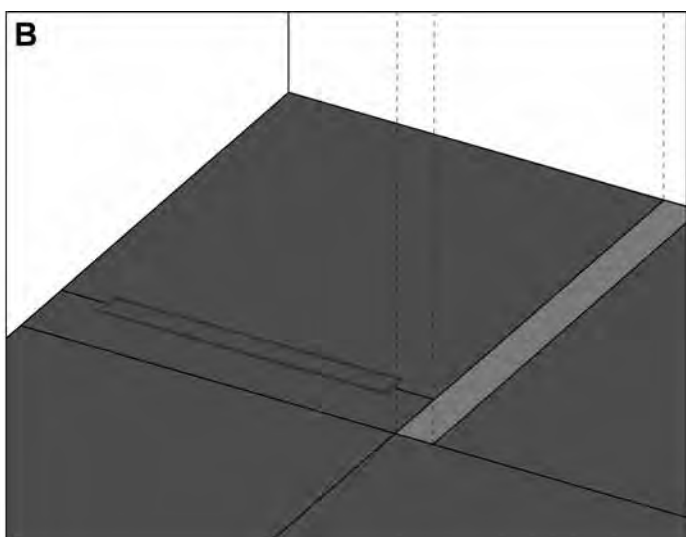

Positioning the shower channel towards the middle of the room (B)

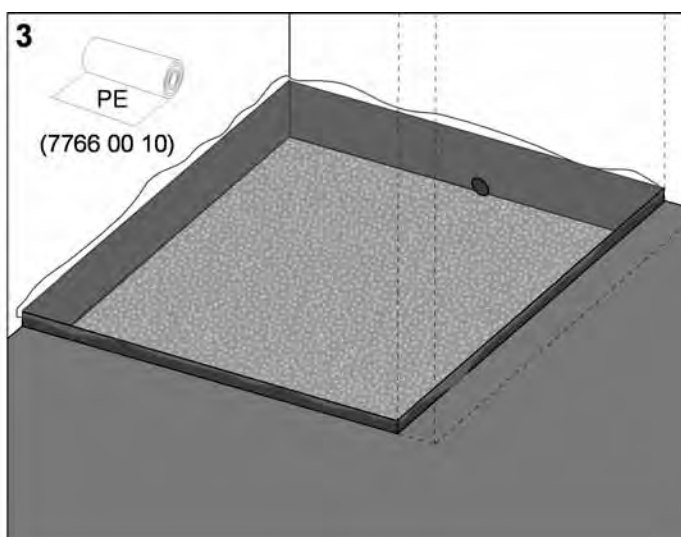

Lay the PE film.

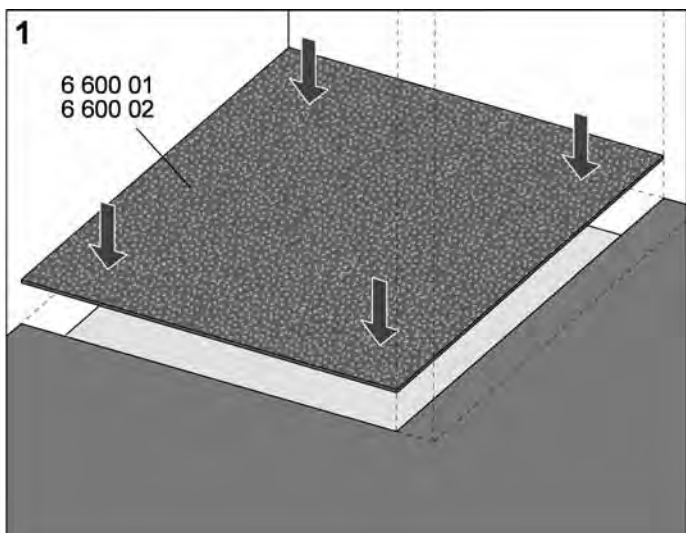

Optional: Cut the drainline sound-proofing mat and put it in position so that it covers the whole surface of the shower area.

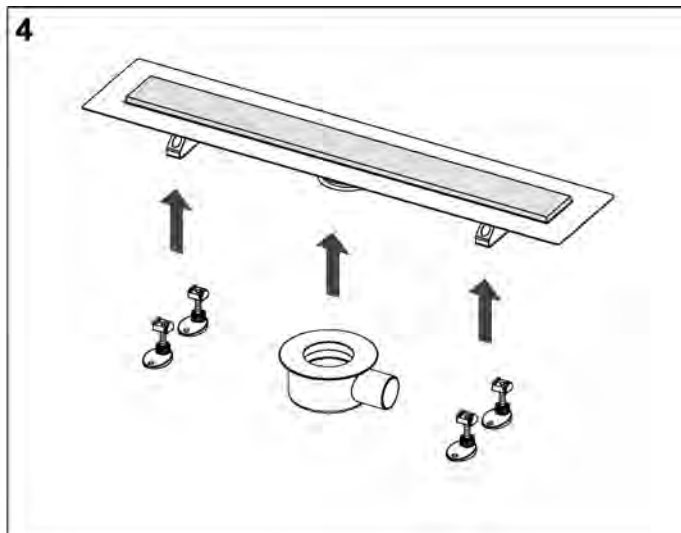

Install the outlet and if necessary clip in the mounting feet.

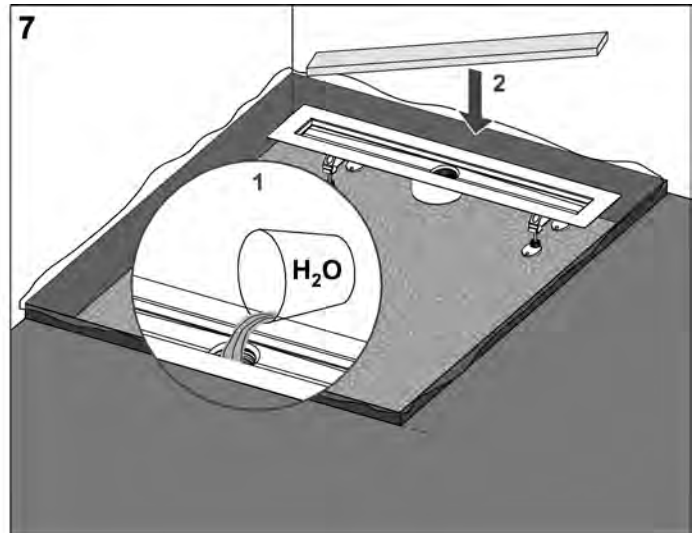
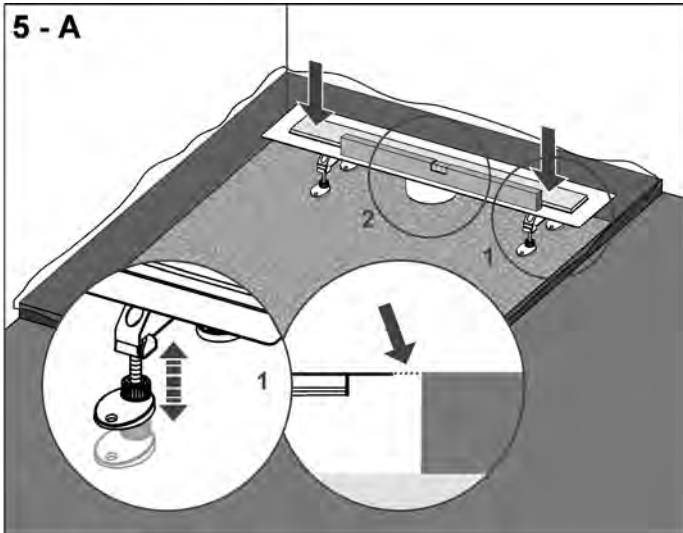

Test for leaks and insert the bare-wall protection system again.

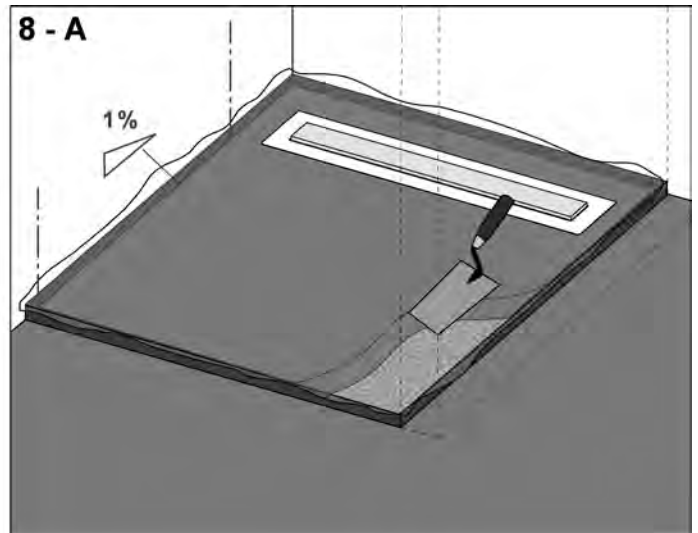
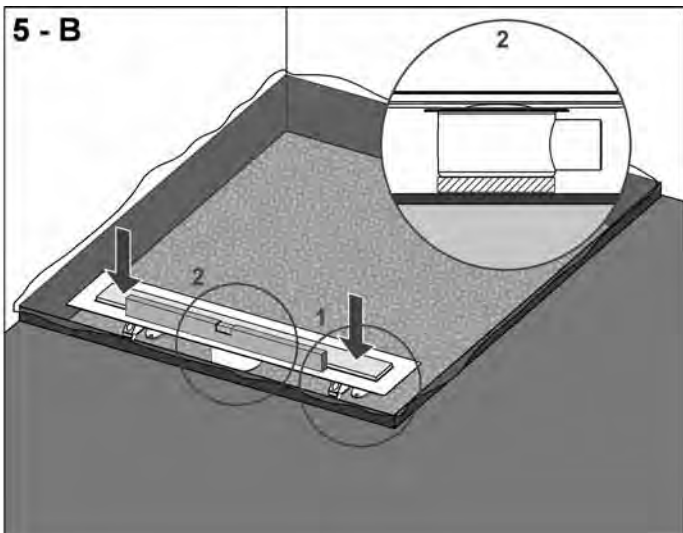

Move the shower channel into the correct position and use the adjustable mounting feet to align horizontally. If necessary underfill the drain bowl.

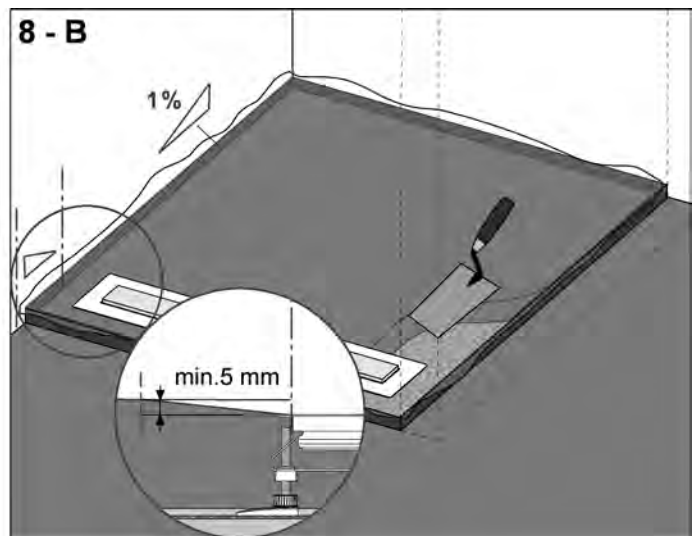
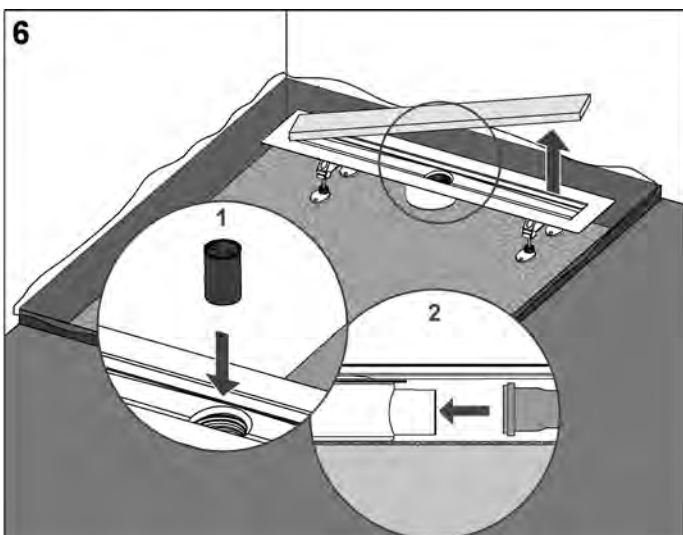

Take out the bare-wall protection system, insert the immersion pipe and secure the waste water pipe to the outlet socket.

Lay screed with the required incline of at least one percent to the edge of the shower channel. When installing towards the middle of the room (B), the rise must be at least 5 mm.

TECEdrainline – installation instructions

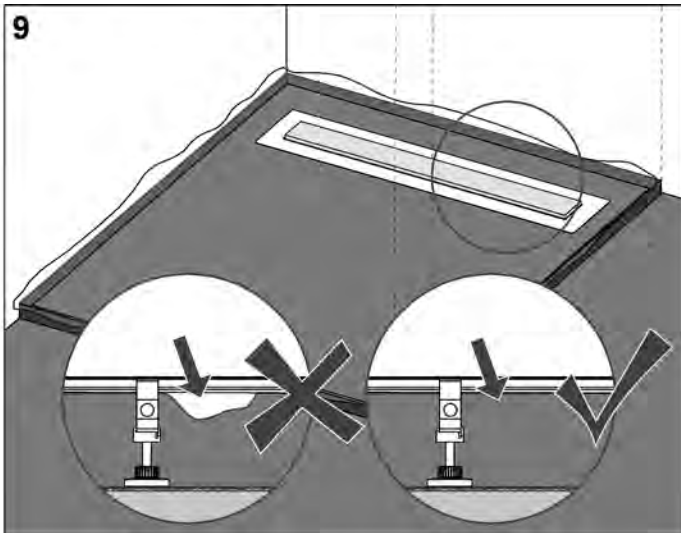

There must be no cavities at all between the screed and the channel or outlet!

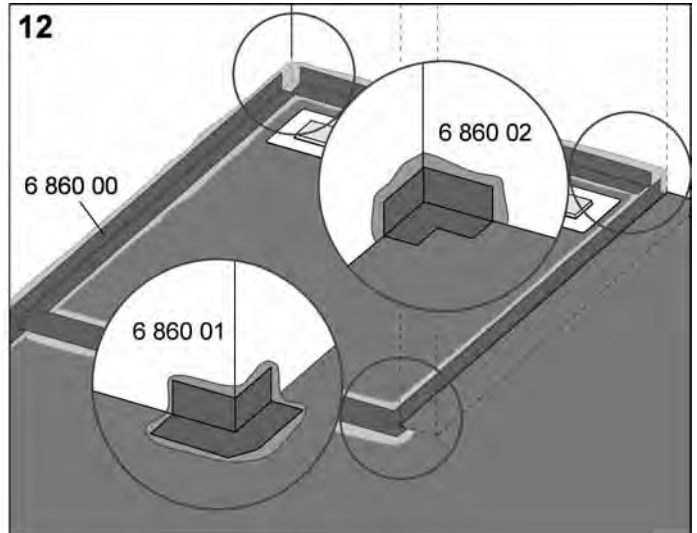

Apply sealing tape bubble-free. Brush another sealing coating onto the transitions and corners and glue on sealing material (e.g. pre-prepared sealing corners).

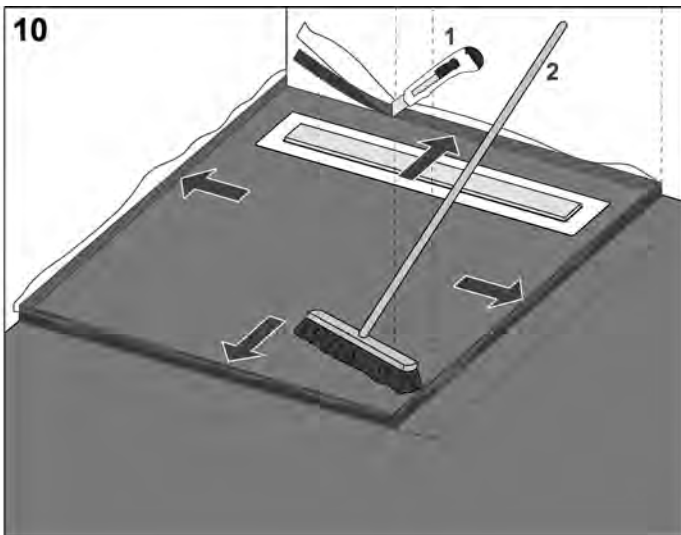

Cut off projecting edge insulation strips and PE film, clean the screed.

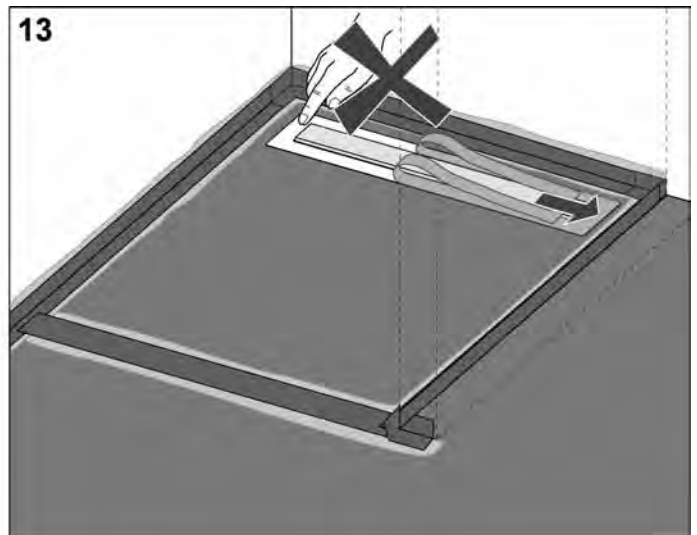

Pull off the protective film from the flange, do not touch the surface any more.

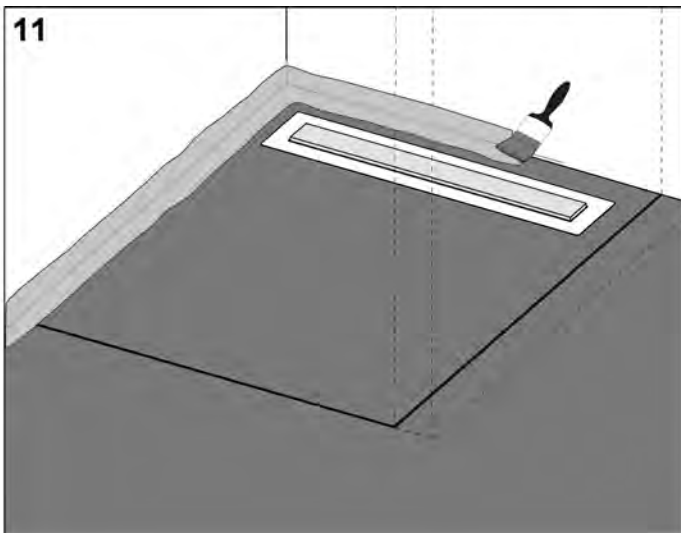

Apply a sealing coating to the transitions between the wall and the floor.

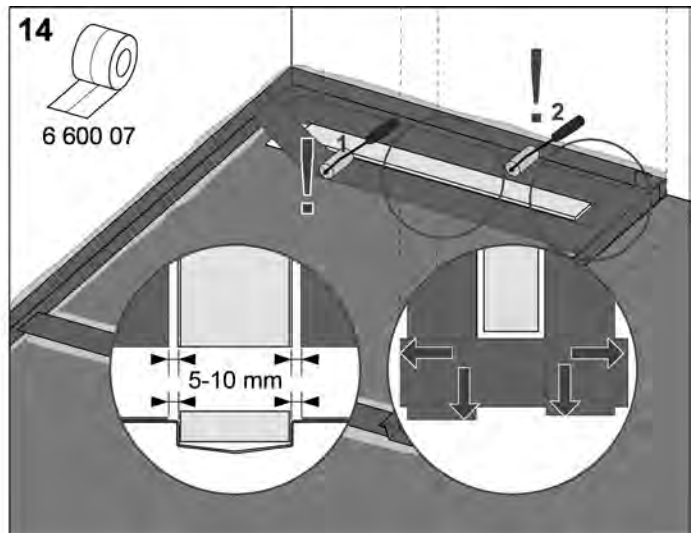

Apply self-adhesive sealing tape overlapping onto the flange and screed, clearance to the channel body 5-10 mm.

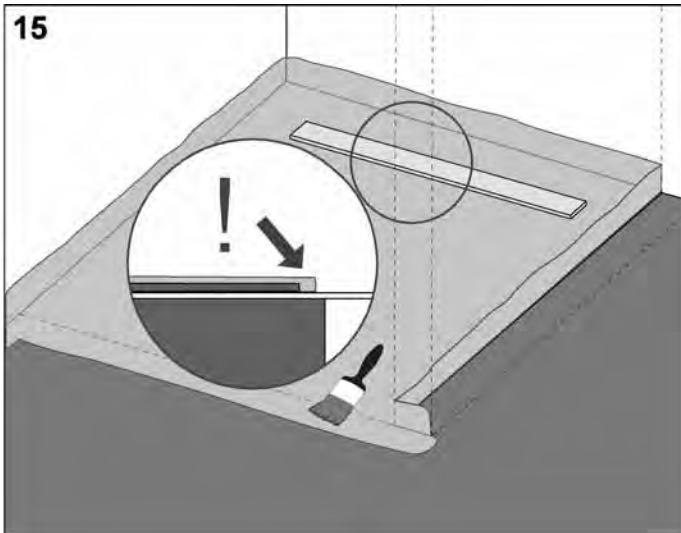

Apply the first and second sealing coatings according to the manufacturer's specifications, allow sufficient drying times. The sealing tape must be completely enclosed by the sealing coating.

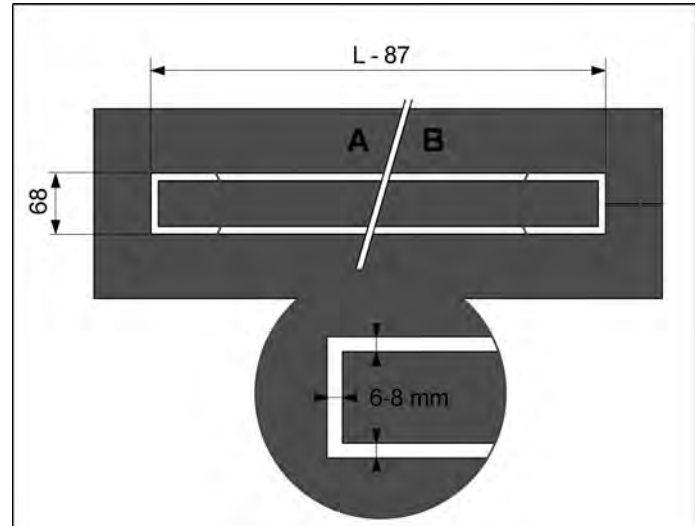

It is best to use a water cutter to make cut-outs in the covering. The gap width must be between 6 and 8 mm!

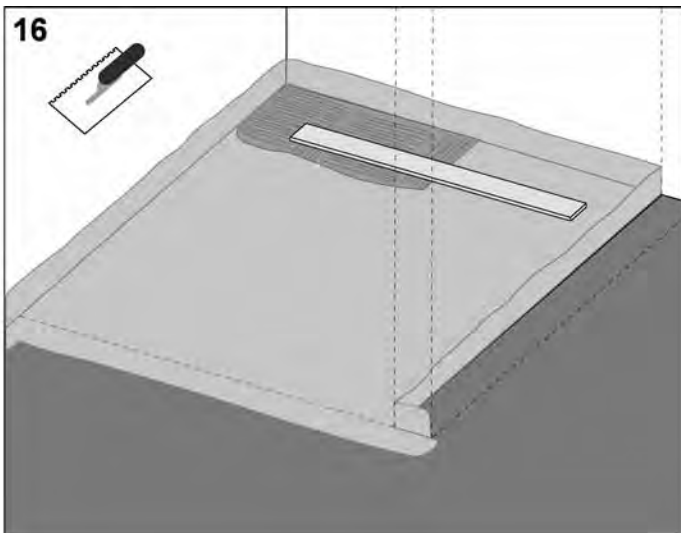

Apply tile adhesive.

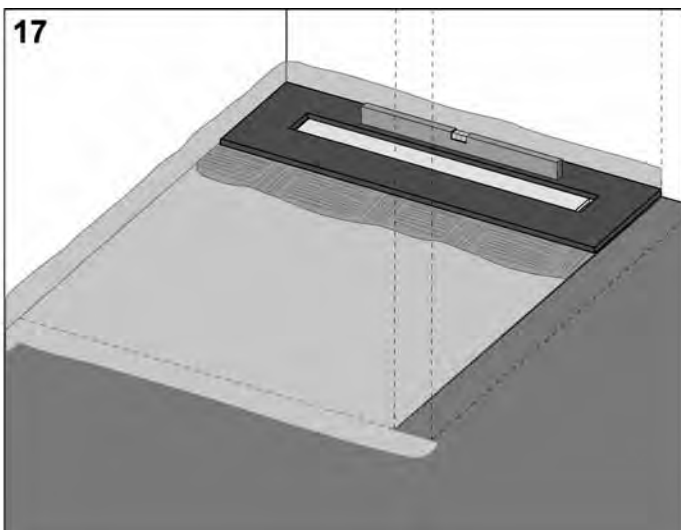
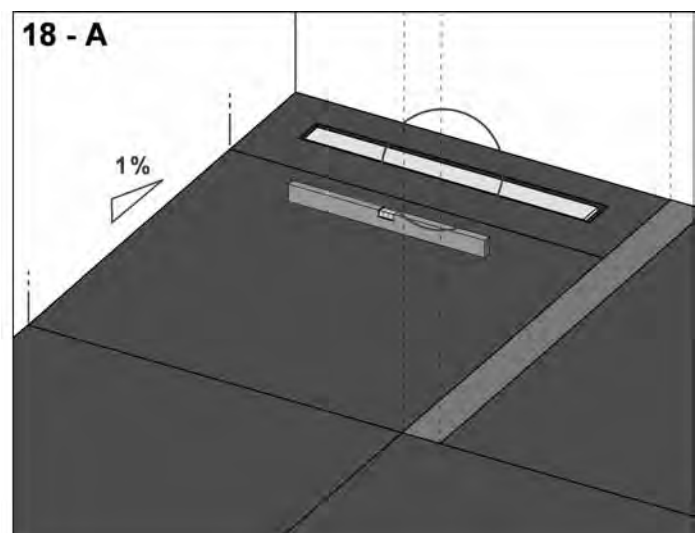

Lay the floor covering (e.g. natural stone flags) around the shower channel and align horizontally.

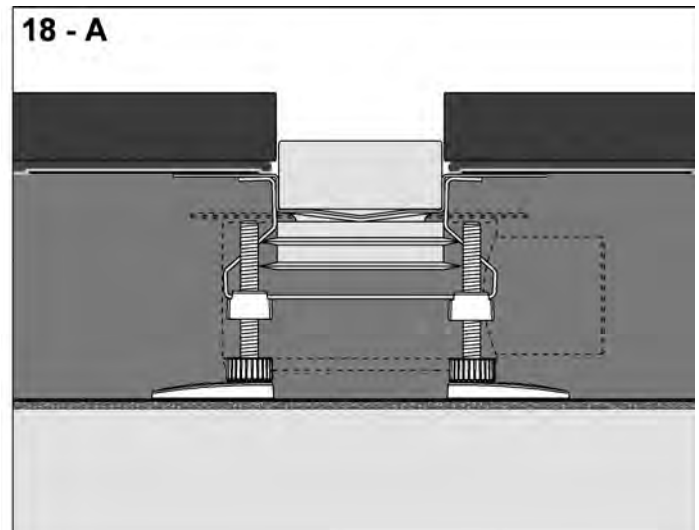

Installation situation against the wall (A): Lay the floor covering in the rest of the shower area with the required incline of at least one percent to the shower channel.

TECEdrainline – installation instructions

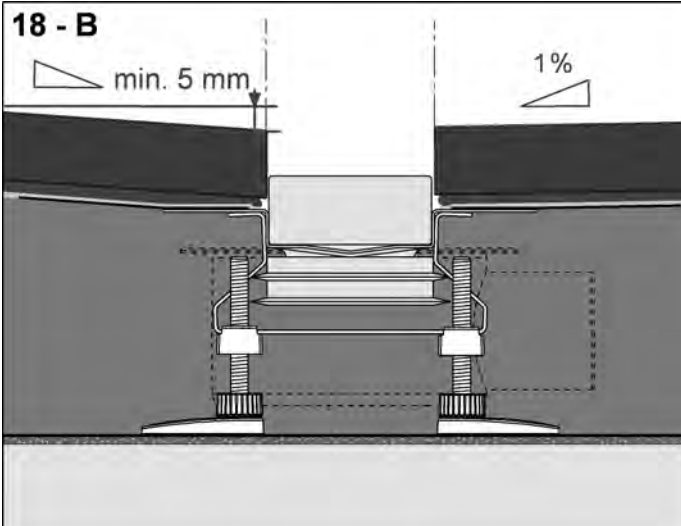
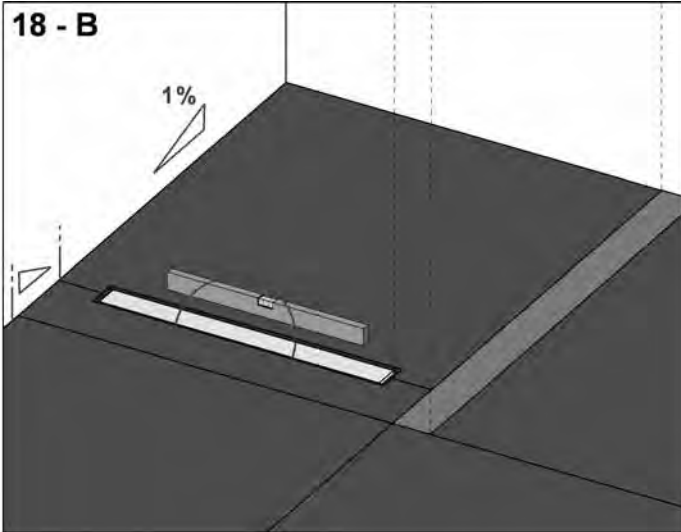

Installation situation towards middle of the room (B): Lay the floor covering in the rest of the shower area with the required incline of at least one percent to the shower channel. The rise must be at least 5 mm.

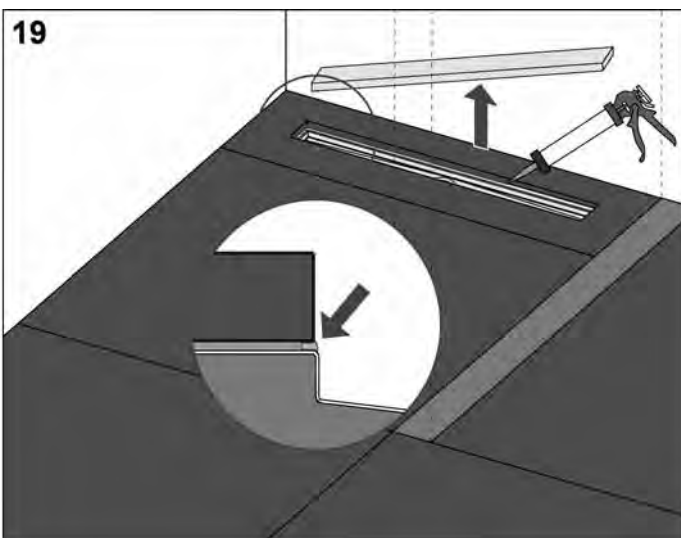

Seal the intermediate space between the floor covering and the screed with permanently flexible material.

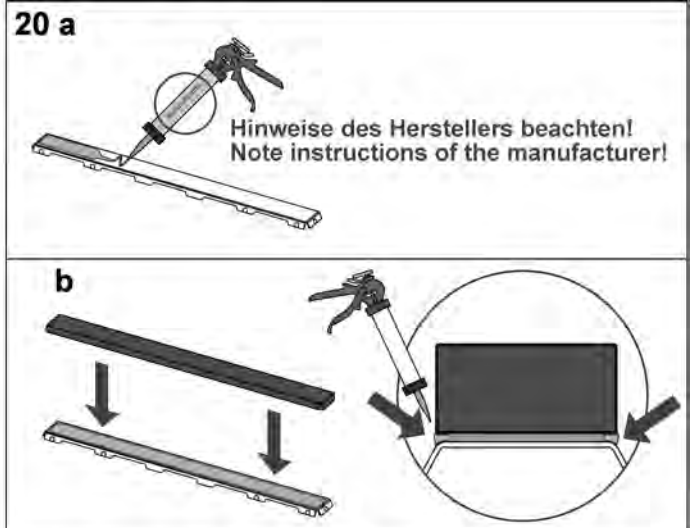

Cut the covering to size and use a suitable adhesive to bond it to the support (follow the manufacturer's instructions). Seal the intermediate space between the bonded covering and the support with permanently flexible material.

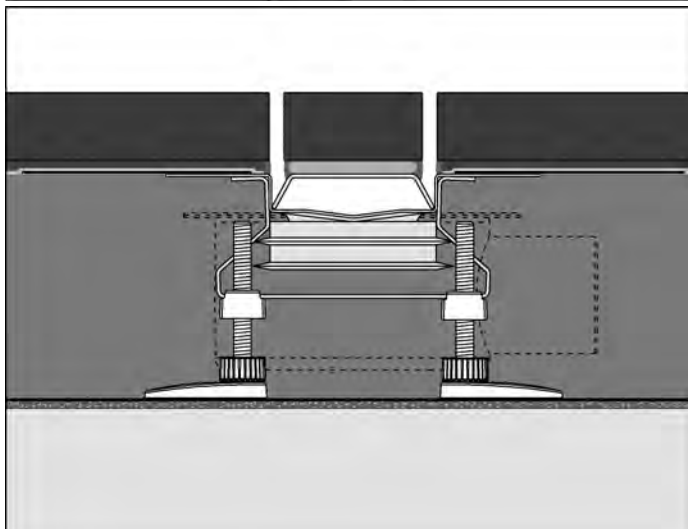
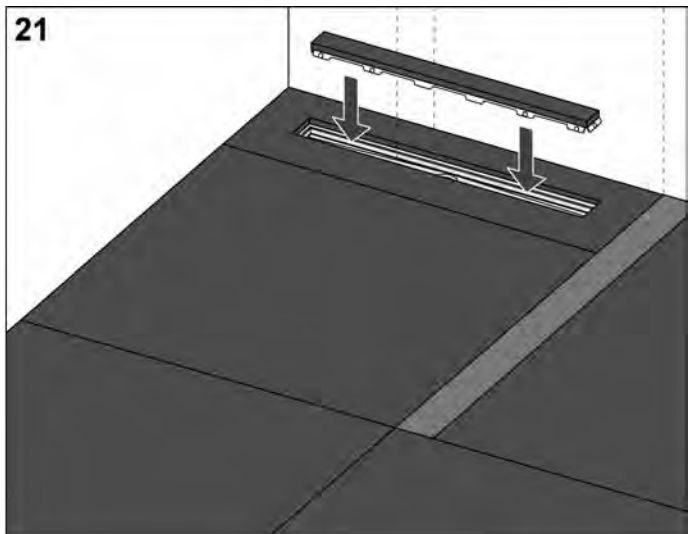

Clean the shower channel and insert the support into it, check the gap dimensions.

Super-flat outlet installation instructions

The installation of a shower channel using a super-flat outlet is done in basically the same way as with another horizontal drainline outlet.

There are some points to pay attention to however, because of the super-flat construction.

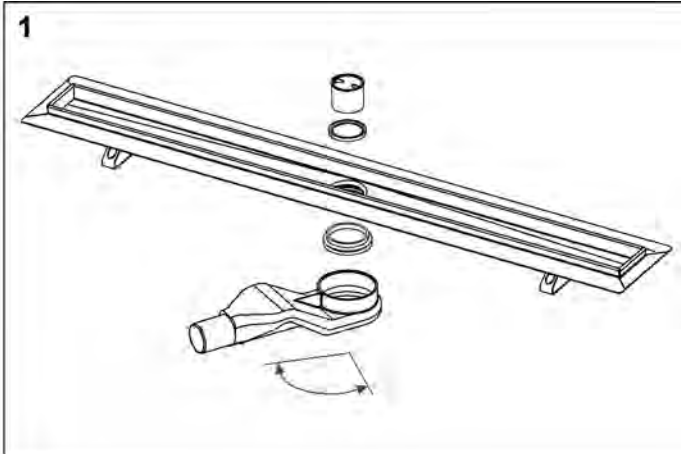

Put the outlet on the channel body.

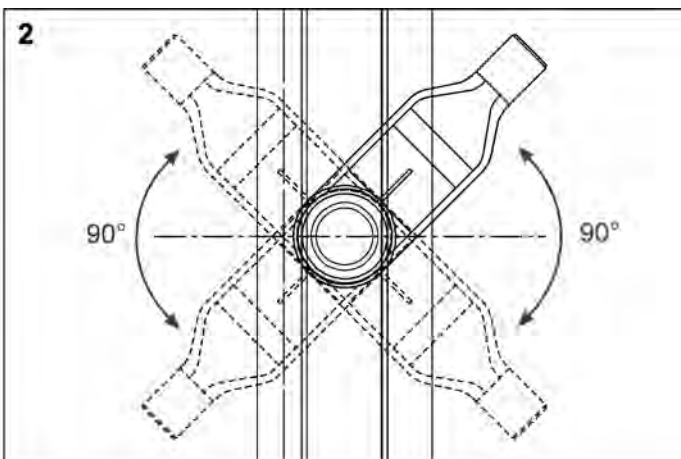

The turning range of the super-flat outlet is about 90° to either side of the shower channel.

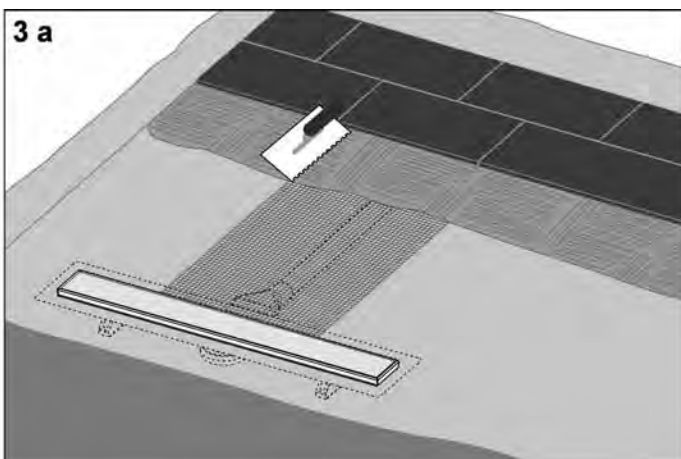

Because of the partially limited screed covering, an adequately wide armoring net must be included in the area of the outlet and the drain pipe.

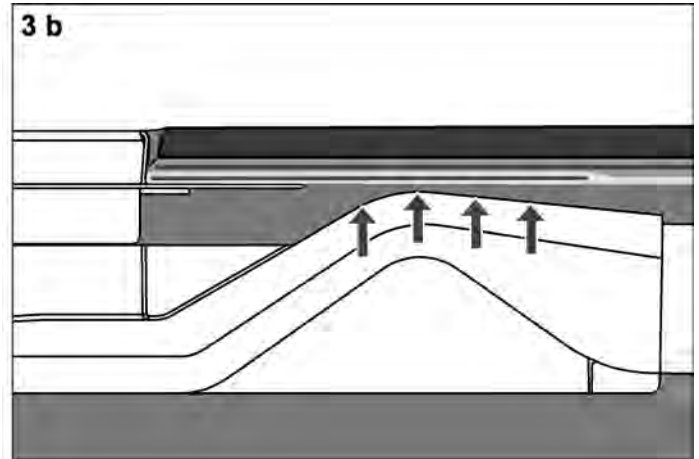

There should be no joint running in the marked area above the drain body.

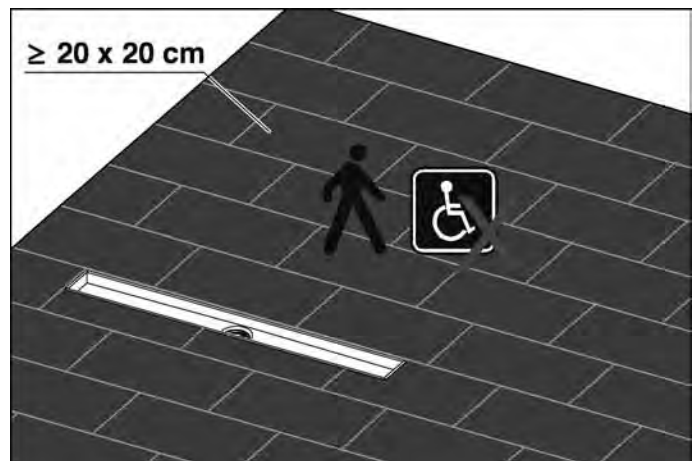

When choosing the floor covering, it must be taken into account that only flags each with an edge length of 20 cm or more may be used. A wheel chair must not be allowed to run over the shower area.

Vertical outlet installation instructions

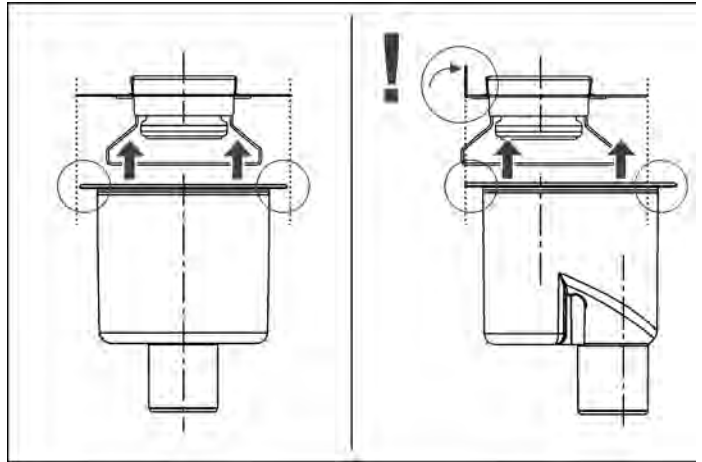
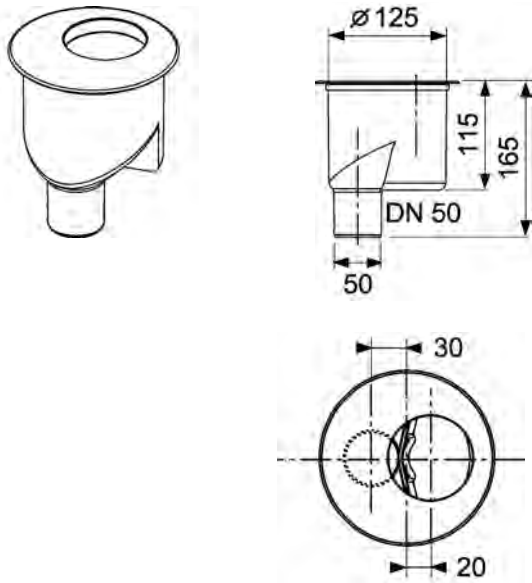

When installation is close to a wall, the flange must be flush with the edge of the outlet.

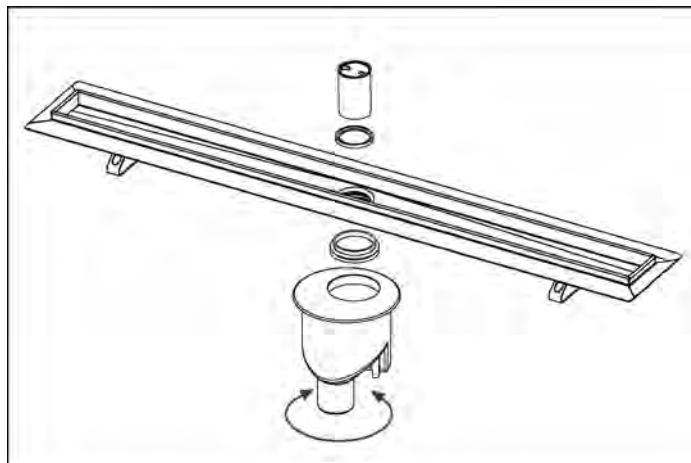

Secure the outlet to the shower channel.

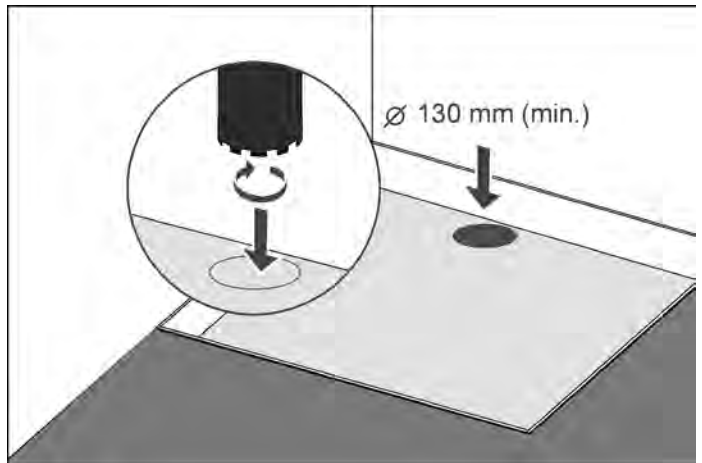

Make a core bore with $\varnothing 130 \text{ mm}$.

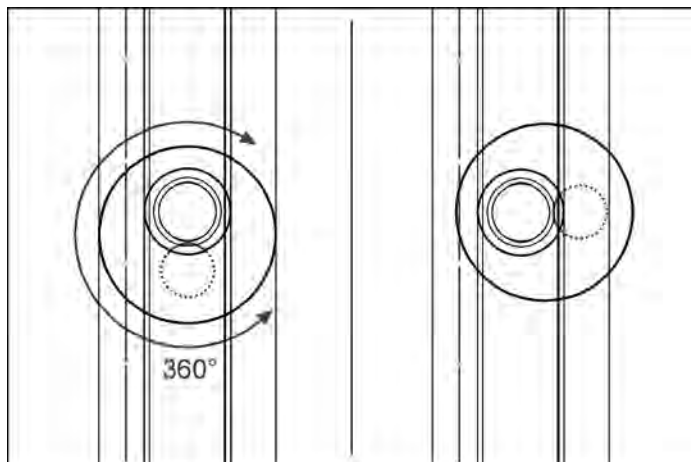

When the installation is near a wall, the body of the outlet bowl can be turned. It is therefore not necessary to chisel into the wall.

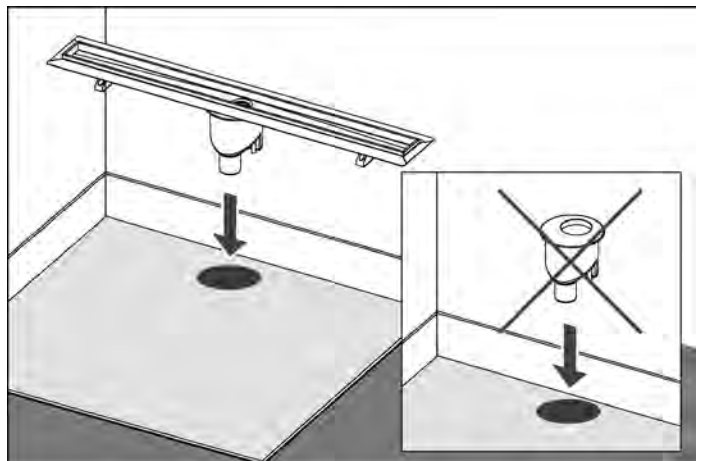

Insert the outlet bowl including shower channel into the core bore. Check for leaks! The edge of the outlet must be packed underneath with screed – there must be no cavities!

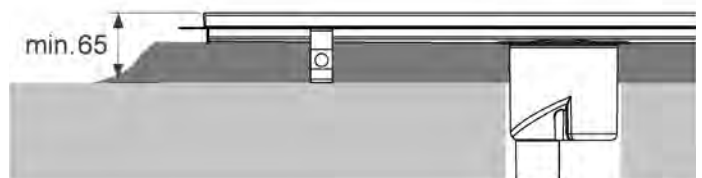

Without mounting feet, the minimum assembly height is 65 mm.

Fire protection set installation instructions

The fire protection set can only be used together with the vertical outlet (order number 6 500 03).

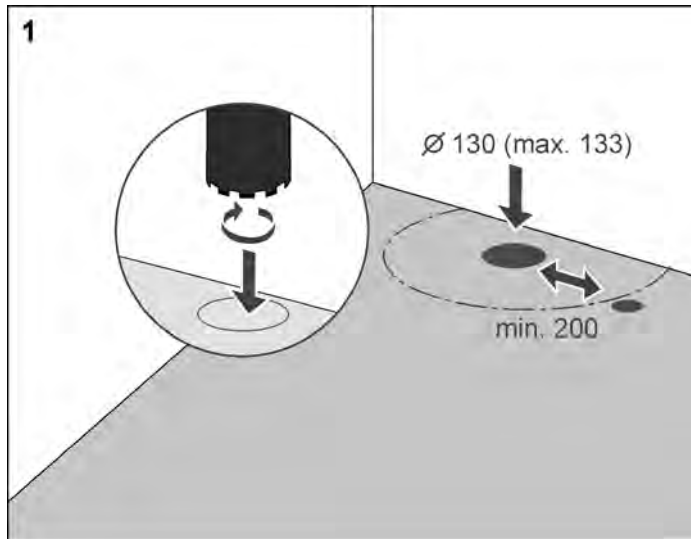
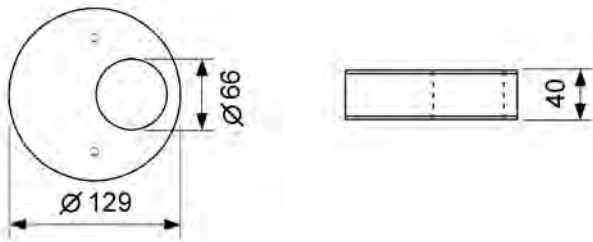

Make a core bore for the outlet, diameter 130 mm (max. 133 mm). The distance to the nearest ceiling duct must be at least 200 mm.

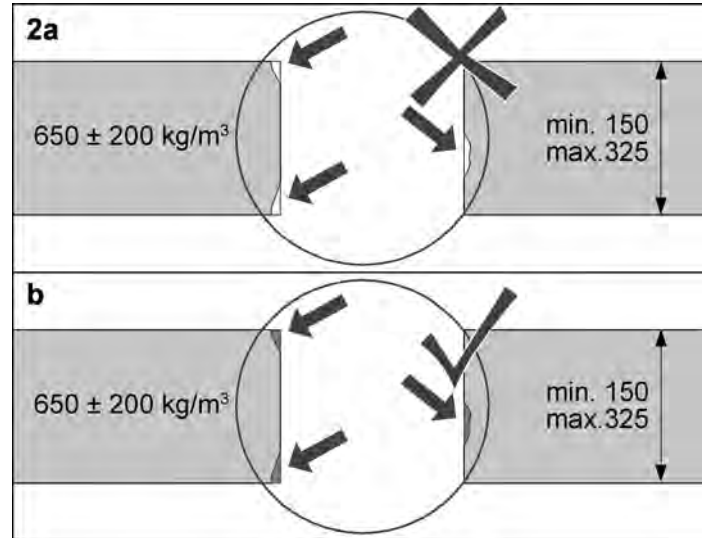

The fire protection set is only permitted for use with solid floor constructions having a density of $650 \pm 200 \text{ kg/m}^3$ and a thickness of 150 to 325 mm.

Damage along the drilled hole must be made good using a suitable material.

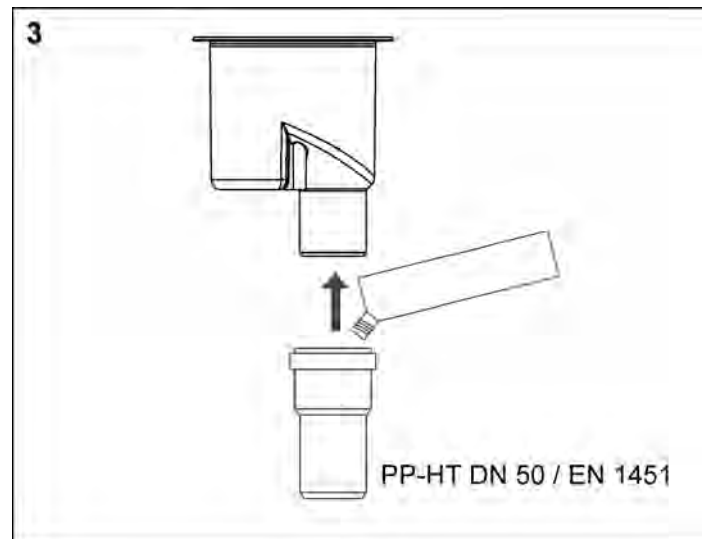

In the immediate area of the fire protection sleeve, a PP-HT pipe (to DIN EN 1451) must be used to connect the outlet to the waste water pipe.

TECEdrainline – installation instructions

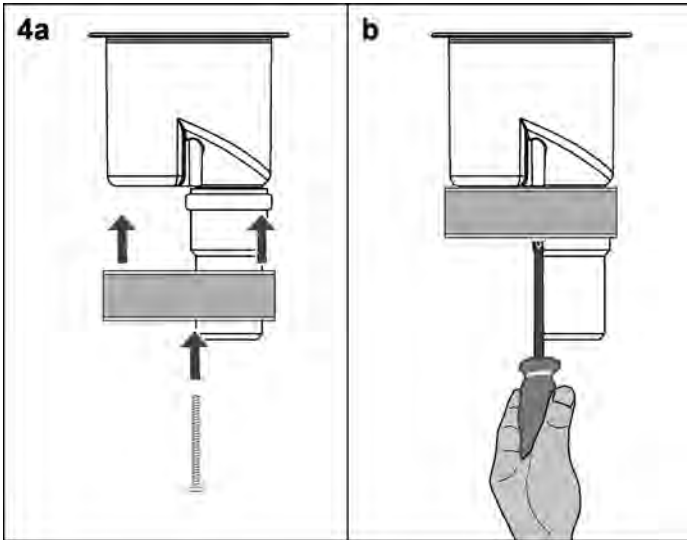

Secure the fire protection sleeve to the outlet using the two screws supplied with it.

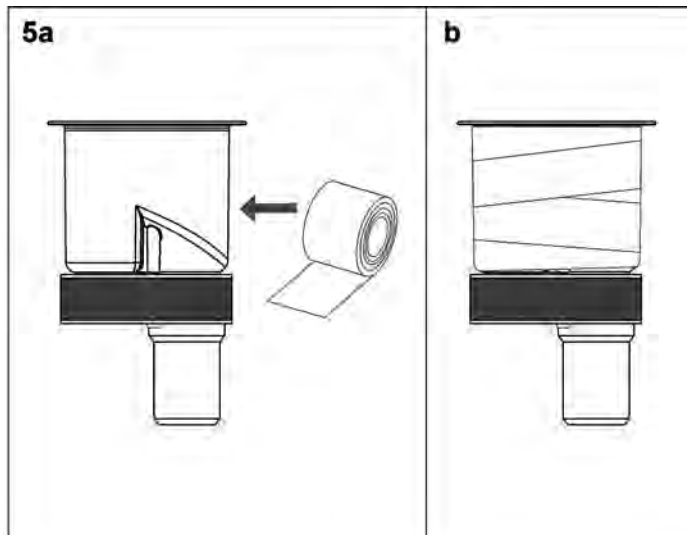

Wrap the outlet bowl with felt wrap, adhesive bandage or similar sound-absorbing material - **not the sleeve**.

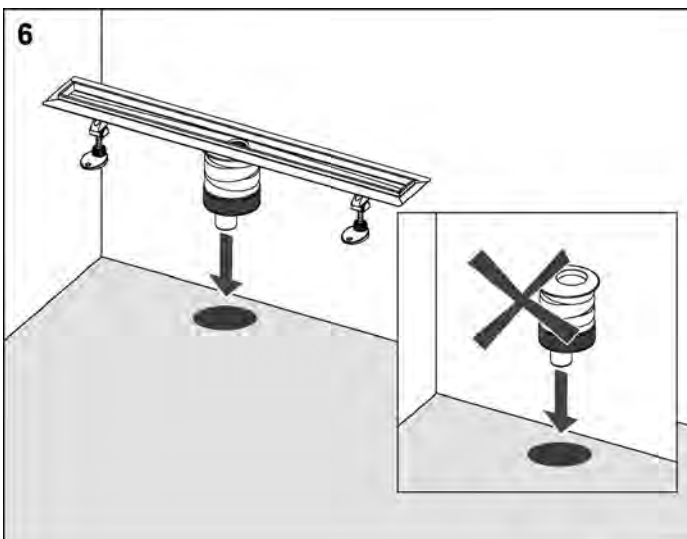

Put the outlet on the channel body and move it into the desired position.

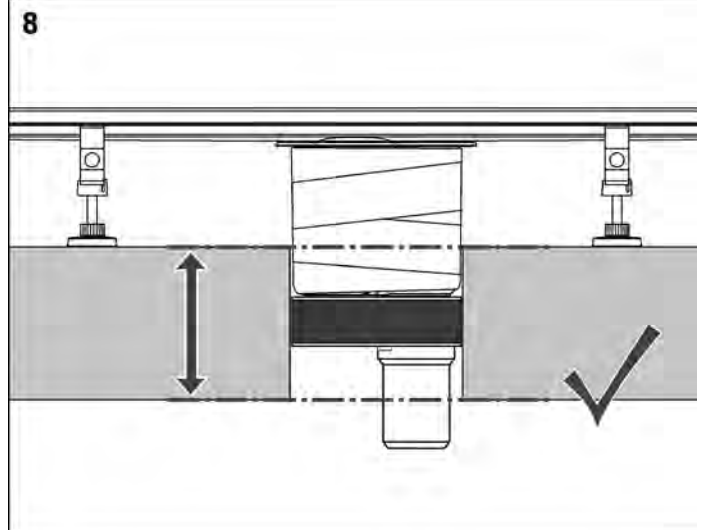
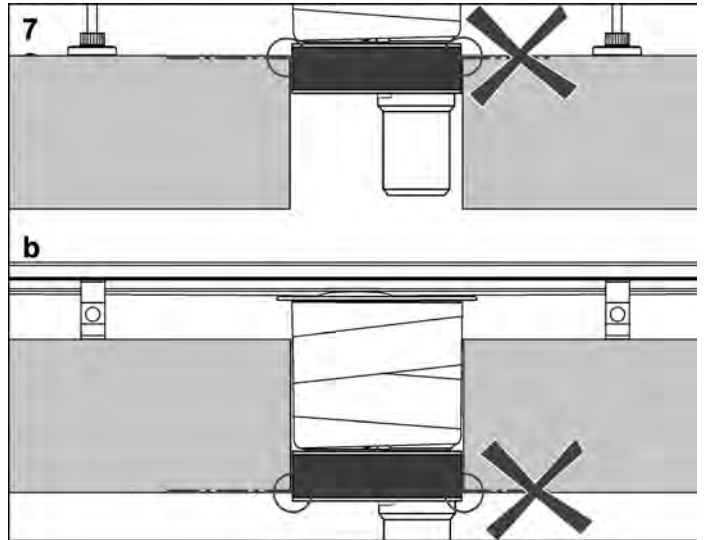

The fire protection sleeve must not protrude above or below the concrete floor.

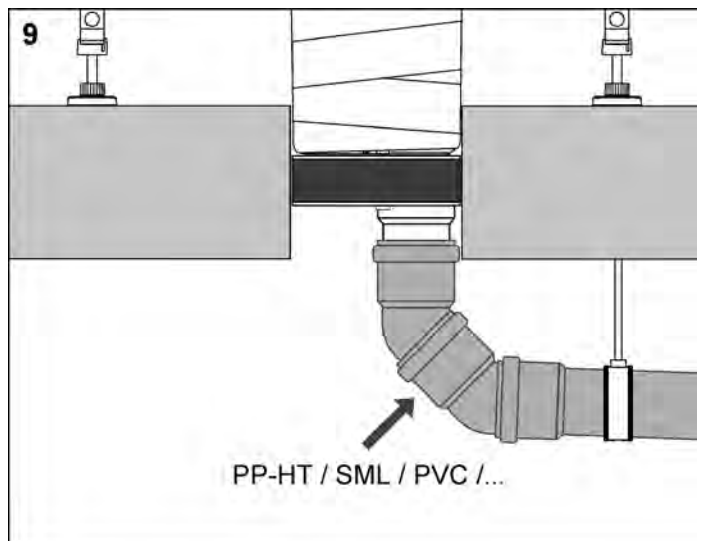

Transitions to other standard types of pipe and materials (made of PP-HT, SML, PVC, ...) can be connected to the first PP-HT pipe.

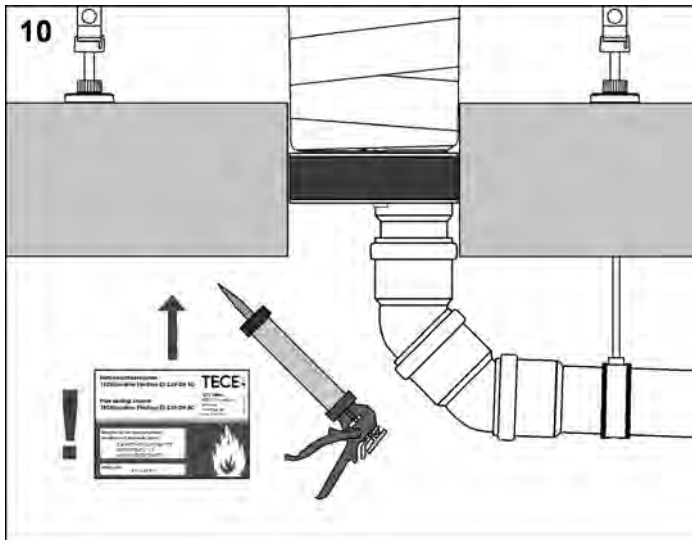

Write the details on the identification plate and secure it permanently - e.g. with silicone - in a clearly visible place next to the pipe closure system on the underside of the ceiling.



As well as the name of the fitter, the date of installation of the fire protection sleeve must be entered on the identification plate.

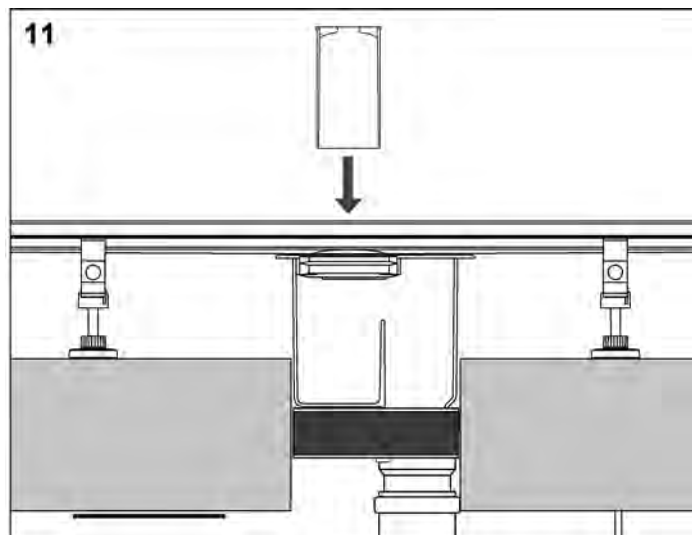

Insert the immersion pipe into the channel body.

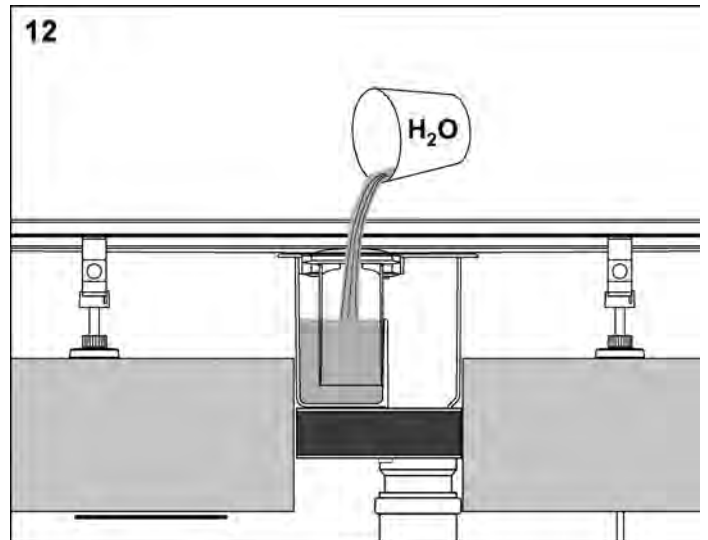

The water trap must be filled to prevent penetration of flames and fumes.

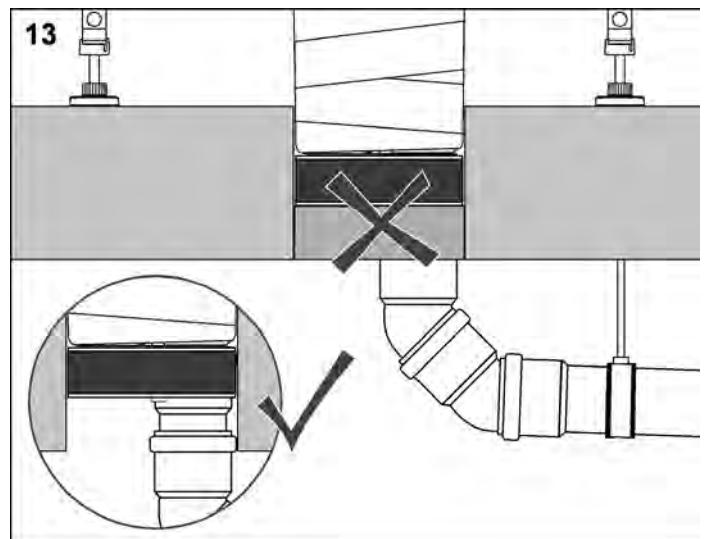

Important: The drilled hole below the fire protection sleeve must not be filled.

TECEdrainline – installation instructions

Installation instructions for sound-proofing mat

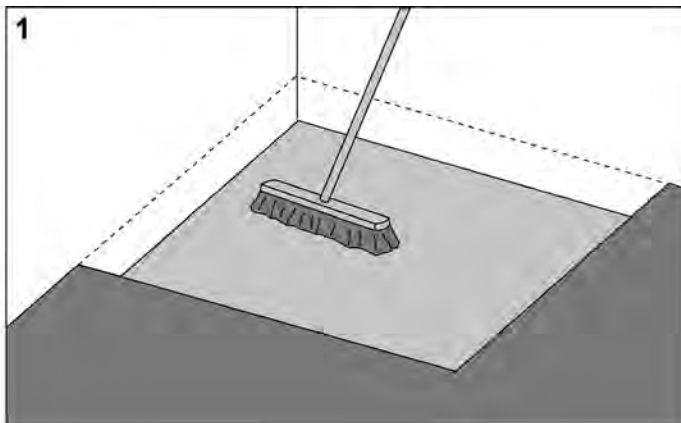

Clean the unfinished floor.

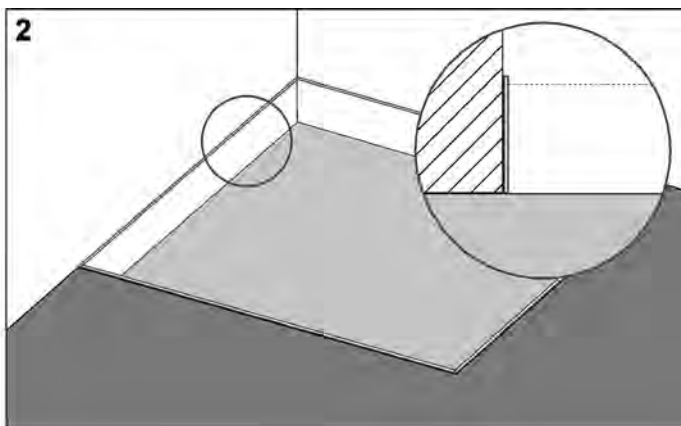

Apply edge insulation strips along the wall and to the existing screed surfaces.

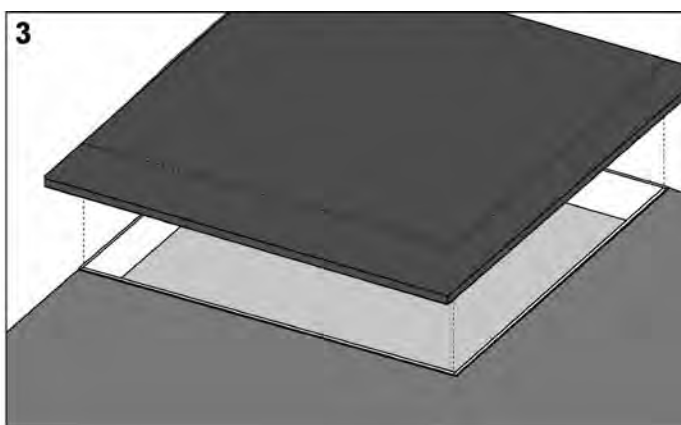

Transfer the required dimensions onto the "Drainbase" sound-proofing mat.

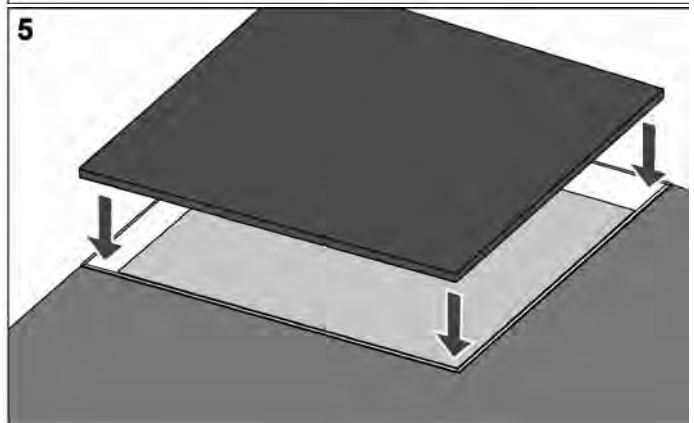

Cut the sound-proofing mat to size and lay it.

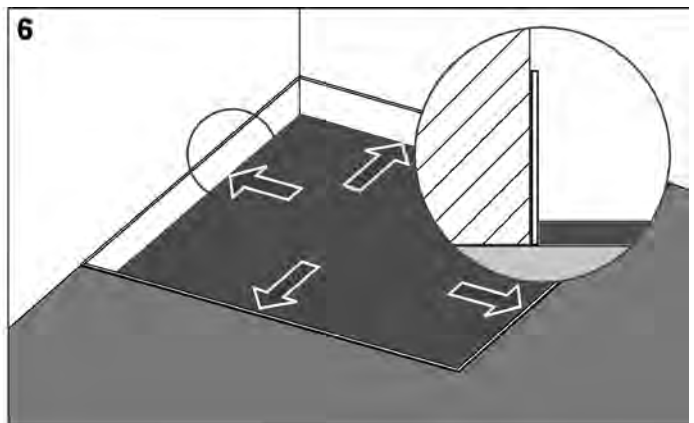

The sound-proofing mat should cover the whole floor surface.

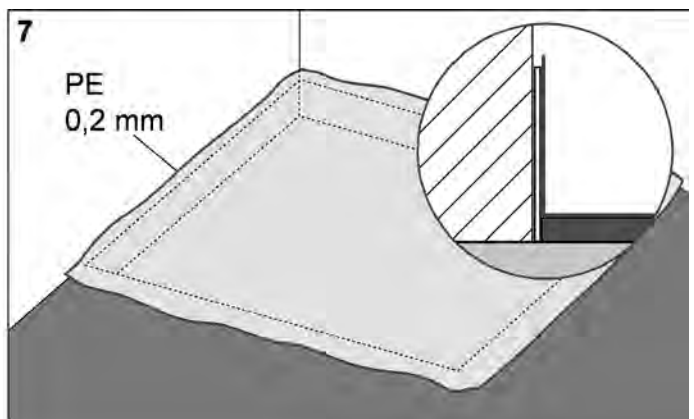

Lay out the PE film as shown.

Drainline feet installation instructions

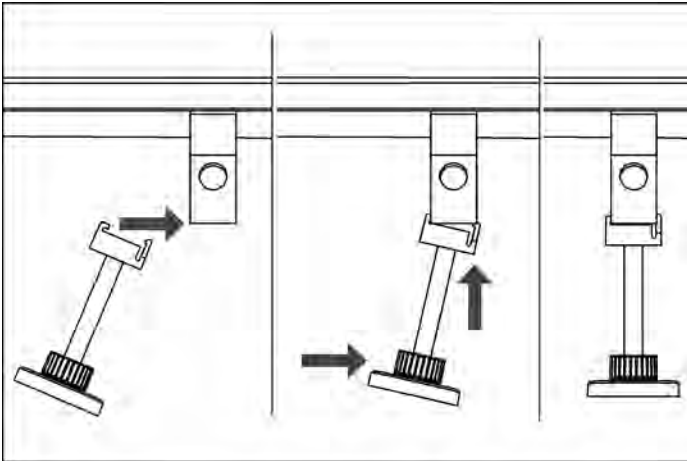

Hook the mounting feet in place, engage the clips and align them.

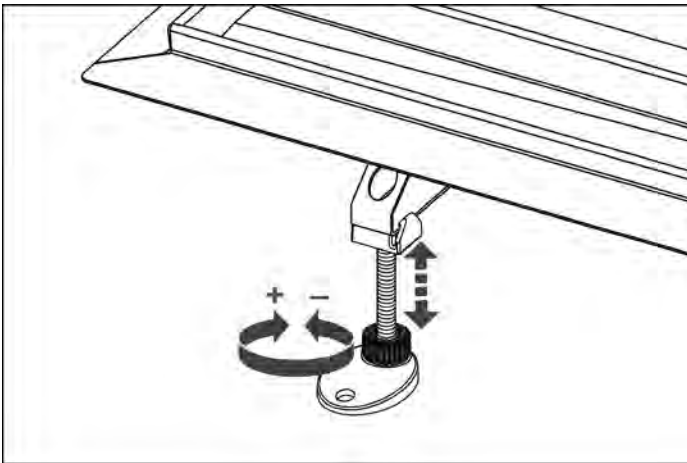

The height of the channel is set by turning the red adjusters on the feet. The alignment of the shower channel is checked using a spirit level.

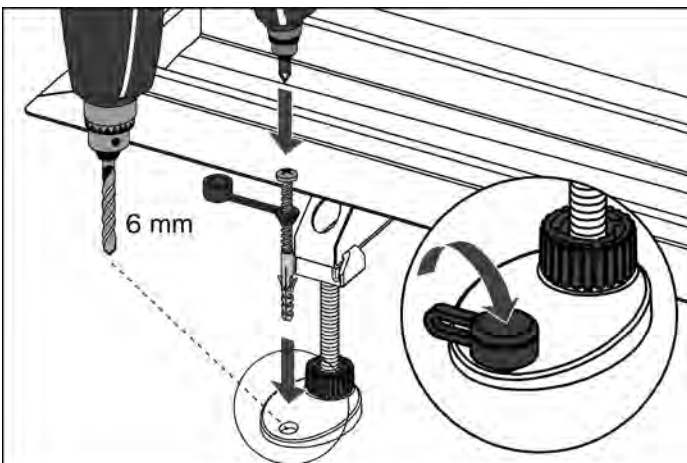

After it has been aligned, the feet can be secured in the floor through the Drainbase sound-proofing mat. A sound bridge is prevented by using the sound-absorbing elements (included in the scope of supply).

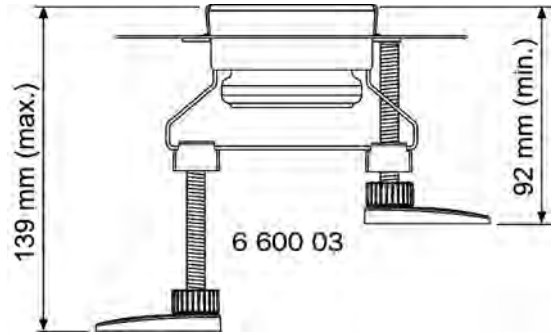

The adjustment range from the lower edge of the feet to the upper edge of the finished floor for item number 6 600 03 is 92–139 mm.

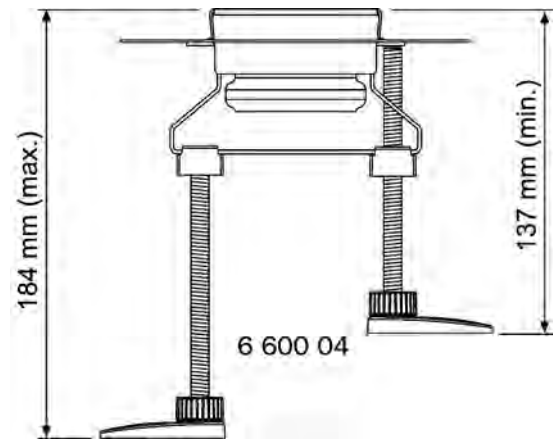

The adjustment range from the lower edge of the feet to the upper edge of the finished floor for item number 6 600 04 is 137–184 mm. When the "Max" outlet is installed, these longer mounting feet can be used.

Special channels

The TECEdrainline range is so comprehensive that straight and angled channels from 700 mm to 1500 mm are offered as standard. And if the standard channels do not meet the requirements, a special manufacture is possible – both for the "normal" shower channels and the shower channels for natural stone. Whether it is an exact length or two outlets for an extremely high drainage capacity – the special channels help in the realisation of special bathroom designs.

Please refer to the following pages for assistance in measuring and ordering.

TECEdrainline-custom-made channel – measurement sheet

Assistance in measuring and ordering TECEdrainline shower channels

Building project _____

TECE GmbH
Hollefeldstr. 57
DE-48282 Emsdetten

Fax +49 25 72/9 28-481 (West) Fax +49 25 72/9 28-482 (North) Fax +49 25 72/9 28-486 (South)

Property description

Quote number _____

Name _____

Street, No. _____

Town, Postcode _____

Delivery date _____ (about four to six weeks after technical approval by the customer)

TECE Field Services/processed by _____

Participants

Client _____

Contact _____

Street, Town _____

Telephone/Fax _____

Planner _____

Contact _____

Street, Town _____

Telephone/Fax _____

Contractor _____

Contact _____

Street, Town _____

Telephone/Fax _____

Wholesaler _____

Contact _____

Street, Town _____

Telephone/Fax _____

Order number _____

Please return and/or approve as quickly as possible !

Please complete the project, the quote number and the exact address of the contractor and/or wholesaler - we cannot process further without this information.

Building project _____

Notes: Standard values are used for all non-indicated values.
 The maximum channel length (L_1, L_4, L_5) is 1500 mm.

$L_1 =$ _____ mm

$L_2 =$ _____ mm*
 Centre drain

$L_3^{**} =$ _____ mm*

* max. distance between outer edge of channel and drain = 750 mm
 ** only for second drain

$L_4 =$ _____ mm*
 $L_5 =$ _____ mm*
 $L_6 =$ _____ mm*
 Centre drain
 $L_7 =$ _____ mm*
 Centre drain

* max. distance between outer edge of channel and drain = 750 mm

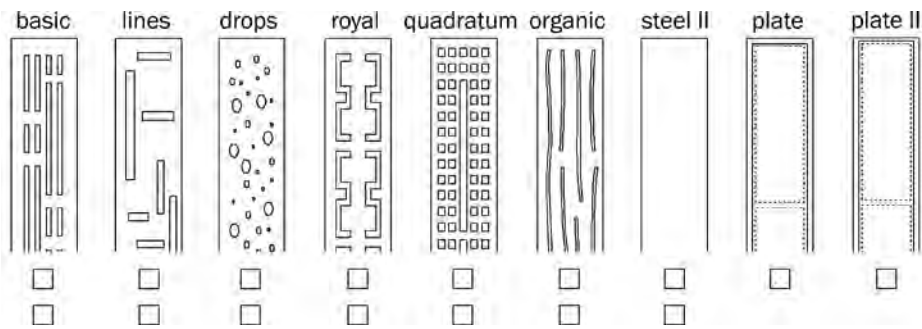
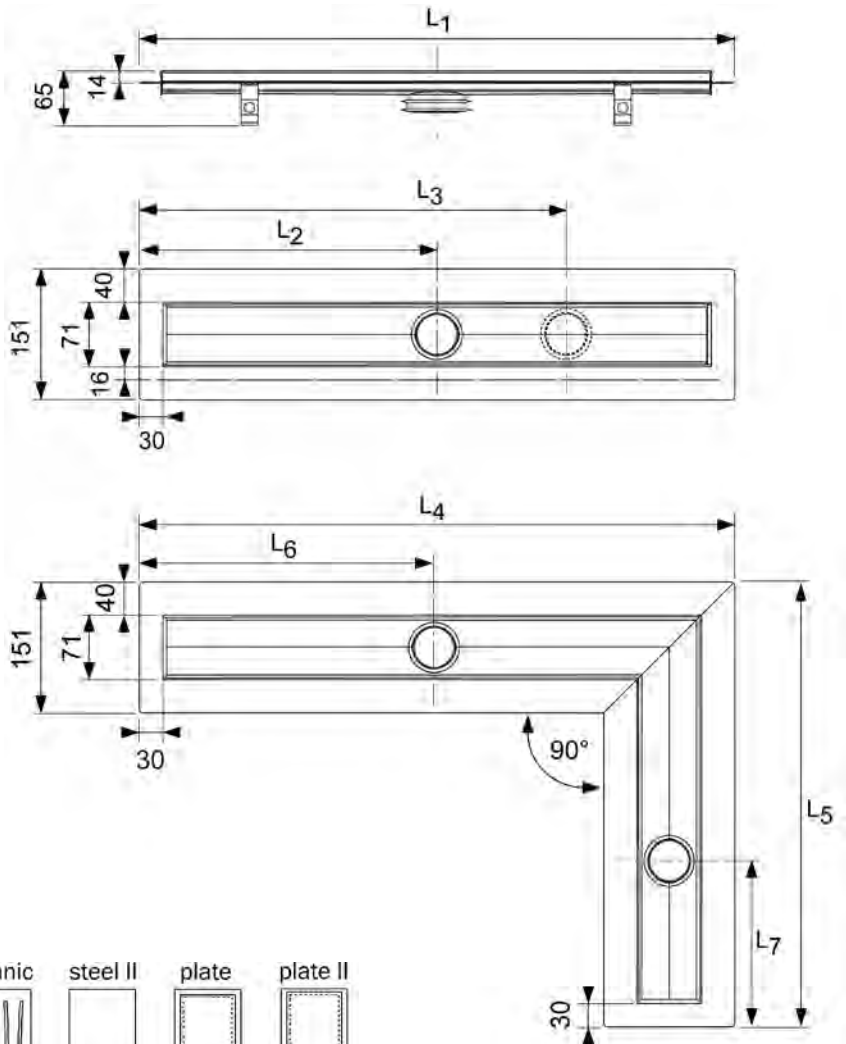

Please select drains and accessories (from current pricelist) and order separately.

Approval _____

Date, signature _____

TECEdrainline-custom-made channel for natural stone – measurement sheet

Assistance in measuring and ordering TECEdrainline shower channels for natural stone

Building project _____

TECE GmbH
Hollefeldstr. 57
DE-48282 Emsdetten

Fax 0 25 72/9 28-481 (West) Fax 0 25 72/9 28-482 (North) Fax 0 25 72/9 28-486 (South)

Property description

Quote number _____
Name _____
Street, No. _____
Town, postcode _____
Delivery date _____ (about four to six weeks after technical approval by customer)

TECE Field Services/processed by _____

Participants

Client _____
Contact _____
Street, Town _____
Telephone/Fax _____

Planner _____
Contact _____
Street, Town _____
Telephone/Fax _____

Contractor _____
Contact _____
Street, Town _____
Telephone/Fax _____

Wholesaler _____
Contact _____
Street, Town _____
Telephone/Fax _____

Order number _____

Please return and/or approve as quickly as possible !

Please complete the project, the quote number and the exact address of the contractor and/or wholesaler - we cannot process further without this information.

Building project _____

Note: Standard values will be used where no values are given.
The maximum channel length (L_1) is 1535 mm.

L_1 = _____ mm

L_2^* = _____ mm
 Central outlet

L_3^{**} = _____ mm

* max. distance between outlet and outside edge of channel = 750 mm

** only for 2. Outlet

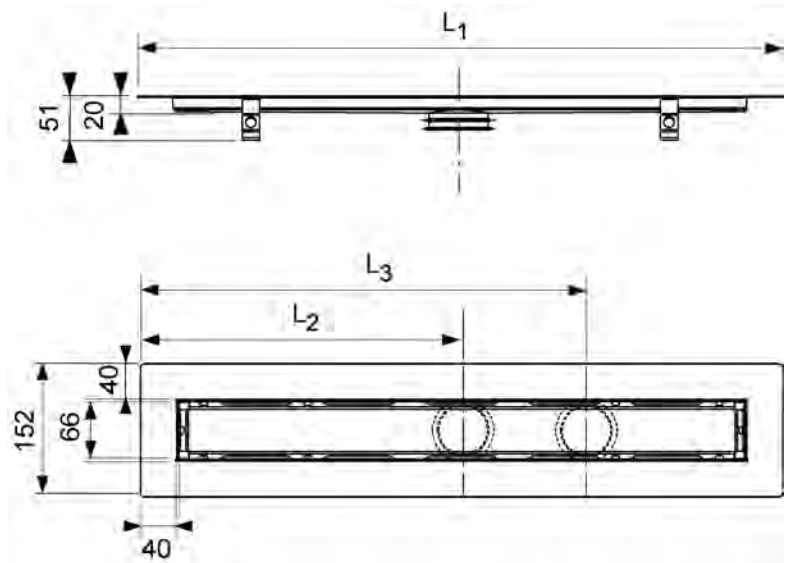

Note:
support included in the scope of supply.

Covering cut-out length x width: ($L_1 - 87$) x 68
width of surrounding drainage slot: 6 to 8 mm

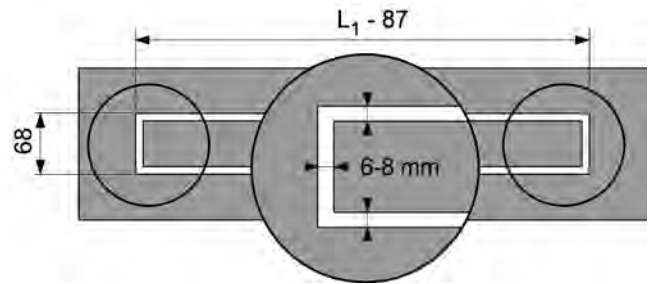

- | | |
|--|-------------------|
| <input type="checkbox"/> Outlet, super-flat DN 40, 0.48 l/s, min. height= 67 mm* | Item No. 6 500 04 |
| <input type="checkbox"/> Outlet, flat DN 50, 0.7 l/s, min. height = 95 mm* | Item No. 6 500 00 |
| <input type="checkbox"/> Outlet, standard DN 50, 0.8 l/s, min. height = 120 mm* | Item No. 6 500 01 |
| <input type="checkbox"/> Outlet, max DN 70, 1.2 l/s, min. height = 148 mm* | Item No. 6 500 02 |
| <input type="checkbox"/> Outlet, vertical DN 50, 1.3 l/s, min. height = 65 mm* | Item No. 6 500 03 |
| <input type="checkbox"/> Mounting foot, short (78–125 mm) | Item No. 6 600 03 |
| <input type="checkbox"/> Mounting foot, long (123–170 mm) | Item No. 6 600 04 |
| <input type="checkbox"/> Drainbase sound-proofing mat, 1.25 m x 1.25 m | Item No. 6 600 01 |
| <input type="checkbox"/> Drainbase sound-proofing mat, 1.25 m x 8.00 m | Item No. 6 600 02 |
| <input type="checkbox"/> Butyl adhesive tape, width 100 mm, length 10 m | Item No. 6 600 07 |
| <input type="checkbox"/> Hair trap | Item No. 6 600 05 |

* drainage capacity given for "central" outlet; min. height (without covering) to top edge of channel

Authorised _____

Date, signature _____

Standards

DIN 1986: Drainage systems for buildings and land

- Part 3: Rules for operation and servicing (2004)
- Part 4: Fields of application for waste water pipes and fittings made of various materials (2011)
- Part 30: maintenance (2012)

DIN 1986-100: Drainage systems for buildings and land/
regulations in connection with DIN EN 752 and
DIN EN 12056 (2008)

DIN 18024 parts 1 to 2: Barrier-free building/public
access to buildings and workplaces/planning fundamentals
(1996–1998)

DIN 18040 part 2: Barrier-free building - planning
fundamentals - dwellings (2011)

DIN 18195 parts 1 to 10: Water-proofing of buildings
(2009–2011)

DIN EN 12056, DIN 1986 and DIN EN 1610 note:
Building and land drainage (2000)

DIN EN 1253, Parts 1 to 3: Drains for buildings
(1999–2003)

DIN 4109 (1989): Soundproofing in high-rise building
construction, requirements and certificates, change A1
(2001)

VDI 4100: Soundproofing of dwellings – Criteria for
planning and evaluation (2007)

Building Regulations (MBO) (2002)

ZDB data sheet: Bonded sealants – Instructions for
processing wet-working bonded sealants with coverings
and claddings made of tiles and flags for indoor and
outdoor areas (2010)

PLASTER data sheet 5: Bathrooms and wet rooms in
wooden structures and drywall construction (2006)



TECEdrainpoint S

TECEdrainpoint S Technical Guidelines



Introduction	254
The most important product features:	254
Building drainage requirements	255
Damp-proofing	255
Drains	257
Strength	258
Accessible (barrier-free) bathroom design	258
TECEdrainpoint S – the advantages	259
Damp-proofing	259
Range and technical data	261
Drain sets	261
Modular system	263
Drains	264
Extension pieces	265
Accessories	267
Assembly instructions	270
Installation of drain with thin-bed sealing	270
Installation of drain with clamped flange sealing	273
Installation of drain without flange	277
Standards	278

TECEdrainpoint S – introduction

Introduction

The new standard for point drainage:
Innovation with a system – resistant, robust, universal.
For the first time, TECE is offering a completely newly developed and innovative drain range made of plastic.

The most important product features:

The universal flange

Just one flange for all applications – as a result, both liquid and strip composite seals and clamped flange connections are possible.

The advantage: No longer any distinction in planning and ordering.

Direct thin-bed sealing without extension piece

With the universal flange of the new TECEdrainpoint S drains, DN 50 – and now also DN 70 and DN 100 – drains can be installed directly in the thin-bed seal, without an additional raising element.

Universal use

There is now just one size for all extension pieces, raising elements, odour traps and grate frames, regardless of whether you use DN 50 extra-flat or DN 100 vertical. Grates with dimensions 100 x 100 mm and 150 x 150 mm also fit to all drains.

Always the right drain

You will always find the right drain in the TECEdrainpoint S range, whether only a low assembly height is available or you require a high drainage capacity. The TECEdrainpoint S DN 70 with 98 mm assembly height is currently the flattest DN 70 floor drain on the market, for example.

Innovation

The removable, two-stage membrane odour trap reliably prevents the escape of unpleasant odours and if necessary can work as a foam barrier

Cleaning and maintenance

All odour traps can be removed at any time, even after assembly.



Building drainage requirements

Damp-proofing

If the subsurface is damp-proofed before the tiles are laid, water cannot penetrate into the subsurface. Damp-proofing is particularly important in the wall and floor areas that are directly subject to water spray, i.e. in the shower or over the edge of the tub. A water-tight coating here provides additional protection against dampness that can seep through the joints.

Damp-proofing according to ZDB (Zentralverband Deutsches Baugewerbe) information sheet:

According to the building regulations of the German federal states, buildings are to be designed so that "risks or unreasonable strain do not arise through water, dampness [...] or other chemical, physical or biological influences."

Parts of a building affected by damp in building complexes, such as bathrooms, shower rooms, on terraces, balconies, commercial kitchens and so on, must therefore be protected against moisture penetration.

Rooms or parts of a building exposed to dampness are generally clad or given a covering made of tiles and panels. This cladding or ceramic covering is damp-resistant and water-repellent, but depending on the type of jointing in areas directly subject to dampness are so water-permeable that they usually require additional damp-proofing.

The ZDB information sheet describes bonded damp-proofing with tiles and panels in indoor and outdoor areas taking account of defined dampness intensities and subsurfaces.

The thin-bed seals (bonded damp-proofing) shown have proven their worth effectively in practical applications. As a rule, the information sheet is an important basis for correct planning and application technology. In addition, the specific installation information in the TECE installation instructions should be observed.

When structures are designed in accordance with this information, the covering and cladding with tiles and panels in a thin bed provide a protective layer. In the case of floor structures with insulation layers, this damp-proofing is placed directly on top of the load distribution layer (screed). The covering can be laid in the thin bed on top of this, so thicker protective layers are not required.

The advantages of thin-bed sealing:

- No moisture from hygienically and/or chemically critical liquids can penetrate the subsurface.
- Low-cost alternative to the damp-proofing defined in DIN 18195.

TECEdrainpoint S – building drainage requirements

Dampness exposure classes according to ZDB

Exposure class	Exposure	Application areas	Damp-proofing material
A	High exposure through non-pressing water in indoor areas	Directly and indirectly exposed areas in rooms in which process and cleaning water is used very frequently or for very long periods, e.g.: Corridors in swimming pools and shower facilities (public or private)	- Polymer dispersion, for walls only - Plastic-mortar combination - Reaction resins
B	High exposure through water constantly pressing from inside in indoor and outdoor areas	Surfaces of containers exposed to pressurized water, e.g.: Public and private swimming pools in indoor and outdoor areas	- Plastic-mortar combination - Reaction resins
C	High exposure through non-pressing water with additional chemical exposure in indoor areas	Directly and indirectly exposed areas in rooms in which process and cleaning water is used very frequently or for very long periods, also with limited exposures of the damp-proofing to chemicals, e.g.: In commercial kitchens and laundries	- Reaction resins

Dampness exposure classes in areas regulated by the building inspectorate (high exposure)

Exposure class	Exposure	Application areas	Damp-proofing material
A0	Moderate exposure through non-pressing water in indoor areas	Directly and indirectly exposed areas in rooms in which process and cleaning water is not used very frequently, e.g.: In domestic bathrooms, hotel bathrooms, floor areas with drains in these application areas	- Polymer dispersion - Plastic-mortar combination - Reaction resins In the case of damp-insensitive subsurfaces in moderately exposed areas, damp-proofing on wall areas may not be essential, depending on the application case. The connection to other exposed areas must be created using sealing tape.
B0	Moderate exposure through non-pressing water in outdoor areas	Directly and indirectly exposed outdoor areas with non-pressing water, e.g.: on balconies and terraces (not above rooms in use)	- Plastic-mortar combination - Reaction resins

Dampness exposure classes in areas not regulated by the building inspectorate (moderate exposure)

Application in areas regulated by the building inspectorate

For bonded damp-proofing (system consisting of damp-proofing material and thin-bed mortar), a general building inspectorate test certificate (abP) from a recognized testing centre is essential.

The abP contains the following mandatory stipulations:

- The system usage area
- Minimum dry layer thickness of the damp-proofing material
- Product name of the thin-bed mortar or adhesive permitted for use

In addition, the damp-proofing material must have the mark of conformity (Ü mark).

Instead of an abP for exposure class A, verification can alternatively be provided by means of a European technical approval (EtA) in accordance with EtAg 022, Part 1 and the stipulations of Part 2 of the list of technical construction regulations (test certification for exposure class A).

For exposure classes B and C, verification can alternatively be provided by means of a European technical approval (EtA) without guidelines that cover the relevant usage areas. The stipulations within the EtA are then binding.

Damp-proofing systems traded on the basis of an EtA must bear the CE mark. The thin-bed mortar or adhesive specified in the abP or EtA must be tested in accordance with DIN EN 12004 and must bear the CE mark.

Use in areas not regulated by the building inspectorate

An abP is not granted for these areas. In exposure classes A0 and B0, products with an abP in accordance with the testing principles for bonded damp-proofing should be used to obtain an abP

Instead of an abP for dampness exposure class A, verification can alternatively be provided by means of a European technical approval (EtA) in accordance with EtAg 022, Part 1 and the stipulations of Part 2 of the list of technical construction regulations (test certification for exposure class A).

Damp-proofing systems that are traded on the basis of an EtA must bear the CE mark. The thin-bed mortar or adhesive specified in the abP or EtA must also be tested in accordance with DIN EN 12004 in the non-regulated area, and must bear the CE mark.

Damp-proofing materials

Possible damp-proofing materials are polymer dispersions for classes A and A0; plastic-mortar combinations can be used in classes A, A0, B and B0. Reaction resins are suitable for all classes, but are in principle oversized in the regulated area. Building inspectorate approval is not required for the non-regulated area.

However, the information sheet requires a proof of quality, which is provided in accordance with the same testing principles as those mandatory in the area regulated by the building inspectorate.

Which set of rules regulates what?

	Construction regulation list	ZDB information sheet
Damp-proofing materials and adhesives	X	X
Minimum layer thickness	X	X
Subsurfaces		X
Sealing of joints		X
Sealing of penetrations and built-in parts		X

Floors

Only damp-resistant materials, such as concrete in accordance with DIN 1045, cement screed in accordance with DIN 18560 (heated and unheated), unheated cast asphalt screeds in accordance with DIN 18560, and - in indoor areas - composite elements made of expanded or extruded polystyrene with a mortar layer and webbing reinforcement are permitted as subsurfaces.

The subsurfaces must be sufficiently dry.

The residual dampness of cement screeds must not exceed 2.0 CM-%.

Walls

Concrete according to DIN 1045, suitable concrete or lime-cement plasters according to DIN EN 998-1 or DIN V 18550, fully pointed masonry, porous concrete elements, lightweight concrete hollow boards and hard foam core boards with mortar coating are suitable as subsurfaces.

Drains

The main design requirements relating to floor drains, such as drainage capacity, are described in DIN EN 1253. The table shows the minimum drain values for floor and roof drains (not for syphonic drainage). The minimum value of a drain with odour trap with lateral connections can be assumed to be 0.4 l/s for drainage of water from a shower head.

The drainage values for drains with one or more inlets can be found in DIN EN 1253-1 section 8.11.2.

Nominal value of drain connector		Floor drains	
DN / OD	DN / ID	Drainage values	Water height
32	30	0.4 l/s	20 mm
40	40	0.6 l/s	20 mm
50	50	0.8 l/s	20 mm
75	70	0.8 l/s	20 mm
110	100	1.4 l/s	20 mm
125	125	2.8 l/s	20 mm
160	150	4.0 l/s	20 mm

Drainage capacity (inflow via the grate) – minimum drainage values for drains

TECEDrainpoint S – building drainage requirements

Strength

Drains, extensions and grates must be designed so that they can withstand the expected loads (e.g. including vehicular traffic). These classifications for installation within buildings are described in DIN EN 1253-1.

Load class	Max. permitted load	Area of application/location of use
H 1.5	< 150 kg	For unused flat rooms such as roofs with bitumen gravel, gravel roofs and similar
K 3	< 300 kg	For areas without vehicular traffic, such as bathrooms in residential buildings, hotels, old people's homes, schools, swimming pools, public wash rooms and showers, balconies, loggias, terraces and green roofs.
L 15	< 1.5 t	For areas with light vehicular traffic, excluding fork lift trucks, in commercially used rooms.
M 125	< 12.5 t	For areas with vehicular traffic, such as car parks, factories and workshops.

Strength according to DIN EN 1253-1

The planner is responsible for selecting the suitable class. In cases of doubt, the higher load class should be selected.

Accessible (barrier-free) bathroom design

Demographic change is increasing the demand for barrier-free homes. Disability, accident or old age – there are numerous reasons why people become restricted in their movements, or need to use a wheelchair. For them, it is important that not only public buildings but also - in particular - their own homes are designed so that they can move around freely. "Accessibility" and "barrier-free" are the terms used to describe this in the industry. Sufficiently wide doors, no door steps, no stairs, and a floor-level shower are the requirements for achieving this. TECEDrainline makes a life without barriers possible in the shower area. The floor-level shower channel makes it easier to get into the shower area.

The specifications of DIN 18040-2 must be adhered to when planning a barrier-free sanitary facility.

DIN 18040-2:

DIN 18040-2 differentiates between two types of requirements for residences. Firstly, barrier-free residences, and secondly, barrier-free residences that can be used without restriction in a wheelchair. This second category is indicated by a large bold **R**.

General information:

- In residences with several sanitary facilities, at least one must be barrier-free.
- Fittings should be single-lever or non-contact. In the case of non-contact fittings, a temperature limiter must be incorporated. Here, the water outlet temperature must be limited to 45°C.

Areas for manoeuvre:

An area for manoeuvre must be incorporated in front of each sanitary object such as toilet bowl, washstand, bath tub and shower. A minimum area of 1.20 m x 1.20 m is sufficient here (**R**: 1.50 m x 1.50 m). Areas for manoeuvre may overlap.

Showers:

Shower areas must be designed to be barrier-free, meaning they can also be used with a wheeled walker or wheelchair.

This is achieved through

- A shower area at the same level as the adjacent floor area of the room and a drop of max. 2 cm; any transitions should where possible be designed as sloping areas;
- Skid-resistant floor coverings in the shower area (corresponding to GUV-I 8527 at least valuation group B);
- **(R)** Option of subsequently installing a fold-out shower seat, with a seat height of 46 cm to 48 cm;
- **(R)** Option of subsequently installing a fold-out shower seat, with a seat height of 46 cm to 48 cm;
- **(R)** On both sides of the fold-out shower seat the option of subsequently installing fold-up support arms, the upper edge of which is 28 cm above the seat height.

The area of the shower can be included as part of the areas for manoeuvre of the bathroom if

- the transition to the shower area is at the same floor level;
- the incline needed for drainage is max. 2 %.

TECEdrainpoint S – the advantages

Universal flange

The TECEdrainpoint S plastic drains are fitted with a universal flange. The flange is suitable for liquid/strip composite seals and clamped flange connections.

As a result, the range is simple and streamlined. The right drain is always to hand, regardless of your installation situation or damp-proofing method.

Hygiene

The odour trap of the TECEdrainpoint S drains can be removed at any time. It consists of an inlet part and a beaker and can therefore be taken apart and cleaned. Any dirt that has entered the drain is therefore caught in the odour trap beaker and can be easily removed.

Membrane odour trap

Another innovation is the two-stage membrane odour trap for retrofitting. This has two functions: Firstly, it has a membrane that opens as soon as water runs into the drain, and closes again afterwards to retain any odours. Secondly, it has a low barrier water height and is therefore doubly reliable. The membrane odour trap can also be used as a foam barrier, e.g. in rooms with multiple showers, or as a vermin barrier in terrace drains without a beaker.

Damp-proofing

With TECEdrainpoint S plastic drains, two damp-proofing methods are possible (see also figure below):

- (A) Thin-bed sealing or strip sealing using a sealing sleeve (PE) or
- (B) Connection of e.g. bitumen strips with cut-to-size sealing foil (EPDM) as a clamped flange connection

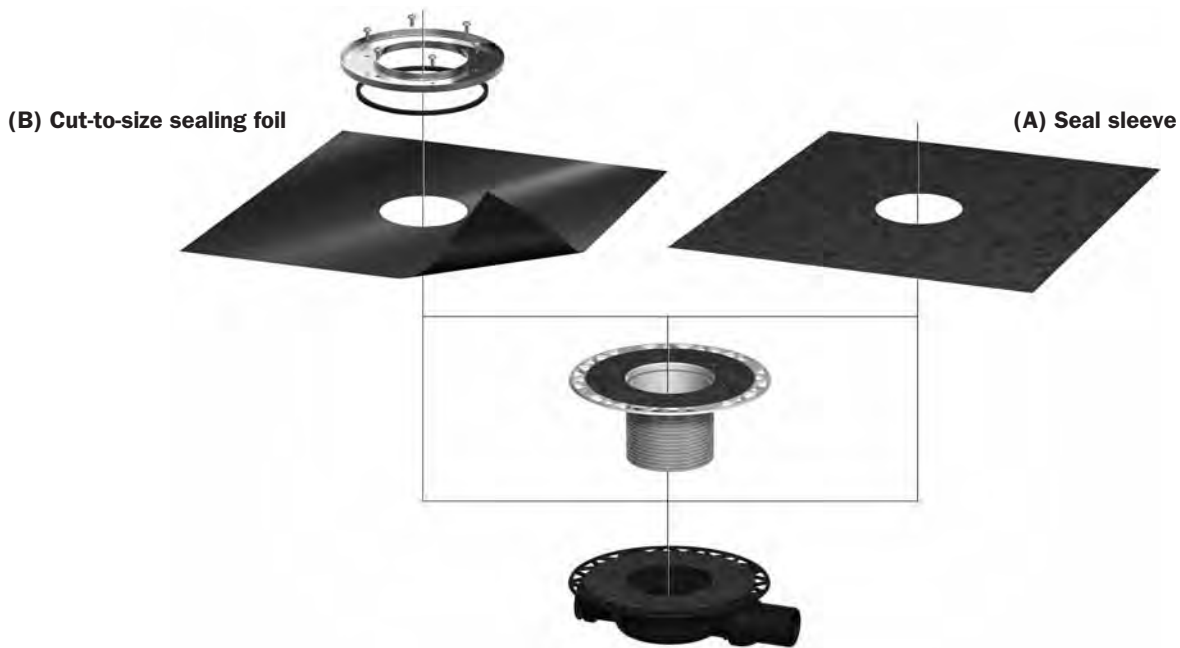

TECEdrainpoint S – installation examples

Installation examples

The TECEdrainpoint plastic drains bring together multiple usage scenarios in a single drain system. They can be used as bathroom, floor, terrace or cellar drains.

Appropriate drain bodies, drain tops and accessories are available for each of these scenarios.

Installation in the bathroom

When drains are installed in bathrooms and shower areas, they are usually set in the screed after they have been connected to the waste water. They are then sealed in with tiles and slabs

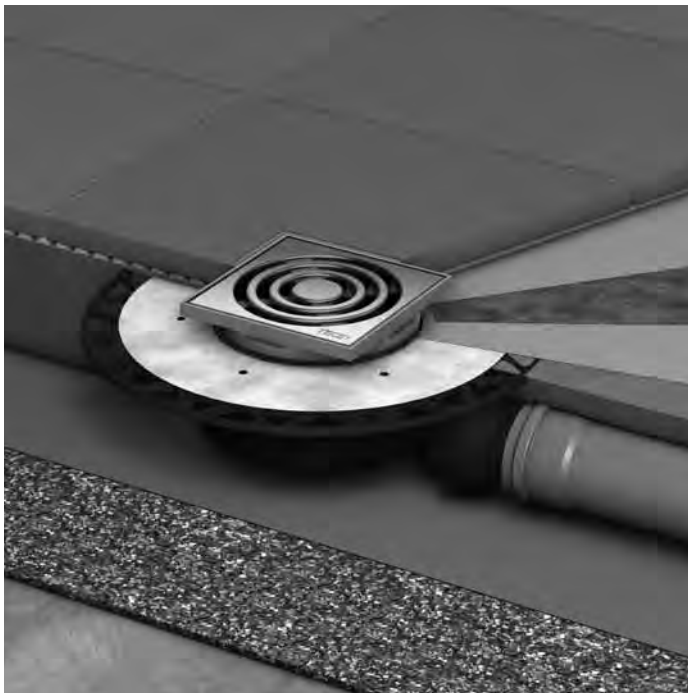

Installation in the bathroom/shower area with bonded damp-proofing

Installation on terraces and balconies

When installed on a terrace or balcony, a drain body without an odour trap must be used. This ensures that no water remains in the drain, which could otherwise cause frost damage.

Installation in the cellar

The TECEdrainpoint S drains are also suitable for installation in the cellar or other rooms in which bonded damp-proofing is not required.

In these cases, the drain can be incorporated in the building waterproofing – in accordance with DIN 18195. This is usually achieved with a clamped flange connection. If there are no damp-proofing requirements, it can also be set directly in the floor screed, without sealing.



Installation in the cellar area, damp-proofing using clamped flange sealing

Range and technical data

The TECEdrainpoint S plastic drain range has a modular structure and consists of four complete drains, a drain modular system and various accessories

Drain sets

The four drain sets each consist of a drain base body, drain top and cover. All drain sets have a drain socket in the nominal width DN 50 drains. There are three horizontal versions (2 x extra-flat and 1 x standard) and one horizontal version.



The four TECEdrainpoint S drain sets

Drain set S 50

Floor drain set horizontal extra-flat DN 50

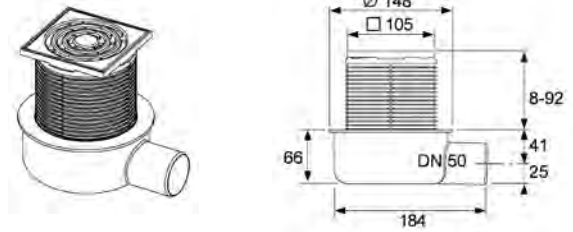

Consisting of:

- Drain body DN 50 horizontal extra-flat made of plastic (PP)
- With retaining edge
- With removable odour trap
- Drainage capacity 0.6 l/s
- Reduced sealing water height = 30 mm
- Drain top with grate frame made of plastic (ABS) and O-ring seal
- TECEdrainpoint design grate made of drawn stainless steel, material 1.4301 (304), dimension 100 x 100 mm polished surface, load class K3 (load of up to 300 kg)

Order number 360 10 50

Drain set S 110

Drain set horizontal extra-flat DN 50 with universal flange, tested to DIN EN 1253

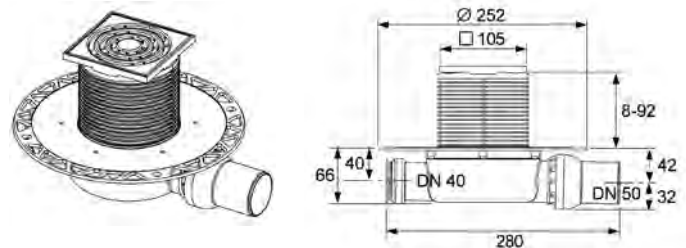

Consisting of:

- Drain body DN 50 horizontal extra-flat made of plastic (PP)
- With universal flange for thin-bed, strip seals or clamped flange connections
- With ball joint
- With lateral inflow DN 40 incl. closure plug
- With removable odour trap
- Drainage capacity 0.8 l/s
- Reduced sealing water height = 30 mm
- Drain top with grate frame made of plastic (ABS) and O-ring seal
- TECEdrainpoint design grate made of drawn stainless steel, material 1.4301 (304), dimension 100 x 100 mm polished surface, load class K3 (load of up to 300 kg)

Order number 360 11 00

TECEdrainpoint S – range and technical data

Drain set S 120

Drain set horizontal extra-flat DN 50 with universal flange, tested to DIN EN 1253

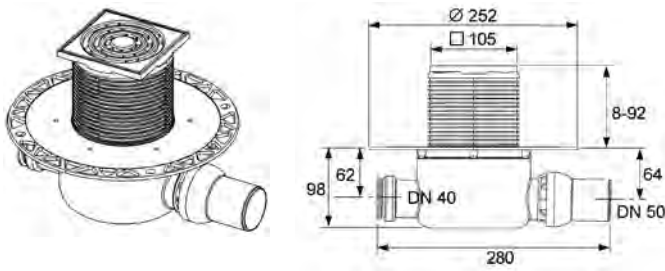

Consisting of:

- Drain body DN 50 horizontal extra-flat made of plastic (PP)
- With universal flange for thin-bed, strip seals or clamped flange connections
- With ball joint
- With lateral inflow DN 40 incl. closure plug
- With removable odour trap
- Drainage capacity 0.8 l/s
- Reduced sealing water height = 30 mm
- Drain top with grate frame made of plastic (ABS) and O-ring seal
- TECEdrainpoint design grate made of drawn stainless steel, material 1.4301 (304), dimension 100 x 100 mm polished surface, load class K3 (load of up to 300 kg)

Order number 360 12 00

Drain set S 130

Drain set vertical DN 50 with universal flange, tested to DIN EN 1253

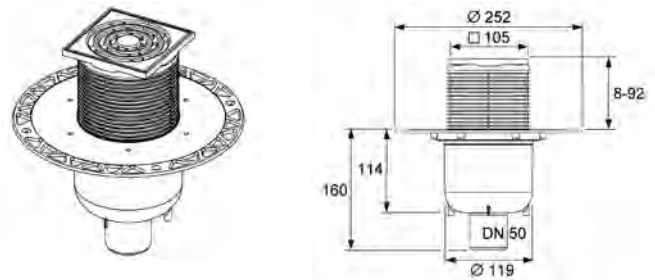

Consisting of:

- Drain body DN 50 vertical made of plastic (PP)
- With universal flange for thin-bed, strip seals or clamped flange connections
- With removable odour trap
- Drainage capacity 1.5 l/s
- Sealing water height = 50 mm in keeping with DIN EN 1253
- Drain top with grate frame made of plastic (ABS) and O-ring seal
- TECEdrainpoint design grate made of drawn stainless steel, material 1.4301 (304), dimension 100 x 100 mm polished surface, load class K3 (load of up to 300 kg)

Order number 360 13 00

Modular system

With the TECEdrainpoint modular system, a complete drain can always be created from the three basic components – drain body, drain top and cover:

- 8 drain bodies from DN 50 horizontal extra-flat to DN 100 vertical
- Drain tops with grate frame of plastic or stainless steel, □ 100 or 150 mm
- Design grates made of stainless steel 100 x 100 mm or 142 x 142 mm, "loose" or screw-down

The free combination of parts reduces warehousing costs and simplifies ordering.

Alternatively, there are the four complete drain sets for the most common drain combinations.

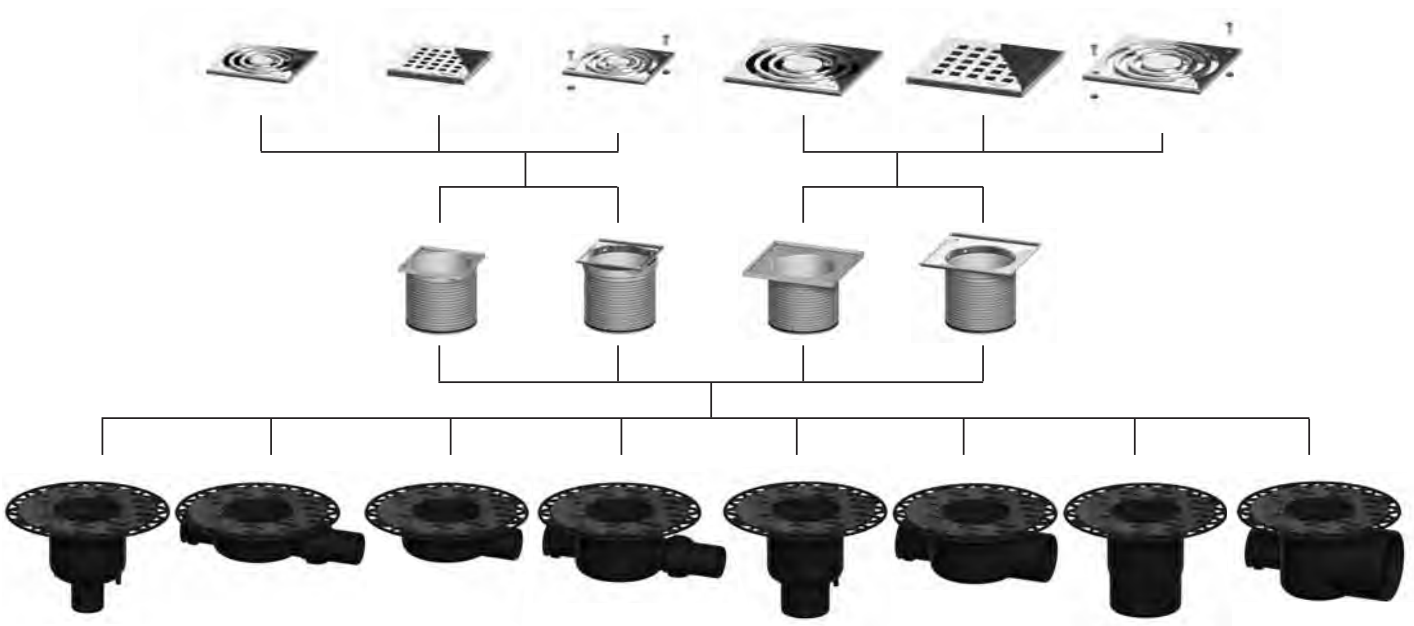

TECEdrainpoint S - modular system with method

The following components are optionally available:

- Raising element with universal flange
- Extension



TECEdrainpoint S – range and technical data

Drains

Drain DN 50 extra-flat

Floor drain DN 50 horizontal extra-flat made of plastic (PP)

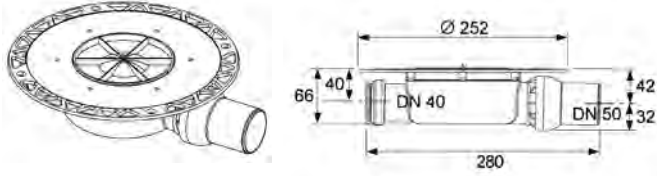

- With universal flange for thin-bed, strip seals or clamped flange connections
 - With ball joint
 - With lateral inflow DN 40 incl. closure plug
 - With removable odour trap
 - Drainage capacity 0.8 l/s
 - Reduced sealing water height = 30 mm
- Order number 360 14 00

Drain DN 50 terrace extra-flat

Floor drain as terrace or balcony drain DN 50 horizontal extra-flat made of plastic (PP)

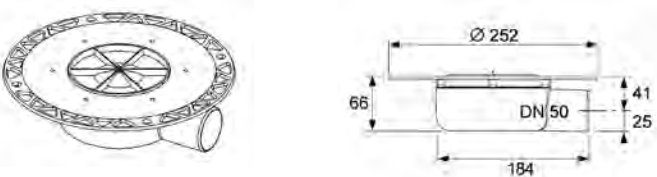

- With universal flange for thin-bed, strip seals or clamped flange connections
 - Without odour trap
 - Drainage capacity 0.6 l/s
- Order number 360 14 01

Drain DN 50 standard

Drain DN 50 horizontal standard made of plastic (PP), tested to DIN EN 1253

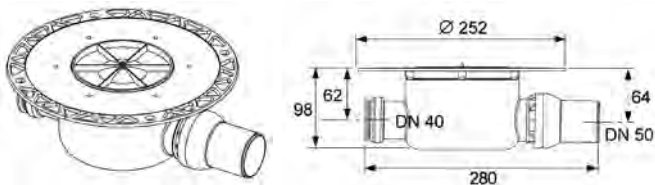

- With universal flange for thin-bed, strip seals or clamped flange connections
 - With ball joint
 - With lateral inflow DN 40 incl. closure plug
 - With removable odour trap
 - Drainage capacity 1.1 l/s
 - Sealing water height = 50 mm in keeping with DIN EN 1253
- Order number 360 15 00

Drain DN 50 vertical

Floor drain DN 50 vertical made of plastic (PP), tested to DIN EN 1253

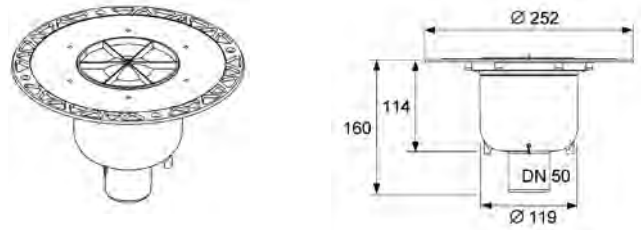

- With universal flange for thin-bed, strip seals or clamped flange connections
 - With removable odour trap
 - Drainage capacity 1.5 l/s
 - Sealing water height = 50 mm in keeping with DIN EN 1253
- Order number 360 16 00

DN 70 drain

Floor drain DN 70 horizontal made of plastic (PP), tested to DIN EN 1253

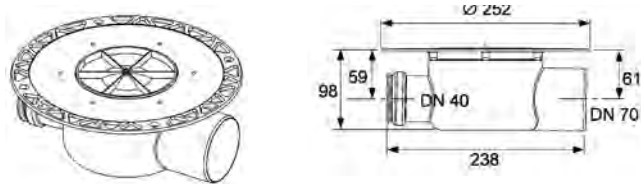

- With universal flange for thin-bed, strip seals or clamped flange connections
 - With lateral inflow DN 50 incl. closure plug
 - With removable odour trap
 - Drainage capacity 1.4 l/s
 - Sealing water height = 50 mm in keeping with DIN EN 1253
- Order number 360 35 00

Drain DN 70 vertical

Floor drain DN 70 vertical made of plastic (PP), tested to DIN EN 1253

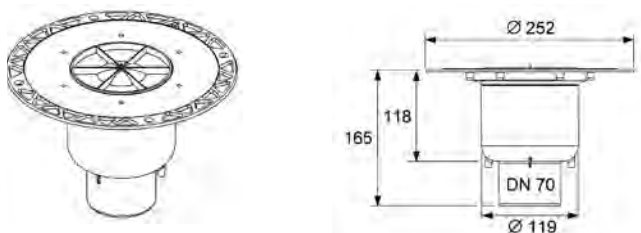

- With universal flange for thin-bed, strip seals or clamped flange connections
 - With removable odour trap
 - Drainage capacity 1.8 l/s
 - Sealing water height = 50 mm in keeping with DIN EN 1253
- Order number 360 36 00

DN 100 drain

Floor drain DN 100 horizontal made of plastic (PP), tested to DIN EN 1253

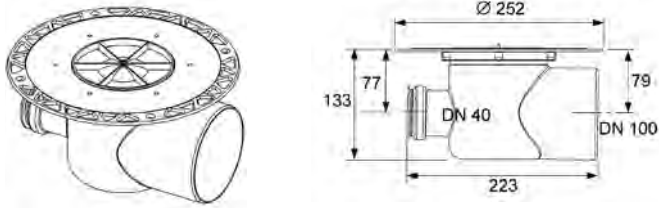

- With universal flange for thin-bed, strip seals or clamped flange connections
- With lateral inflow DN 50 incl. closure plug
- With removable odour trap
- Drainage capacity 1.8 l/s
- Sealing water height = 50 mm in keeping with DIN EN 1253

Order number 360 75 00

Drain DN 100 vertical

Floor drain DN 100 vertical made of plastic (PP), tested to DIN EN 1253

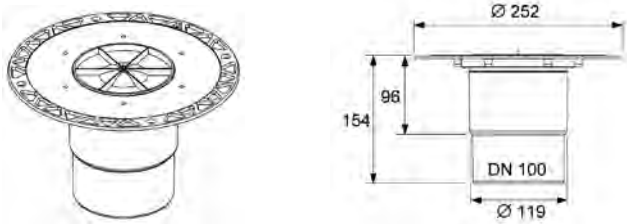

- With universal flange for thin-bed, strip seals or clamped flange connections
- With removable odour trap
- Drainage capacity 2.0 l/s
- Sealing water height = 50 mm in keeping with DIN EN 1253

Order number 360 76 00

Extension pieces

TECEDrainpoint grate frame plastic, 100 mm, incl. design grate

Set consisting of drain top with grate frame (plastic) and TECEDrainpoint design grate 100 x 100 mm

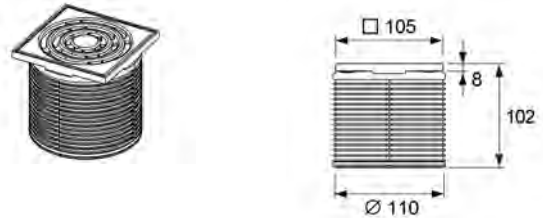

- Drain top with grate frame made of plastic (ABS)
 - O-ring seal
 - Outer diameter = 110 mm
 - Height adjustment = 8.5 to 91.5 mm
 - TECEDrainpoint design grate made of drawn stainless steel, material 1.4301 (304), dimension 100 x 100 mm polished surface, load class K3 (load up to 300 kg)
- Order number 366 00 01

TECEDrainpoint grate frame stainless steel, 100 mm, incl. design grate

Set consisting of drain top with grate frame (stainless steel) and TECEDrainpoint design grate 100 x 100 mm

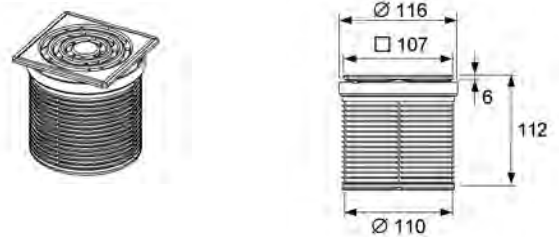

- Drain top made of plastic (ABS)
 - O-ring seal
 - Outer diameter = 110 mm
 - Height adjustment = 7 to 102 mm
 - Grate frame made of drawn stainless steel
 - TECEDrainpoint design grate made of drawn stainless steel, material 1.4301 (304), dimension 100 x 100 mm polished surface, load class K3 (load up to 300 kg)
- Order number 366 00 02

TECEDrainpoint S – range and technical data

TECEDrainpoint grate frame plastic, 150 mm, incl. design grate

Set consisting of drain top with grate frame (plastic) and TECEDrainpoint design grate 142 x 142 mm

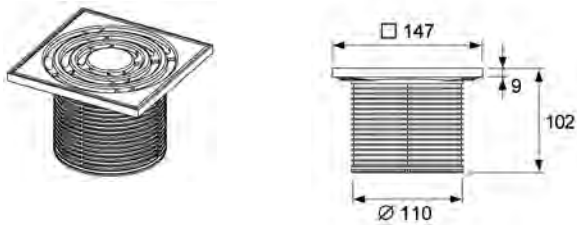

- Drain top with grate frame made of plastic (ABS)
 - O-ring seal
 - Outer diameter = 110 mm
 - Height adjustment = 12 to 91.5 mm
 - TECEDrainpoint design grate made of drawn stainless steel, material 1.4301 (304), dimension 142 x 142 mm polished surface, load class K3 (load up to 300 kg)
- Order number 366 00 03

TECEDrainpoint grate frame stainless steel, 150 mm, incl. design grate

Set consisting of drain top with grate frame (stainless steel) and TECEDrainpoint design grate 142 x 142 mm

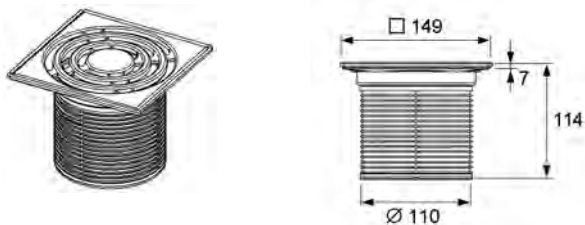

- Drain top made of plastic (ABS)
 - O-ring seal
 - Outer diameter = 110 mm
 - Height adjustment = 4 to 85 mm
 - Grate frame made of drawn stainless steel
 - TECEDrainpoint design grate made of drawn stainless steel, material 1.4301 (304), dimension 100 x 100 mm polished surface, load class K3 (load up to 300 kg)
- Order number 366 00 04

TECEDrainpoint grate frame stainless steel, 100 mm, incl. design grate "quadratum"

Set consisting of drain top extension with stainless steel grate frame and "quadratum" design grate 100 x 100 mm

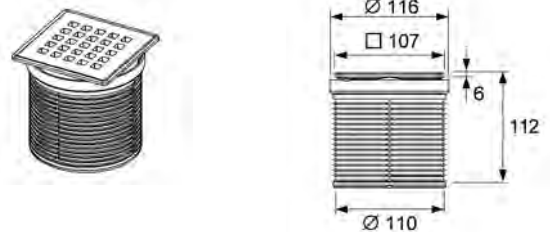

- Drain top made of plastic (ABS)
 - O-ring seal
 - Outer diameter = 110 mm
 - Height adjustment = 7 to 102 mm
 - Grate frame made of drawn stainless steel, material 1.4301 (304)
 - "quadratum" design grate made of stainless steel, material 1.4301 (304), dimension 100 x 100 mm polished surface, load class K3 (load to 300 kg)
- Order number 366 00 07

TECEDrainpoint grate frame stainless steel, 150 mm, incl. design grate

Set consisting of drain top extension with stainless steel grate frame and "quadratum" design grate 142 x 142 mm

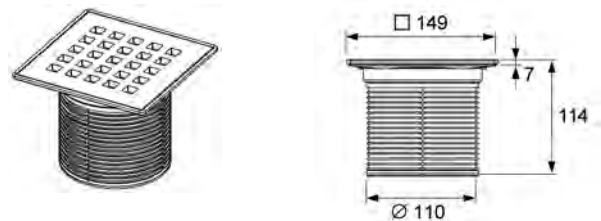

- Consisting of:
- Drain top made of plastic (ABS)
 - O-ring seal
 - Outer diameter = 110 mm
 - Height adjustment = 4 to 85 mm
 - Grate frame made of drawn stainless steel, material 1.4301 (304)
 - "quadratum" design grate made of stainless steel, material 1.4301 (304), dimension 142 x 142 mm polished surface, load class K3 (load to 300 kg)
- Order number 366 00 08

Accessories

TECEdrainpoint raising element with universal flange

Drain top made of plastic with universal flange made of plastic (PP) for thin-bed or strip seals

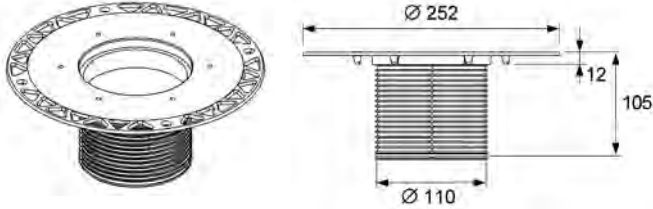

- Flange with matting to connect composite seals or strip seals
 - Incl. O-ring seal
 - Outer diameter = 110 mm
 - Height adjustment = 12.5 to 94.5 mm
- Order number 366 00 05

TECEdrainpoint extension

Drain top extension made of plastic (ABS)
With O-ring seal

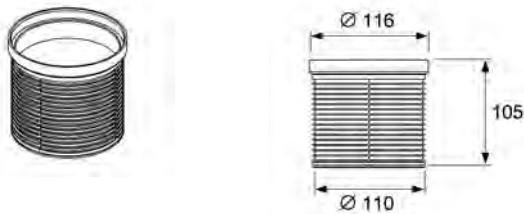

- Outer diameter = 110 mm
 - Height adjustment = 4 to 85 mm
- Order number 366 00 06

TECEdrainpoint design grate stainless steel 100 x 100 mm, screw-down

TECEdrainpoint design grate 100 x 100 mm made of drawn stainless steel, material 1.4301 (304) screw-down



- Dimension = 100 x 100 mm (outer dimensions)
 - Polished surface
 - Load class K3 (load to 300 kg)
 - Incl. 2 stainless steel countersunk screws and self-cutting threaded bushes
- Order number 366 50 00

TECEdrainpoint design grate stainless steel 142 x 142 mm, screw-down

TECEdrainpoint design grate 142 x 142 mm made of drawn stainless steel, material 1.4301 (304) screw-down

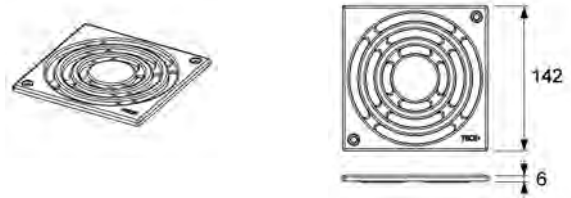

- Dimension = 142 x 142 mm (outer dimensions)
 - Polished surface
 - Load class K3 (load to 300 kg)
 - Incl. 2 stainless steel countersunk screws and self-cutting threaded bushes
- Order number 366 50 01

TECEdrainpoint design grate stainless steel 100 x 100 mm

TECEdrainpoint design grate 100 x 100 mm made of drawn stainless steel, material 1.4301 (304)



- Dimension = 100 x 100 mm (outer dimensions)
 - Polished surface
 - Load class K3 (load to 300 kg)
- Order number 366 50 02

TECEdrainpoint design grate stainless steel 142 x 142 mm

TECEdrainpoint design grate 142 x 142 mm made of drawn stainless steel, material 1.4301 (304)

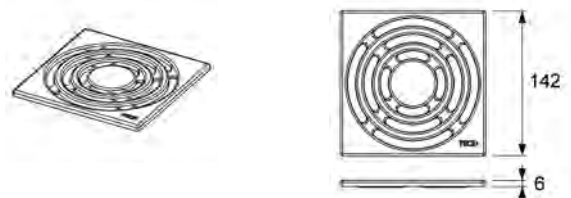

- Dimension = 142 x 142 mm (outer dimensions)
 - Polished surface
 - Load class K3 (load to 300 kg)
- Order number 366 50 03

TECEdrainpoint S – range and technical data

TECEdrainpoint "quadratum" design grate stainless steel 100 x 100 mm

made of stainless steel, material 1.4301 (304)



- Dimension = 100 x 100 mm (outer dimensions)
 - Polished surface
 - Load class K3 (load to 300 kg)
- Order number 366 50 06

TECEdrainpoint "quadratum" design grate stainless steel 142 x 142 mm

made of stainless steel, material 1.4301 (304)

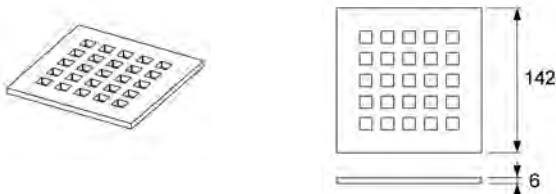

- Dimension = 142 x 142 mm (outer dimensions)
 - Polished surface
 - Load class K3 (load to 300 kg)
- Order number 366 50 09

TECEdrainpoint compression ring stainless steel, incl. screws and seal

Compression sealing ring set for clamped flange connections



- Compression ring made of stainless steel, material 1.4301 (304) with predrilled hole circle
 - Sealing ring made of cellular rubber
 - 6 stainless steel screws
- Order number 369 00 03

TECEdrainpoint seal sleeve for thin-bed seal 480 x 480 mm

Seal sleeve for connecting thin-bed seal, waterproof polypropylene fleece

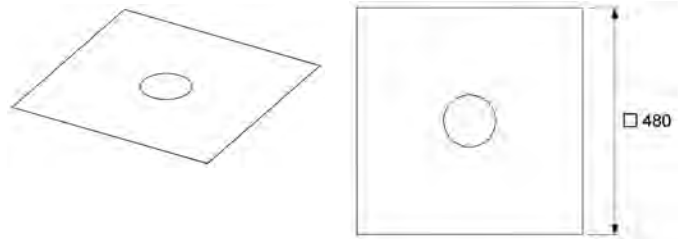

- PP fleece (top and underside) and inner waterproof PE foil
 - Dimension = 480 x 480 mm
- Order number 369 00 04

TECEdrainpoint cut-to-size sealing foil EPDM 480 x 480 mm

Seal sleeve for the connection of bitumen membrane sheets, polymer bitumen membrane sheets or EPDM sealing strips using hot-air welding, full-area welding or gluing with PU adhesive. The seal sleeve is fixed on the universal flange with the compression sealing ring.

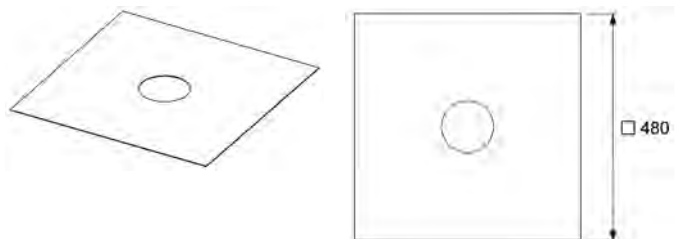

- Material: EPDM with insert of glass cloth, underside with polymer-modified bitumen layer and fine quartz coating
 - Dimension = 480 x 480 mm
 - Material thickness = 3.1 mm
 - Manufacturer: Phoenix Restrix Classic
- Order number 369 00 06

TECEdrainpoint odour trap extra-flat

Odour trap extra-flat made of plastic (PP)



- Reduced sealing water height = 30 mm
 - Can be used for horizontal drains DN 50 extra-flat
- Order number 369 50 00

TECEdrainpoint odour trap standard

Odour trap standard made of plastic (PP)



- Sealing water height = 50 mm in keeping with DIN EN 1253
 - Can be used for all horizontal and vertical drains DN 50 standard, DN 70 and DN 100
- Order number 369 50 01

TECEdrainpoint membrane odour trap

Odour trap made of plastic (PP) with inner sealing lip membrane to protect against odour and evaporation



- Can be used for all horizontal and vertical drains
 - Two-stage odour trap
- Order number 369 50 02

Assembly instructions

Installation of drain with thin-bed sealing

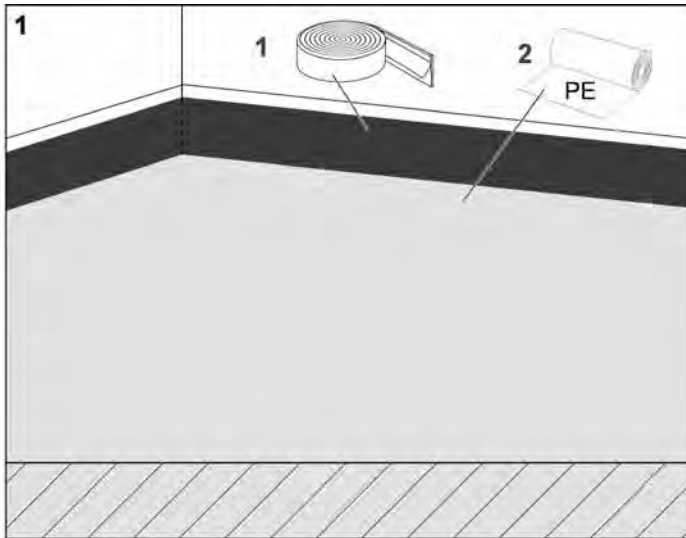

Attach edge insulation strips and lay PE foil.

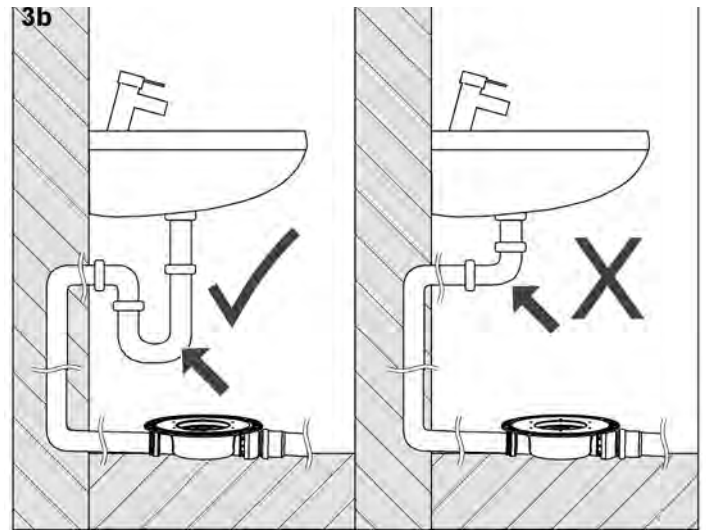

If a lateral inflow is used, an odour trap is required in the inlet pipe.

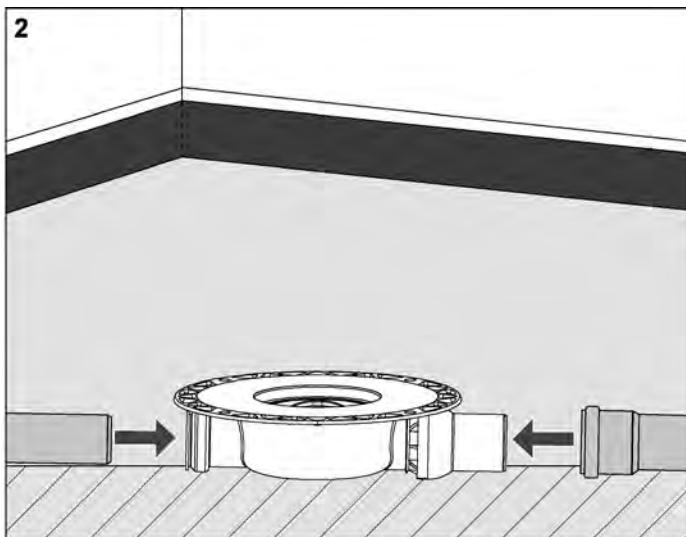

Position drain and connect on the waste-water side. In the case of drains with a vertical socket, a drill hole with a diameter of 130 mm is required.

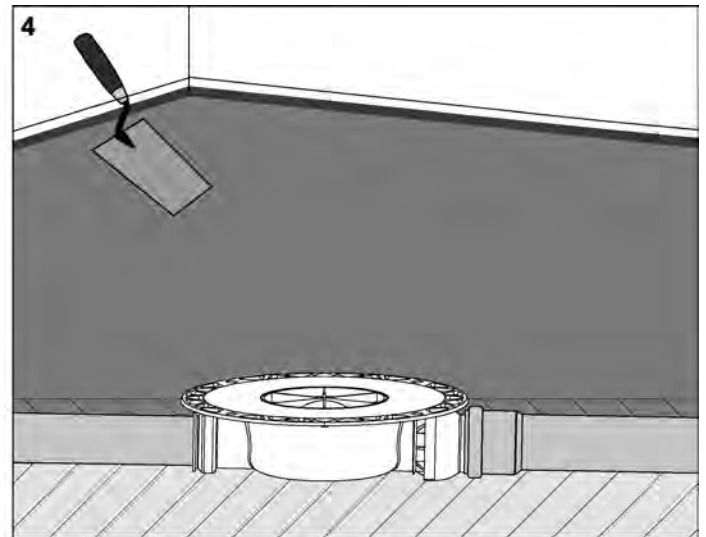

Lay screed.

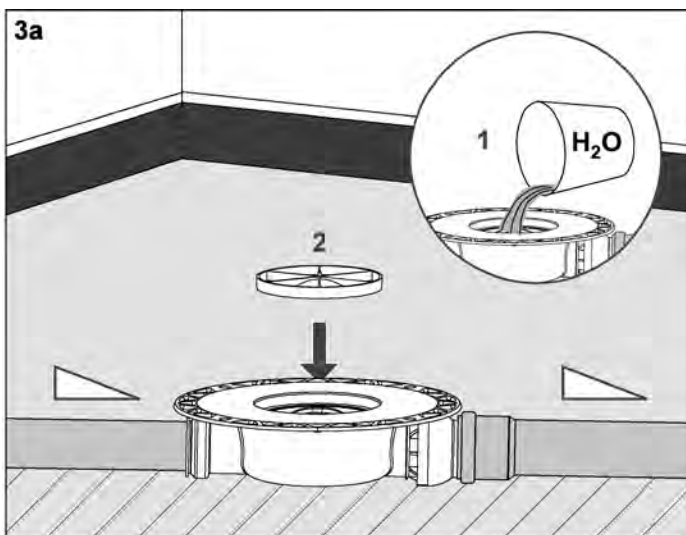

Carry out tightness test.

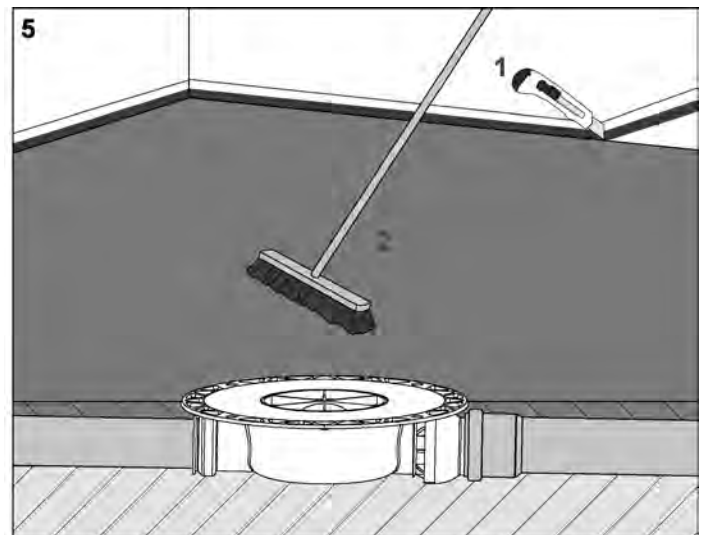

Once dry, cut off excess edge insulation strips and PE foil, clean screed.

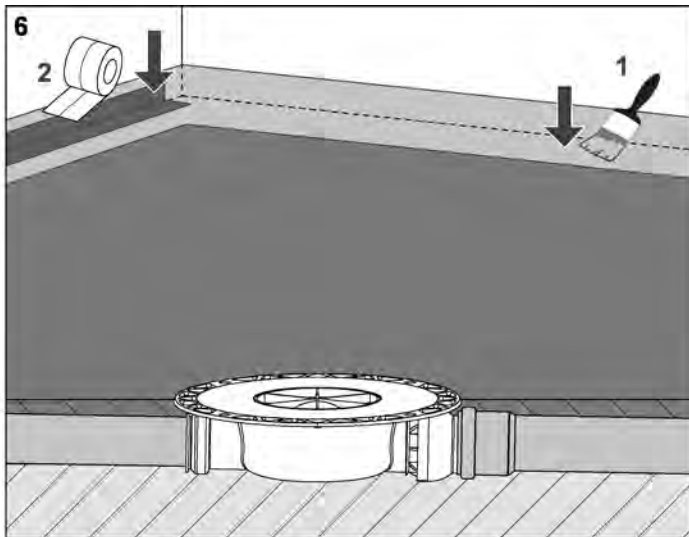

Attach damp-proof coating and sealing tape at the transition between screed and wall (and if necessary to other screed areas).

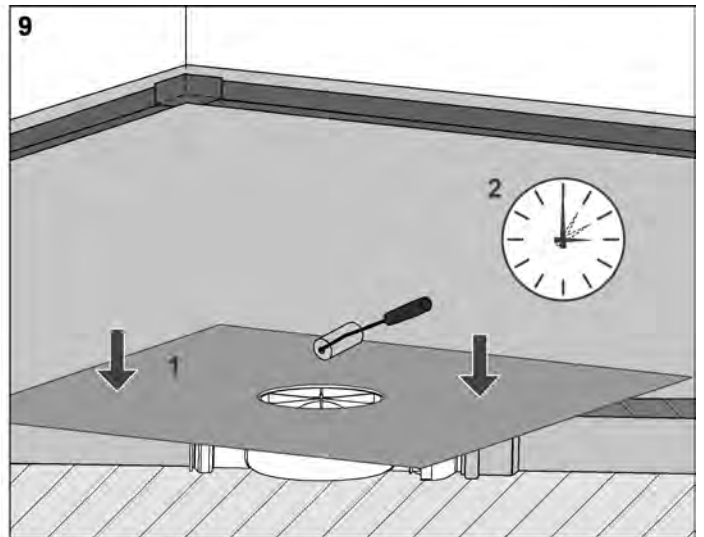

Insert sealing sleeve in fresh coating and press to remove creases. Allow coating to dry.

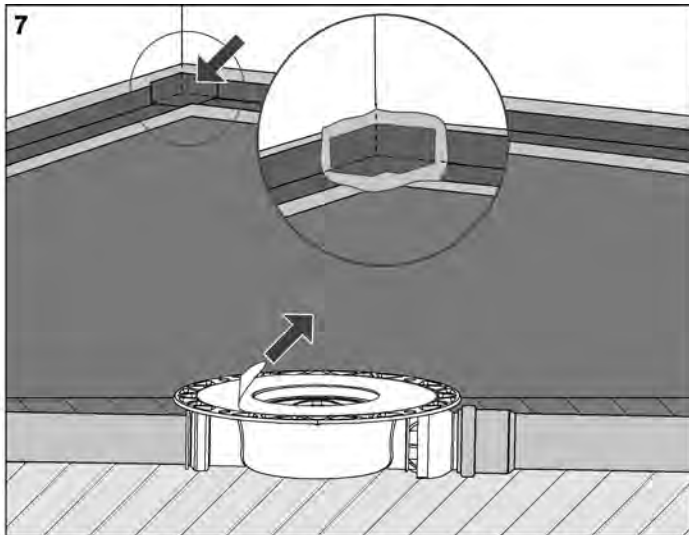

Attach sealing angle(s), remove protective film from flange.

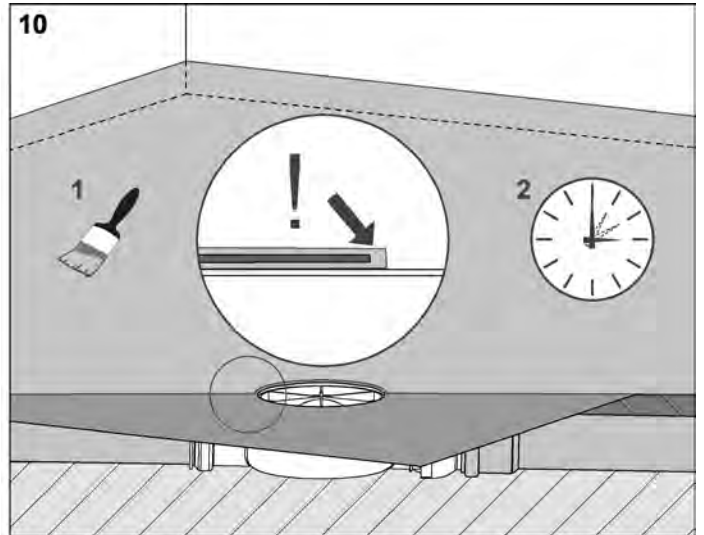

Apply second damp-proof coating over complete area: The sealing sleeve must be completely covered by the damp-proof coating. Allow coating to dry.

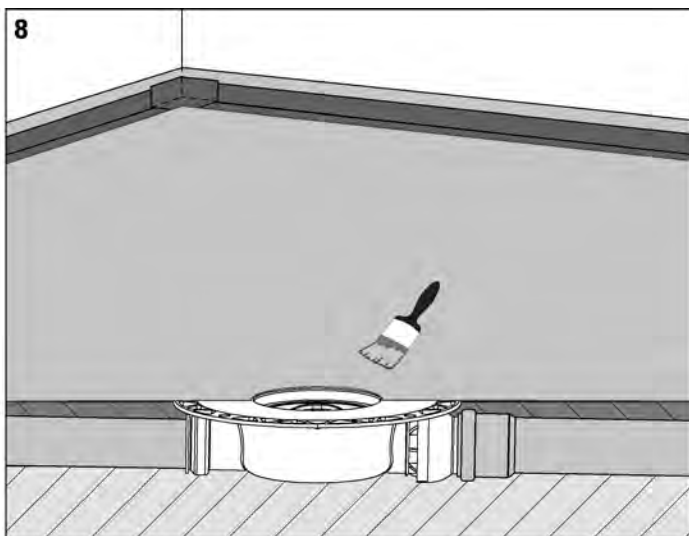

Apply first damp-proof coating over complete area

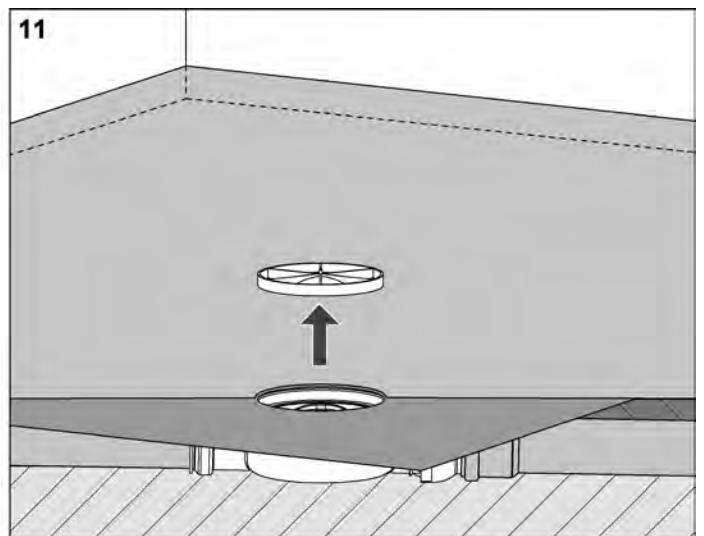

Remove protective cover.

TECEdrainpoint S – assembly instructions

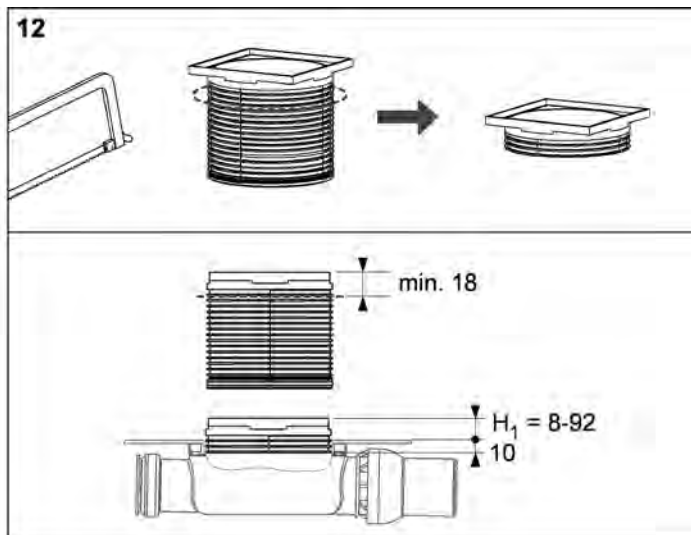

Cut the drain top to length.

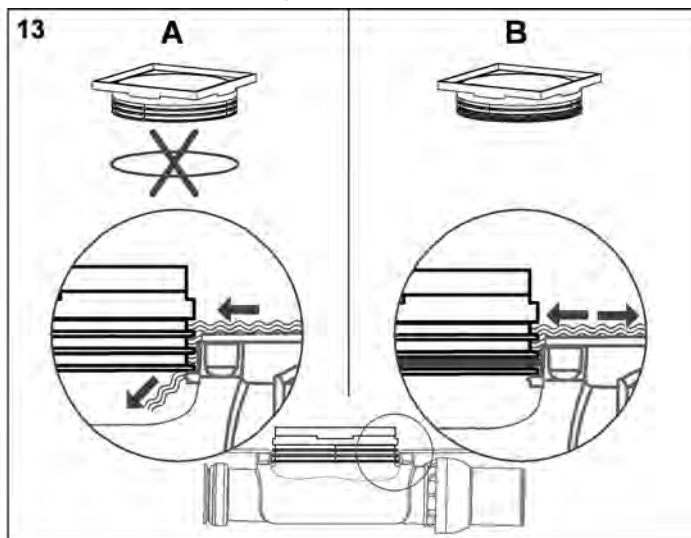

The drainage of seepage water is ensured without an O-ring.

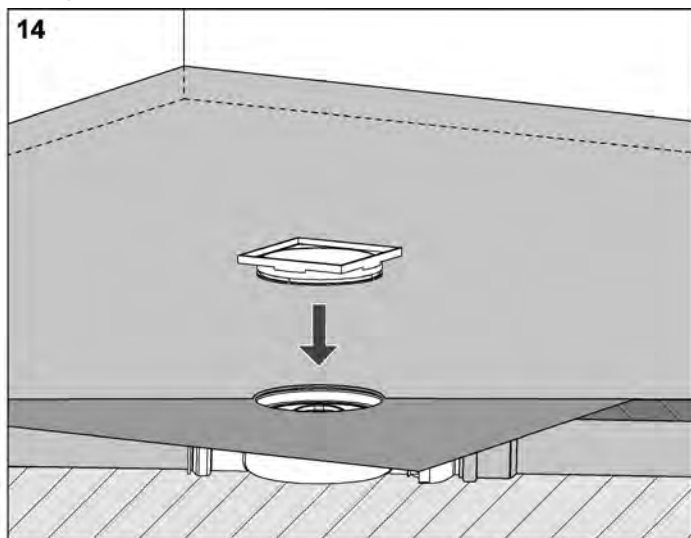

Insert the cropped drain top.

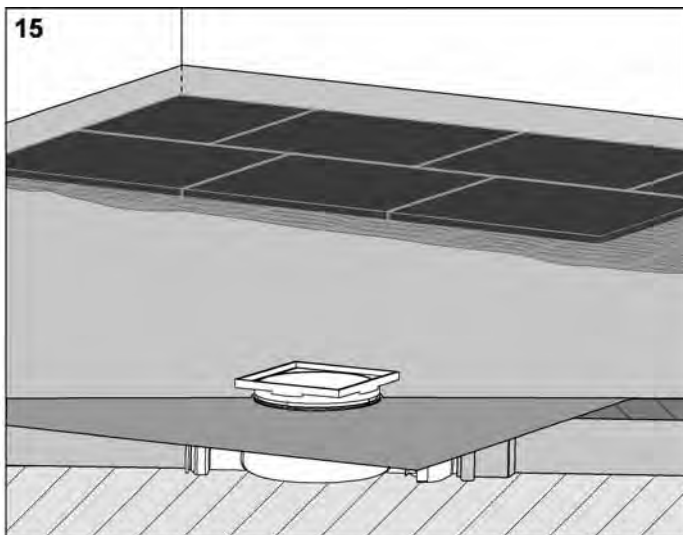

Apply floor covering.

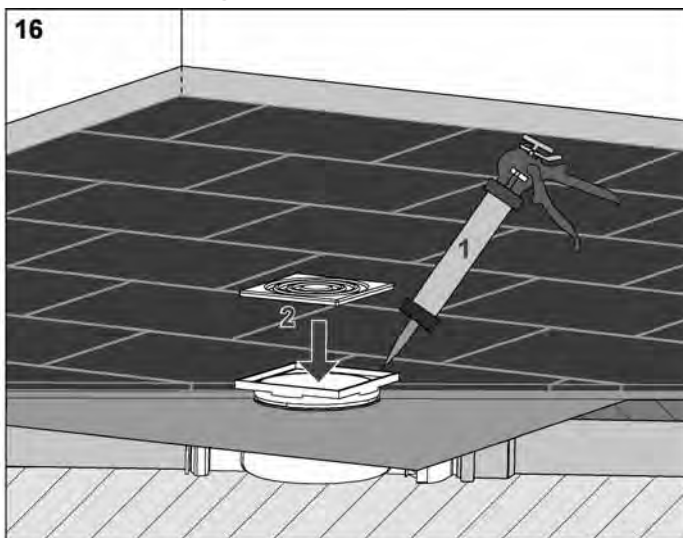

Seal joint with permanently elastic material and install grate.

Installation of drain with clamped flange sealing

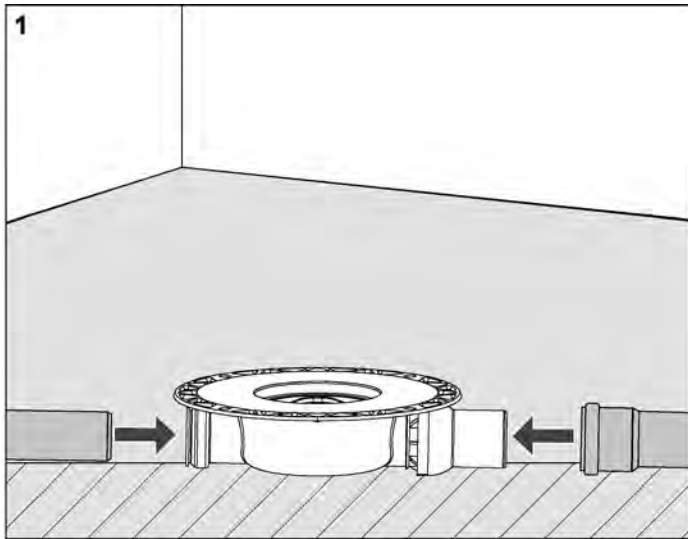

1 Position drain and connect on the waste-water side. In the case of drains with a vertical socket, a drill hole with a diameter of 130 mm is required.

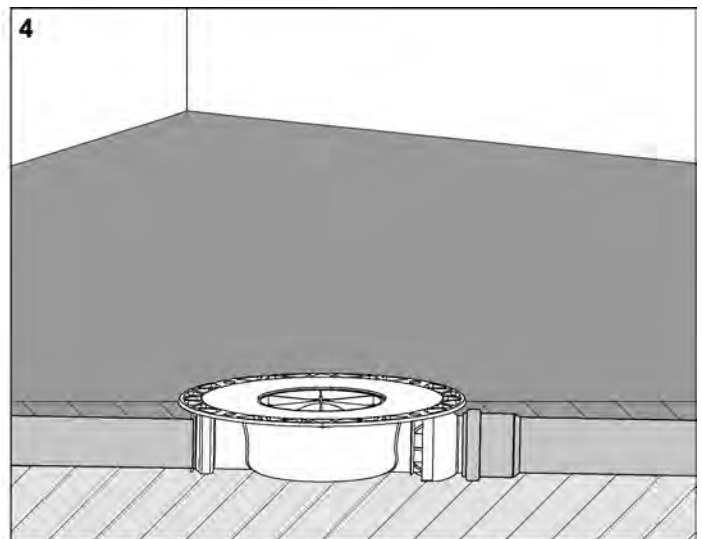

4 Lay screed.

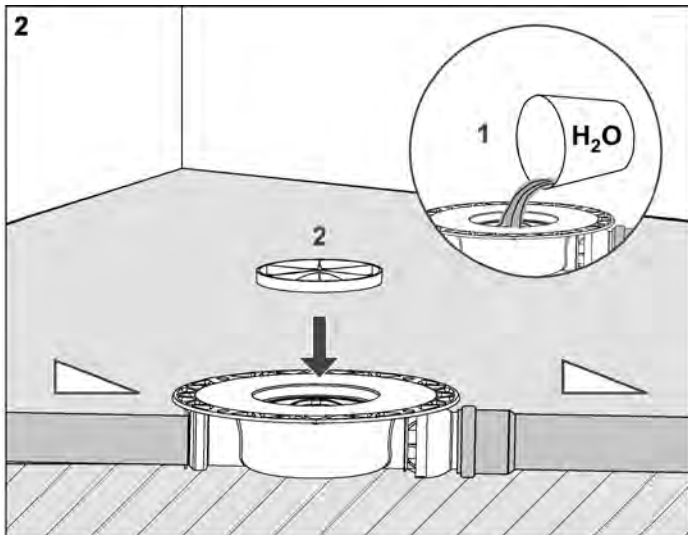

2 Carry out tightness test.

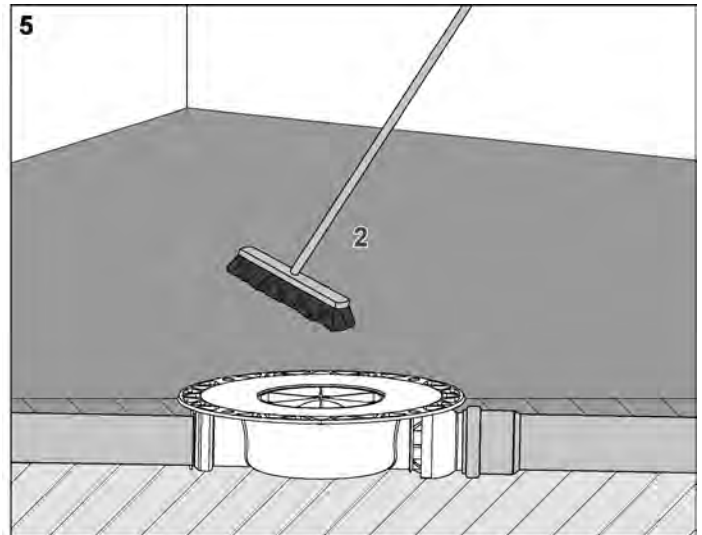

5 Once dry, clean the screed.

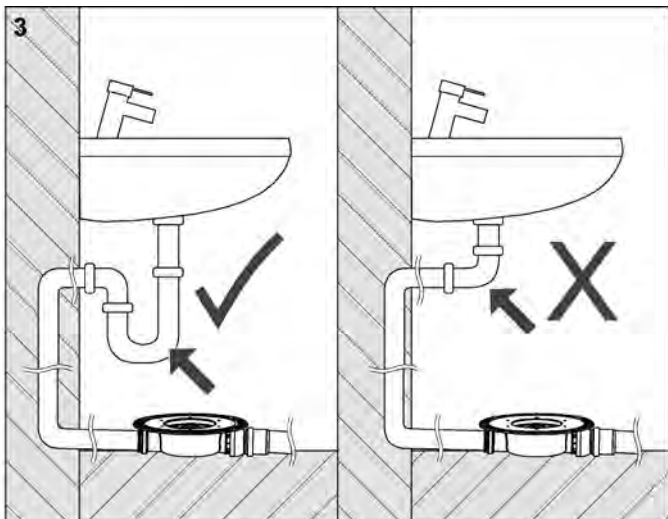

3 If a lateral inflow is used, an odour trap is required in the inlet pipe.

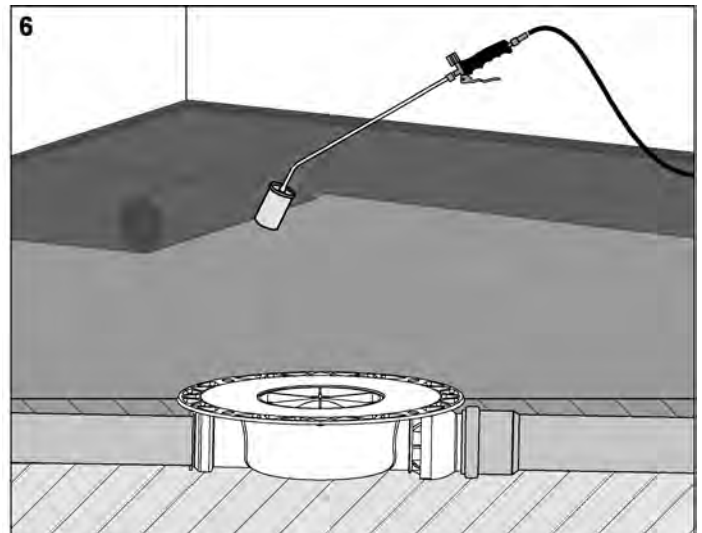

6 Apply sealing strips (bitumen/EPDM) in accordance with manufacturer information.

TECEdrainpoint S – assembly instructions

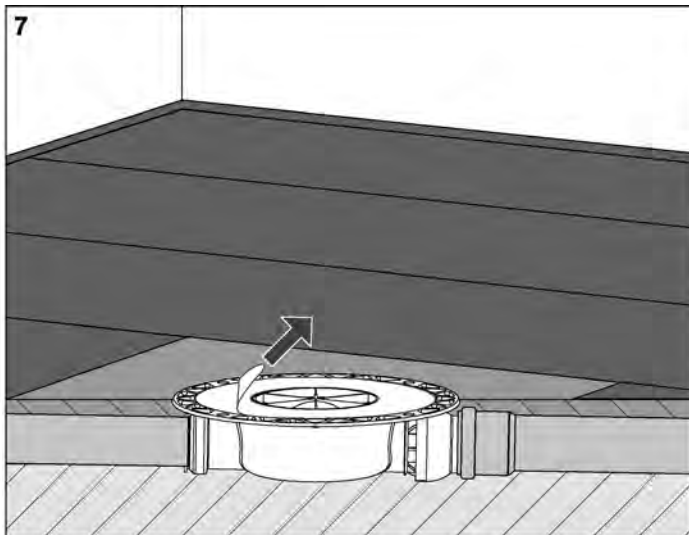

Remove protective foil from flange.

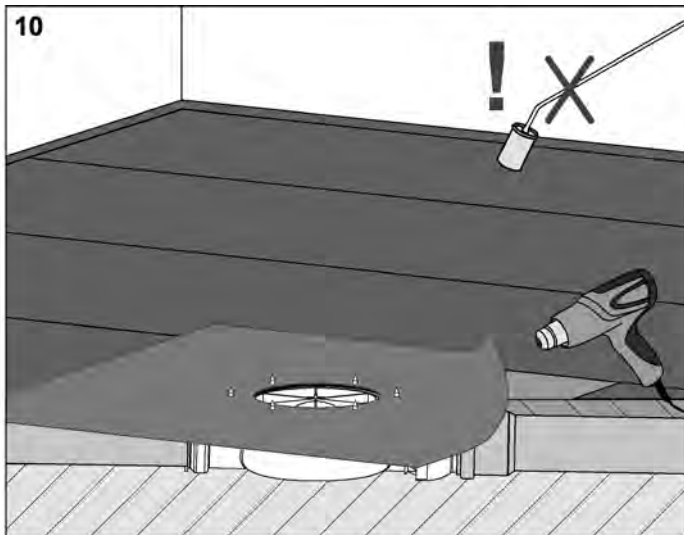

Weld cut-to-size sealing foil with the sealing strip.

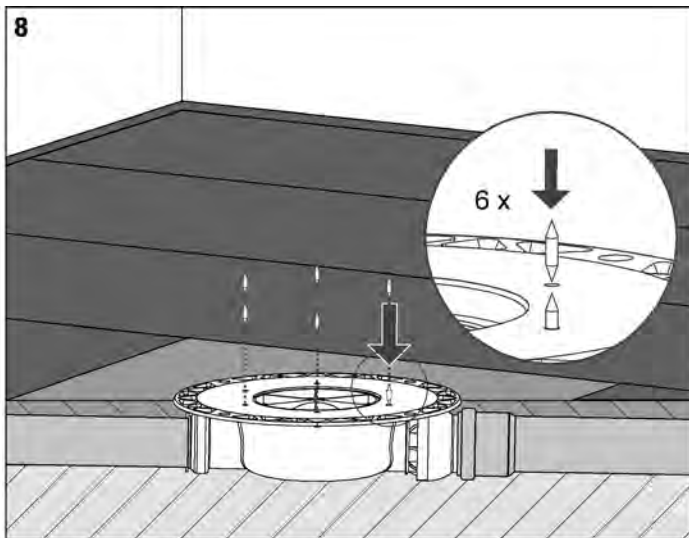

Insert pins for flange assembly (6 x).

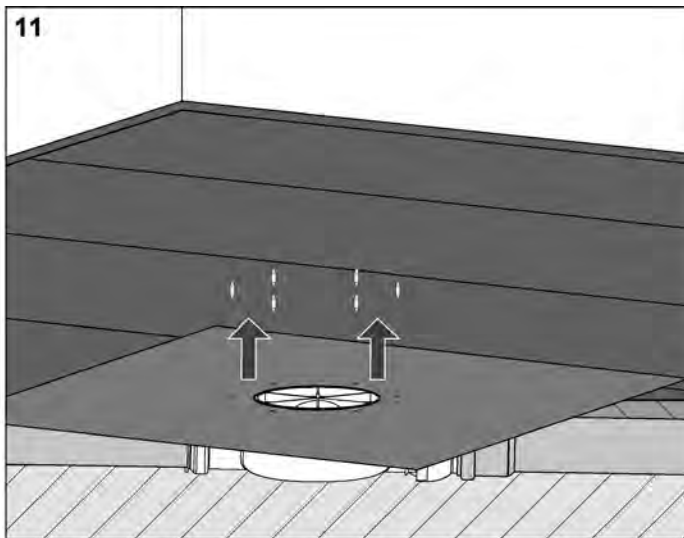

Remove pins.

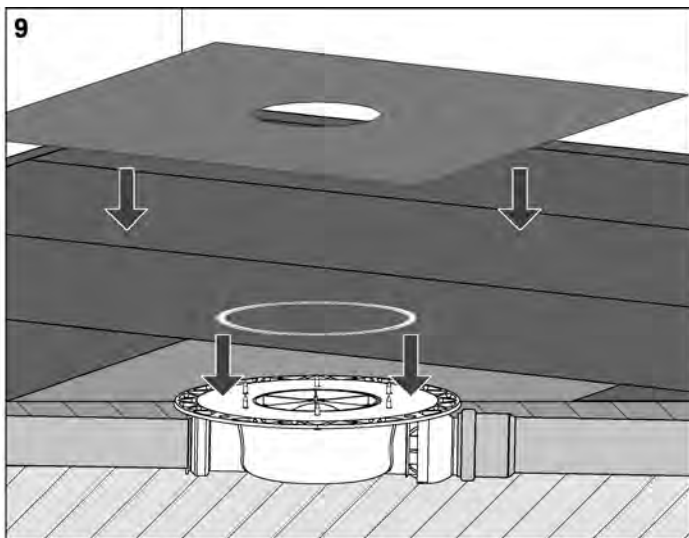

Apply seal and accurately cut sealing foil (EPDM) to size.

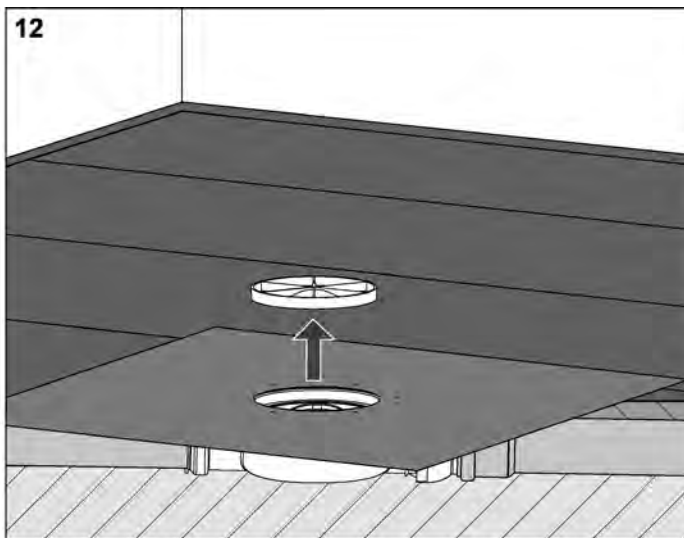

Remove protective cover.

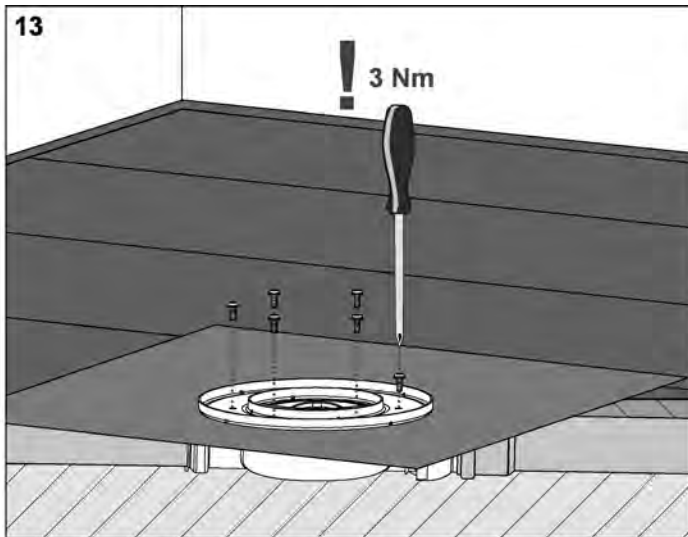

Screw on compression ring (torque 3 Nm!).

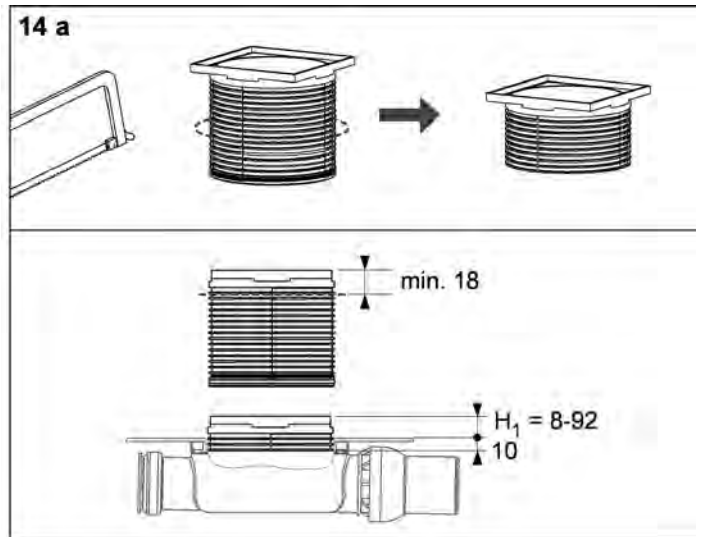

The drain top must be cut to length.

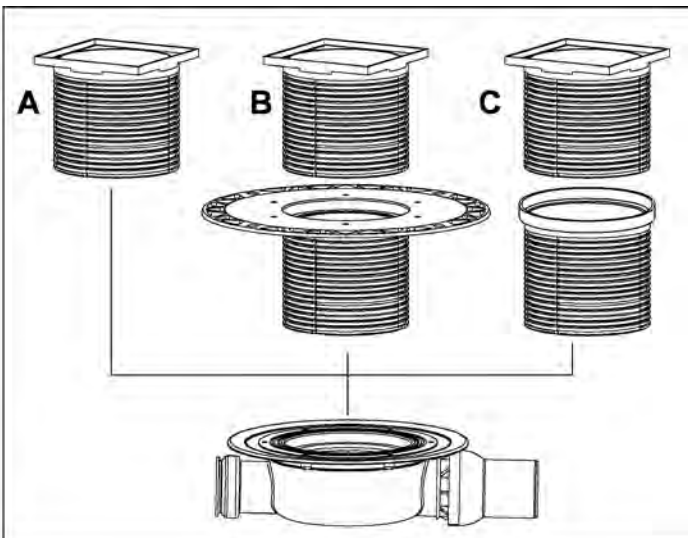

Various drain tops can be used.

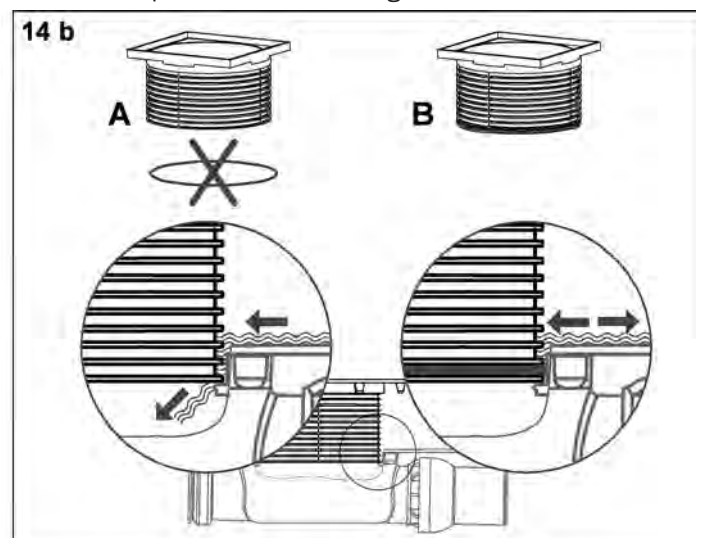

The drainage of seepage water is ensured without an O-ring.

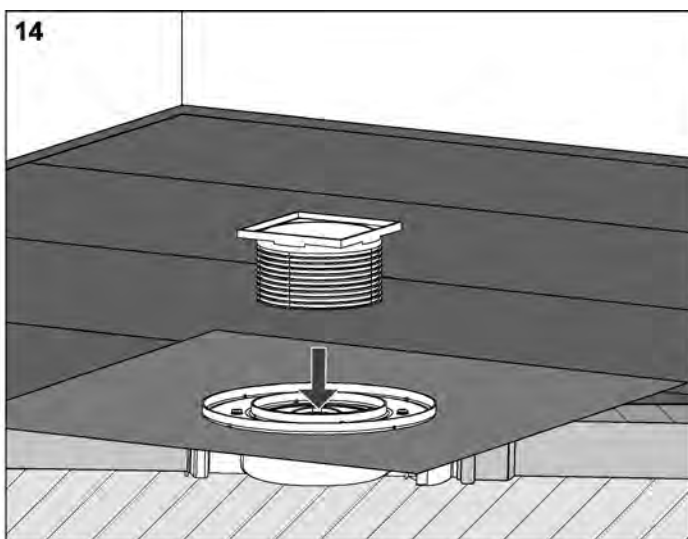

Insert the drain top.

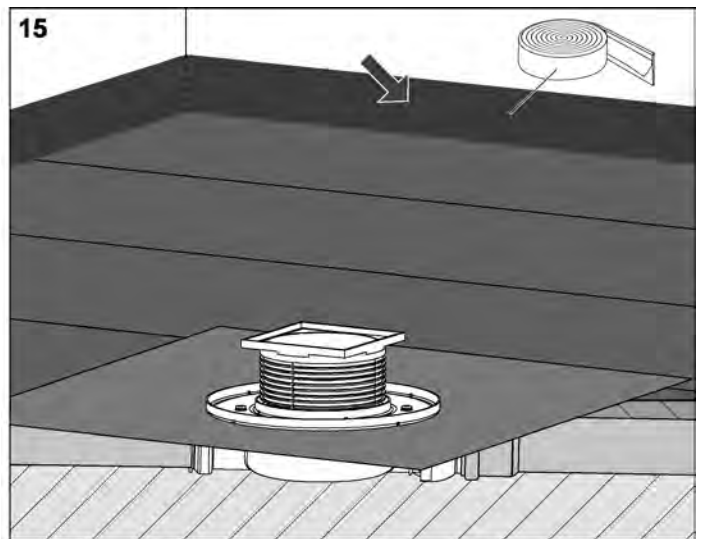

Attach edge insulation stop.

TECEdrainpoint S – assembly instructions

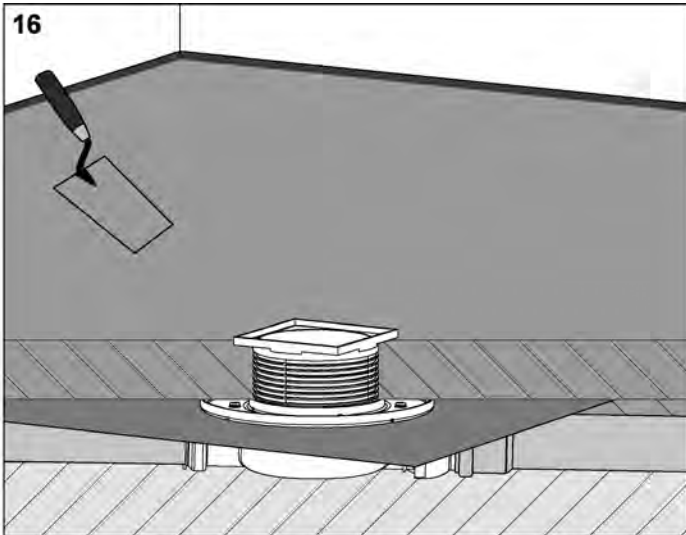

Lay screed.

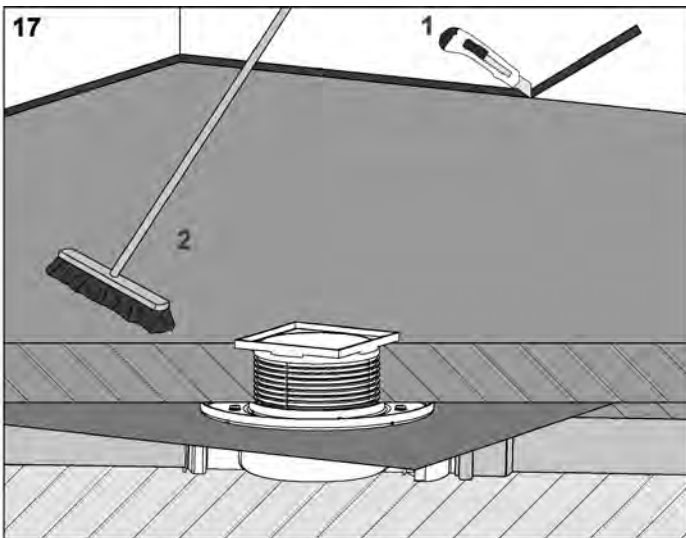

Once dry, cut off excess edge insulation strips and PE foil, clean screed.

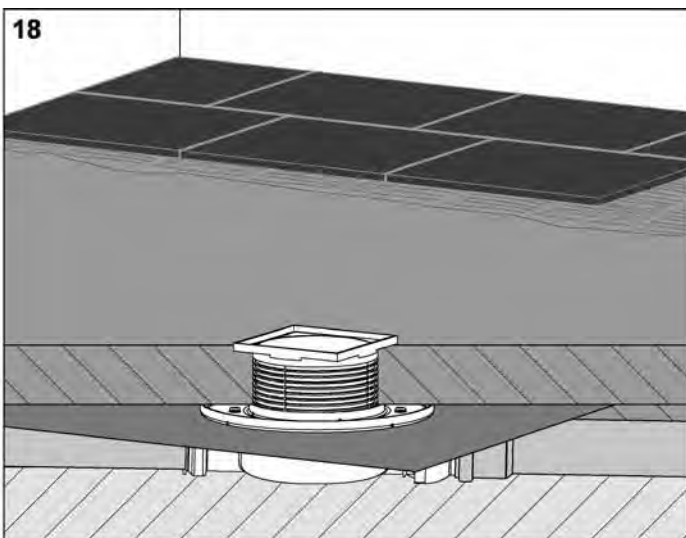

Apply floor covering.

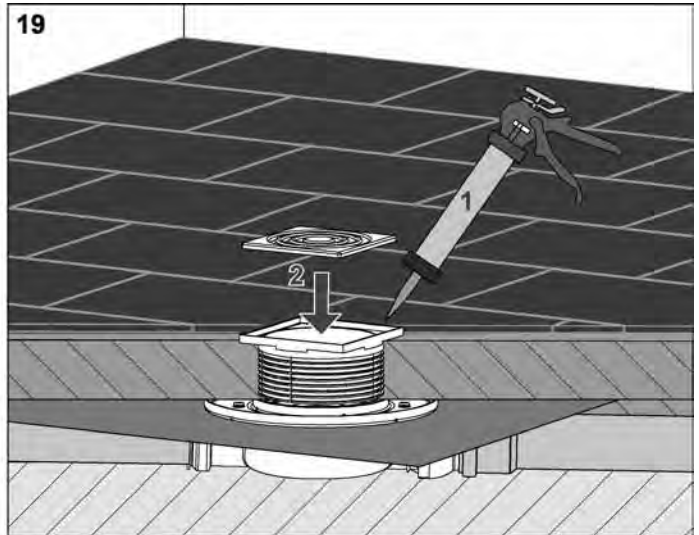

Seal joint with permanently elastic material and install grate.

Installation of drain without flange

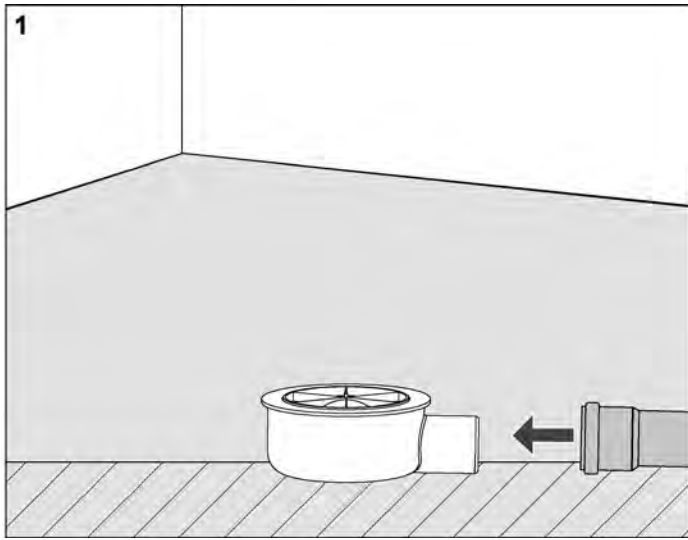

Position the floor drain and connect the waste water pipe.

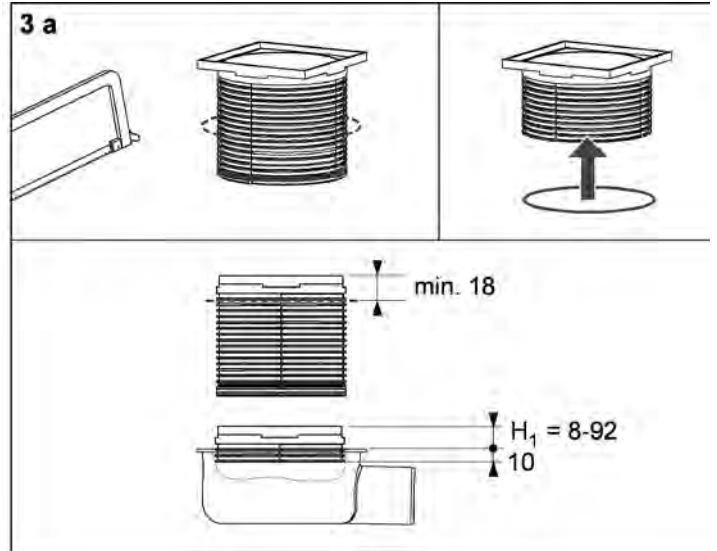

The drain top must be cut to length, the O-ring seal should sit in the lowest groove.

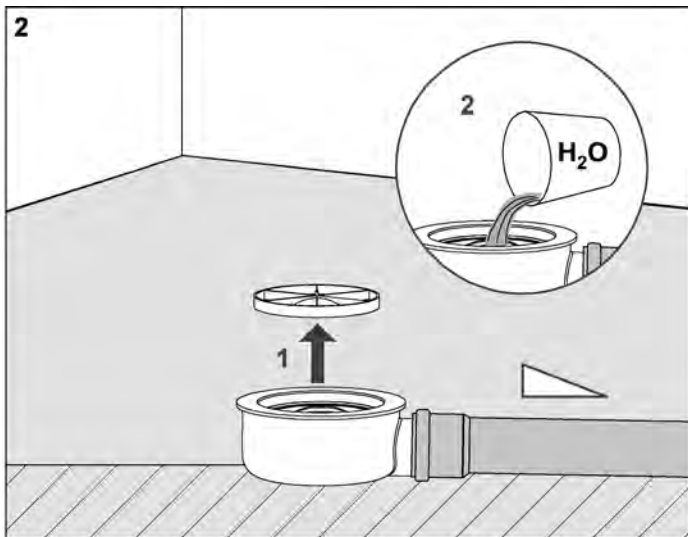

Carry out tightness test.

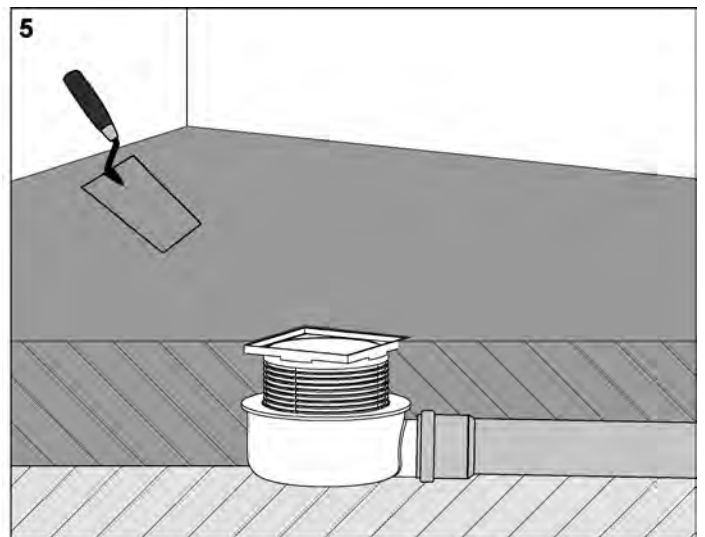

Lay screed or other floor material.

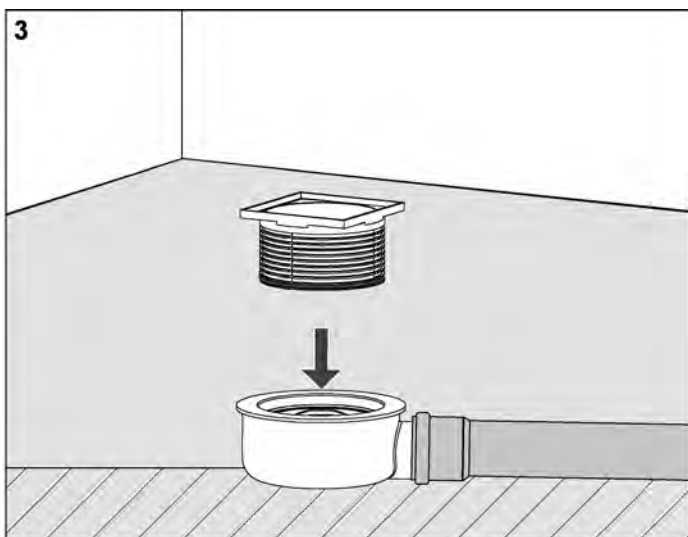

Insert the drain top.

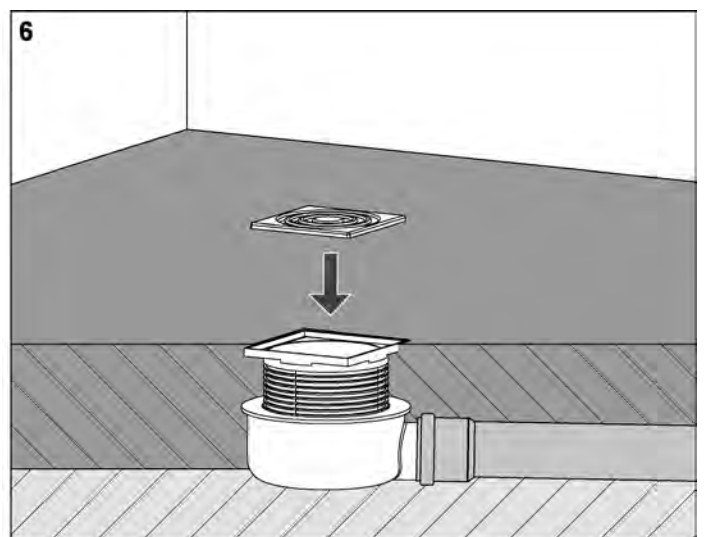

Insert grate.

Standards

DIN 1986: Drainage systems for buildings and land

- Part 3: Rules for operation and maintenance (2004)
- Part 4: Application areas for waste water pipes and mouldings made of various materials (2011)
- Part 30: Maintenance (2012)

DIN 1986-100: Drainage systems for buildings and land/
provisions in connection with DIN EN 752 and
DIN EN 12056 (2008)

DIN 18024 parts 1 and 2: Barrier-free building/publicly
accessible buildings and work places/basis for planning
(1996–1998)

DIN 18040 part 2: Barrier-free building - basis for planning
- residential buildings (2011)

DIN 18195 parts 1 and 10: Building waterproofing
(2009–2011)

DIN EN 12056, DIN 1986 and DIN EN 1610 comment:
Building and land waterproofing (2000)

DIN EN 1253, part 1 to 3: Drains for buildings
(1999–2003)

DIN 4109 (1989): Sound insulation in buildings,
requirements and verification, amendment A1 (2001)

VDI 4100: Sound insulation in residential buildings –
criteria for planning and evaluation (2007)

Model building regulation (MBO) (2002)

ZDB information sheet: Bonded damp-proofing –
information for designing liquid bonded damp-proofing
with cladding and coverings of tiles and slabs for indoor
and outdoor areas (2010)

GIPS information sheet 5: Bathrooms and damp rooms in
timber construction and dry-wall construction (2006)



TECEdrainboard

TECEdrainboard
Technical Guidelines

TECE

Intelligente Haustechnik



Introduction	282
Requirements for building drainage	282
Damp-proofing	283
Outlets	283
Strength	284
TECEDrainboard – the advantages	285
Watertight all the way round	285
Easy adjustment thanks to sub-structure framework	285
Patterned grates	285
Fire protection solution	285
Compact assortment	285
No limits on tile selection	285
Sturdy on the construction site	285
Range and technical data	286
Boards	286
Sub-structure framework	286
Drains	287
Damp-proofing	288
Patterned grates	289
Assembly instructions	290
Drainboard assembly instructions	290
Installation suggestion for flush-level TECEDrainboard shower element	295
Planning	296
Accessible (barrier-free) bathroom design	296
Fire protection	296
Sound insulation	297
Standards	298

Introduction

The flush-level TECEdrainboard shower element was specially developed for fitters. The pressure-resistant surface makes TECEdrainboard fully equipped for use in harsh construction site environments. The stable element made of rigid polyurethane foam can even be used with 2 cm x 2 cm mosaic tiles. Unlike shower elements made of softer polystyrene, there are no limitations when it comes to selecting tiles with TECEdrainboard.

Different drains are available for different structural requirements: with fire protection, in stainless steel or the flat horizontal version for low assembly heights.

Solid, design-oriented grate covers round off the range.

TECEdrainboard is extremely robust and strong on the construction site and in the finished bathroom. The total assembly height of the easy-to-install system is adjustable from 13 to 18 cm, incl. sound-insulated sub-structure framework made of steel.

This height-adjustable sub-structure framework enables easy adjustment to the screed height. The robust shower element is laminated with a special watertight matting, and comes fitted with the necessary gradient for the drain outlet. To ensure a better seal for the interfaces, the special matting is slightly larger than the actual shower element.



Requirements for building drainage

Damp-proofing

According to the building regulations of the German federal states, buildings are to be designed so that "risks or unreasonable strain do not arise through water, dampness [...] or other chemical, physical or biological influences." Parts of a building affected by damp, such as bathrooms, shower rooms, balconies, commercial kitchens and so on, must therefore be protected against moisture penetration. Rooms or parts of a building exposed to dampness are usually clad or given a covering made of tiles and slabs. These coverings are damp-resistant and water-repellent, but depending on the type of jointing are in all cases so water-permeable that additional damp-proofing is usually required.

The ZDB information sheet describes bonded damp-proofing with tiles and slabs in indoor and outdoor areas taking account of defined dampness intensities and subsurfaces.

The thin-bed seals (bonded damp-proofing) shown have proven their worth effectively in practical applications. As a rule, the information sheet is an important basis for correct planning and application. In addition, the specific installation information in the TECE installation instructions should be observed.

When structures are designed in accordance with this information, the covering and cladding with tiles and slabs in a thin bed provide a protective layer. In the case of floor structures with insulation layers, this damp-proofing is placed directly on top of the load distribution layer (screed). The covering can be laid in the thin bed on top of this, so additional protective layers are usually not required.

Notes:

- This damp-proofing has limited crack bridging. TECEdrainboard is therefore offered as standard with integrated water-impermeable special matting and overlapping (of 4 cm) on the reverse side, which is embedded in the thin-bed seal in the transition area.
- To avoid discrepancies, the type of sealing should generally be defined in the contract.

The advantages of thin-bed sealing:

- No moisture from hygienically and/or chemically critical liquids can penetrate the subsurface.
- Low-cost alternative to the damp-proofing defined in DIN 18195.

Outlets

The main design requirements relating to floor drains, such as drainage capacity, are described in DIN EN 1253. The table shows the minimum drain values for floor and roof drains (not for syphonic drainage). The minimum drain value with odour trap with lateral connections can be assumed to be 0.4 l/s for drainage of water from a shower head.

The drainage values for drains with one or more inlets can be found in DIN EN 1253-1 section 8.11.2.

Nominal value of the drain connector		Floor drains	
DN / OD	DN / ID	Drainage values	Water height a
32	30	0.4 l/s	20 mm
40	40	0.6 l/s	20 mm
50	50	0.8 l/s	20 mm
75	70	0.8 l/s	20 mm
110	100	1.4 l/s	20 mm
125	125	2.8 l/s	20 mm
160	150	4.0 l/s	20 mm

Drainage capacity (inflow via the grate) – minimum drainage values for drains

TECEDrainboard – requirements for building drainage

Strength

Drains, extensions and grates must be designed so that they can withstand the expected loads (e.g. including vehicular traffic). These classifications for installation within buildings are described in DIN EN 1253-1.

TECEDrainboard meets the requirements of load class K 3.

Load class	Max. permitted load	Area of application/location of use
H 1.5	< 150 kg	For unused flat roofs such as roofs with bitumen gravel, gravel roofs and similar
K 3	< 300 kg	For areas without vehicular traffic, such as bathrooms in residential buildings, hotels, old people's homes, schools, swimming pools, public wash rooms and showers, balconies, loggias, terraces and green roofs.
L 15	< 1.5 t	For areas with light vehicular traffic, excluding fork lift trucks, in commercially used rooms.
M 125	< 12.5 t	For areas with vehicular traffic, such as car parks, factories and workshops

Strength according to DIN EN 1253-1

TECEDrainboard – the advantages

Watertight all the way round

The sealing foil applied in the factory ensures that the shower element is 100% watertight. As a result of the 4 cm overlapping of the water-impermeable special matting on all four sides, reliable sealing of the critical transitions in the wall and floor area is ensured.

Easy adjustment thanks to sub-structure framework

The continuously height-adjustable sub-structure framework permits the flexible adjustment of the shower element from 130 mm to 180 mm – flush to the top of the screed floor – and installation-friendly positioning of the floor drain thanks to the integrated fixing unit.

A key advantage here is the time saving achieved as long drying times are not necessary. The conventional installation of the shower element on a levelling course is not necessary, but is possible as an alternative.

Patterned grates

TECEDrain patterned grates are available for customers with high interior design standards. Customer-specific logos or names can also be produced on request.

Fire protection solution

For buildings that need to meet fire protection requirements, a tested fire resistant floor drain with fire resistance class R 90 in stainless steel is available.

Compact assortment

The solid floor element is available in five rectangular sizes from 900 mm to 1500 mm.

The miniboard □300 mm is suitable for showers with an eccentric drain.

The hygienic, easy-to-clean floor drains made of plastic are available with a horizontal or vertical drain socket.

No limits on tile selection

Because of the high compression strength, the floors can withstand wheelchair use, even with mosaic tiles (2 cm x 2 cm). As a result, the building client can be flexible in the selection of tiles.

Sturdy on the construction site

The extremely compression-resistant surface makes TECEDrainboard well suited for use in harsh construction site environments.

TECEDrainboard – range and technical data

Range and technical data

Boards



Shower element TECE drainboard

Flush-level TECEDrainboard shower element made of PUR, with integrated water-tight special matting and overlap (40 mm) on the reverse side, for the reliable sealing of transitions in the floor and wall area, with factory gradient of 2–3 % to the central drain, directly tileable, wheelchair-accessible for all tile formats (including mosaic), with self-sealing screw connection for the central drain. The smallest shower element – with dimensions 300 mm x 300 mm x 30 mm – is suitable for showers with an eccentric drain.

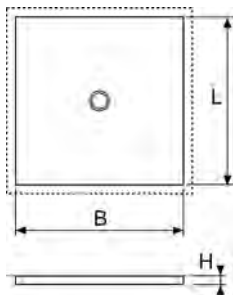
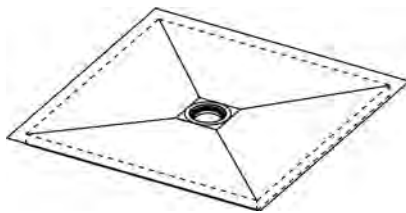

Order no.	Dimensions in mm (L x W x H)
680030	300 x 300 x 30
680090	900 x 900 x 40
680100	1000 x 1000 x 40
680120	1200 x 1200 x 40
680129	1200 x 900 x 40
680150	1500 x 1500 x 40

Dimensions TECEDrainboard shower element

Sub-structure framework



TECEDrainboard sub-structure framework

Sub-structure framework for TECEDrainboard made of steel, powder-coated, with variable height adjustment of the sub-structure framework from 90 mm minimum to 140 mm maximum, for flexible adaptation to the required floor level with fixing unit for central drain. Fast installation as no filling required on the construction site, flexible adaptation to the floor level.

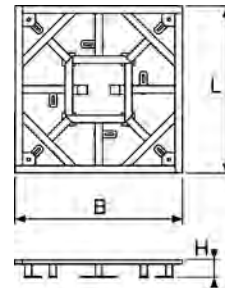
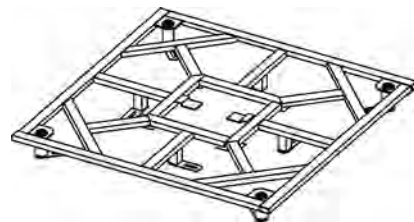

Order no.	Dimensions in mm (L x W x H)
681090	900 x 900 x min. 90–140
681100	1000 x 1000 x min. 90–140
681120	1200 x 1200 x min. 90–140
681129	1200 x 900 x min. 90–140
681150	1500 x 1500 x min. 90–140

Dimensions TECEDrainboard sub-structure framework

Drains



Floor drain TECEdrainboard, horizontal

TECEdrainboard floor drain made of plastic, suitable for flush-level TECEdrainboard shower element, DN 50 drain socket, vertical (1.5° socket gradient), drainage capacity 0.8 l/s, for connection to HT pipe in keeping with German standard DIN 19560, with sealing insert and compression valve, with removable odour trap, 50 mm sealing water height, with protective building time cover and screw aid. With drain top made of plastic, continuously height-adjustable and rotatable, with three compensating rings (2, 3 and 4 mm) for fixing the height of the grate frame, grate frame made of plastic \square 100 mm, with slot grate made of stainless steel, load-bearing to 300 kg.

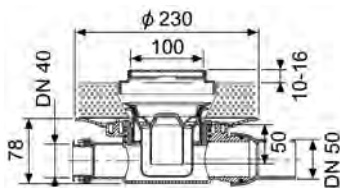

Floor drain horizontal, order number 685001



Floor drain TECEdrainboard, vertical

TECEdrainboard floor drain made of plastic, suitable for flush-level TECEdrainboard shower element, DN 50 drain socket, vertical (90° socket gradient), drainage capacity 0.8 l/s, for connection to HT pipe in keeping with German standard DIN 19560, with sealing insert and compression valve, with removable odour trap, 50 mm sealing water height, with protective building time cover and screw aid. With drain top made of plastic, continuously height-adjustable and rotatable, with three compensating rings (2, 3 and 4 mm) for fixing the height of the grate frame, grate frame made of plastic \square 100 mm, with slot grate made of stainless steel, load-bearing to 300 kg.

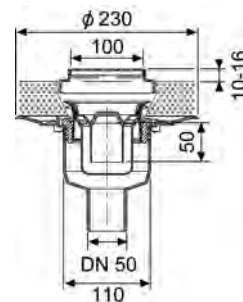

Floor drain vertical, order number 685000

TECEDrainboard – range and technical data



Floor drain TECEDrainboard-Fire-Stop vertical

TECEDrainboard Firestop fire resistant drain made of stainless steel, suitable for flush-level TECEDrainboard shower element, DN 50 drain socket, vertical (90° socket gradient), drainage capacity 0.8 l/s, for connection to HT pipe in keeping with German standard DIN 19560, with sealing insert and compression valve, with removable fire resistant odour trap VA-50E made of stainless steel (fire resistance class R 90, AbP: P-MPA-E-04-010), sealing water height 60 mm, with protective cover for the construction site and screw aid. With drain top made of plastic, continuously height-adjustable and rotatable, with three compensating rings (2, 3 and 4 mm) for fixing the height of the grate frame, grate frame made of plastic □100 mm, with slot grate made of stainless steel, load-bearing to 300 kg.

Caution: Installation with sub-structure framework not possible!

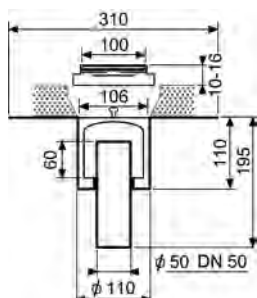
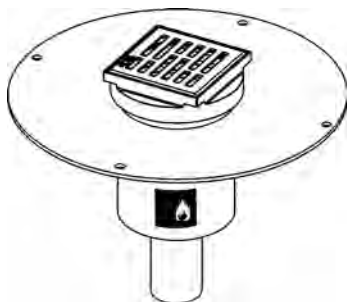

Fire resistant floor drain order number 685002

Damp-proofing

To ensure a better seal for the interfaces, the special matting is slightly larger than the actual shower element. Internal and external angles and a sealing tape made of the same material are also available as an option. The matting bonds perfectly to tile adhesive or sealing coatings. The TECEDrainboard sealing layer is therefore absolutely water-tight if applied correctly.

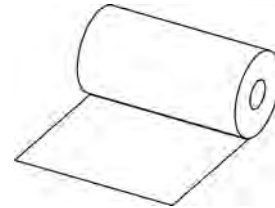

TECEDrainboard sealing tape

- Water-impermeable sealing tape for flush-level TECEDrainboard shower element.
- Roll length 5 m, width 0.1 m
- Order number 686000

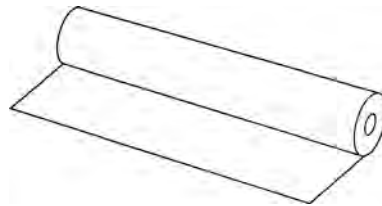

Sealing fleece for TECEDrainboard and TECEDrainline

- Water-impermeable sealing tape for the complete floor area
- Roll length 30 m, width 1 m
- Order number 668023

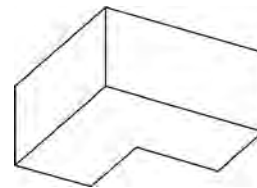

TECEDrainboard external sealing angle

- Water-impermeable external sealing angle for flush-level TECEDrainboard shower element.
- Order number 686001

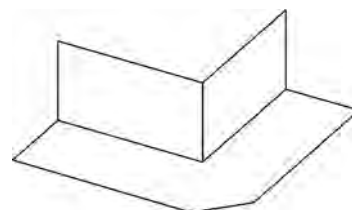

TECEDrainboard internal sealing angle

- Water-impermeable internal sealing angle for flush-level TECEDrainboard shower element.
- Order number 686002

Patterned grates

You can also use patterned grates instead of the slot grate supplied as standard.

- Solid stainless steel, polished
- □ 100 mm
- Load class L 15

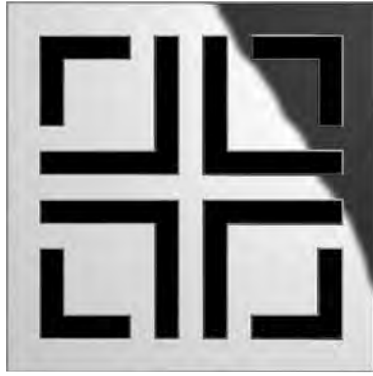

Patterned grate "royal 2", order number 310 00 02



Patterned grate "rings", order number 310 00 03

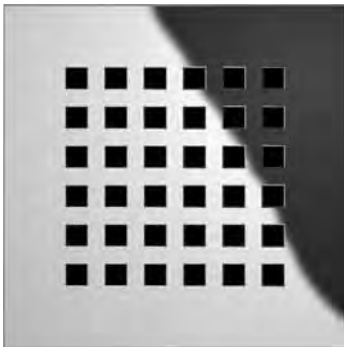
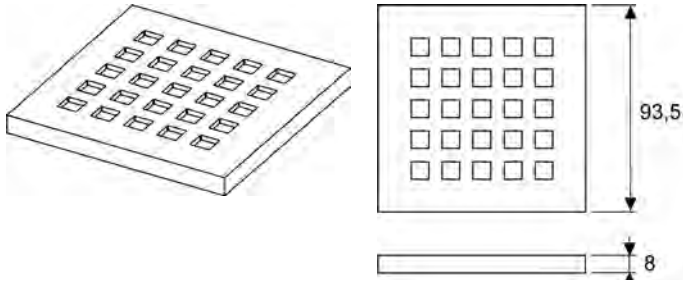

Patterned grate "quadratum", order number 310 00 00

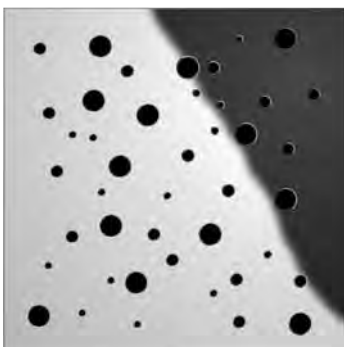

Patterned grate "drops", order number 310 00 01

Assembly instructions

Drainboard assembly instructions

As early as the planning stage, the installation of the wheelchair-accessible shower element should be taken into consideration, in particular the construction height, shower element size, drain connection and – in public buildings – the fire protection requirements. The screed recess in the shower area should take account of the dimensions for TECEdrainboard plus a markup of 15 mm for both element sides – for edge insulation strips and movement joints.

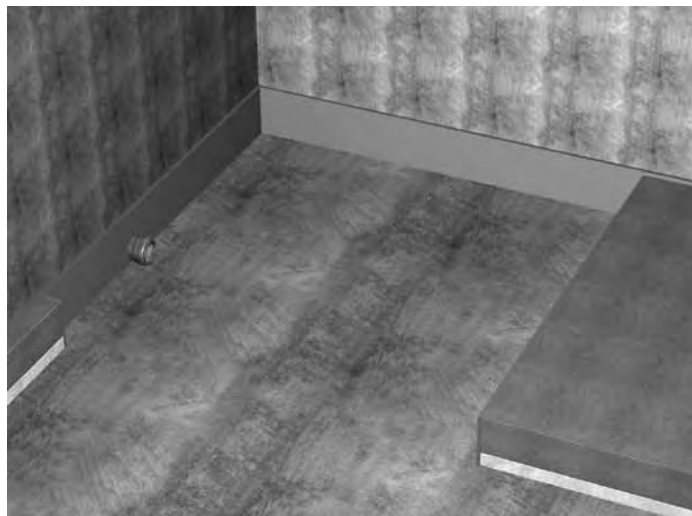

The installation of the shower element is described step by step below, taking account of three different installation situations:

- A: Shower element with floor drain horizontal,
- B: Shower element with floor drain vertical,
- C: Shower element with sub-structure framework (and floor drain horizontal).

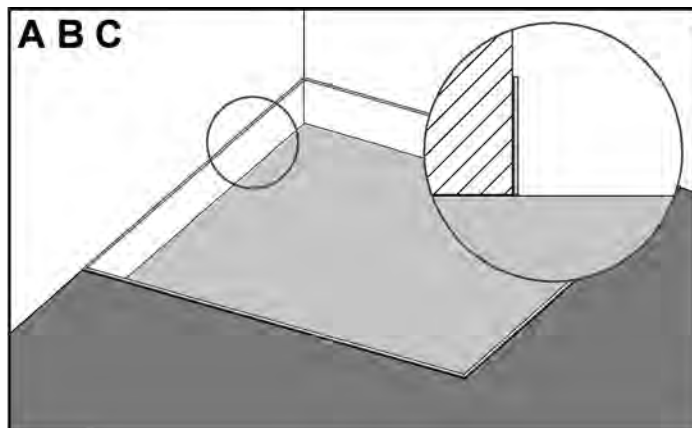

Attach edge insulation strips on all sides.

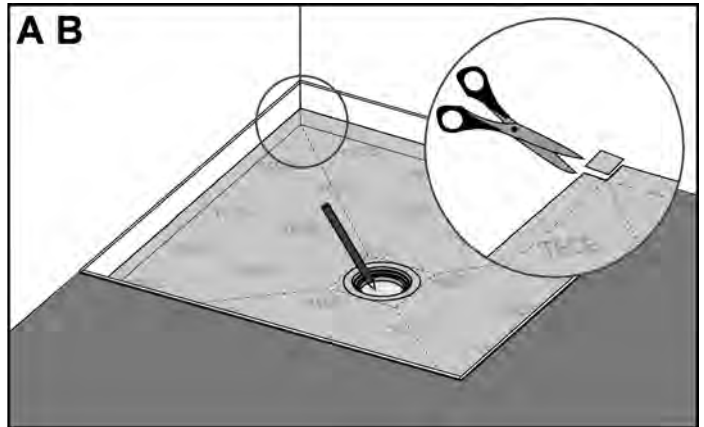

For ideal sealing, cut the sealing fleece in at the corners and mark the position of the drain.

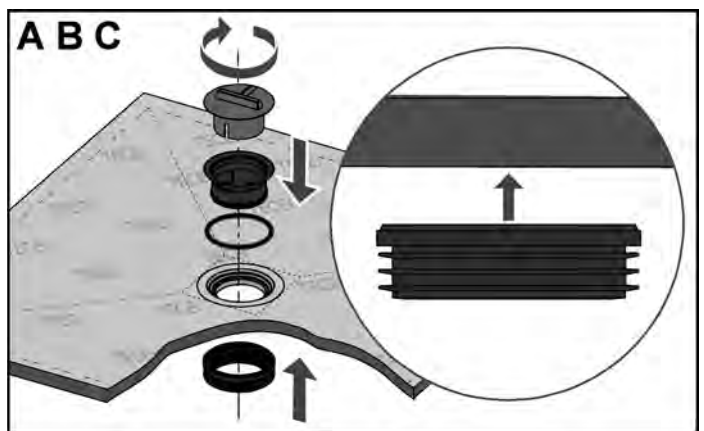

Press the screw compression valve into the shower board from below. Insert sealing ring and press the upper screw valve into the lower one using the screw aid.

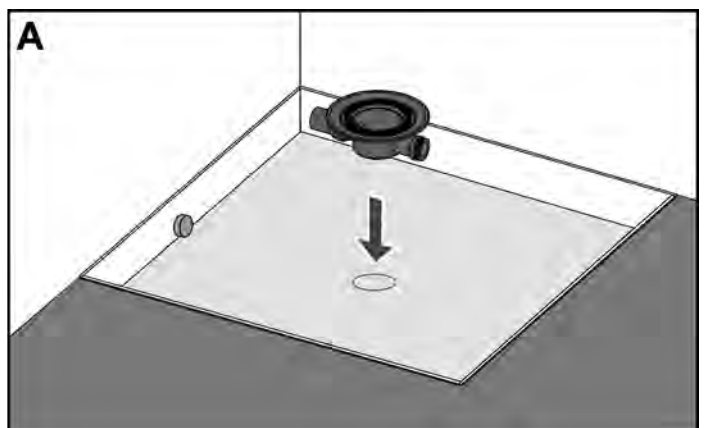

Place the horizontal drain on the marking.

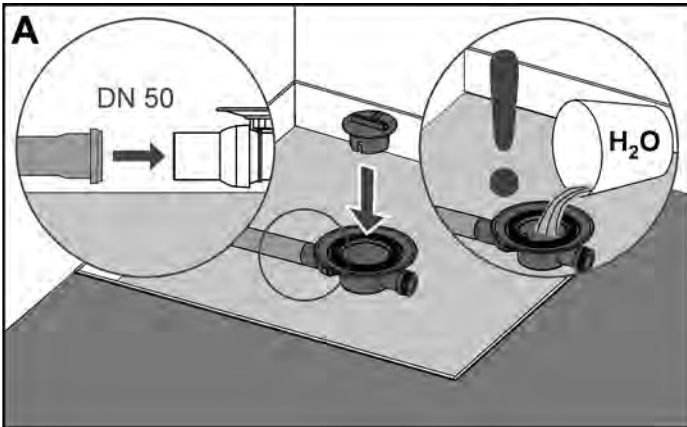

Connect the drain socket from the floor drain to the HT pipe at the intended drain connection point. Carry out tightness test: Fill water in the drain and carry out a visual inspection.

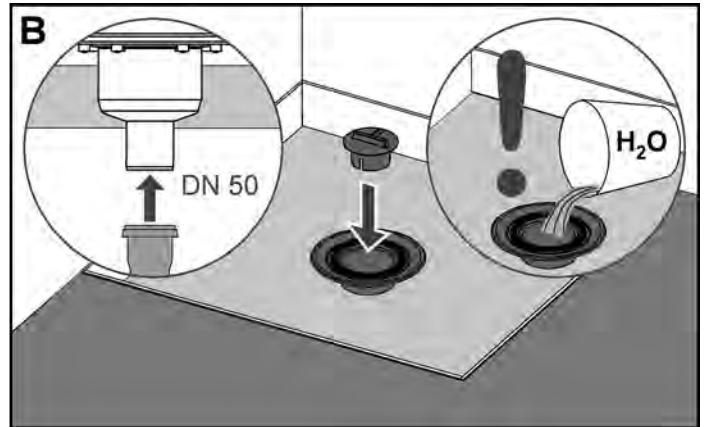

Connect the drain socket from the floor drain to the HT pipe at the intended drain connection point. Carry out tightness test: Fill water in the drain and carry out a visual inspection.

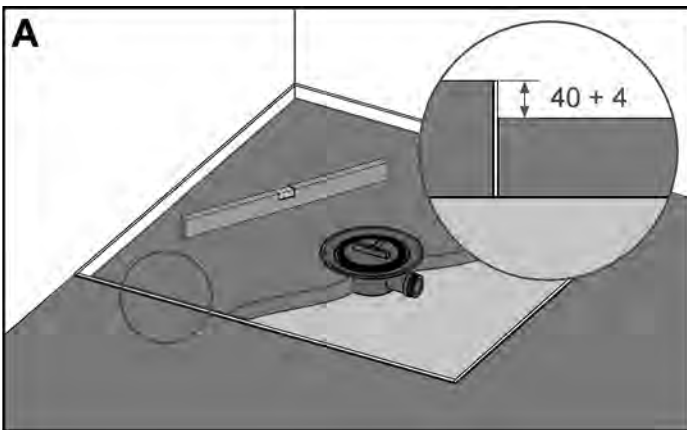

Lay screed, distance to screed height in adjacent area: 40 mm + height of tile adhesive (here 4 mm).

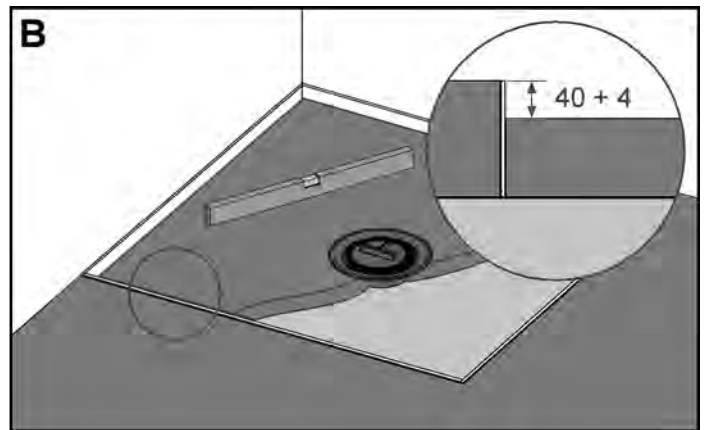

Lay screed.

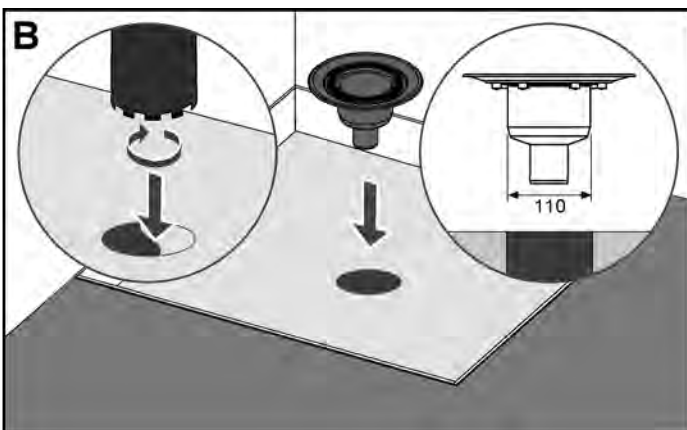

For vertical drains, a 110 drill hole is required.

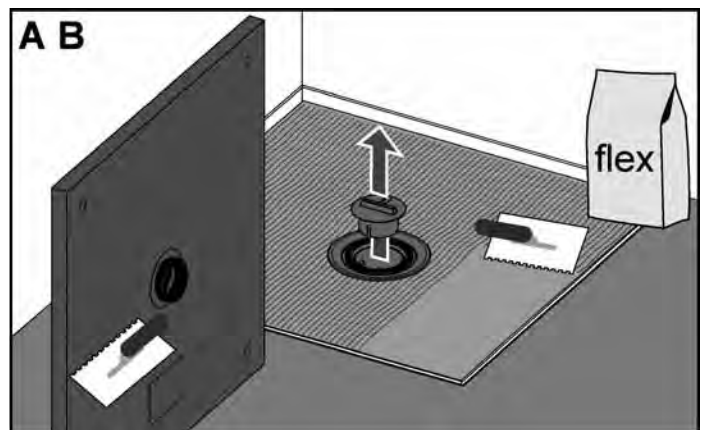

Coat the screed and Drainboard underside with flexible adhesive. Remove the protective cover and press the Drainboard onto the screed.

TECEdrainboard – assembly instructions

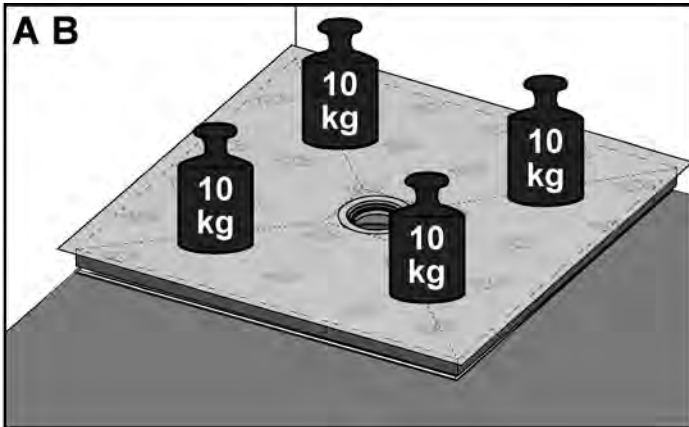

Press down the shower board with weights on all sides.

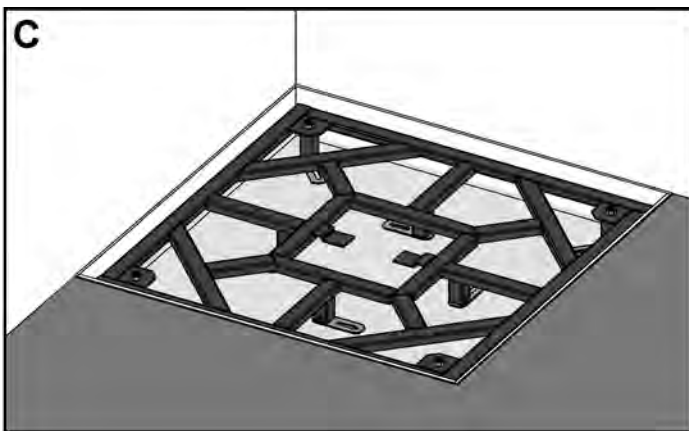
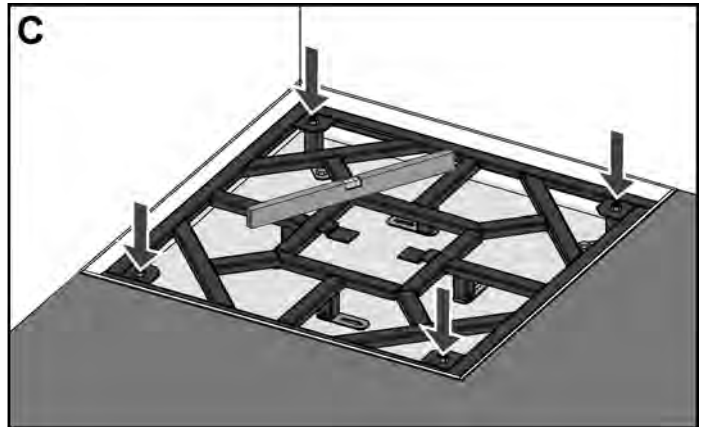

If the easy-to-use sub-structure framework is used – instead of a compensating screed – the sub-structure framework is first mounted horizontally on the concrete floor.

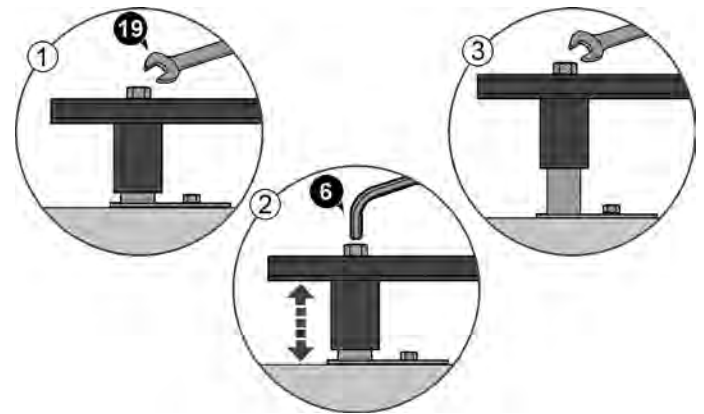

Taking account of the height of the shower element (40 mm), an allen wrench is used to adjust the four outer levelling feet of the sub-structure framework to the screed covering height using the set screws accessible from above.

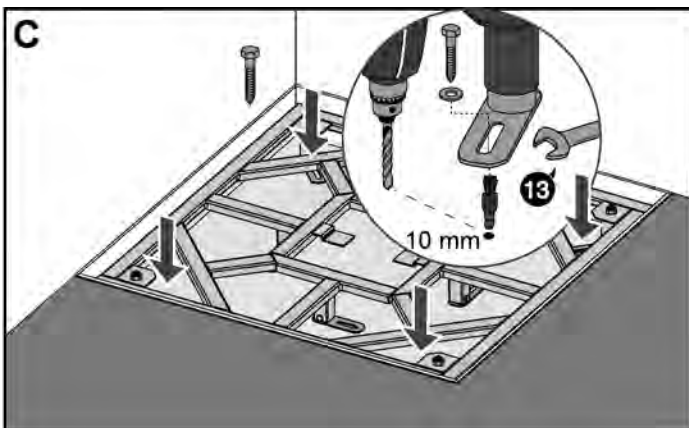

After horizontal alignment to the screed bordering the wall, the feet can be screwed to the concrete floor.

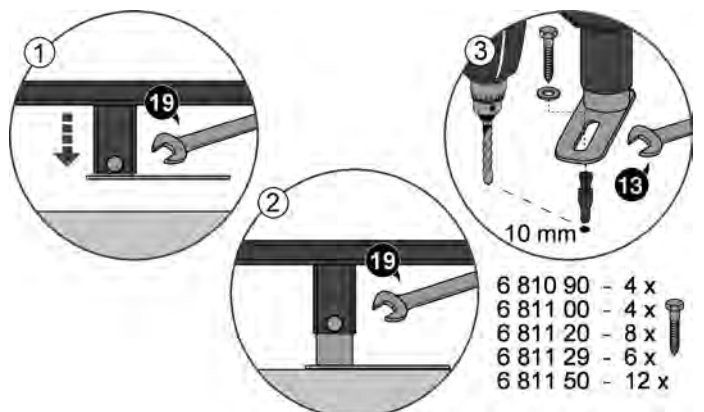
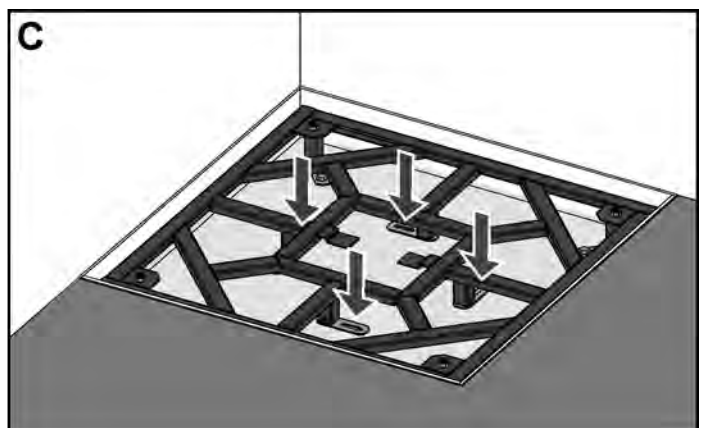

- 6 810 90 - 4 x
- 6 811 00 - 4 x
- 6 811 20 - 8 x
- 6 811 29 - 6 x
- 6 811 50 - 12 x

Following alignment, the middle feet are simply let down to the concrete floor and fixed with a side screw. The feet can then be screwed to the concrete floor. Depending on the size of the shower element, you need between 4 and 12 screws.

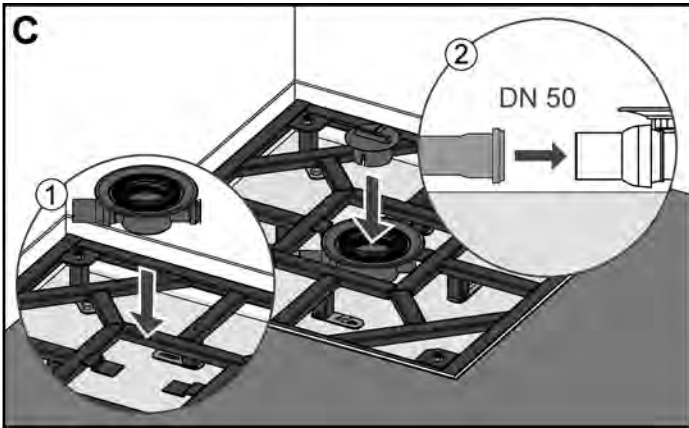

The horizontal floor drain is then simply laid on the centrally positioned fixing unit and can be screwed onto the shower element from above at a later stage. Connect the drain socket from the floor drain to the HT pipe at the intended drain connection point.

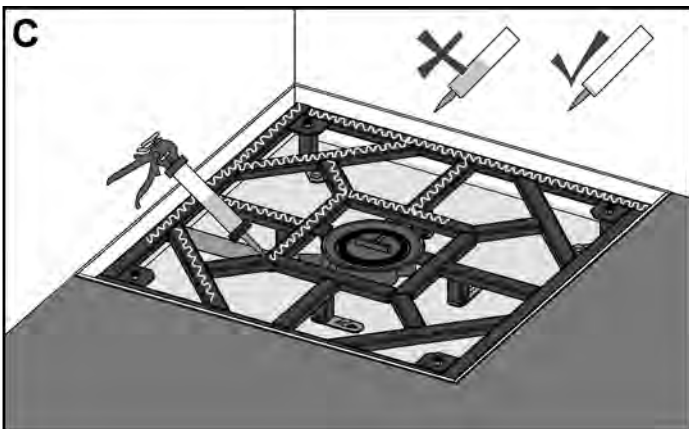

Apply the supplied assembly adhesive evenly on the surface of the sub-structure framework.

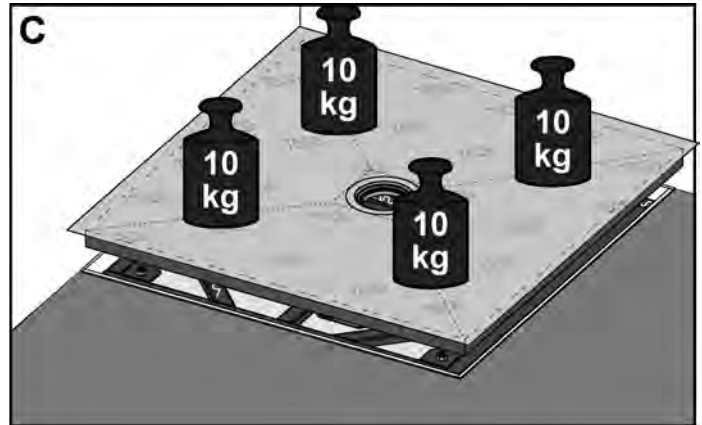

The shower element (sealing foil facing up) can then be glued directly onto the sub-structure framework. Press down the shower element with weights on all sides.

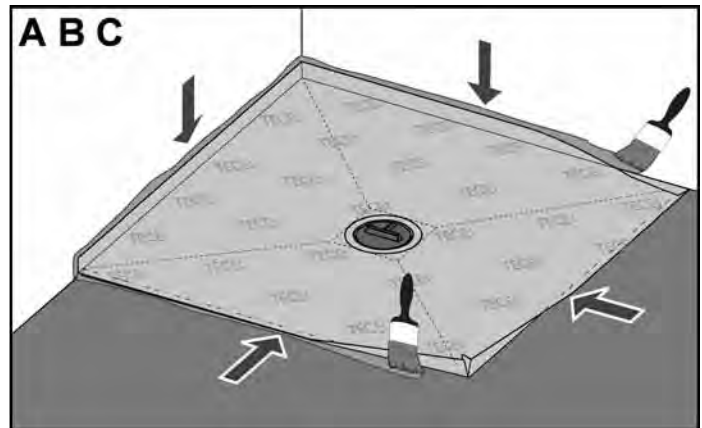

For ideal sealing, cut in the sealing fleece at the corners. Apply the overlap of the board to the wall or floor with a damp-proof coating.

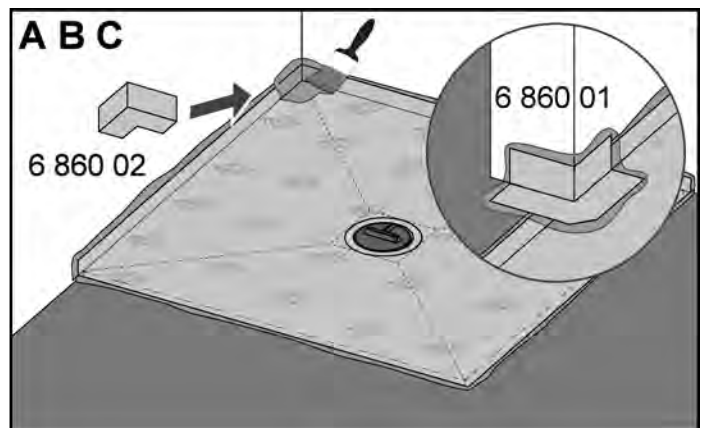

Attach the water-impermeable internal or external sealing angle.

TECEdrainboard – assembly instructions

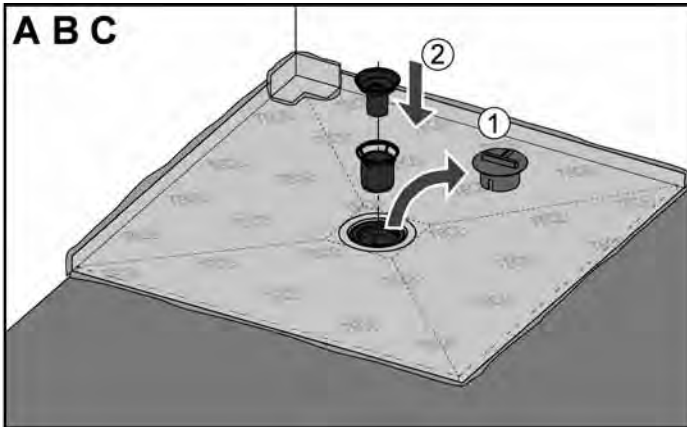

Remove the protective cover and insert the immersion pipe with the odour trap beaker.

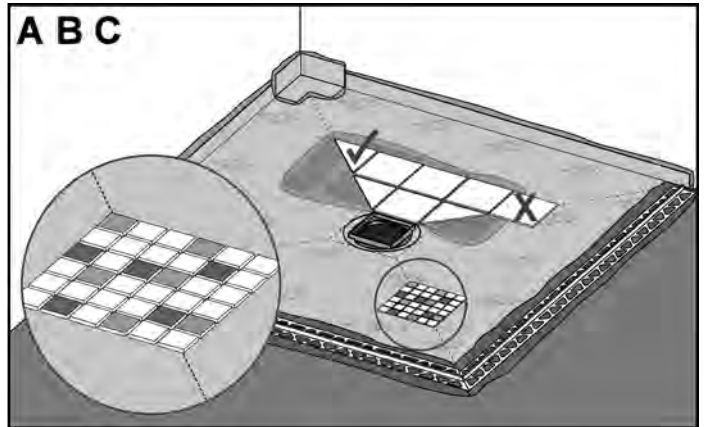

Apply tile adhesive and glue tiles.

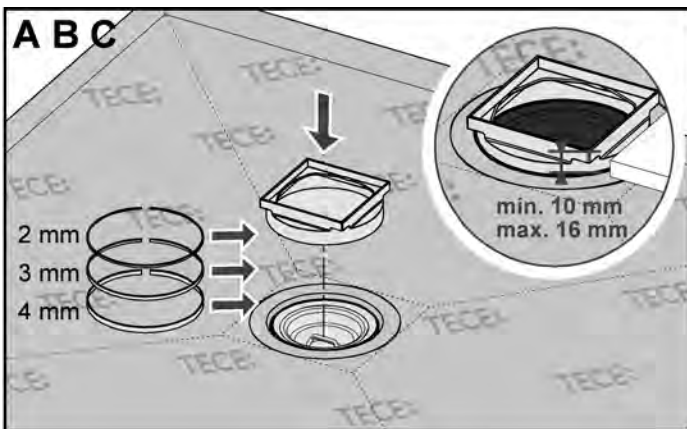

If necessary, the height-adjustable compensating rings can be used for the flexible adjustment of the drain grate to the top edge of the finished floor.

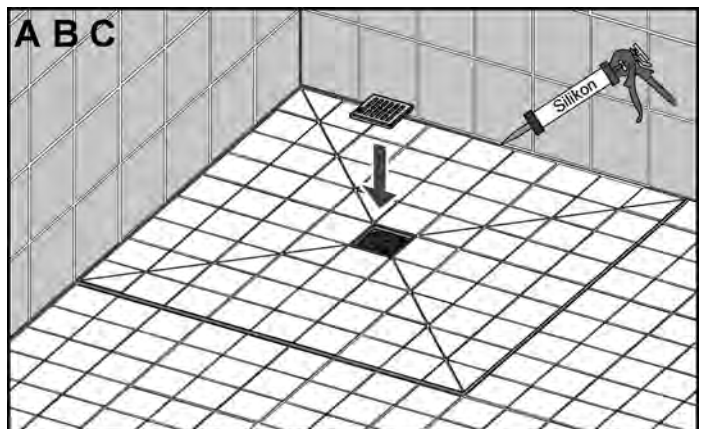

Coat grate frame with silicone and include expansion joints.

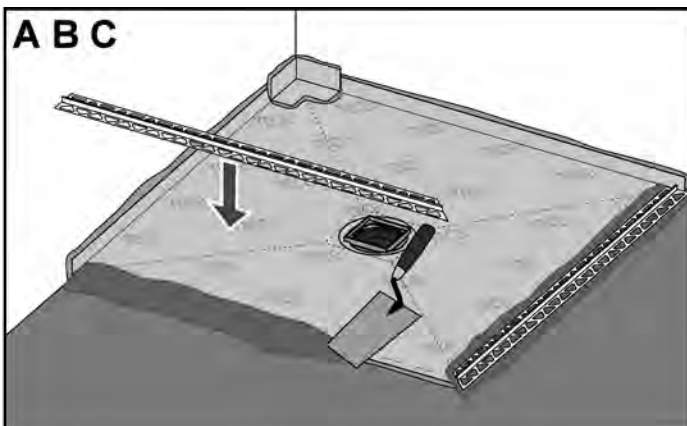

Include expansion rail if required, otherwise take account of expansion joint.

**Installation suggestion for flush-level
TECEDrainboard shower element**

TECEDrainboard on compensating screed with Drainbase sound-proofing mat for installation heights of 130 mm or higher.

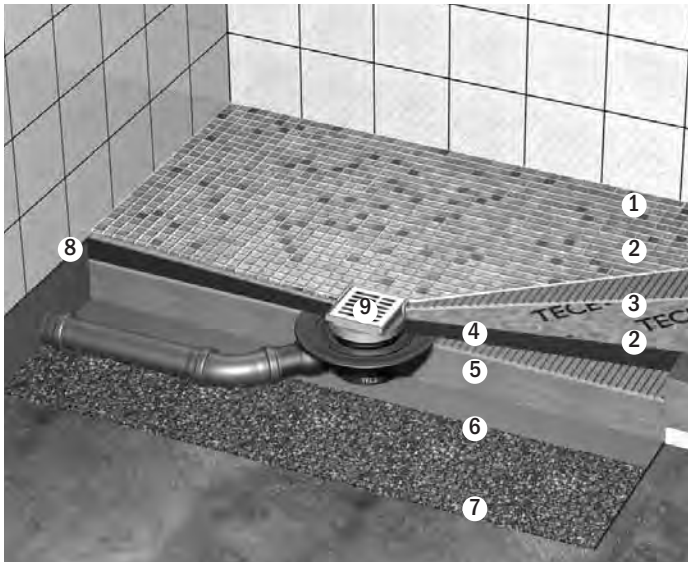

- | | | |
|------------------|-----------------------|-------------------------|
| 1 Tiles | 4 Compensating screed | 7 Bare floor |
| 2 Tile adhesive | 5 PE foil | 8 Edge insulation strip |
| 3 Shower element | 6 Drainbase (6 mm) | 9 Floor drain |

Installation example:

TECEDrainboard (1000 mm x 1000 mm) with floor drain, drain socket DN 50, horizontal

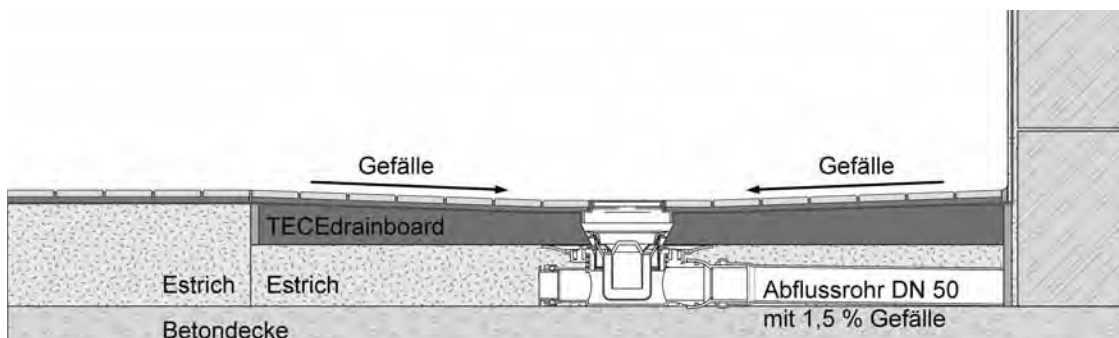

Minimum installation height: 118 mm (without drain pipe)
 Minimum installation height: 130 mm (including drain pipe with 1.5 % incline)

Planning

Accessible (barrier-free) bathroom design

Demographic change is increasing the demand for barrier-free homes. Disability, accident or old age – there are numerous reasons why people become restricted in their movements, or need to use a wheelchair. For them, it is important that not only public buildings but also - in particular - their own homes are designed so that they can move around freely. "Accessibility" and "barrier-free" are the terms used to describe this in the industry. Sufficiently wide doors, no door steps, no stairs, and a flush-level shower in the bathroom are the requirements for achieving this. TECEdrainboard makes a life without barriers possible in the shower area. The flush-level tiled shower makes access to the shower area easier.

DIN 18025-2 specifies the requirements for an accessible bathroom.

- Areas for manoeuvre of 1.20 m x 1.20 m in front of the toilet, washstand and shower
- In all cases, the shower must provide access without steps for entry with or without a wheelchair. To ensure turning is possible, an area of manoeuvre of at least 1.50 m x 1.50 m must be available.
- The floor drain must be planned with a distance of at least 0.30 m from one corner.
- The distance between the front edge of the shower and other fixtures or walls must be at least 0.90 m according to DIN 18025-2.
- The floor must be firmly laid, have level access and be non-slip.

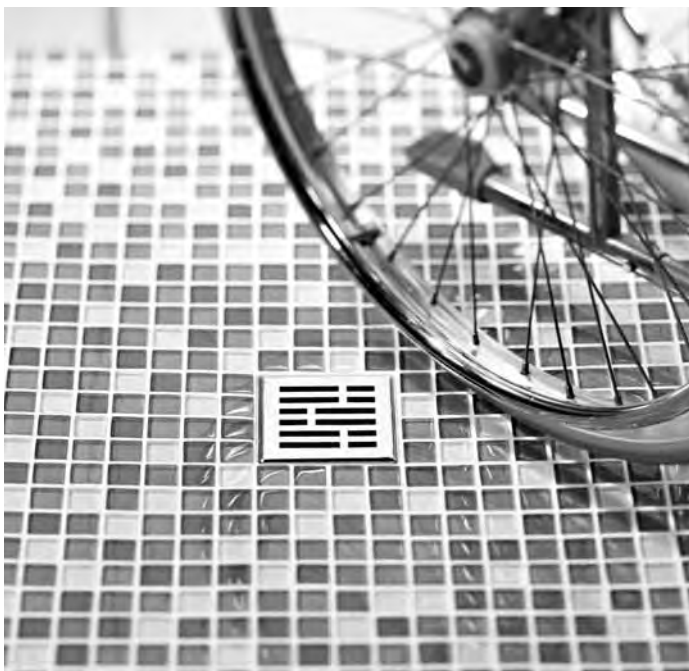

Fire protection

Installation requirements for fire resistant floor drain in accordance with general construction-supervisory test by MPA NRW, Erwitte department.

The fire resistant floor drain TECEdrainboard Firestop has the required proof of suitability in the form of the general building supervisory test certificate (AbP): P-MPA-E-04-010 from MPA NRW. This test certificated can be provided by TECE on request. The installation requirements of the test certificate must in all circumstances be complied with.

Installation requirements:

Base body height (without drain socket):	110 mm
Solid floor thickness:	150 mm
Required minimum concrete substructure (B):	≥ 40 mm

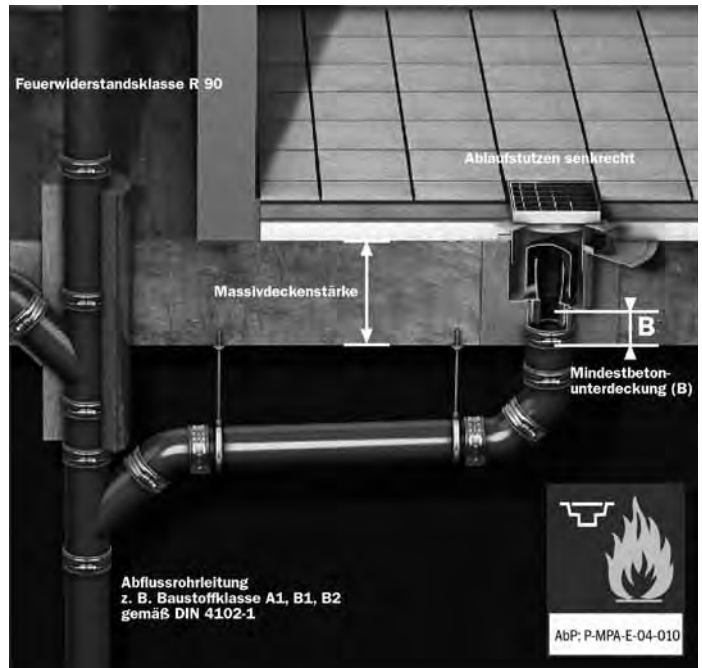

Installation suggestion for flush-level TECEdrainboard shower element with fire resistant floor drain

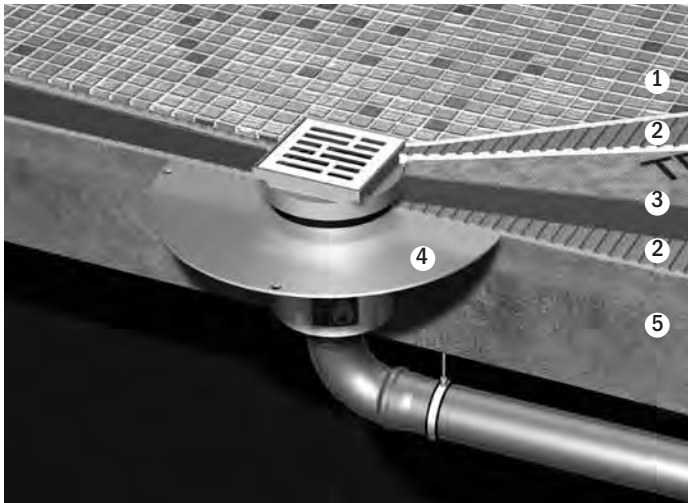

- 1. Tiles/mosaic
- 2. Tile adhesive
- 3. Shower element TECEdrainboard including water-impermeable sealing foil
- 4. Fire resistant floor drain TECEdrainboard FireStop
- 5. Compensating screed

Sound insulation

The TECE product range contains the compression-resistant sound-proofing mat "Drainbase". The mat, which is just 6 mm thick, is laid in the entire shower area between the bare floor and the screed. The material, manufactured in a resource-efficient way using recycled rubber, provides particularly effective sound insulation: This sound-proofing mat meets the requirements of DIN 4109 and can be used for both TECEdrainline and TECEdrainboard.

According to DIN 4109, the requirements relating to the noise level for living rooms and bedrooms caused by water installations is ≤ 30 dB(A). In connection with Drainbase, a noise level of 23 dB(A) can be achieved. This value is confirmed by an official noise level assessment.

In contrast to conventional sound insulation made of soft polystyrene, the TECE sound-proofing mat does not give under pressure. Even under pressure of 15 t/m², the compression is just 0.6 mm. This prevents the silicon joint between the floor and wall covering from tearing off.



Drainbase sound-proofing mat

Standards

DIN 1986: Drainage systems for buildings and land

- Part 3: Rules for operation and maintenance (2004)
- Part 4: Application areas for waste water pipes and mouldings made of various materials (2011)
- Part 30: Maintenance (2012)

DIN 1986-100: Drainage systems for buildings and land/
provisions in connection with DIN EN 752 and
DIN EN 12056 (2008)

DIN 18024 parts 1 and 2: Barrier-free building/publicly
accessible buildings and work places/basis for planning
(1996–1998)

DIN 18040 part 2: Barrier-free building - basis for planning -
residential buildings (2011)

DIN 18195 parts 1 to 10: Building waterproofing
(2009–2011)

DIN EN 12056, DIN 1986 and DIN EN 1610 comment:
Building and land drainage (2000)

DIN EN 1253, parts 1 to 3: Drains for buildings
(1999–2003)

DIN 4109 (1989): Sound insulation in buildings,
requirements and verification, amendment A1 (2001)

VDI 4100: Sound insulation in residential buildings –
criteria for planning and evaluation (2007)

Model building regulation (MBO) (2002)

ZDB (German Construction Confederation) information
sheet: Bonded damp-proofing – information for designing
liquid bonded damp-proofing with cladding and coverings of
tiles and slabs for indoor and outdoor areas (2010)

GIPS information sheet 5: Bathrooms and damp rooms in
timber construction and dry-wall construction (2006)



For more information on our products,
please visit us at www.tece.com.

TECE GmbH
Hollefeldstraße 57
D-48282 Emsdetten
Germany
international-business@tece.de
www.tece.com

TECE ■
Intelligente Haustechnik